

# MultiFlex I/O Board

## Installation and Operation User Manual

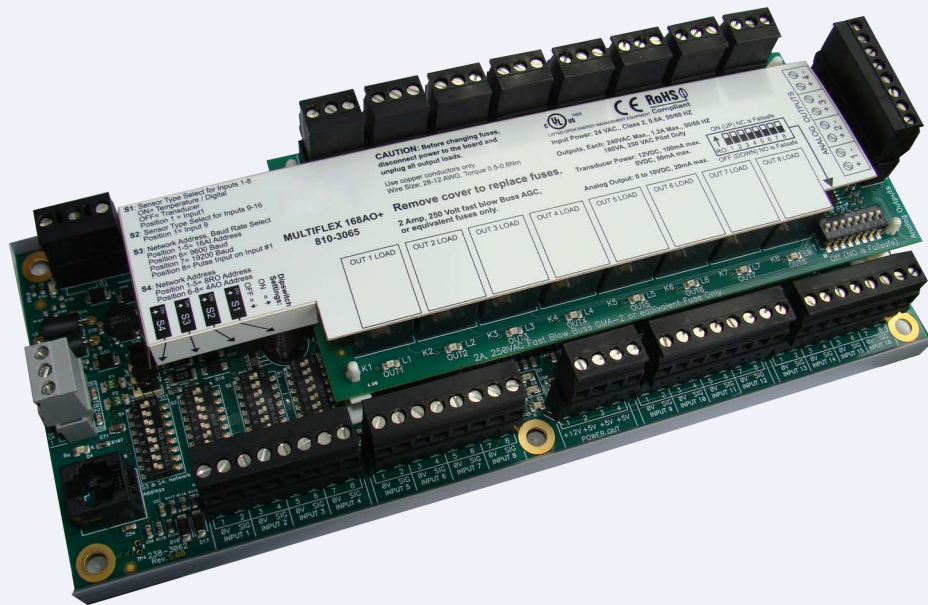

Copeland  
1065 Big Shanty Road NW, Suite 100  
Kennesaw, GA 30144 USA  
770-425-2724 • 1-800-829-2724  
[www.copeland.com](http://www.copeland.com)  
Email: [ColdChain.TechnicalServices@copeland.com](mailto:ColdChain.TechnicalServices@copeland.com)

## READ ALL INSTRUCTIONS CAREFULLY

If the equipment is not used in the manner specified by the manufacturer, the protection provided by the equipment may be impaired.

## SAVE THIS INSTRUCTION MANUAL

This instruction manual contains important operating instructions for the MultiFlex family of I/O boards, including the MultiFlex 16 input boards, and the MultiFlex 88, 88AO, 168, 168AO, and 168DO, 1616AO and 1616DO combination input/output boards.

## FCC COMPLIANCE NOTICE

This device complies with Part 15 of the FCC Rules. Operation is subject to the following two conditions: (1) this device may not cause harmful interference, and (2) this device must accept any interference received, including interference that may cause undesired operation.



**1 OVERVIEW OF THE MULTIFLEX PRODUCT LINE ..... 1**

1.1 MultiFlex 16 Input Board.....1

1.2 MultiFlex Combination Input/Output Boards .....1

1.3 Other Boards in the MultiFlex Family.....3

    1.3.1 The MultiFlex RTU.....3

    1.3.2 The MultiFlex RCB.....3

    1.3.3 The MultiFlex CUB-II and CUB-TD.....3

    1.3.4 The MultiFlex PAK .....3

**2 MOUNTING AND POWERING ..... 4**

2.1 Snap-Track Installation.....4

2.2 The Plug-In Output Board.....4

2.3 Powering the MultiFlex.....5

    2.3.1 Choosing Transformer Sizes .....5

    2.3.2 MultiFlex 16 Power Wiring.....5

    2.3.3 MultiFlex Combination Input/Output Board Power Wiring .....6

        2.3.3.1 New-Style MultiFlex Combination I/O Boards (with Isolated Power Supply).....6

        2.3.3.2 Old-Style MultiFlex Combination I/O Boards (No Isolated Power Supply) .....7

    2.3.4 Wire Types and Maximum Distances.....7

**3 THE I/O NETWORK..... 8**

3.1 Wire Types.....8

3.2 Network Configuration  
(Daisy Chains).....8

    3.2.1 Maximum # of Boards on a Daisy Chain .....8

3.3 Network ID Numbers.....8

    3.3.1 Numbering the MultiFlex 16.....9

    3.3.2 Numbering for MultiFlex Combination I/O Boards .....9

    3.3.3 Addressing the 168DO.....10

3.4 Setting the Baud Rate .....10

3.5 Setting the Terminating  
Resistance Jumpers.....10

**4 I/O BOARD INPUT AND OUTPUT SETUP ..... 11**

4.1 The Inputs.....11

    4.1.1 Connecting Sensors to Input Boards.....11

        4.1.1.1 Wiring.....11

        4.1.1.2 Input Wiring When Replacing 16AI or CIO/8IO Boards With MultiFlex .....11

        4.1.1.3 Sensor Wiring Types.....12

        4.1.1.4 Input Type Dip Switches.....12

        4.1.1.5 Pulse Type Inputs .....12

    4.1.2 Power Connection .....12

        4.1.2.1 Current Ratings for On-Board Power Sources .....12

        4.1.2.2 Powering Sensors Requiring 24VAC Off the Power Transformer .....13

    4.1.3 Sensor Types for MultiFlex Input Points .....13

4.2 The Relay Outputs.....13

    4.2.1 Output Fail-Safe Dip Switches .....13

    4.2.2 Relay Output Ratings and Fuse Protection.....13

4.3 The Analog Outputs .....14

4.4 The Digital Outputs.....14

**5 BOARD STATUS LEDs ..... 15**

5.1 Status LED..... 15

5.2 Tx and Rx LEDs..... 15

5.3 Code A and Code B LEDs..... 15

5.4 Relay Output LEDs ..... 15

**6 THE MULTIFLEX HAND-HELD TERMINAL INTERFACE ..... 16**

6.1 MultiFlex I/O Board Hand-Held Terminal Screens..... 16

6.1.1 Navigation ..... 16

6.1.2 Opening Screen ..... 17

6.1.3 Board Address..... 17

6.1.4 Settings..... 18

6.1.5 Input/Output Select Menu..... 18

6.1.6 Input Screens ..... 18

6.1.6.1 Input Status/Config Menu ..... 18

6.1.6.2 Status-Volts..... 18

6.1.6.3 Status-Eng Units ..... 18

6.1.6.4 Input Config ..... 19

6.1.7 Relay Output Screens..... 20

6.1.8 Analog Output Screens ..... 21

6.1.8.1 Analog Status/Override..... 21

6.1.9 Analog Fail-Safes..... 21

6.1.10 Digital Status (PWM) ..... 21

6.1.11 Digital Period Status..... 22

6.1.12 Config Fail % Screen ..... 22

**7 RELAY OUTPUT TEST MODE ..... 23**

# 1 Overview of the MultiFlex Product Line

The MultiFlex line of control system boards provide a wide variety of input, output, and smart control solutions, all of which are based on a single universal hardware platform. The board design uses flash-uploadable firmware and plug-in expansion boards to configure the base platform board and apply it for use as an input board, relay output board, analog output board, or a combination I/O board.

## 1.1 MultiFlex 16 Input Board

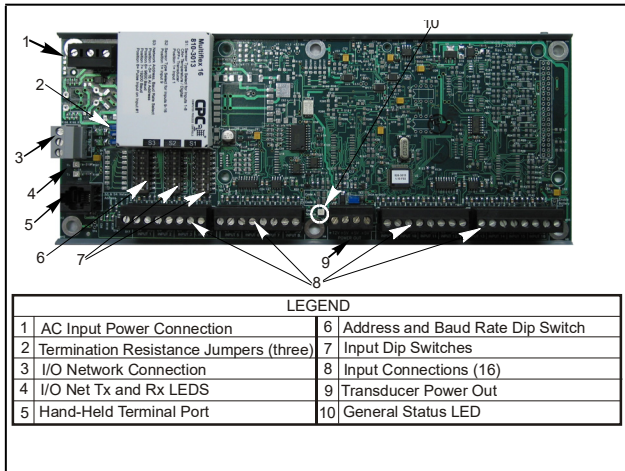

Figure 1-1 - MultiFlex 16 Input Board

The MultiFlex 16 input board offers sixteen combination analog/digital input points for use by Copeland Einstein and REFLECTS control systems. The MultiFlex 16 is designed to be 100% compatible with the previous generation of Copeland input boards (the 16AI), and may be used in retrofits with no additional hardware or software setup or upgrades.

Like the 16AI, the MultiFlex 16 communicates with the site controller via an RS485 connection to a REFLECTS COM A&D network or an Einstein I/O network. Dip switches on the board set the network ID (board number) and baud rate.

The board also provides both +5VDC and +12VDC output voltage points for use in powering transducers or other input devices that require power.

Unlike the 16AI, the MultiFlex 16 has a hand-held terminal interface, which may be used by technicians to view the input voltage and engineering unit values for each input point without need of a voltmeter or front panel controller display.

Table 1-1 shows the part number of the MultiFlex 16.

Table 1-1 - MultiFlex 16 and 8 Input Board Models

P/N	Model Name	Description
810-3013	MultiFlex 16	16 analog/digital inputs, no outputs

## 1.2 MultiFlex Combination Input/Output Boards

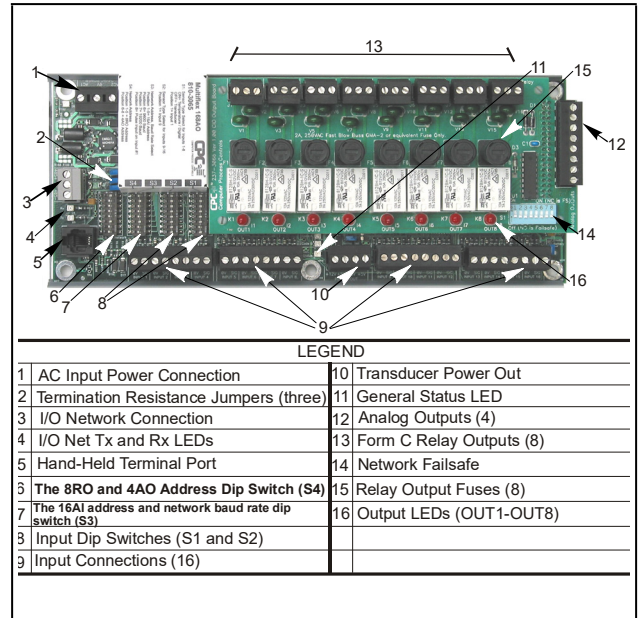

Figure 1-2 - MultiFlex 16AO Combination Input/Output Board

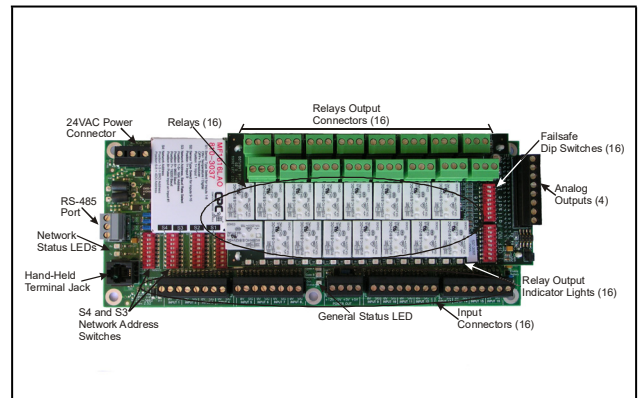

Figure 1-3 - MultiFlex 1616 Combination Input/Output Board

There are several models of the MultiFlex board that combine the functionalities of input boards, relay output boards, digital output boards, and analog output boards. The MultiFlex combination input/output boards are designed to be replacements for the 8IO Combination Input/Output Board, but the MultiFlex board provides several new hardware options and software features.

The MultiFlex combination I/O boards consist of two circuit boards: a bottom layer with up to 16 combination digital/analog inputs, and a plug-in top layer which contains a combination of relay outputs, digital outputs, and analog outputs.

All boards feature both +5VDC and +12VDC output voltage points for use in powering transducers or other input devices that require power.

On the RS485 Network, the MultiFlex combination input/output boards present themselves to the Einstein or REFLECS site controller as 16AI Analog Input Boards, 8RO Relay Output Boards, 8DO Digital Output Boards, and/or 4AO Analog Output Boards, depending on what type of inputs or outputs are equipped. Dip switches are used to assign network ID numbers to each board type.

The MultiFlex combination input/output boards also support a hand-held terminal interface, which allows technicians to view input values, check output states, and override output points with fixed digital or analog values.

**Table 1-2** shows the available models of MultiFlex combination input/output boards.

**Table 1-2 - MultiFlex Combination Input/Output Board Models**

P/N	Model Name	Description
810-3063	MultiFlex 88AO	8 analog/digital inputs, 8 relay outputs, 4 analog outputs, no battery
810-3064	MultiFlex 88	8 analog/digital inputs, 8 relay outputs, no battery
810-3065	MultiFlex 168AO	16 analog/digital inputs, 8 relay outputs, 4 analog outputs, no battery
810-3066	MultiFlex 168	16 analog/digital inputs, 8 relay outputs, no battery
810-3067	MultiFlex 168DO	16 analog/digital inputs, 8 relay outputs, and 4 pulse-width modulating digital output. No battery.
810-3073	MultiFlex 1616LAO	16 analog/digital inputs, 16 low-voltage (24VAC rated) relay outputs, and 4 analog outputs. No battery.
810-3077	MultiFlex 1616LDO	16 analog/digital inputs, 16 low-voltage (24VAC rated) relay outputs, and 4 pulse-width modulating digital outputs. No battery.
810-3072	MultiFlex 1616L	16 analog/digital inputs, 16 low-voltage (24VAC rated) relay outputs. No battery.

## 1.3 Other Boards in the MultiFlex Family

In addition to the I/O boards described above, the MultiFlex hardware is used as the base for a number of “smart” boards capable of controlling refrigeration and HVAC systems or subsystems independently from a central site controller. These boards, which are considered “controllers” in their own right, has the battery and are therefore covered in separate manuals. For informational purposes, these boards are described below.

### 1.3.1 The MultiFlex RTU

Similar in design to the MultiFlex combination input/output boards, the MultiFlex RTU board is designed specifically for operating package rooftop HVAC units as part of an Einstein BX or REFLECS BCU building control system. The MultiFlex RTU is designed to be a replacement for the previous generation ARTC, and is 100% compatible with all legacy Einstein BX and BCU systems.

The MultiFlex RTU board has 16 analog inputs, 8 relay outputs and 4 analog outputs. Most of these I/O points are reserved for sensors and input devices required to read environmental data (such as space and supply air temperature) and control all output devices that control the environment (such as heat/cool stages and dampers). The RTU relay outputs are rated for line voltage (240VAC).

The RTU board controls the rooftop unit directly with its built-in heating, cooling, and humidity control algorithms. It may operate in stand-alone mode, or it may interface with an Einstein BX or BCU to control the store environment in zones and pass along logging and alarm information.

The MultiFlex RTU has its own installation and operation manual, *P/N 026-1706*.

### 1.3.2 The MultiFlex RCB

The RCB is an improved version of the MultiFlex RTU. The RCB has sixteen fully configurable analog and digital input points, whereas the RTU has only eight inputs, two of which are configurable. The RCB has four analog outputs for use in controlling variable speed fans, economizers or modulating heating and/or cooling valves, whereas the RTU has only two analog outputs for use only with VS fans and economizers. The RCB also features a more sophisticated HHT interface and updated algorithms for controlling heating, cooling, dehumidification, and air quality. The MultiFlex RCB has its own installation and operation manual, *P/N 026-1707*.

### 1.3.3 The MultiFlex CUB-II and CUB-TD

The MultiFlex Condensing Unit Board (CUB) is a “smart” input/output board designed to control single condensing units. The MultiFlex CUB-II controls all aspects of a condensing unit, including compressor control, and condenser fan control. The MultiFlex CUB-TD is a scaled-down version of the CUB-II that controls condenser fans using a temperature differential strategy.

The MultiFlex CUB uses the same general hardware configuration as a MultiFlex 168AO. It is equipped with a processor and extra memory to allow it to control compressors, condensers, refrigeration, and defrost for a single condensing unit using on-board I/O and control algorithms.

The MultiFlex CUB has its own installation and operation manual, *P/N 026-1705*.

### 1.3.4 The MultiFlex PAK

The PAK is a distributed pack (rack) controller that controls compressors and condenser fans. The PAK can control up to 8 compressor groups containing up to 16 compressors. The compressor control strategy is either Fixed Steps with up to 20 fixed combinations of compressor groups, or an alternate Cyclic strategy that distributes compressor activations, with setpoint/deadband using ON and OFF delays.

The PAK can also control up to 4 condenser fan groups containing up to 8 total condenser fans. The PAK condenser control strategy is sequential TD control with setpoint/deadband using ON and OFF delays.

The MultiFlex PAK has its own installation and operation manual, *P/N 026-1722*.

## 2 Mounting and Powering

The MultiFlex boards are usually installed by the refrigeration or building equipment manufacturer. Therefore, the installer need only make the necessary connections between the boards and the site controller(s).

In some instances, an installer may be required to mount an I/O board. There are no restrictions on the location of these boards; however, for ease of network configuration, it is recommended that the boards be located adjacent to the Einstein. I/O boards may be mounted without an enclosure, but they should be mounted in a location that is not easily accessible to avoid tampering or damage.

### 2.1 Snap-Track Installation

MultiFlex boards not supplied in a custom panel or other enclosure are supplied with a snap-track for easy installation. The insulation sheet and I/O board must be removed from the track before the track is mounted. The snap-track is mounted using the 0.1875" mounting slots. **Figure 2-1** shows this installation procedure.

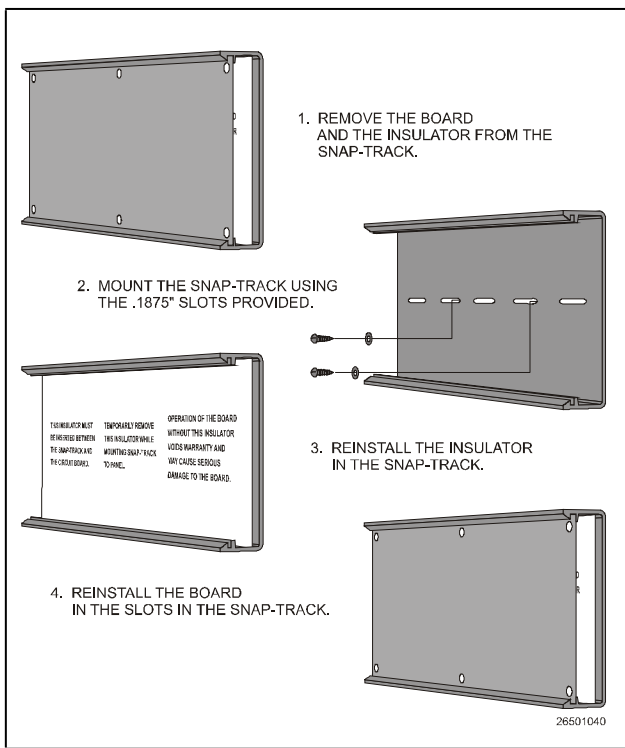

Figure 2-1 - MultiFlex Snap-Track Mounting

**Figure 2-2** provides mounting dimensions for the MultiFlex board.

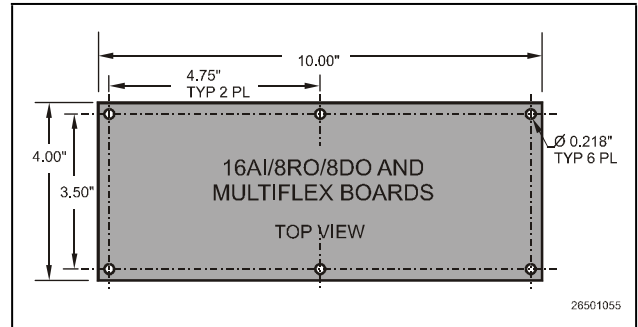

Figure 2-2 - MultiFlex Board Dimensions

### 2.2 The Plug-In Output Board

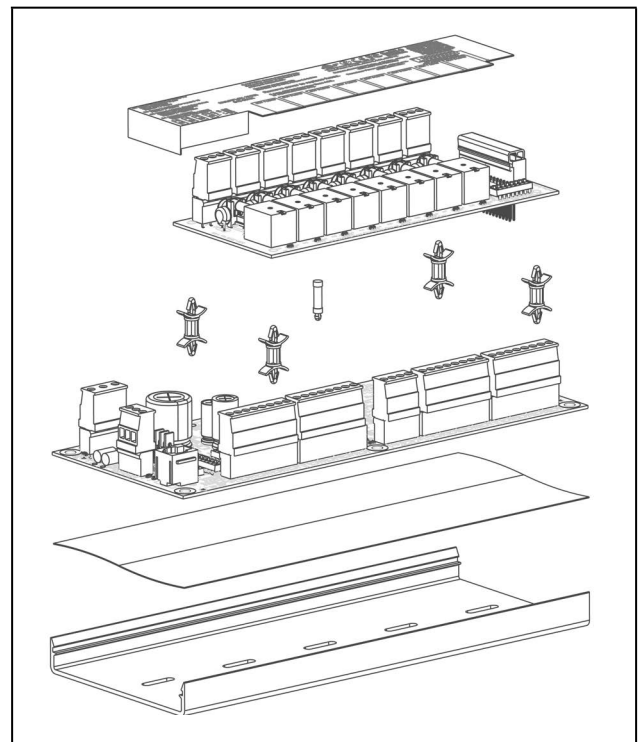

Figure 2-3 - Exploded View -- MultiFlex Combination I/O Board



All MultiFlex boards except the MultiFlex 16 have output sub-boards that plug in to the top of the base board. These boards are shipped with the output board pre-installed on the board using stand-offs, so no additional hardware setup should be necessary.

The additional board makes the MultiFlex combination I/O boards considerably taller than the MultiFlex 16 and all previous-generation Copeland I/O boards. If you will be mounting these boards in an enclosure, the board will need at least 2.5" of clearance between the base board and the panel door.

## 2.3 Powering the MultiFlex

All models of MultiFlex require a 24VAC Class 2 input power source. The MultiFlex 16 requires the power source to be **center-tapped**. All other models do not use the center tap.

Copeland supplies a wide variety of 24VAC transformers with varying sizes and either with or without center taps. **Table 2-1** shows the transformer sizes and whether they are center-tapped or non-center-tapped.

**Table 2-1 - Transformers Compatible with MultiFlex Board**

Xformer P/N	VA Rating	Primary Voltage	Center Tap?
640-0041	50 VA	110 VAC	No
640-0042	50 VA	220 VAC	No
640-0056	56 VA	Multi-tap (120/208/240 VAC)	Yes
640-0050	75 VA	110 VAC	No
640-0045	75 VA	220 VAC	No
640-0080	80 VA	Multi-tap (120/208/240 VAC)	Yes

### 2.3.1 Choosing Transformer Sizes

In most site installations, a single transformer will power multiple devices. Choose a transformer with a VA rating large enough to power all devices that will be attached to it. **Table 2-2** gives the VA ratings of the MultiFlex board products. Refer to your site controller’s manual for VA ratings of the other I/O boards that may be powered by one of these transformers

**Table 2-2 - Device Power Requirements**

Unit	VA	VAC	Center tapped?
MultiFlex 16	6	24	Yes
MultiFlex 88, 88AO, 168, 168AO and 168DO	15	24	NO

### 2.3.2 MultiFlex 16 Power Wiring

The MultiFlex 16 requires connection to a transformer with a center tap such as the 56VA (640-0056) and 80VA (640-0080) transformers listed in **Table 2-1**. The 56VA and 80VA transformers have quick-connects on the primary and secondary sides for connection to line voltage and the MultiFlex 16 board. **Figure 2-4** shows how to make those connections. Note the center tap connection on the secondary side (CT) must be wired to the 0V terminal on the MultiFlex 16.

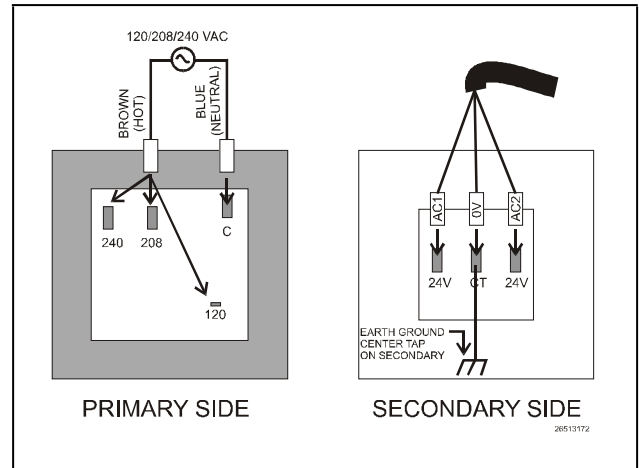

*Figure 2-4 - 640-0056 and 640-0080 Transformer Wiring*

### 2.3.3 MultiFlex Combination Input/Output Board Power Wiring

The MultiFlex 88, 88AO, 168, 168AO, and 168DO boards do not use a center tap. Instead, the 0V terminal on the board should be connected to a separate Earth ground.

**Important! The rules that must be followed when connecting a MultiFlex Combination I/O board to a transformer are different depending on whether you have a “new style” MultiFlex board with an isolated power supply (all MultiFlex boards shipped after November 1, 2002) or an “old style” MultiFlex board (all MultiFlex boards shipped before November 1, 2002).**

A new-style MultiFlex Combination I/O board has a green power LED located next to the 24VAC connection terminal in the upper right corner of the circuit board (see **Figure 2-5** for reference).

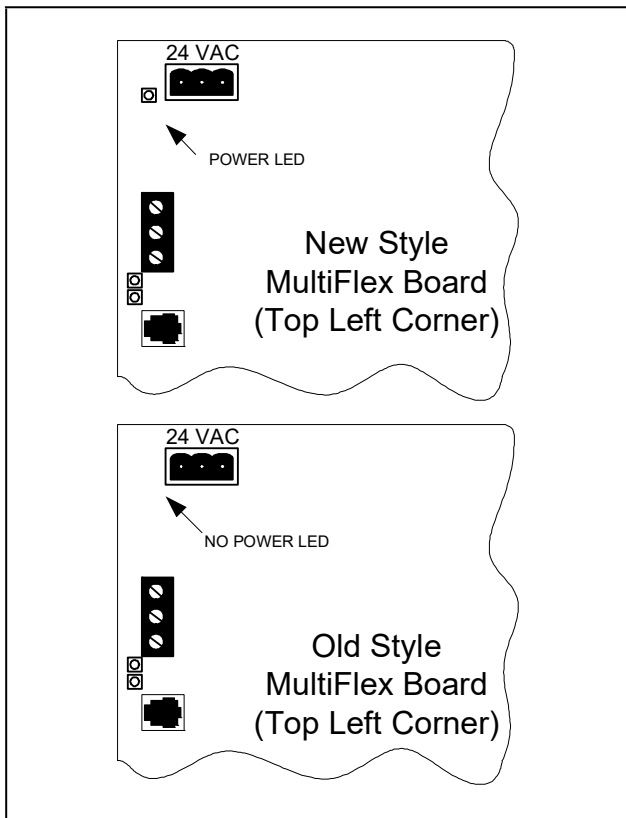

Figure 2-5 - New-Style vs. Old-Style MultiFlex Board

If there is a power LED next to the connector, your MultiFlex is a **new-style MultiFlex** -- refer to **Section 2.3.3.1, New-Style MultiFlex Combination I/O Boards (with Isolated Power Supply)** for power wiring instructions.

If there is no power LED next to the connector, your MultiFlex is an **old-style MultiFlex** -- refer to **Section 2.3.3.2, Old-Style MultiFlex Combination I/O Boards (No Isolated Power Supply)** for power wiring instructions.

#### 2.3.3.1 New-Style MultiFlex Combination I/O Boards (with Isolated Power Supply)

The new-style MultiFlex board can be connected to any of the center-tapped transformers mentioned in **Table 2-2**, provided the 0V terminal of the board is connected to an Earth ground.

A center-tapped transformer may power both center-tapped and non-center-tapped boards at the same time, as long as **none of the non-center-tapped MultiFlex boards are old-style MultiFlex boards**. If an old-style MultiFlex shares the same center-tapped transformer as a device that uses the center tap, boards on the network will be damaged.

**Figure 2-6** shows how to wire a non-center tapped device to a center-tapped transformer.

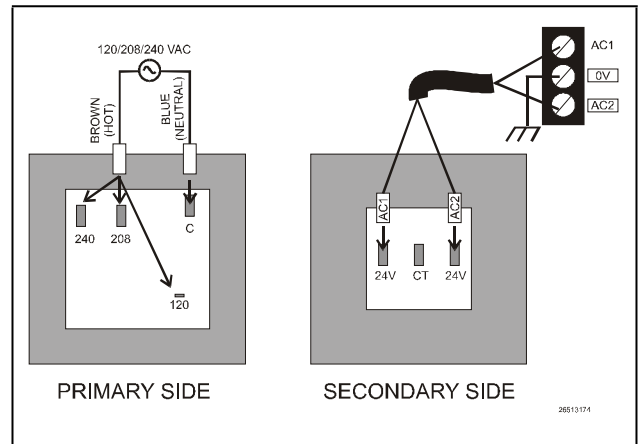

Figure 2-6 - Wiring Non-Center Tapped MultiFlex Boards to Transformers With a Center Tap

In addition, the MultiFlex combination boards can be powered by one of the 50VA or 75VA non-center-tapped transformers listed in **Table 2-1**. **Figure 2-7** shows how to wire the transformers to the MultiFlex boards.

You may also tie one side of the secondary (but not BOTH sides) or the center tap to an earth ground, provided none of the boards powered by the same transformer are old-style MultiFlex boards (see **Section 2.3.3.2, Old-Style MultiFlex Combination I/O Boards (No Isolated Power Supply)**).

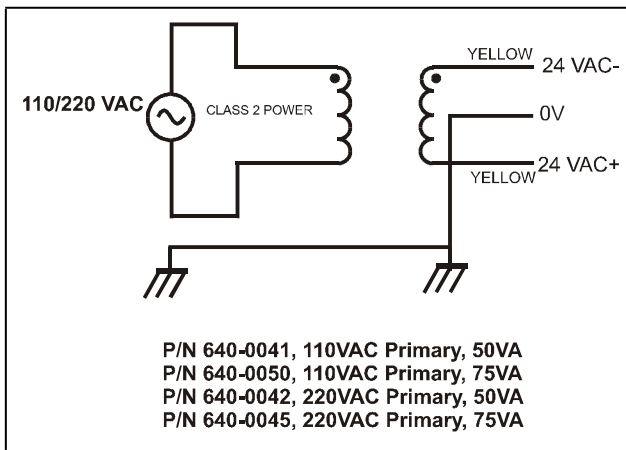

Figure 2-7 - Non-Center-Tapped Transformer Wiring

**NOTE** All wire connections to earth ground should be less than six (6) inches long and use a wire gauge of at least 14AWG.

### 2.3.3.2 Old-Style MultiFlex Combination I/O Boards (No Isolated Power Supply)

Like the new-style MultiFlex board, the old-style MultiFlex Combination I/O board can be connected to any of the center-tapped transformers mentioned in **Table 2-2**, provided you follow the following three rules:

**Rule 1: Ground the 0V terminal on the old-style MultiFlex board to an Earth ground.**

Do not connect the center tap of the transformer to the 0V terminal.

**Rule 2: Do not power an old-style MultiFlex non-center-tapped board with a transformer that is also powering a center-tapped device.**

This means you cannot connect an old-style MultiFlex non-center tapped board to a transformer that is powering a MultiFlex 16, 16AI, 8RO, 4AO, 8DO, a Gateway board, or any previous generation Copeland board that uses center-tapped power. Doing so will destroy the MultiFlex board.

**Rule 3: The secondary of the transformer must not be grounded on any side.**

Verify that neither side of the transformer secondary is connected to earth ground before powering the old-style MultiFlex board. A grounded secondary will damage the MultiFlex board.

In addition, the old-style MultiFlex combination boards can be powered by one of the 50VA or 75VA non-center-tapped transformers listed in **Table 2-1 on page -5**. **Figure 2-7** shows how to wire the transformers to the MultiFlex boards.

## 2.3.4 Wire Types and Maximum Distances

For powering I/O boards, use only the listed wire types from **Table 2-3**. Three-conductor non-shielded cables are the recommended wire for connecting between the center tapped transformer and the I/O boards. Shielded cable should not be used for power wiring. The center tap should be wired with the third conductor to earth ground at the transformer.

Each MultiFlex board should have its 0V terminal taken to a short, solid earth ground.

Table 2-3 - Power Wiring Types

Power Wiring Types	
14 AWG	Belden 9495 or equivalent
18 AWG	Belden 9493 or equivalent

The wire length from the transformer and the number of boards connected to the same wire determines the type wire gauge used. In most cases, the distance between the I/O boards and the transformer that supplies power to them is not enough to be concerned with. But it is very important not exceed this maximum wire length or the boards will malfunction.

Use these formulas to determine if the wire gauge you are using fits within specification:

<b>14 AWG:</b> Feet = $0.40 / (VA/24) \times 0.005$
<b>18 AWG:</b> Feet = $0.40 / (VA/24) \times 0.013$ (VA is the total VA rating of the I/O boards) For example, if you had an 80 VA load: 14 AWG: 24 ft. (rounded down) 18 AWG: 9 ft.

Figure 2-8 - Power Wire Lengths

### 3 The I/O Network

All MultiFlex boards and controllers use an RS485 network connection to communicate with Einstein and REFLECS site controllers. Technicians who are familiar with Copeland’s previous generation 16AI, 8IO, and ARTC boards will find the network setup procedure for the MultiFlex boards to be very much the same.

#### 3.1 Wire Types

Copeland specs Belden #8641 shielded twisted pair cables for use as I/O network wiring (or Belden #82641 and Belden #88641 for plenum installations).

If the recommended cable is not available in your area, be sure the wiring meets or exceeds the following specs:

Table 3-1 - RS485 I/O Network Wiring Specifications

Shielded?	Yes
Conductor Type	Twisted Pair
Gauge	18 - 24 AWG
Capacitance between signal wires	31 pF/ft or less
Capacitance between signal and shield	59 pF/ft or less
Nominal Impedance	120Ω±50Ω

#### 3.2 Network Configuration (Daisy Chains)

The RS485 Input/Output (I/O) network is wired in a daisy-chain configuration. In a daisy chain, boards are wired together in series with no branches or “star configurations,” and the network is terminated at either end of the daisy-chain.

A diagram of this network arrangement is shown in Figure 3-1.

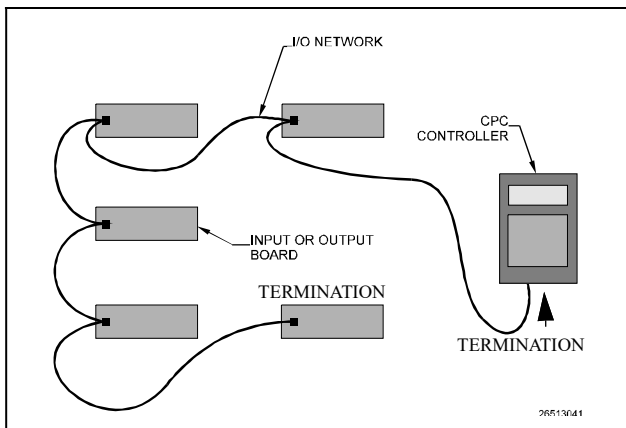

Figure 3-1 - I/O Network Configurations

#### 3.2.1 Maximum # of Boards on a Daisy Chain

To determine how many MultiFlex controllers may be daisy-chained together, look for a plus sign “+” at the end of the model type on the board’s plastic insulating cover.

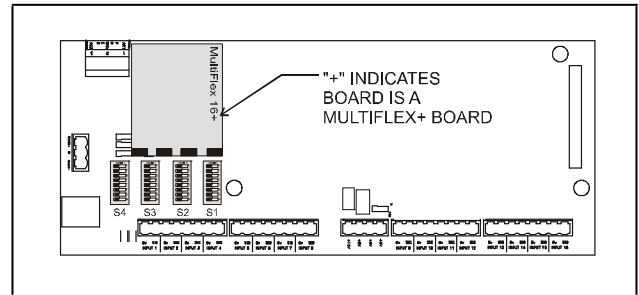

Figure 3-2 - MultiFlex “Plus” Board Indicator

The “+”, which appears on all MultiFlex boards manufactured after May 2004, means the board is equipped with a low-power network transmitter. Up to 256 of these boards may be connected to a single controller. If the board has no “+” beside the model type, the maximum number that can be connected to an E2 is 32.

If you have a mixture of plus and non-plus boards, multiply the number of non-plus boards by 8, and add that to the number of plus boards. This will result in the maximum number of boards you can interconnect.

#### 3.3 Network ID Numbers

Each device on an RS485 segment has a network dip switch that must be used to assign the board a unique **network ID number**.

The network ID number makes a board unique from other boards on the network of the same type. This allows the site controller to find it and communicate with it.

Boards of the same type should be numbered in sequence, starting with one and continuing with two, three, and so forth.

### 3.3.1 Numbering the MultiFlex 16

Both the MultiFlex16 and the previous-generation 16AI are recognized as “16AIs” by the site controller, and therefore each one of both types of boards should have a unique board number.

The network ID on the MultiFlex 16 is set using the first five dip switches on dip switch bank S3. Refer to **Figure 3-3** for dip switch setting instructions.

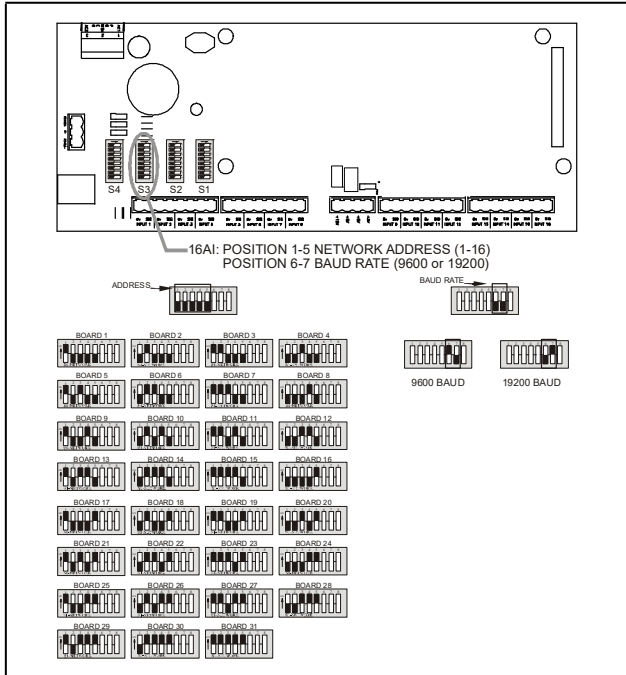

Figure 3-3 - 16 Network ID and Baud Rate Switches

### 3.3.2 Numbering for MultiFlex Combination I/O Boards

The “+”, which appears on all MultiFlex boards manufactured after May 2004, means the board is equipped with a low-power network transmitter. Up to 256 of these boards may be connected to a single controller. If the board has no “+” beside the model type, the maximum number that can be connected to an E2 is 32.

If you have a mixture of plus and non-plus boards, multiply the number of non-plus boards by 8, and add that to the number of plus boards. This will result in the maximum number of boards you can interconnect.

**Table 3-2** shows all of the combination MultiFlex I/O boards and the board numbers they represent.

**Table 3-2 - Model Types and Board Address Requirements**

MultiFlex Model Type	16AI	8RO	4AO	8DO
88 and 168	1	1		
88AO and 168AO	1	1	1	
168DO	1	1		1
1616L	1	2		
1616LAO	1	2	1	
1616LDO	1	2		1

Because the 1616 family of MultiFlex boards contains the same amount of relays as two 8RO boards, these boards must be configured as two 8RO boards with consecutive numbers. Selecting an address on the output switch will number the relay outputs as an 8RO with the selected address and a second 8RO of the next consecutive address (for example, setting the switch to #1 will number the relays as 8RO #1 and #2).

**Figure 3-4** provides a graphic representation of input and relay output board numbering for two MultiFlex 16s, three 8ROs, two MultiFlex 88 boards, and a 1616LAO. Note in this configuration that even though there are only 8 devices, they behave on the network as if they are 13 devices: 16AIs #1-5, 8RO #1-7, and 4AO #1.

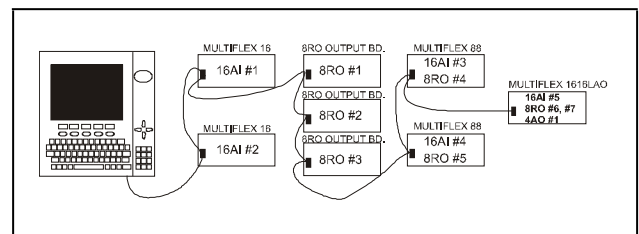

Figure 3-4 - Network Device Numbering (E2 Network Shown)

The board numbering dip switches on the MultiFlex 88, 88AO, 168, and 168AO are S3 and S4, as shown in **Figure 3-5**. Switches 1-5 on S3 set the input (16AI) network address. Switches 1-5 on S4 set the relay output (8RO) address, and switches 6-8 on S4 set the analog output (4AO) address.

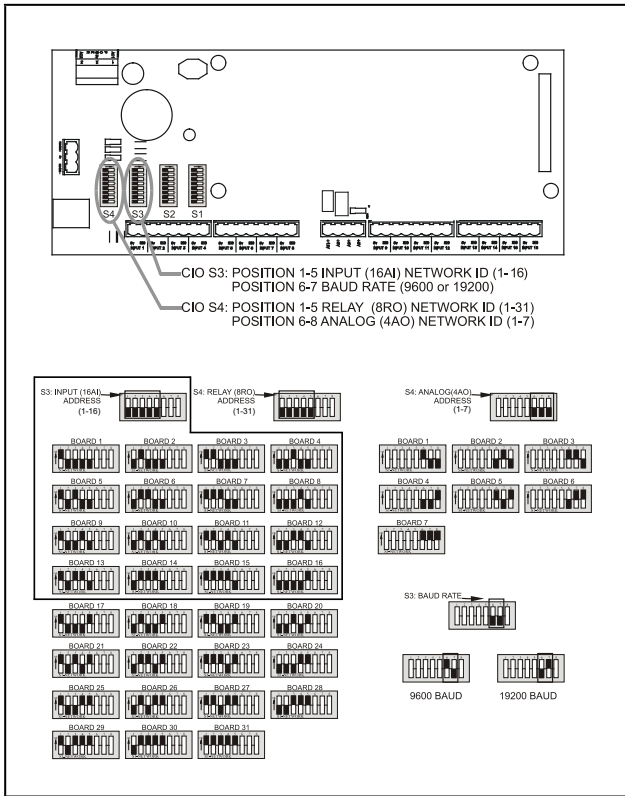

Figure 3-5 - 168AO Network ID and Baud Rate Switches

### 3.3.3 Addressing the 168DO

Setting up the network ID numbers for the 168DO is the same as setting up a 168AO (see **Section 3.3.2, Numbering for MultiFlex Combination I/O Boards**), except switches 6-8 on switch bank S4 set the virtual 8DO board address instead of the 4AO address as shown.

## 3.4 Setting the Baud Rate

All I/O boards have dip switches that determine the baud rate at which they communicate. Currently, the baud rate dip switch in network components may be set at either 9600 or 19200 baud. Either may be used -- refer to your site controller's user manual for the baud rate recommendation (currently 9600 baud for both REFLECS and Einstein controllers).

On all MultiFlex boards, switches 6 and 7 on S3 are used to set the baud rate. To communicate at **9600 baud**, set **switch #6 UP** and **#7 DOWN**. For **19200 baud**, set **switch #6 DOWN** and **#7 UP**. Refer to **Figure 3-3** and **Figure 3-5** for a visual look at how the switches must be set.

## 3.5 Setting the Terminating Resistance Jumpers

All MultiFlex boards and other RS485 devices have a set of terminating resistance jumpers (one jumper for each wire lead). These jumpers are labeled **JP2**, **JP3**, and **JP4** on the MultiFlex board.

The purpose of the jumpers is to indicate the two ends, or termination points, of the segment. On a daisy chain, one device at the beginning and one device on the end must be terminated. On the MultiFlex, this is done by placing all three termination jumpers in the OUT (toward the left edge of the board) position. To unterminate a MultiFlex, these jumpers must be set to the IN (toward the center of the board) position.

**Figure 3-6** shows the termination jumper settings for all MultiFlex boards.

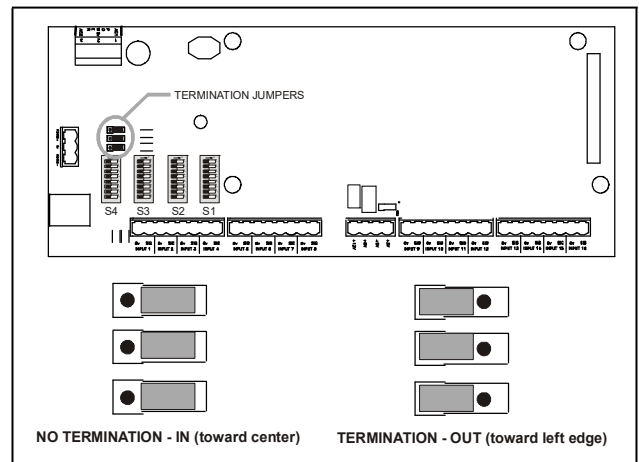

Figure 3-6 - I/O Network Termination Jumper Settings

## 4 I/O Board Input and Output Setup

### 4.1 The Inputs

The inputs on a MultiFlex board are compatible with a wide range of analog and digital sensors and transducers. In general, the inputs are capable of reading analog voltage signals in the range of 0V to +7VDC and dry-contact (no outside voltage) digital sensors and switches.

The specific types of input devices that must be used with MultiFlex is largely dependent on the site controller MultiFlex is connected to; refer to the site controller's user's manual for a full list of compatible sensors and specific sensor wiring instructions.

#### 4.1.1 Connecting Sensors to Input Boards

Wiring a sensor to the input points on a MultiFlex board requires three steps:

1. Connect the sensor's signal wires to the two terminals of an input point.
2. Set the input type dip switch that corresponds to the point being connected.
3. If necessary, connect the sensor to one of the 5V or 12V power terminals.

##### 4.1.1.1 Wiring

An input point on a MultiFlex board consists of two terminals, as shown in **Figure 4-1**. One of these terminals, labeled "SIG," reads the signal from the sensor, while the other, labeled "0V" is where the sensor's ground and/or cable shield wire is connected.

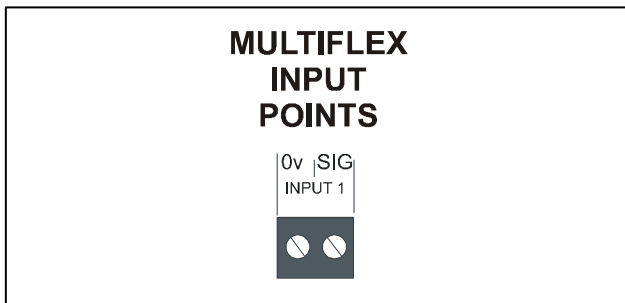

Figure 4-1 - Input Board Points

##### 4.1.1.2 Input Wiring When Replacing 16AI or CIO/8IO Boards With MultiFlex

If the MultiFlex you are installing is replacing an existing 16AI, CIO, or 8IO, you will not be able to simply unplug the input connectors from the old board and plug them into the MultiFlex. Doing so will cause the inputs to be reversed and the polarity to be swapped for points 1 through 8.

You must either re-wire points 1 through 8 to the proper place on the MultiFlex board, or obtain Multiflex input adapter cables (P/N 335-2301), as shown in **Figure 4-2**. For each 8-terminal connector plugged into points 1-4 and 5-8, unplug the connector from the old board and plug it into the female end of the adapter. Plug the male end into the appropriate MultiFlex input socket.

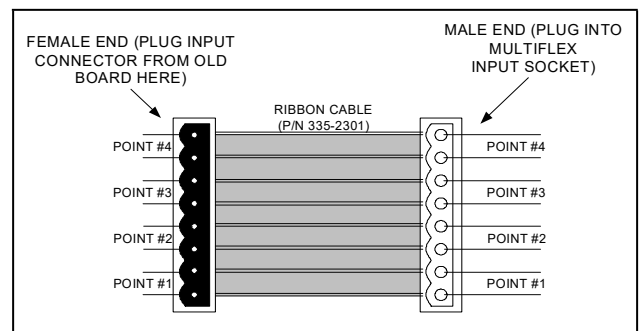

Figure 4-2 - MultiFlex Input Adapter Cable

The connectors for points 9-12 and 13-16 on the old board are already correctly oriented, and may be plugged directly into the new MultiFlex without an adapter cable.

### 4.1.1.3 Sensor Wiring Types

Specific wiring types are required for each type of sensor used with Einstein or RMCC.

#### All Analog Temperature Sensors and Air Flow Sensors

Temperature and air flow sensors are to be wired with shielded, 2 conductor, at least 22 GA wire (Belden # 8761 or equivalent).

#### All Pressure Transducers, Humidity Sensors, and Refrigeration Transducers

Pressure and refrigeration transducers and humidity sensors are to be wired with shielded, 3 conductor, at least 22 GA wire (Belden #8771 or equivalent).

#### Dew Point and Light Level Sensors

These sensors are to be wired with shielded, 4 conductor at least 22 GA wire (Belden # 8729 or equivalent).

### 4.1.1.4 Input Type Dip Switches

Each MultiFlex input point has an input type dip switch that must be set. Input type dip switches are located in the switch banks labeled **S1** and **S2**.

The input type dip switch tells the input board whether or not the sensor connected to the point is a resistive type sensor. Generally, if the sensor or transducer supplies its own voltage signal to the point, the dip switch should be set to the **LEFT (OFF) position**. If the sensor uses variable resistance and requires voltage to be supplied to it from the input point, set the dip switch to the **RIGHT (ON) position**. Dip switches for unused points should be set to the **RIGHT (ON) position**.

**The exception to this rule is for Copeland's 5VDC pressure transducers** -- though they supply their own voltage signal, the dip switch **MUST** be set to the **RIGHT (ON) position**.

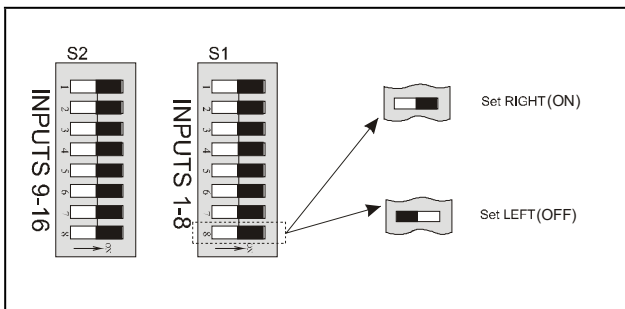

Figure 4-3 - Input Type Dip Switches for 16 Board

### 4.1.1.5 Pulse Type Inputs

The MultiFlex supports pulse accumulation inputs such as the kind supplied by some power transducers. Pulse accumulation inputs pulse a voltage at a certain rate that corresponds to a value.

If your site controller is an Einstein or a REFLECS BCU version 2.0 or above, you may connect pulse accumulation inputs to any point on the board.

If you have a REFLECS BCU with a version number below 2.0, an RMCC (any version) or a BEC (any version), you may only connect a pulse accumulation input to a single input on the MultiFlex board.

1. Connect the input to the point labeled **INPUT #1**. This is the only point on the board that may accept this type of input.
2. Locate **switch #8** on the dip switch bank labeled **S3** (the same one that sets input board network ID). Set **switch #8** to the **UP (ON)** position. This will tell the REFLECS that the input on point #1 is a pulse accumulation input.

### 4.1.2 Power Connection

If power is needed to operate the sensor, four points are provided on the MultiFlex board that supply DC power: one +12VDC point, and three +5VDC points. See **Figure 4-4** for the location of these points.

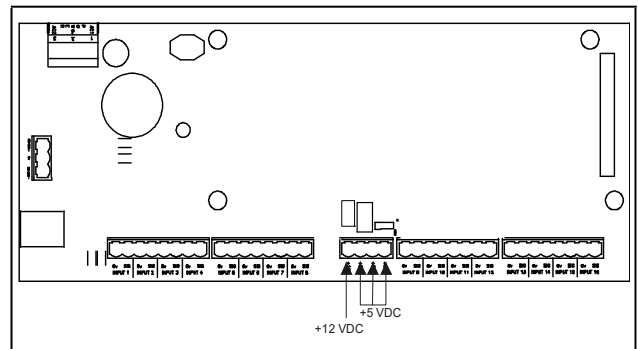

Figure 4-4 - Input Board Power Sources

#### 4.1.2.1 Current Ratings for On-Board Power Sources

The maximum current that may be drawn from the +12VDC terminal is 100 milliamps. The maximum current that can be drawn from all three +5VDC terminals **COMBINED** is 50 milliamps.



### 4.1.2.2 Powering Sensors Requiring 24VAC Off the Power Transformer

Some sensors that requires 24VAC can be powered off the MultiFlex’s own 24VAC power connection. To connect to the 24VAC power source, connect the sensor’s power wires to terminals AC1 and AC2.

This can only be done with sensors that keep the 24VAC signal isolated from its DC output signal (such as Copeland’s Dew Point Probe). If the output signal is not isolated from the 24VAC input, you must use a separate transformer.

### 4.1.3 Sensor Types for MultiFlex Input Points

Because different controllers may be compatible with different sensor types, this manual cannot list all sensor types and how to wire them to a MultiFlex input point. Refer to your site controller’s documentation for sensor wiring information.

## 4.2 The Relay Outputs

The MultiFlex Combination I/O boards have Form C relay contacts. **Figure 4-5** shows how to wire the three-terminal Form C contact.

One wire of the two-wire connection should always be connected to the middle terminal. The second wire must either be connected to the N.C. terminal (if you want the path to be closed when the relay is de-energized) or the N.O. terminal (if you want the path to be open during power failure).

The contacts you choose also affect what the board’s fail-safe dip switch will need to be set to for proper operation. Refer to **Table 4-1** and **Table 4-2**.

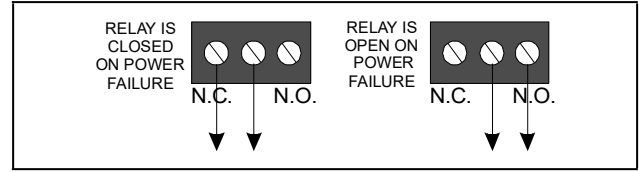

Figure 4-5 - Form C Contact Wiring

### 4.2.1 Output Fail-Safe Dip Switches

When a controller calls for a MultiFlex relay output to be ON, it sends a command to the MultiFlex to turn the output to the ON state (signified by the output LED being ON). The behavior of the relay when it is ON is determined by the position of the fail-safe switch. The fail-safe switches for the outputs are on a switch bank at the bottom right corner the plug-in output module. Each switch corresponds to an output on the board (switch # 1 = output #1, etc.).

**Table 4-1** and **Table 4-2** show how the fail-safe switch and Form C contacts should be configured based on how you want the output to perform during both normal operation and during network/power loss.

**NOTE: There are not many cases where you would want a relay to be OPEN when called to be ON. For most applications, you will want to set the fail-safe switch to UP so that an ON command from the controller will close the relay.**

Table 4-1 - Output Board Fail-Safe and Switch Settings when Contact is Wired Normally Closed (N.C.)

State of Normally Closed (N.C.) Contacts on MultiFlex Relay Points				
Fail-safe Switch	Light is ON	Light is OFF	Loss of Communication	Loss of Power
Up (ON)	Closed	Open	Closed	Closed
Down (OFF)	Open	Closed	Closed	Closed

Table 4-2 - Output Board Fail-Safe and Switch Settings when Contact is Wired Normally Closed (N.O.)

State of Normally Open (N.O.) Contacts on MultiFlex Relay Points				
Fail-safe Switch	Light is ON	Light is OFF	Loss of Communication	Loss of Power
Up (ON)	Open	Closed	Open	Open
Down (OFF)	Closed	Open	Open	Open

### 4.2.2 Relay Output Ratings and Fuse Protection

Each relay output on the MultiFlex Combination I/O boards is rated for up to 240 VAC with a maximum current of 2 amps.

Each relay is fused with a 2A fast-blow 5mm x 20mm fuse, Bussman GMA-2 or equivalent.

### 4.3 The Analog Outputs

All varieties of the MultiFlex board that have an "AO" at the end of their model number (88AO and 168AO) have four analog outputs that can provide a variable 0V - +10VDC signal to any of four variable-speed or variable-position devices. The maximum output current for each point is 10 milliamps.

The analog outputs have no hardware-based fail-safe settings (fail-safes are set in the board firmware; see **Section 6.1.9, Analog Fail-Safes**). All that is required to connect a device to an analog point is to connect the "+" terminal to the positive wire on the device and the "-" terminal to the negative (or ground) wire of the device.

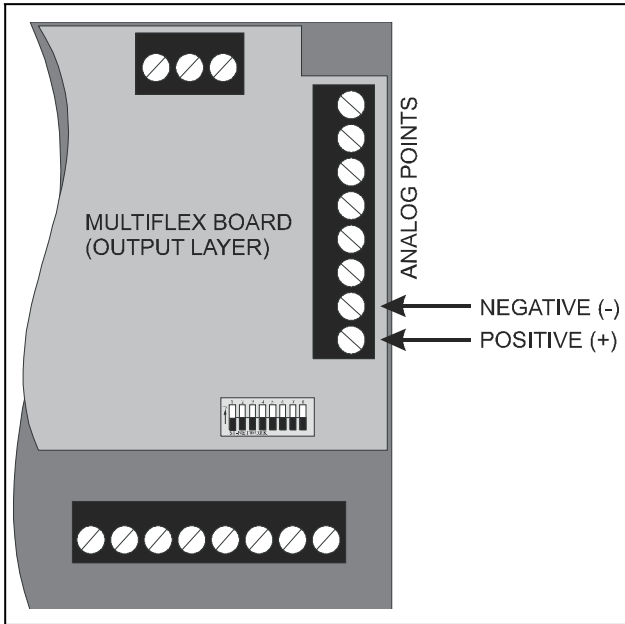

Figure 4-6 - MultiFlex Analog Points

### 4.4 The Digital Outputs

The MultiFlex 168DO board has four digital outputs that pulse a +8VDC signal. Each output is rated up to 10 milliamps.

The 168DO has no hardware-based fail-safe settings (fail-safes are set up in the board firmware). All that is required is to connect the "+" terminal to the positive wire on the device and the "-" terminal to the negative (or ground) wire of the device.

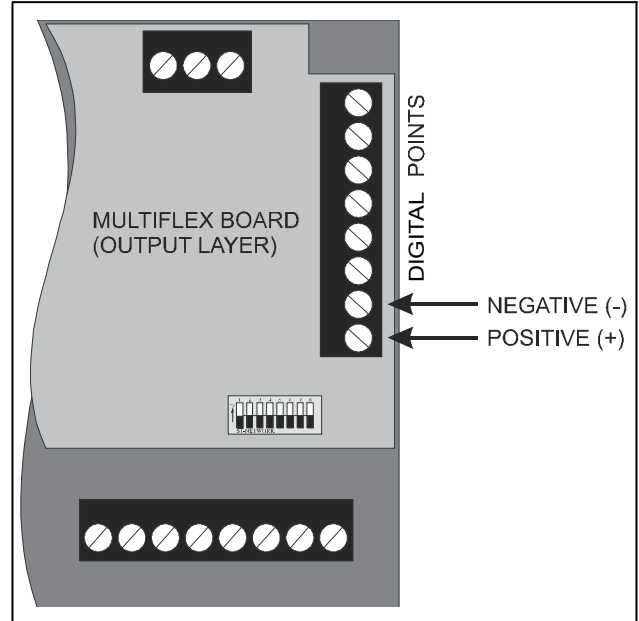

Figure 4-7 - MultiFlex Digital Points

## 5 Board Status LEDs

When a MultiFlex board is powered up, you will be able to determine the operating status of the board by observing its status LEDs. **Figure 5-1** shows the location of the MultiFlex's status LEDs.

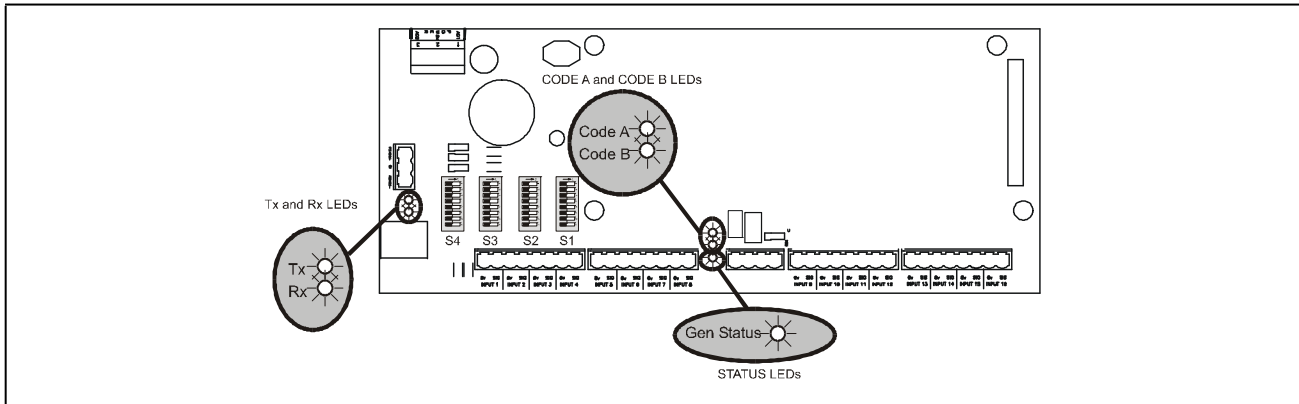

Figure 5-1 - MultiFlex Status LED Locations

### 5.1 Status LED

The Status LED simply blinks GREEN once per second to show that the board is powered and operational. If this light is dark, the board has likely lost power.

### 5.2 Tx and Rx LEDs

The Tx and Rx LEDs indicate when the MultiFlex is sending or receiving messages on the RS485 network.

The Tx LED blinks once every time the MultiFlex sends a response to the Einstein or REFLECS. The Rx LED blinks once when the MultiFlex receives a message.

If the MultiFlex is connected to the network and set up to communicate with the controller, you should see these lights blinking regularly. If they do not, there may be a problem with the network.

### 5.3 Code A and Code B LEDs

All MultiFlex I/O boards except the MultiFlex 16 have two LEDs labeled Code A and Code B. These LEDs indicate failure conditions. When these LEDs are OFF, there are no failures active. When one or both of these LEDs are blinking, there are failure conditions. The rate of blinking indicates the type of failure:

#### Code A Failure Conditions

- **Blinking fast (4 times/second)** - There is a problem with the flash memory or hardware clock on this board. This generally means the board is bad and must be replaced or flash memory could be corrupted.
- **Blinking slow (1 time/second)** - The board is not receiving any messages addressed to it. This means either the I/O network is down for more than 45 seconds, or it has not yet been commissioned in the supervisory controller Network Configuration screen.

#### Code B Failure Conditions

- **Blinking (2 times/second)** - This indicates the board has lost its configuration. For the MultiFlex I/O boards, a board is considered "configured" if you have specified input type settings and analog output fail-safes. If Code B blinks at this rate on an operational board, it means the board must be reprogrammed. This light does not blink if the board is new or is using the unmodified default configuration.
- **Blinking slowly (1 time/second)** - Battery is Low. *Only applicable to units that have battery.*

### 5.4 Relay Output LEDs

Each relay output point on a MultiFlex has an indicator LED that shows the status of the output. This LED is lit to show the output is ON, and unlit to show the output is OFF.

The definition of ON and OFF in this case is determined by the position of the fail-safe dip switch (see **Table 4-1** and **Table 4-2**).

## 6 The MultiFlex Hand-Held Terminal Interface

All MultiFlex boards have a Hand-Held Terminal interface, which can be used to view status for the board without having to use the site controller. Though different for each model of MultiFlex, the Hand-Held Terminal interface allows you to perform the same general functions:

- View failure messages that relate to the MultiFlex
- View the status of inputs (both in volts and in engineering units appropriate to the sensor type)
- View the current state of relay outputs (ON or OFF) and analog outputs (both in volts and in percentage)
- Override relay outputs to a fixed ON or OFF state, or override analog outputs to a fixed percentage
- Configure set points

### Plugging In the Hand-Held Terminal

The Hand-Held Terminal plugs into the RJ11 jack on the MultiFlex base board (located on the bottom left side of the board, as shown in **Figure 6-1**). Press the **Hand-Held Terminal connector** into the jack until it snaps into place. When the connector is correctly seated, the screen to the Hand-Held Terminal will display the message “**Handheld Terminal**” and then the first screen of the MultiFlex interface.

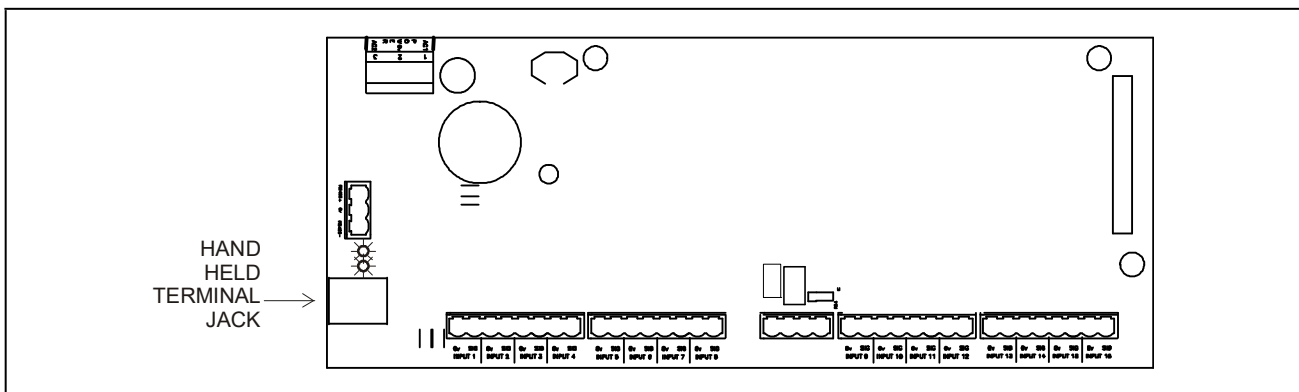

Figure 6-1 - MultiFlex HHT Jack Location

## 6.1 MultiFlex I/O Board Hand-Held Terminal Screens

### 6.1.1 Navigation

The Hand-Held Terminal interface consists of a simple series of screens and menus. **Figure 6-2** shows a complete map of all screens for the MultiFlex board(s). The options for working with inputs, relay outputs, and analog outputs stem from an Input/Output Select Menu, which will give you only the options appropriate for your board’s model type. This means if you are looking at a MultiFlex 16, there will be no options listed for viewing relay or analog outputs. If you are using a MultiFlex 88 or 168, there will be no analog or digital output options.

### Scrolling Through The Hand-Held Screens

The **UP ARROW** and **DOWN ARROW** keys are used to scroll through the screens. Some of these screens, shown as dotted-line boxes in **Figure 6-2**, are read-only, meaning there are no editable fields; others, shown as solid-line boxes, are either menus that require you to enter a selection or are configuration screens that have one or more changeable fields.

### Shortcut Keys (F1 and F2)

At any time, you may press the **F1** key on the Hand-Held Terminal to return to the opening screen, or **F2** to move to the **Input/Output Select** menu.

### Configuration Mode

On any menu or configuration screen, to make a selection or enter a value you must press the **RIGHT ARROW** key to begin Configuration Mode.

In Configuration Mode, you will see a cursor shaped like an arrow pointing right. Use the **UP ARROW** and **DOWN ARROW** keys to move the cursor to the field you want to change. Then, use the number keys to enter a value, or if the field requires a selection from a list of options, use the **"point key"** (.) and the **"dash key"** (-) to cycle through the options. To record your change, simply press the **UP ARROW** or **DOWN ARROW** key to move the cursor to another field.

To exit **Configuration Mode**, use the **UP ARROW** or **DOWN ARROW** keys to move the cursor off the screen. When it is no longer visible, you are no longer in Configuration Mode and may navigate normally.

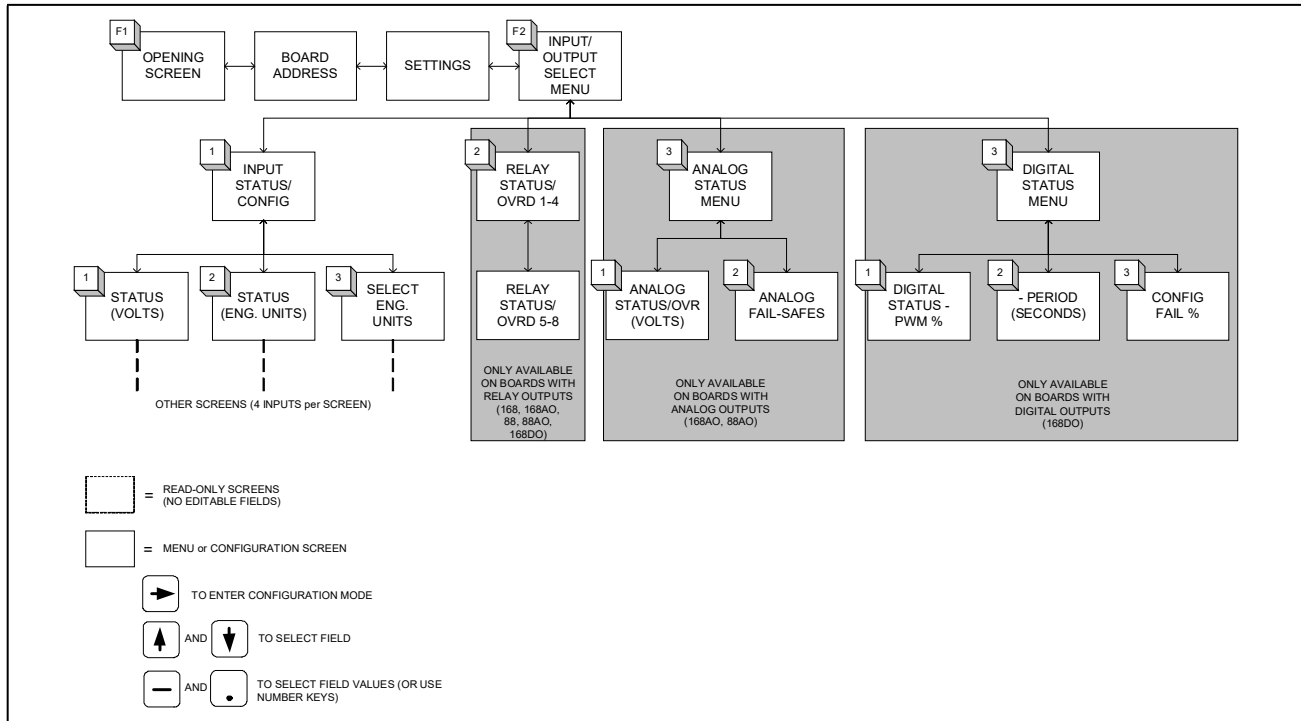

Figure 6-2 - MultiFlex I/O Board Hand-Held Terminal Interface Navigation Map

### 6.1.2 Opening Screen

```
MULTIFLEX 16
810-3013
VER: 1.00F01
(PRESS ↓)
```

**NOTE** At any time, pressing F1 on the Hand-Held Terminal will return you to this screen.

When the Hand-Held Terminal is first plugged in to a MultiFlex board, the opening screen will display the model type, Copeland part number, and version number of the board software.

The last line of the display will also show if any failure conditions are active. If there are failure conditions, the last line will display the message **"FAIL."** followed by a description of the condition. If there is no failure condition, the last line of the display will prompt the user to press the **DOWN ARROW** key to continue.

### 6.1.3 Board Address

#### 168AO Screen

```
Board Address:
16AI: 1
8RO: 1
4AO: 1
```

#### 168DO Screen

```
Board Address:
16AI: 1
8RO : 1
8DO : 1
```

The Board Address screen shows the current board address settings for the MultiFlex. The numbers shown here are read directly from the network address dip switch settings on the board. This screen does NOT allow you to change the board numbers with the Hand-Held Terminal; this must be done by setting the network address dip switches. Refer to **Section 3.3, Network ID Numbers**, for dip switch setting information.

The MultiFlex will not display address numbers that do not pertain to the model type. In other words, a MultiFlex 16 will not show fields with the 8RO and 4AO address numbers, and an 88 or 168 will not show a field for the 4AO address number.

If an 16AI, 8RO, or 4AO field that is supposed to appear on this screen is not shown, it is because the board number dip switches for these board types are set to "0." Set the **8RO** and **4AO dip switch settings** to a unique number (refer to **Section 3.3.2, Numbering for MultiFlex Combination I/O Boards**). The Hand-Held Terminal should update within a few seconds and show the 8RO and 4AO board numbers.

## 6.1.4 Settings

```
Settings:
Baud: 9600
In 1 Pulse? NO
```

This screen shows the baud rate dip switch setting for the board, and the position of S3 switch #8, which is required to be UP for all RMCC (all versions), BEC (all versions), and BCU (versions below 2.0) units if pulse accumulation inputs are being used. This screen does NOT allow you to change the baud rate or pulse settings with the Hand-Held Terminal; this must be done by setting the dip switches. Refer to **Section 3.4, Setting the Baud Rate** and **Section 4.1.1, Connecting Sensors to Input Boards** for more information about these dip switch settings.

## 6.1.5 Input/Output Select Menu

### 168AO Screen

```
SELECT: 1
1= Inputs
2= 8 Relay Outs
3= 4 Analog Outs
```

### 168DO Screen

```
SELECT: 1
1= Inputs
2= 8 Relay Outs
3= 4 DO PWM Outs
```

This menu is where you select whether you want to view the board's inputs, relay outputs, or analog outputs. To select, press the **RIGHT ARROW** key to make the cursor appear, and then enter either 1 (for inputs), 2 (for relay outputs), or 3 (for analog outputs on the 4AO, or digital outputs on the 8DO). Then, press the **DOWN ARROW** key once to exit Configuration Mode and **DOWN ARROW** again to access the first status screen for the selection you made.

## 6.1.6 Input Screens

### 6.1.6.1 Input Status/Config Menu

```
SELECT: 1
1= STATUS-VOLTS
2= STATUS-ENG UN
3= INPUT CONFIG
```

The Input Status/Config Menu offers three choices:

1. **STATUS-VOLTS** - Selecting this option will show the status of all the inputs in volts.
2. **STATUS-ENG UN** - Selecting this option will show the status of all the inputs in engineering units. Engineering units must be specified for each input using the **Input Config screens (option 3)**, or else the board assumes the input is a temperature sensor and will display the input value in degrees Fahrenheit.
3. **INPUT CONFIG** - Selecting this option will allow you to specify the engineering units for each sensor connected to an input. Doing this will allow you to see the sensor value in terms of its intended engineering units.

### 6.1.6.2 Status-Volts

```
I01: 5.000 V
I02: 5.000 V
I03: 5.000 V
I04: 5.000 V
```

The Status-Volts screen shows the current input voltage of all inputs on the MultiFlex board. Units with no inputs attached to them (and with their input dip switches set to the UP position) will read 5 volts.

The Hand-Held Terminal shows four inputs at a time. To view more inputs, press the **DOWN ARROW** key to scroll down.

### 6.1.6.3 Status-Eng Units

```
I01: 74.500 DF
I02: 111.200 PSI
I03: 75.200 DF
I04: 65.04 RH
```

The Status-Eng Units screen shows the same information as the Status-Volts screen, except it displays it in the engineering units designated for that input (see **Section 6.1.6.4, Input Config** for more on how to set the engineering units). The engineering unit chosen for the input is displayed in the right-hand column.

The Hand-Held Terminal shows four inputs at a time. To view more inputs, press the **DOWN ARROW** key to scroll down.

### 6.1.6.4 Input Config

I01: TEMP-DF  
 I02: 500 LB-PSI  
 I03: TEMP-DF  
 I04: HUMIDITY-RH

The Input Config screen is where you specify the type of sensor that is attached to each input and the engineering unit with you wish to display the input values in the Hand-Held Terminal.

Setting the engineering units using these screens will only affect how their values are displayed in the STATUS-ENG UNITS screen (**Section 6.1.6.3, Status-Eng Units**). Currently, neither Einstein nor REFLECS is capable of reading the MultiFlex’s engineering units settings, so the sensor type and engineering units will still have to be specified in the controller in order for the inputs to be read correctly.

Fields I01 through I16 correspond to points 1 through 16 on the MultiFlex board. To change the engineering unit for an input, press the **RIGHT ARROW** key to enter Configuration Mode, and press **DOWN ARROW** until the cursor points to the field you wish to change. Use the **POINT (.)** and **DASH (-)** keys to scroll through the sensor types and units supported by Copeland controllers. **Table 6-1** lists all the possible engineering unit settings.

**Table 6-1 - Engineering Units for MultiFlex Inputs**

Field Value	Sensor Type	Units
TEMP-DF	Temperature Sensor	DF (°F)
TEMP-DC	Temperature Sensor	DC (°C)
100-LB PSI	12V Copeland 100-PSI transducer	PSI
100-LB KPA	12V Copeland 100-PSI transducer	KPA
200-LB PSI	12V Copeland 200-PSI transducer	PSI
200-LB KPA	12V Copeland 200-PSI transducer	KPA
500-LB PSI	12V Copeland 500-PSI transducer	PSI
500-LB KPA	12V Copeland 500-PSI transducer	KPA
ECLP100-PSI	5V 100-PSI pressure transducer	PSI
ECLP100-KPA	5V 100-PSI pressure transducer	KPA
ECLP200-PSI	5V 200-PSI pressure transducer	PSI
ECLP200-KPA	5V 200-PSI pressure transducer	KPA
ECLP500-PSI	5V 500-PSI pressure transducer	PSI
ECLP500-KPA	5V 500-PSI pressure transducer	KPA
HUMIDITY-RH	Humidity sensor	RH (%)
POWER-KW	Power transducer with 1-5V output (NOT pulse count output)	KW
REF LEAK	Refrigerant Leak Transducer	PPM
DEW PT-DF	Dewpoint Probe	DF (°F)
DEW PT-DC	Dewpoint Probe	DC (°C)
LM235-DF	LM235 Temperature Sensor	DF (°F)
LM235-DC	LM235 Temperature Sensor	DC (°C)
REF LEVEL	Refrigerant Liquid Level Probe (Hansen)	PCT (%)
LIQ LEVEL	Analog Liquid Level (Float-Type) Indicator	PCT (%)

Table 6-1 - Engineering Units for MultiFlex Inputs

Field Value	Sensor Type	Units
LIGHT-FTC	Light Level Sensor	FTC (foot-candles)
LIGHT-LUX	Light Level Sensors	LUX
PULSE COUNT	Pulse count input	None
DIG-ON/OFF	Digital (ON/OFF) input	ON/OFF
LINEAR-V	Standard 0-5V Linear Analog Input	V
HI-TEMP-DF	Hi Temp Sensor	DF
HI-TEMP-DC	Hi Temp Sensor	DC
SETPT ADJ	Slide potentiometer used for set point adjustment	PCT (%)
NOT USED	Selecting this will cause the input value to read "UNUSED" on the STATUS-ENG UNITS screen.	None.

### 6.1.7 Relay Output Screens

```
R01: OFF
R02: OFF
R03: ON
R04: OFF
```



**WARNING** Point overrides performed by HHT are not visible to or recognized by the MultiFlex's parent controller. In some cases, this may cause unnecessary proof failure alarms and other erroneous conditions. If a site controller is available, it is recommended all overrides be performed from the site controller instead of the HHT.

The Relay Output Screens show the on/off status of the MultiFlex's relay outputs. The fields numbered R01 through R08 correspond to relay points #1 through #8 on the board.

#### Overriding a Relay Output

You may temporarily override any relay output to a fixed ON or OFF state using the Hand-Held Terminal interface.

To begin an override, press the **RIGHT ARROW** key to enter Configuration Mode, and use the **DOWN ARROW** key to move the cursor to the output you wish to override.

```
R01: OFF OVR→ON
R02: OFF
R03: ON
R04: OFF
```

Press the **DASH** key to choose an override command. "**OVR ON**" will override the output **ON**, and "**OVR OFF**" will override the output **OFF**. To begin the override, press the **DOWN ARROW** key.

#### Cancelling an Override

To cancel an override, move the cursor to the field that says **OVR ON** or **OVR OFF** and press the "**CANCEL**" button on the Hand-Held Terminal.

You may also cancel all active overrides in the MultiFlex board by unplugging the Hand-Held Terminal. This will reset all relay output and analog output overrides.

If you need timed overrides or permanent overrides that do not require the Hand-Held Terminal to remain plugged in, you must perform the override from the REFLECS or Einstein front panel.



## 6.1.8 Analog Output Screens

### 6.1.8.1 Analog Status/Override

```
A01:10.0  
A02:10.0  
A03:10.0  
A04:10.0
```

This screen shows the current voltage output of each of the four analog outputs on the MultiFlex board. The fields numbered **A01 through A04** correspond to analog points #1 through #4 on the board.

#### Overriding an Analog Output



**Point overrides performed by HHT are not visible to or recognized by the MultiFlex's parent controller. In some cases, this may cause unnecessary proof failure alarms and other erroneous conditions. If a site controller is available, it is recommended all overrides be performed from the site controller instead of the HHT.**

You may temporarily override any analog output to any voltage between 0 and 10 volts using the Hand-Held Terminal interface.

To begin an override, press the **RIGHT ARROW** key to enter **Configuration Mode**, and use the **DOWN ARROW** key to move the cursor to the output you wish to override.

```
A01:10.0 OVR→5.5  
A02:10.0  
A03:10.0  
A04:10.0
```

Use the number keys to enter the voltage value you wish to override the output to. The number you enter may have up to one decimal place.

When you have entered the override value, press the **DOWN ARROW** key to begin the override.

#### Cancelling an Override

To cancel an override, move the cursor to the override value and press the **"CANCEL"** button on the Hand-Held Terminal.

You may also cancel all active overrides in the MultiFlex board by unplugging the Hand-Held Terminal. This will reset all relay output and analog output overrides.

If you need timed overrides or permanent overrides that do not require the Hand-Held Terminal to remain plugged in, you must perform the override from the REFLECS or Einstein front panel.

### 6.1.9 Analog Fail-Safes

```
A01: 100%  
A02: 100%  
A03: 100%  
A04: 100%
```

This screen allows you to set the values each analog output will be set to when the MultiFlex loses communication with the Einstein or REFLECS.

Fail-safe mode begins whenever the MultiFlex has received no communication with the Copeland site controller for five minutes. At this time, the MultiFlex forces all analog outputs to the percentage values specified in this screen. The default is 100%, but the value may be set to any value between 0-100%.

To change the fail-safe value, press the **RIGHT ARROW** key to enter Configuration Mode, and press the **DOWN ARROW** key until the cursor points to the value you wish to change. Using the number keys, enter a percentage value from 0 to 100. To save your fail-safe setting, press the **DOWN ARROW** key.

### 6.1.10 Digital Status (PWM)

```
D01:100 %  
D02:100 %  
D03:100 %  
D04:100 %
```

This screen shows the current pulse percentage of each of the four digital outputs on the 168DO. The percentage represents the total amount of the pulse period the output is ON (+8VDC).

To view the pulse period, back out of this screen by pressing the **UP ARROW** key, and from the **Digital Output** menu, select **option 2** (see **Section 6.1.11, Digital Period Status**).

## Overriding a DO point from the HHT

### WARNING

Point overrides performed by HHT are not visible to or recognized by the MultiFlex's parent controller. In some cases, this may cause unnecessary proof failure alarms and other erroneous conditions. If a site controller is available, it is recommended all overrides be performed from the site controller instead of the HHT.

From this screen, the digital output points may be overridden to a fixed percentage. Press the **RIGHT ARROW** key to make the cursor appear, and use the **DOWN ARROW** keys to select the point you wish to override. Enter a number from **0 to 100** that you wish to override the point to, and press the **UP** or **DOWN ARROW** key to save changes and move the cursor.

When pulsing during an override, the 168DO will use the pulse period at which the output was pulsing before the override began. If the output was being controlled by an application in a Copeland site controller, the period used will be the same period programmed in the controller.

### Canceling an Override

An override initiated from an HHT can be cancelled from the same screen in which you initiated the override (the Digital Status (PWM) screen). Move the cursor until the arrow points to the point with the override you wish to cancel, and press the **CANCEL** button on the HHT.

## 6.1.11 Digital Period Status

D01:	10	Period
D02:	10	in
D03:	10	Seconds
D04:	10	

The Digital Period Status screen shows the current period (in seconds) at which the four outputs on the 168DO are pulsing. This value is read from the Copeland site controller that commands the output and may not be changed from the HHT.

## 6.1.12 Config Fail % Screen

D01:	100%	Off
D02:	100%	line
D03:	100%	(Fail)
D04:	100%	PCT

This screen sets the default percentage at which the digital outputs on the 168DO will pulse if communication is lost with the site controller. When the board recognizes it is off-line, it will immediately switch to its fail-safe percentage, and will remain at this rate until the board returns to on-line status. The 168DO will use the same pulse period it used before the board went off-line.

If a digital output is not being commanded by any applications in the site controller, it will pulse at the value programmed in its Config Fail % field regardless of whether or not the board is on-line or off-line.

## 7 Relay Output Test Mode

Newly released versions of the MultiFlex I/O board family and the 8ROSMT have a new feature that allows relays to be manually energized and de-energized without use of an override from a Hand-Held Terminal when the board is offline. When a MultiFlex is in Relay Output Test Mode, the output fail-safe dip switches may be used to cycle the states of the relay outputs. The feature is designed to help manufacturers of panels test output wiring quickly and easily without need for a site controller or HHT.

Relay Output Test Mode is available in the following product versions:

**Table 7-1 - Board Versions Available in Relay Output Test Mode**

Board Type	Version
8RO-SMT output board	1.20F01 and above
MultiFlex 168, 88, 168AO, and 88AO combination input/output boards	1.60F01 and above
MultiFlex 168DO combination input/output boards with digital outputs	1.60F01 and above
MultiFlex 1616LAO and 1616LDO combination input/output boards	1.3F01 and above
MultiFlex 1616L combination input/output board without analog outputs	1.2F01 and above

To activate Relay Output Test Mode for MultiFlex, set switches 1-8 on DIP Switch banks S3 and S4 to the OFF (LEFT) position. For 8ROSMT, set switches 1-8 on DIP Switch bank S1 (NETWORK) to the OFF (DOWN) position. The board will enter Relay Output Test Mode.

In Relay Output Test Mode, fail-safe dip switches 1-8 (located on the output board layer of MultiFlex I/O boards, and next to switch bank S1 on the 8ROSMT) can be used to change the state of the relays.

A fail-safe switch in the ON position will cause the corresponding relay to be energized (i.e., OPEN on the N.C. terminals, and CLOSED on the N.O. terminals). A fail-safe switch in the OFF position will cause the relay to be de-energized (i.e., CLOSED on the N.C. terminals and OPEN on the N.O. terminals).

The LED that shows the output state will also be ON when the switch is ON and OFF when the switch is OFF.

To exit Relay Output Test Mode, set the address switches S3 and S4 to any position other than "all OFF." The fail-safe switches will Board Type Version resume normal operation.

# MULTIFLEX I/O BOARD - RELAY OUTPUT TEST MODE

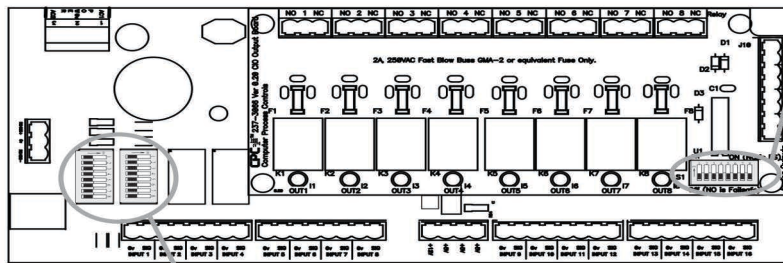

SET ALL SWITCHES ON S3 & S4 TO OFF POSITION (LEFT) TO ENABLE RELAY OUTPUT TEST MODE

IN RELAY OUTPUT TEST MODE, FAIL-SAFE SWITCHES MAY BE USED TO TEST RELAYS.

- LED OFF, N.C.=CLOSED, N.O.=OPEN
- LED ON, N.C.=OPEN, N.O.=CLOSED

# 8ROSMT - RELAY OUTPUT TEST MODE

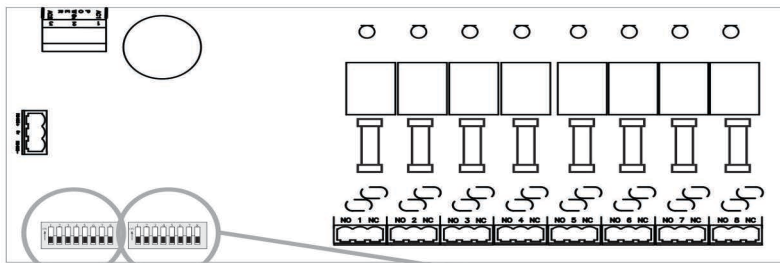

SET ALL SWITCHES ON S1 TO OFF POSITION (DOWN) TO ENABLE RELAY OUTPUT TEST MODE

IN RELAY OUTPUT TEST MODE, FAIL-SAFE SWITCHES MAY BE USED TO TEST RELAYS.

- LED OFF, N.C.=CLOSED, N.O.=OPEN
- LED ON, N.C.=OPEN, N.O.=CLOSED

Figure 7-1 - Relay Output Test Modes

*For more product information,  
scan the QR Code:*



Visit our website at [copeland.com/en-us/products/controls-monitoring-systems](https://copeland.com/en-us/products/controls-monitoring-systems) for the latest technical documentation and updates.  
For Technical Support call **833-409-7505** or email **ColdChain.TechnicalServices@Copeland.com**

The contents of this publication are presented for informational purposes only and they are not to be construed as warranties or guarantees, express or implied, regarding the products or services described herein or their use or applicability. Copeland reserves the right to modify the designs or specifications of such products at any time without notice. Responsibility for proper selection, use and maintenance of any product remains solely with the purchaser and end-user.  
©2024 Copeland is a trademark of Copeland LP.