

Copeland™ Scroll ZXV Variable Speed Condensing Unit

for Refrigeration Applications



User manual

COPELAND™

EMERSON™

ZXV condensing unit



Emerson is pleased to offer the ZXV/ZXLV variable speed condensing units from ZX platform, especially designed for refrigeration applications.

Overall, ZX platform CDU (ZX and ZXB medium temperature, ZXL low temperature, ZXD/ZXLD digital modulated capacity medium temperature and low temperature, ZXV/ZXLV variable speed medium temperature and low temperature refrigeration) has been highly successful in the Asian market and enjoys proven success with its energy savings and customer-friendly electronic features.



Table of contents

Disclaimer	04
Features and benefits	05
Nomenclature	05
Bill of material	05
Physical layout of the unit	06
ZXV Product specification	08
Qualified refrigerants and oils	08
Operating envelopes	08
Performance data	09
Technical data	11
CoreSense controller	12
Network wiring	17
Installation	19
Condensing unit handling	19
Electrical connection	19
Refrigeration piping installation	20
Liquid line insulation	20
Brazing recommendations	20
Location and fixing	21
Start up and operation	21
Vacuuming	21
Charging procedure	21
Check before starting & during operation	22
ZXV do's and don'ts	22
Alarm codes	23
Wiring diagrams	27
Temperature sensor resistance	27
Contact lists	32



ZXV condensing unit for refrigeration applications

Disclaimer

Thank you for purchasing the ZXV condensing unit from Emerson. ZX platform CDUs are the best in class within the capacity and operating range available in the market. ZX CDU is designed to operate reliably and to deliver high operating efficiencies in medium and low temperature refrigeration applications. It also provides constant monitoring of the compressor operating conditions and displays the running or fault conditions of the CDU. ZX platform CDUs have to be installed by following the industry trade practices for its safe and reliable operation. It is assumed that the CDU is selected, installed and serviced only by professionals. The user manual does not cover good industry practices which are essential on a refrigeration equipment installation. No responsibility can be accepted for damage caused by inexperienced or inadequately trained site technicians or improper installation design.

If in doubt, please consult your local sales office, quoting unit model and serial number as shown on each unit nameplate. In case of any ambiguity, the wiring diagram supplied with each unit takes precedence over the diagram in this manual.

Introduction to ZX platform CDU

ZX and ZXB medium temperature, ZXL low temperature, ZXD/ZXLD digital modulated capacity medium temperature and low temperature, ZXV/ZXLV variable speed medium temperature and low temperature series have been highly successful in the Asian market and enjoys proven success with its energy savings and customer-friendly electronic features. ZX platform CDUs have been applied by several well-known end-users and chain retailers throughout Asia. The ZX platform is also gaining wider acceptance in the global market and specific variants have been developed and exported to the US, European and Middle East markets.

Receiving your unit

All units are shipped with a holding charge of dry nitrogen inside at a low but positive pressure. Suitable labeling is prominently displayed on both the unit and the packaging. Service connectors are provided on the CDU service valve for the convenient checking of the integrity of the holding charge.

Caution! It is very important to check that this holding pressure exists at the time you receive each unit from us or our authorized representatives. Please inform us or our authorized representative if the holding charge is non-existent. Failure to do so could void the claim for other related system faults at a later period.

Transit damage is essentially an insurance claim and is not covered under manufacturing defect. It is also advisable to inspect the rest of the unit for obvious physical damage and inform us or our authorized representative in case any damage is discovered.

ZX platform condensing unit was designed based on three factors demanded by industry users

Intelligent Store™ solution - A most innovative approach to enterprise facility management, Intelligent Store by Emerson architecture integrates hardware and services, to provide retailers a single view into their entire network of facilities and understanding what facilities actually cost to operate and maintain.

The Intelligent Store architecture transforms data from store equipment and controls into actionable insights. Designed to deliver value in both new and existing stores, Emerson aims to help the retailers:

- Make better decisions on recourse investment for greatest impact
- Gain accurate feedback and customized service for your specific needs
- Reduce operational costs and boosting profitability

Energy efficiency - Utilizing Copeland™ scroll compressor technology, variable speed fan motor, large capacity condenser coil and advanced control algorithms, energy consumption is significantly reduced. End-users can save more than 20% on annual energy costs compared to using hermetic reciprocating units.

Reliability - Combining the proven reliability of Copeland scroll compressors with advanced electronic controllers and diagnostics, equipment reliability is greatly enhanced. Fault code alerts and fault code retrieval capabilities provide information to help improve speed and accuracy of system diagnostics. Integrated electronics provide protection against over-current, over-heating, incorrect phase rotation, compressor cycling, high pressure resets and low pressure cut-outs. It can also send out a warning message to an operator when there is a liquid floodback, which can prevent critical damage on the unit.

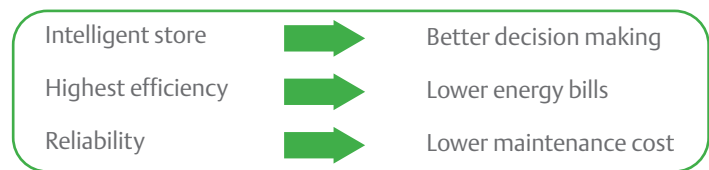

ZXD, ZXLD, ZXV Family
Capacity modulation digital and variable speed to control precise room or showcase temperature



ZX, ZXB and ZXL Family
Proprietary electronic algorithms present advantage on diagnose, communication, and protection purposes. They are also fundamental to control fan speed, optimizing energy performance for local seasonal ambient temperatures

Design features:

- With real time monitoring of compressor operating conditions
- Compressor reverse rotation protection
- Compressor over current protection
- Compressor internal motor protector trip
- Discharge gas over heat protection
- Over voltage protection
- Under voltage protection
- High pressure cut out
- Low pressure cut out
- Refrigerant flood back protection
- Compressor minimum off time protection
- Internal thermal sensor failure
- Intelligent Store solution:
 - Communication and retail store monitoring
 - Thermal overload protection

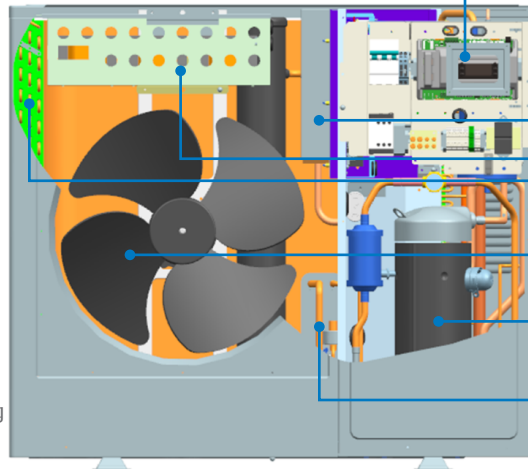

- Drive assembly**
 - High reliability with good cooling
 - Easy service with quick connectors
- Good harmonic with choke
- Optimized condenser coil for maximum heat transfer
- Variable speed fan motor and high efficiency fan blade
- Copeland™ scroll compressor technology**
High efficiency, ultra quiet, high reliability
- Enhanced vapor injection**
 - Improved efficiency
 - Combined DLT protection

Figure 1. ZVX CDU features

ZXV nomenclature

Z	X	V	0	6	5	B	E	-	4	X	D	4	5	1
Condensing platform	V = Medium temp variable speed LV = Low temp variable speed	Maximum capacity*	B = Next generation	P = R410A, POE oil E = R404A, POE oil							4XD = 3 phase, 380-420V, 50Hz 4XK = 3 phase, 380-420V, 60Hz 5XJ = 3 phase, 200-240V, 60Hz (5XJ in sample)	Bill of material 451 = Chassis with hinged door 551 = Chassis with front panel		
												Bill of material		
Base model									Electrical code			Bill of material		

Note: *Maximum capacity condition of evap temp/amb temp/return gas temp
Medium temp -10°C/40°C/18.3°C
Low temp -32°C/40°C/5°C

Bill of material

ZXV BOM	ZXV	ZXLV
	451, 551	451, 551
Liquid line filter drier	✓	✓
Moisture indicator	✓	✓
Oil separator	✓	✓
Accumulator		✓*
Suction pressure transducer	✓	✓
Fixed HP switch	✓	✓
Fixed LP switch	✓	✓
Adjustable LP switch		✓
CoreSense & Intelligent Store	✓	✓
Fan speed control	✓	✓
Circuit breaker	✓	✓
Sound jacket	✓	✓

Note: * Accumulator is shipped in loose packing for single fan ZXLV units

Physical layout of the unit

The following figures give an introduction to the physical layout of the ZXV CDU

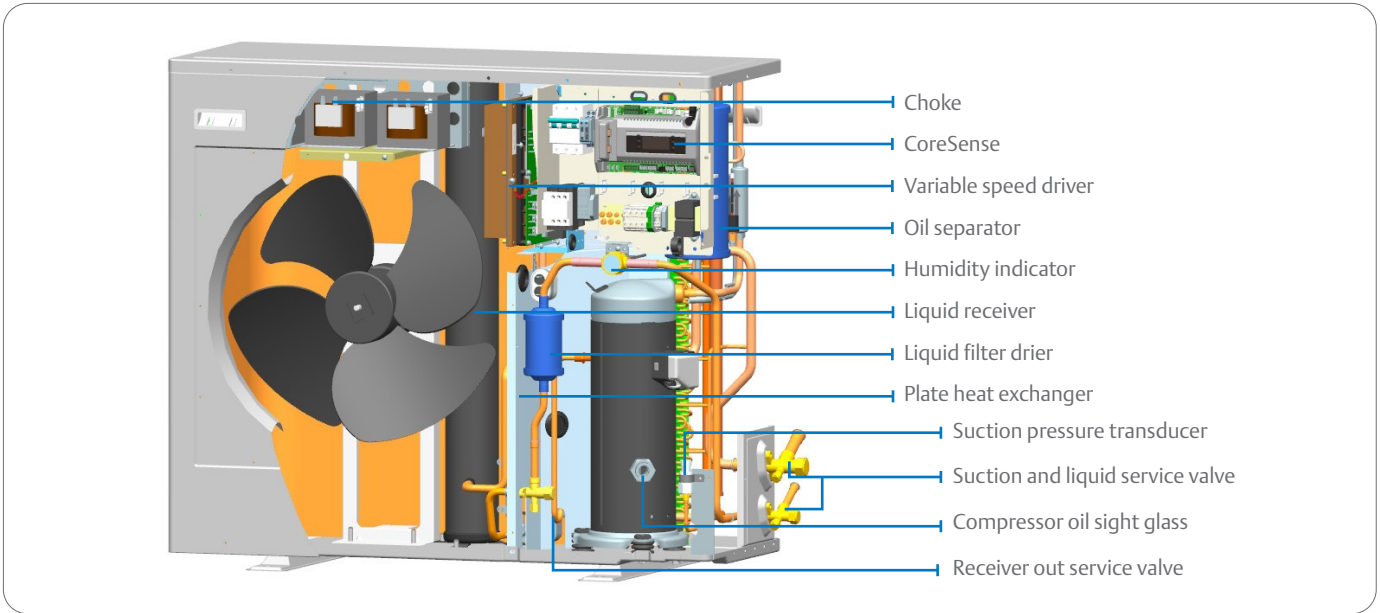

Figure 2. ZXV CDU layout

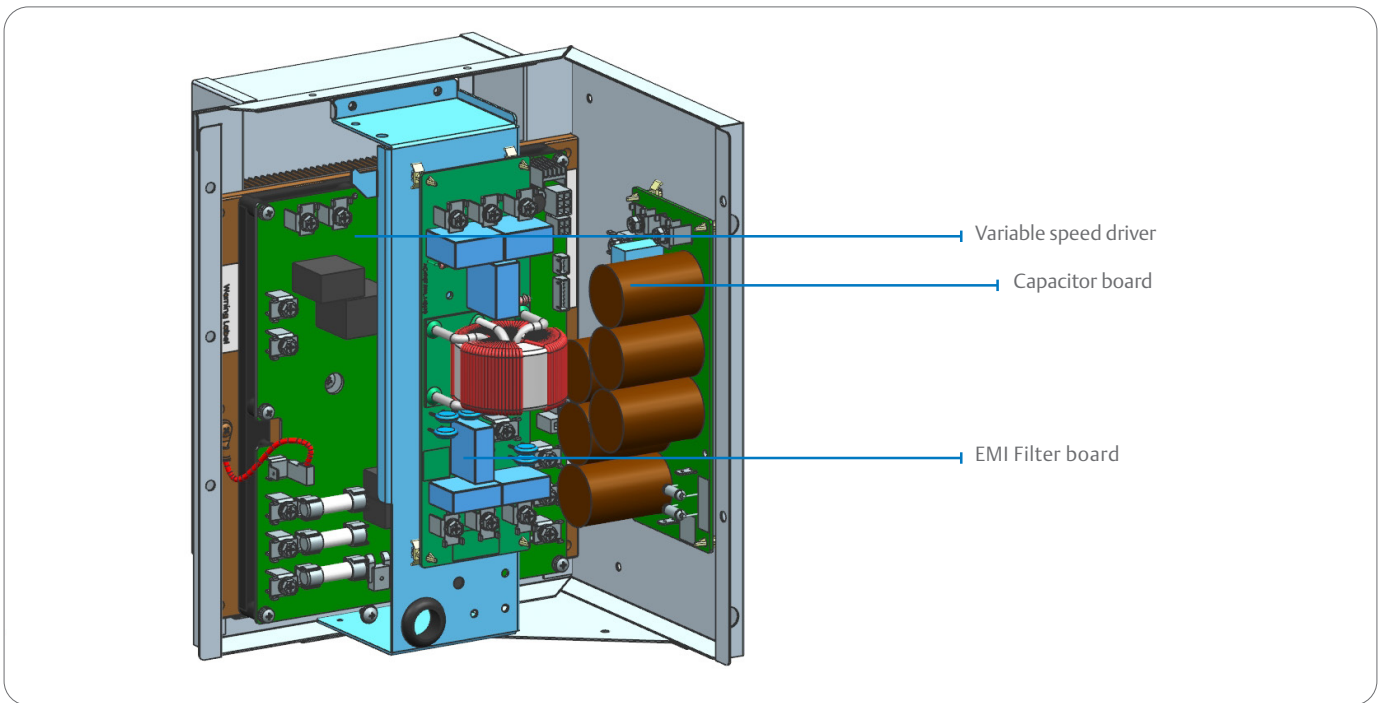

Figure 3. Drive assembly layout

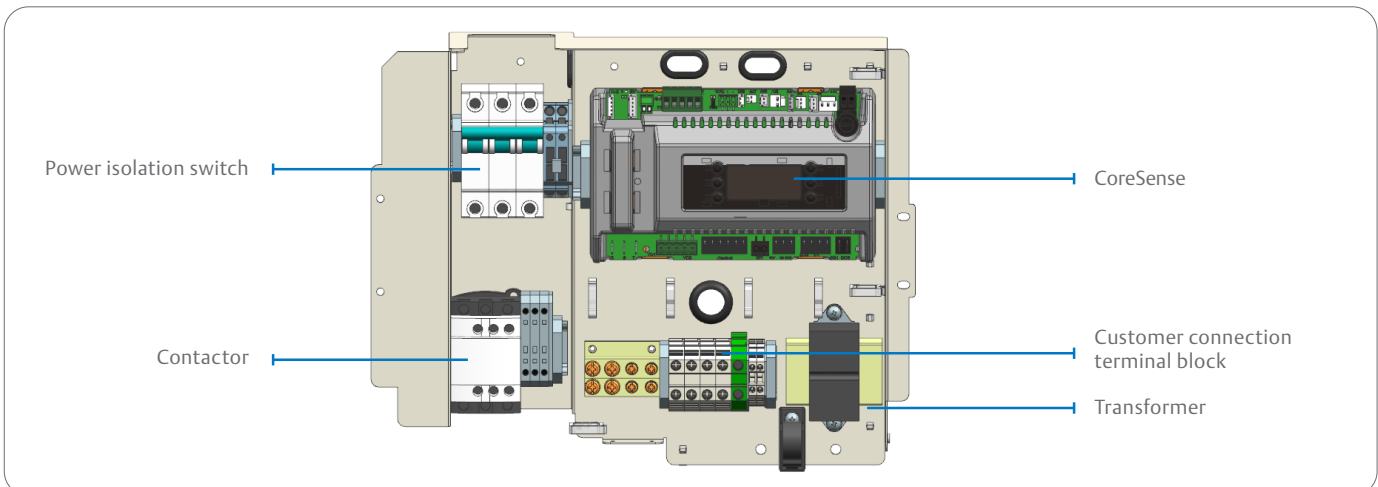

Figure 4. Control box layout

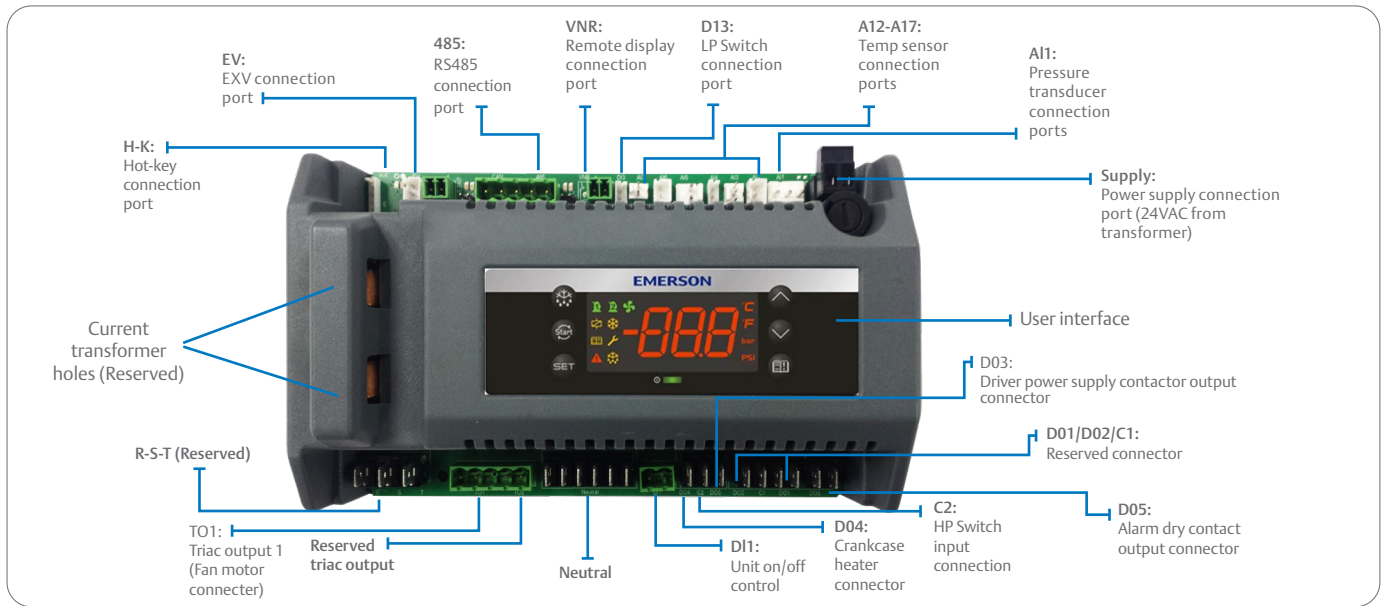

Figure 5. CoreSense controller

ZXV product specification

Qualified refrigerants and oils

Refrigerant	Oil
R410A/R404A	Emkarate RL 32 3 MAF / Mobil EAL Artic 22 CC

Oils are pre-charged in both compressor and oil separator.

Operating envelopes

Medium temperature

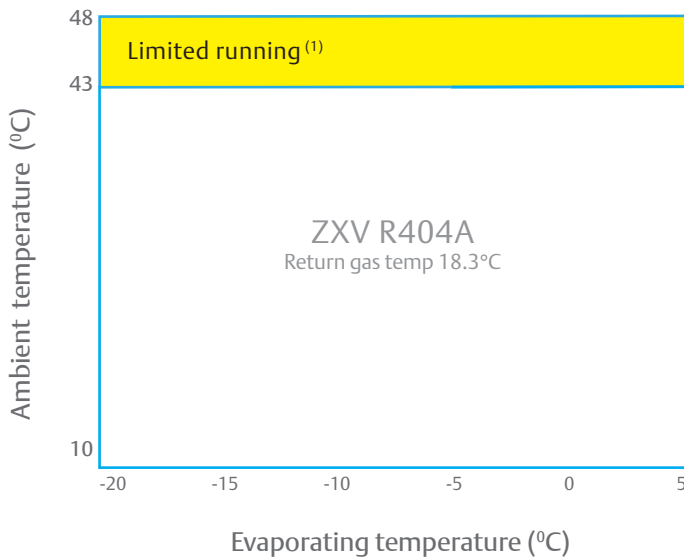

Note: ⁽¹⁾Continue run but with speed limitation

Low temperature

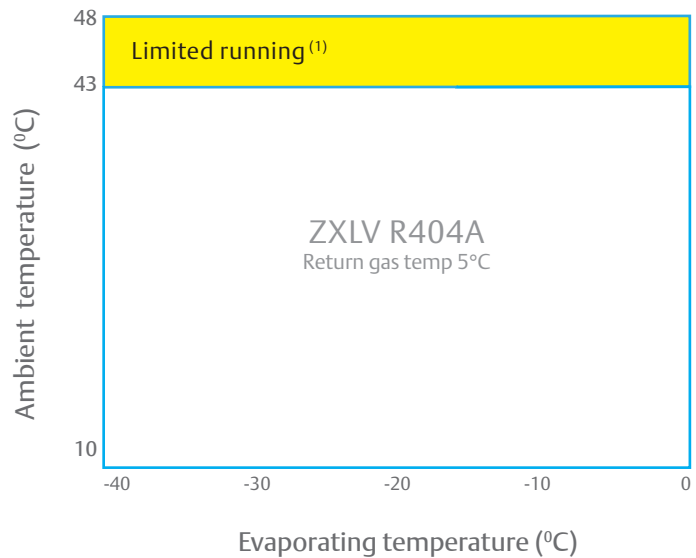

Note: ⁽¹⁾Continue run but with speed limitation

Performance data

R404A

Model		Ambient temperature (°C)	Evaporating temperature (°C)																	
			-20			-15			-10			-5			0			5		
			Min	Nor	Max	Min	Nor	Max	Min	Nor	Max	Min	Nor	Max	Min	Nor	Max	Min	Nor	Max
ZXV065BE	Capacity (kW)	27	1.81	4.66	5.94	2.23	5.46	6.85	2.70	6.47	8.23	3.20	7.49	9.39	3.76	8.32	10.11	4.32	8.78	10.06
		32	1.67	4.41	5.68	2.13	5.29	6.62	2.58	6.20	7.87	3.09	7.22	9.02	3.63	8.03	9.75	4.18	8.48	9.74
		38	1.57	4.16	5.31	1.93	4.97	6.36	2.41	5.89	7.48	2.98	6.88	8.63	3.48	7.48	9.09	3.99	7.76	8.89
		43	1.44	3.88	5.05	1.86	4.77	6.14	2.27	5.55	6.75	2.84	6.53	8.15	3.25	7.04	8.64	3.66	7.25	8.49
	Power (kW)	27	0.88	2.16	2.96	0.87	2.31	3.18	0.87	2.35	3.35	0.89	2.55	3.56	0.91	2.70	3.80	0.92	2.91	4.24
		32	0.98	2.38	3.24	0.99	2.54	3.44	0.99	2.59	3.64	0.99	2.81	3.95	1.02	3.00	4.28	1.04	3.25	4.85
		38	1.13	2.70	3.62	1.13	2.86	3.87	1.13	2.89	4.11	1.14	3.14	4.41	1.18	3.35	4.75	1.22	3.62	5.35
		43	1.24	3.03	4.04	1.26	3.19	4.30	1.29	3.24	4.57	1.29	3.50	4.86	1.31	3.66	5.15	1.33	3.91	5.71
ZXV085BE	Capacity (kW)	27	2.29	5.91	7.53	2.83	6.91	8.68	3.42	8.20	10.42	4.05	9.49	11.90	4.76	10.54	12.80	5.47	11.12	12.74
		32	2.11	5.59	7.20	2.70	6.70	8.38	3.27	7.85	9.97	3.91	9.15	11.43	4.60	10.17	12.35	5.29	10.74	12.34
		38	1.99	5.28	6.73	2.45	6.30	8.06	3.05	7.47	9.47	3.77	8.72	10.93	4.41	9.48	11.52	5.05	9.84	11.26
		43	1.83	4.92	6.40	2.35	6.04	7.78	2.88	7.03	8.55	3.60	8.27	10.32	4.12	8.92	10.94	4.64	9.19	10.75
	Power (kW)	27	1.12	2.83	3.99	1.10	3.02	4.29	1.10	3.08	4.52	1.13	3.33	4.80	1.15	3.53	5.12	1.17	3.79	5.71
		32	1.24	3.11	4.37	1.25	3.32	4.63	1.26	3.39	4.90	1.26	3.68	5.32	1.29	3.92	5.77	1.32	4.24	6.53
		38	1.43	3.53	4.88	1.43	3.74	5.22	1.43	3.78	5.54	1.45	4.10	5.94	1.50	4.37	6.40	1.55	4.73	7.20
		43	1.57	3.96	5.44	1.60	4.17	5.79	1.64	4.24	6.16	1.64	4.57	6.55	1.66	4.79	6.94	1.68	5.10	7.70
ZXV130BE	Capacity (kW)	27	3.35	7.66	11.17	3.95	9.02	13.16	4.29	10.48	14.97	5.05	11.78	16.82	5.68	13.25	18.93	6.45	15.06	21.51
		32	3.21	7.36	10.73	3.79	8.67	12.63	4.05	10.08	14.38	4.86	11.35	16.19	5.48	12.81	18.27	6.26	14.60	20.85
		38	2.98	7.08	9.93	3.52	8.37	11.74	3.82	9.67	13.41	4.55	10.93	15.16	5.16	12.41	17.20	5.93	13.84	19.77
		43	2.76	6.82	9.19	3.27	8.09	10.90	3.65	9.18	12.49	4.25	10.42	14.18	4.85	11.89	16.17	5.61	13.26	18.71
	Power (kW)	27	1.56	3.63	5.57	1.66	3.86	5.94	1.72	4.07	6.37	1.84	4.43	6.81	1.95	4.69	7.22	2.04	4.91	7.55
		32	1.68	3.95	5.92	1.78	4.13	6.36	1.83	4.43	6.86	1.99	4.79	7.37	2.12	5.10	7.84	2.22	5.35	8.24
		38	1.83	4.36	6.55	1.96	4.56	7.02	2.07	4.88	7.54	2.18	5.25	8.08	2.32	5.57	8.57	2.43	5.84	8.99
		43	2.02	4.76	7.20	2.14	4.96	7.64	2.20	5.29	8.13	2.33	5.62	8.64	2.46	5.92	9.11	2.56	6.22	9.50

Note:

- The rating condition is based on a return gas temperature of 18.3°C.
- Power includes condenser fan.
- Ambient 38°C and 43°C are typical design conditions for unit selection.

Performance data

R404A

Model	Ambient temp(°C)	Evaporating temperature (°C)																											
		-40			-35			-30			-25			-20			-15			-10			-5			0			
		Min	Nor	Max	Min	Nor	Max	Min	Nor	Max	Min	Nor	Max	Min	Nor	Max	Min	Nor	Max	Min	Nor	Max	Min	Nor	Max	Min	Nor	Max	
ZXLV030BE	Capacity (kW)	27	0.79	1.86	2.50	0.94	2.40	3.16	1.21	2.93	3.87	1.45	3.84	5.02	1.75	4.52	5.77	2.17	5.29	6.65	2.62	6.28	7.98	3.10	7.26	9.11	3.65	8.07	9.80
		32	0.73	1.82	2.38	0.92	2.30	3.01	1.15	2.86	3.70	1.39	3.69	4.82	1.62	4.28	5.51	2.07	5.13	6.42	2.50	6.01	7.63	2.99	7.00	8.75	3.52	7.78	9.46
		38	0.71	1.72	2.27	0.87	2.22	2.89	1.10	2.67	3.61	1.36	3.55	4.63	1.52	4.04	5.15	1.88	4.82	6.17	2.34	5.72	7.25	2.89	6.67	8.37	3.38	7.26	8.82
		43	0.66	1.65	2.17	0.84	2.11	2.74	1.06	2.60	3.39	1.29	3.35	4.38	1.40	3.77	4.90	1.80	4.63	5.96	2.21	5.38	6.55	2.76	6.33	7.90	3.16	6.83	8.38
	Power (kW)	27	0.84	1.79	2.33	0.85	1.90	2.46	0.86	2.00	2.33	0.86	2.05	2.40	0.89	2.17	2.98	0.87	2.32	3.20	0.87	2.37	3.37	0.90	2.56	3.58	0.91	2.71	3.82
		32	0.94	1.99	2.64	0.95	2.05	2.74	0.95	2.19	2.60	0.95	2.29	2.71	0.98	2.39	3.26	0.99	2.56	3.45	1.00	2.61	3.65	1.00	2.83	3.97	1.02	3.01	4.30
		38	1.08	2.28	3.10	1.09	2.36	3.18	1.09	2.53	3.00	1.07	2.59	3.07	1.13	2.71	3.64	1.13	2.88	3.89	1.13	2.91	4.13	1.15	3.16	4.43	1.19	3.36	4.77
		43	1.22	2.63	3.54	1.23	2.67	3.66	1.25	2.83	3.36	1.25	2.94	3.48	1.25	3.04	4.06	1.27	3.21	4.32	1.30	3.26	4.59	1.30	3.52	4.89	1.32	3.68	5.18
ZXLV040BE	Capacity (kW)	27	1.00	2.36	3.17	1.19	3.04	4.00	1.53	3.71	4.90	1.83	4.86	6.36	2.22	5.73	7.30	2.75	6.70	8.42	3.32	7.95	10.11	3.93	9.20	11.54	4.62	10.22	12.42
		32	0.92	2.31	3.02	1.16	2.91	3.81	1.46	3.63	4.69	1.76	4.68	6.11	2.05	5.42	6.98	2.62	6.49	8.13	3.17	7.61	9.67	3.79	8.87	11.09	4.46	9.86	11.98
		38	0.90	2.18	2.88	1.10	2.82	3.67	1.39	3.38	4.58	1.72	4.50	5.86	1.93	5.12	6.53	2.38	6.11	7.82	2.96	7.24	9.19	3.66	8.45	10.60	4.28	9.20	11.17
		43	0.83	2.09	2.75	1.07	2.67	3.47	1.34	3.30	4.30	1.63	4.24	5.55	1.78	4.77	6.21	2.28	5.86	7.55	2.79	6.82	8.29	3.49	8.02	10.01	4.00	8.65	10.61
	Power (kW)	27	1.07	2.34	3.15	1.08	2.48	3.32	1.09	2.62	3.15	1.09	2.67	3.24	1.13	2.84	4.01	1.11	3.03	4.31	1.11	3.09	4.54	1.14	3.35	4.82	1.16	3.54	5.15
		32	1.19	2.60	3.56	1.21	2.67	3.70	1.21	2.86	3.51	1.21	2.99	3.65	1.25	3.12	4.39	1.26	3.34	4.65	1.27	3.40	4.92	1.27	3.69	5.35	1.30	3.93	5.80
		38	1.37	2.98	4.18	1.39	3.08	4.29	1.38	3.30	4.04	1.36	3.38	4.14	1.44	3.54	4.90	1.44	3.76	5.25	1.44	3.80	5.57	1.46	4.12	5.97	1.51	4.39	6.43
		43	1.55	3.44	4.76	1.56	3.49	4.93	1.59	3.69	4.52	1.59	3.84	4.68	1.58	3.97	5.47	1.61	4.19	5.82	1.65	4.26	6.19	1.65	4.59	6.58	1.67	4.81	6.97
ZXLV050BE	Capacity (kW)	27	1.24	3.34	4.53	1.49	4.03	5.42	1.68	4.55	6.06	2.02	5.45	7.19	2.42	6.53	8.53	2.95	7.97	10.31	3.56	9.61	12.31	4.21	11.38	14.43	4.89	13.23	16.60
		32	1.17	3.17	4.22	1.41	3.81	5.12	1.63	4.40	5.85	1.96	5.28	6.96	2.37	6.39	8.34	2.86	7.74	10.00	3.43	9.26	11.84	4.03	10.89	13.79	4.65	12.56	15.75
		38	1.13	3.05	4.01	1.31	3.53	4.74	1.52	4.10	5.45	1.84	4.98	6.55	2.23	6.04	7.87	2.70	7.30	9.42	3.22	8.71	11.12	3.77	10.19	12.89	4.33	11.70	14.64
		43	1.08	2.93	3.85	1.26	3.41	4.44	1.47	3.98	5.13	1.77	4.78	6.10	2.15	5.82	7.35	2.60	7.04	8.80	3.10	8.37	10.37	3.61	9.77	11.97	4.13	11.15	13.52
	Power (kW)	27	1.45	2.91	3.95	1.56	3.10	4.15	1.71	3.33	4.50	1.85	3.57	4.88	1.97	3.77	5.21	2.09	3.94	5.52	2.21	4.11	5.82	2.33	4.29	6.14	2.47	4.49	6.50
		32	1.57	3.15	4.21	1.70	3.37	4.49	1.87	3.65	4.78	2.02	3.89	5.32	2.15	4.11	5.68	2.28	4.30	6.02	2.41	4.50	6.37	2.56	4.71	6.75	2.72	4.96	7.18
		38	1.83	3.67	4.95	1.96	3.87	5.16	2.11	4.13	5.58	2.26	4.36	5.96	2.39	4.57	6.32	2.53	4.77	6.68	2.68	4.99	7.07	2.84	5.23	7.49	3.03	5.51	7.99
		43	2.07	4.16	5.49	2.20	4.34	5.71	2.34	4.57	6.09	2.47	4.77	6.44	2.60	4.96	6.78	2.73	5.16	7.13	2.88	5.37	7.51	3.05	5.62	7.95	3.25	5.91	8.47

Note:

- The rating condition is based on a return gas temperature of 5°C.
- Power includes condenser fan.
- Ambient 38°C and 43°C are typical design conditions for unit selection.

Technical data

Medium temperature

Family				ZXV					
Model name				ZXV065BE	ZXV085BE	ZXV130BE			
Refrigerant				R404A, R448A					
Evaporating temperature range				°C					
Ambient range				°C					
Unit	Performance (R404A)	Maximum Capacity	-10°C ET/40°C AT/18°C RGT	kW	6.5	8.5	13.0		
		Nominal Capacity	-10°C ET/32°C AT/18°C RGT	kW	6.1	7.9	10.0		
		Nominal COP		W/W	2.44	2.32	2.28		
		Nominal Speed		RPM	4500 RPM	4500 RPM	4500 RPM		
		RLA (Rated load amps)		A	4.5	6.2	8.0		
		MOC (Max. Operating Current)		A	10.4	14.0	16.0		
	Sound	Sound Pressure Level @ 1m ¹		At Part Load	dB(A)	52-58	52-58	55-59	
		Sound Pressure Level @ 1m ¹	At Full Load	dB(A)	61	61	63.0		
Compressor				Model Name	ZBW030DE-4X9	ZBW038DE-4X9	ZBW050SE-4X9		
				Max Input Ampere	Amp	15	22	27	
				Oil Type	Amp	POE	POE	POE	
				Oil Charge Volumn	Liters	1.63	1.63	1.60	
				Speed Range	RPM	1800 - 6000	1800 - 6000	1800 - 6000	
Fan Motor	For 4XD Model	Number of Fan			1	1	2		
		Diameter		mm	450	450	450		
		Max Speed		RPM	830	830	830		
		Max Flow	Total	m ³ /h	2922	2922	5910		
		Max Fan Motor Power	Input	W	116	116	246		
	For 4XK Model	Number of Fan			1	1	2		
		Diameter		mm	450	450	450		
		Max Speed		RPM	933	933	933		
		Max Flow	Total	m ³ /h	3483	3483	6966		
		Max Fan Motor Power	Input	W	145	145	290		
Others				Oil Seperator	Volume	Liters	0.5	0.5	0.5
				Receiver Volumn		kg	4.3	4.3	6.3
				Pipes	Suction OD	Inch	3/4	3/4	7/8
					Liquid OD	Inch	1/2	1/2	1/2
				Dimension	W X H X D	mm	1029 x 424 x 840	1029 x 424 x 840	1029 x 424 x 1242
				Weight	Net	kg	101	104	136
					Gross	kg	139	139	180

Note: ¹ Preliminary data

Low temperature

Family				ZXLV					
Model name				ZXLV030BE	ZXLV040BE	ZXLV050BE			
Refrigerant				R404A, R448A					
Evaporating temperature range				°C					
Ambient range				°C					
Unit	Performance (R404A)	Maximum Capacity	-32°C ET/40°C AT/5°C RGT	kW	3.20	4.10	5.04		
		Nominal Capacity	-32°C ET/32°C AT/5°C RGT	kW	2.64	3.34	4.16		
		Nominal COP		W/W	1.24	1.20	1.18		
		Nominal Speed		RPM	4500 RPM	4500 RPM	4500 RPM		
		RLA (Rated load amps)			3.9	5.0	6.3		
		MOC (Max. Operating Current)		A	9.4	12.6	15.3		
	Sound	Sound Pressure Level @ 1m ¹		At Part Load	dB(A)	52-58	52-58	55-59	
		Sound Pressure Level @ 1m ¹	At Full Load	dB(A)	61	61	63.0		
Compressor				Model Name	ZFW030DE-4X9	ZFW038DE-4X9	ZFW050SE-4X9		
				Max Input Ampere	Amp	15	22	27	
				Oil Type	Amp	POE	POE	POE	
				Oil Charge Volumn	Liters	1.63	1.63	1.60	
				Speed Range	RPM	1800 - 6000	1800 - 6000	1800 - 6000	
Fan Motor	For 4XD Model	Number of Fan			1	1	2		
		Diameter		mm	450	450	450		
		Max Speed		RPM	830	830	830		
		Max Flow	Total	m ³ /h	2922	2922	5910		
		Max Fan Motor Power	Input	W	116	116	246		
	For 4XK Model	Number of Fan			1	1	2		
		Diameter		mm	450	450	450		
		Max Speed		RPM	933	933	933		
		Max Flow	Total	m ³ /h	3483	3483	6966		
		Max Fan Motor Power	Input	W	145	145	290		
Others				Oil Seperator	Volume	Liters	0.5	0.5	0.5
				Receiver Volumn		kg	4.3	4.3	6.3
				Pipes	Suction OD	Inch	3/4	3/4	7/8
					Liquid OD	Inch	1/2	1/2	1/2
				Dimension	W X H X D	mm	1029 x 424 x 840	1029 x 424 x 840	1029 x 424 x 1242
				Weight	Net	kg	101	104	136
					Gross	kg	139	139	180

Note: ¹ Preliminary data

CoreSense controller



LED descriptions





LED	Status	Description
	ON	Compressor1 is running
	Flashing	Compressor1 is ready to start
	ON	Reserved
	Flashing	Reserved
	ON	Condensing fan is running
	ON	Reserved
	ON	Display with °C
	Flashing	Programmable mode

LED	Status	Description
	ON	Browsing the service menu
	Flashing	Browsing the fast access menu
	ON	A new alarm happened
	Flashing	Browsing the alarm menu
	ON	An alarm is occurring
	ON	Reserved
	-	Reserved

Keyboard descriptions - single button

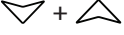

SET	Set	Display target set point; In programming mode, select a parameter or confirm an operation.
	Reset	Hold for 5 seconds to reset any lockouts if the current state of the controller allows for it to be reset.
	Up	Enter the fast access menu; In programming mode, browse the parameter codes or increases the displayed value.
	Down	In programming mode it browses the parameter codes or decreases the displayed value.
	Service	Enter the service and alarm menu.
	Defrost	Hold for 3 seconds to start a manual defrost or terminate an active defrost. (Not available at the moment).

Keyboard descriptions - combined buttons

	Press and hold for about 3 seconds to lock (Pon) or unlock (PoF) the keyboard.
SET + 	Pressed together to exit programming mode or menu; under rtC and Par, this combination allows the user to go back to previous level.
SET + 	Pressed together for 3 seconds allows access to first level of programming mode.
SET + 	Pressed together for 3 seconds allows access to EXV manual setting.

Controller initialization message

When the unit is initially powered on, the controller will display.







Step	Action	Phenomenon and description
1	Power on controller	All LEDs will light up for 3 seconds.
2		Firmware version will be displayed for 3 seconds.
3		Parameter setting file (bin file number) identifier will be displayed for 3 seconds.
4		Normal display (actual suction temperature will be displayed on ZXV/ZXD unit, condensing temperature will be displayed on ZX/ZXL/ZXB unit)

Bin files number range









Bin number range	Family
701-799	ZXV, ZXLV
850	ZXV service
851	ZXLV service

After installation and initial power on, it is critical to double check the parameters below.



RTC (real time clock) setting

Step	Action	Phenomenon and description
1	Press " SET " + " 	Enter menu to select "PAr" (parameter) or "rtC"
2	Press "  or " 	Select "rtC"
3	Press " SET "	"n01", minute "n02", hour "n03", day "n04", month "n05", year (last two digits)
4	Press " SET "	Display actual value
5	Press "  or " 	Modify the value
6	Press " SET "	Press "SET" : the value will flash for 3 seconds, then move to the next value
7	Press " SET " + " 	Exit to "rtC"
8	Press " SET " + " 	Exit to main menu (or wait for 120 seconds and exit automatically)









Refrigerants

Step	Action	Phenomenon and description
1	Press " SET " + " 	Enter menu to select "PAr" (parameter) or "rtC"
2	Press "  or " 	Select "PAr (parameter)"
3	Press " SET "	Confirm selection
4	Press "  or " 	Browse to parameter C07
5	Press " SET "	Confirm selection
6	Press "  or " 	Select refrigerant to be used
7	Press " SET "	The number will flash for 3 seconds and confirm the refrigerant selection
8	Press " SET " + " 	Exit (or exit automatically after waiting for 120 seconds)



Evaporating temperature setting

Step	Action	Phenomenon and description
1	Press " SET " > 3 seconds	Press " SET " button for more than 3 seconds, the measurement units (°C) will flash together.
2	Press "  or " 	Modify the number for target evaporating temperature
3	Press " SET "	Press " SET " to confirm, the number will flash for 2 seconds (or wait for about 10 seconds to confirm)





Pr1 parameter (1st level) browse and modification

Step	Action	Phenomenon and description
1	Press "SET" + 	Enter menu to select "PAr" (parameter) or "rtC"
2	Press "  or " 	Select "PAr (parameter)"
3	Press "SET"	Confirm, select, and browse Pr1 parameters
4	Press "  or " 	Browse Pr1 parameters
5	Press "SET"	View the actual number of the Pr1 parameters
6	Press "  or " 	Modify the actual number of the Pr1 parameters
7	Press "SET"	Press"SET" : The number will flash for 3 seconds and confirm the modification; Will go to the next Pr1 parameter
8	Press "SET" + 	Exit (or exit automatically after waiting for 120 seconds)













Quick access menu browse - sensors status and actual values

Step	Action	Phenomenon and description
1	Press " 	Enter quick access menu, will display "P1P" (Press "Up" or "Down" to view other sensors)
2	Press "SET"	View the actual value of "P1P"
3	Press "SET"	Change to next sensor code
4	Press "SET" + " 	Exit (or exit automatically after waiting for 60 seconds)
		<ul style="list-style-type: none"> • P1P : Pressure value of suction (only in ZXD & ZXV) • P2t : Temperature value of condenser mid coil • P2P : Pressure value of discharge (not used) • P3t : Temperature value of DLT (discharge line temperature) • P4t : Temperature value of VIT (vapor inlet temperature) (only in ZXL, ZXV, ZXB) • P5t : Temperature value of VOT (vapor outlet temperature) (only in ZXL, ZXV, ZXB) • P6t : Temperature value of ambient temperature • P7t : Not used • SH : Value of superheat when control logic control vapour injection superheating, or display DLT values when control logic is control DLT • oPP : Percentage of step EVI valve opening • LLS : Status of the liquid line solenoid (not used) • Std : Value of the condenser temperature setting • Aoo : Percentage of condensing fan driver output • dSo : Percentage of the PWM output driving the valve of the digital scroll compressor (not used) • inU : Compressor speed percentage of controller sent to driver • inS : Compressor speed percentage of the reading values from driver • iUt : Driver input voltage values (only valid in ZXV with EV2 drive) • iPr : Driver input power values (only valid in ZXV with EV2 drive) • Lt : Minimum room temperature (not used) • Ht : Maximum room temperature (not used) • tU1 : Voltage 1 (R-S terminal) values (not used) • tU2 : Voltage 2 (S-T terminal) values (not used) • tU3 : Voltage 3 (T-R terminal) values (not used) • tA1 : Current 1 (upper transformer) values (not used) • tA2 : Current 2 (lower transformer) values (not used) • SLA: Quantity of low side controller connected with outdoor unit. • HM : Time Menu (hour & minute)
		<p>Sensor code and values descriptions ("nP", "noP", or "nA" mean that the sensor does not exist; "Err" means that the sensor fails, out of range, disconnected, or does not configure correctly)</p>

Access alarm code (maximum of 50 record)

Step	Action	Phenomenon and description
1	Press "  "	Display "SEC"
2	Press " SET "	Display "A01"
3	Press "  "	Display alarm code in "A01"
4	Press "  "	Display "A02"
5	Press "  "	Display alarm code in "A02"
6	...	
7	Press " SET " + "  "	Exit (or exit automatically after waiting for 15 seconds)

Exact timing of the alarm

Step	Action	Phenomenon and description
1	Press "  "	Display "SEC"
2	Press " SET "	Display "A01"
3	Press "  "	Display alarm code in "A01"
4	Press " SET "	Display "Hr"
5	Press "  "	Display the alarm exact timing: hour
6	Press "  "	Display "Min"
7	Press "  "	Display the alarm exact timing: minute
8	Press "  "	Display "Day"
9	Press "  "	Display the alarm exact timing: day
10	Press "  "	Display "Mon"
11	Press "  "	Display the alarm exact timing: month
12	Press "  "	Display "yEA"
13	Press "  "	Display the alarm exact timing: year
14	Press " SET " + "  "	Exit (or exit automatically after waiting for 15 seconds)

Upload the program from the controller to hot-key

Step	Action	Phenomenon and description
1	Inert Hot-Key when the controller is ON	
2	Press "  "	the "uPL" message appears followed by a flashing "End" label (Note: if display "Err", it means it fails to upload program to Hot-Key. Please restart the process.)
3	Press " SET "	"End" will stop flashing
4	Turn-off the controller and remove Hot-Key	
5	Turn-on the controller	

Download the program from hot-key to controller

Step	Action	Phenomenon and description
1	Turn-off the controller	
2	Insert hot-key	
3	Turn-on the controller	The “doL” message will blink followed a by a flashing “End” label (Note: if display “Err”, it means it fails to download program to the controller. Please restart the process.)
4		Controller will restart working with the new parameters after 10 seconds
5	Remove hot-key	

Network wiring

Dixell XWEB300D serial address

- Connect to the ModBUS network using cable with 2 or 3 shielded wires, minimum section 0.5mm² (e.g. BELDEN8772)
- Do not connect shield to ground.
- Do not connect the “Gnd” terminal.
- Remember to draw a map of the line. This will help you to find an error if something is wrong.
- RS485 devices are polarity sensitive.



Figure 5. Correct network wiring

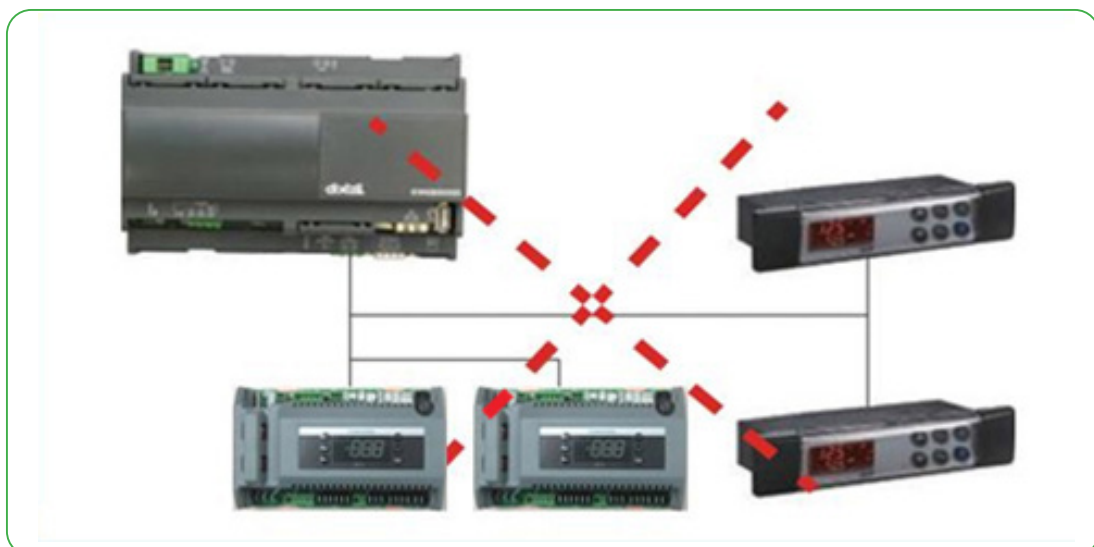

Figure 6 . Incorrect network wiring

Termination resistor for XWEB300D

If XWEB300D is placed at the beginning or at the end of the line, please install its termination resistor by adding a jumper in position 2 (JMP2 on the back side of the unit). Do not add the jumper if XWEB300D is placed in the middle of the RS485 line.

ZX CDU connected to XWEB300D

ZX CDU connected to the Dixell XWEB300D with the Intelligent Store solution module using RS485 ModBUS.

Connect the ZX CDU to the ModBUS network as shown in Figure 7. Connect the network cable to the three-terminal connector on the XWEB300D port that has been configured as ModBUS port (COM 12, 13, 14).

Connect port "13" of XWEB300D to port "D0485 +" of CoreSense™ and port "12" of XWEB300D to port "D1485 -" of CoreSense for RS485 communication.

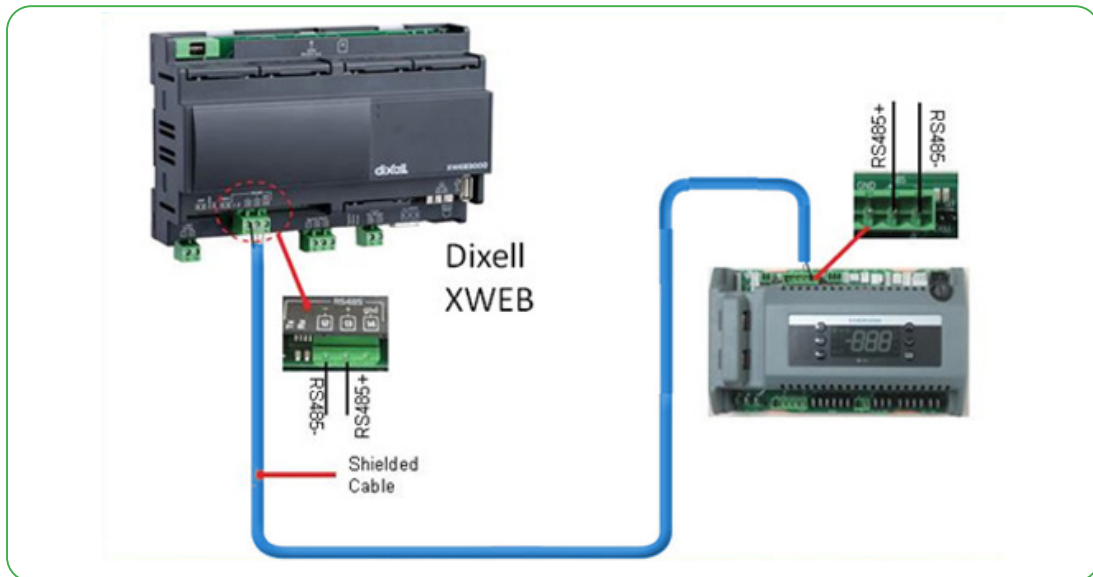

Figure 7. XWEB300D Connected to the Intelligent Store solution module

Dixell XWEB300D configuration

XWEB300D is compatible with ZX CDU if XWEB has the library of ZX controller CoreSense.

Login into XWEB

- Go to Information → Information
- If this is not present, follow the steps below.

Open Dixell website <http://www.dixell.com/xweb300d-xweb500-xweb500d/eng/>, then login (registration required)

- Go to Support → System sw update → XWEB300D XWEB500 XWEB500D
- Download the upgrade package with your web-browser, login into XWEB
- Go to Information → System Update menu

Provide the XW5 patch file

Once file has been selected wait until the upgrade procedure ends (XWEB reboots)

Verify the installation ended successfully by checking into the menu

- Go to Information → Information for string

Log in again and set up the ZX CDU

- Go to Configuration → Devices drop-down menu
- Go to Actions → New
- Enter device name in the Name field (e.g. ZX CDU)
- Select "XCM25D" in the Model field
- Enter the ModBUS address in the RS 485 address field
 - Refer to setting of parameter "t01" in pr2 level in CoreSense™ (default setting is "1")
- Click New

Communication with low side

There will be two parts, condensing unit and showcases or cold rooms. The condensing unit is in outdoor side, showcase/cold room is in indoor side. The connection between condensing unit & showcases/cold rooms are RS485 wires.

The condensing unit controller works as MASTER mode, the showcases/cold rooms controllers work as SLAVE mode. Condensing unit controller MASTER port can connect maximum 11 SLAVE controllers including compressor drive.

The communication address setting range of showcase/cold room controller is "1-15". That means condensing unit controller will search the showcase/cold room controllers from address 1 to 15, will not search the address above 15.

The structure of above description is shown as below.

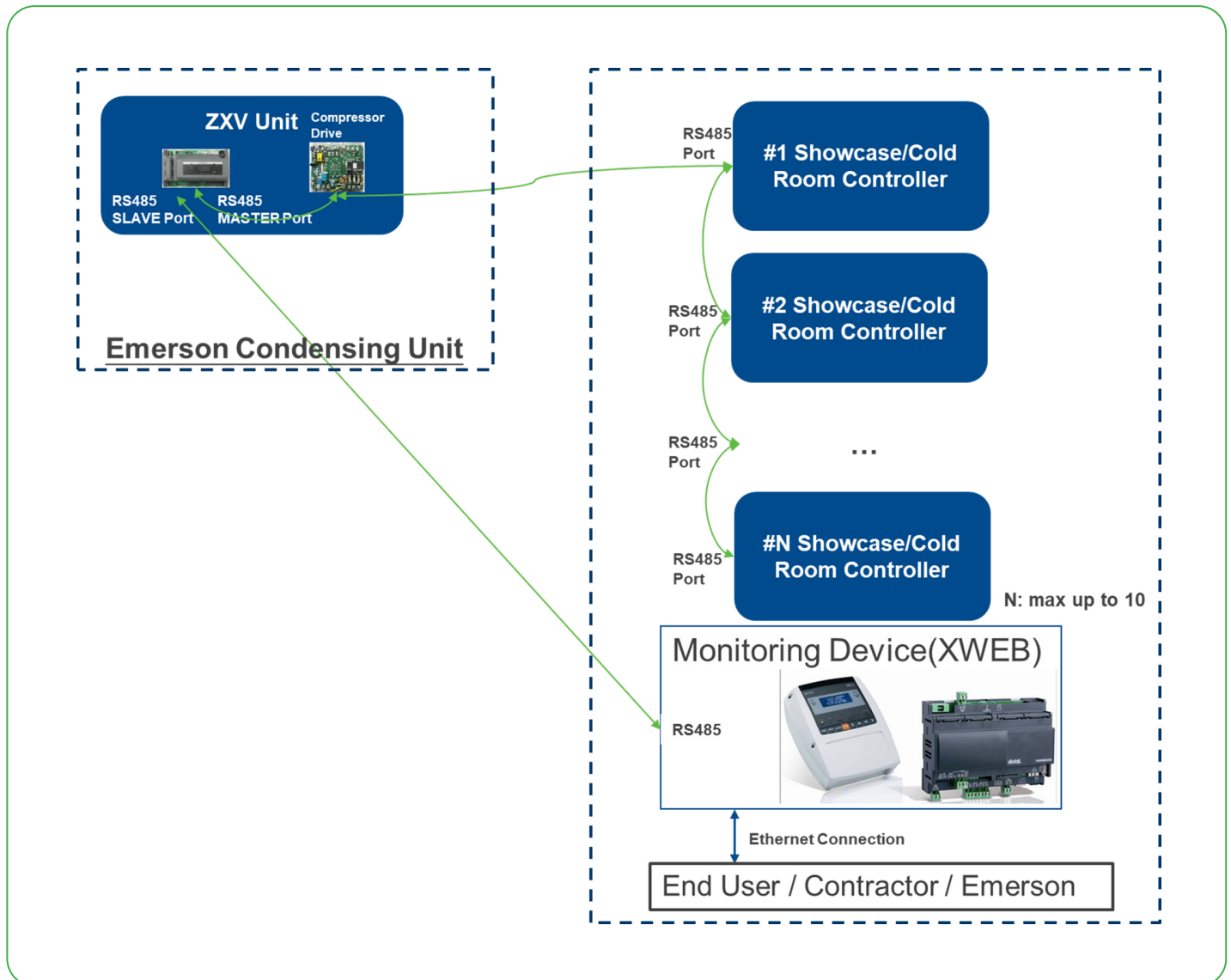

Showcase/cold room controllers supported list

Device Name	NOTES (Firmware Version Information)
XR60	(V1.0)
XR70	(V1.0)
XR75	(V2.6)
XR77	(V2.6)
XM678D	(V2.8)
XM679K	(V4.2)
XR35CX*	(V2.6)
XM678D*	(V5.4)

* XR35CX V2.6 & XM678D V5.4 will be supported soon.

Wiring connection between condensing unit & showcase/cold room controllers

There will be two parts, condensing unit and showcases or cold rooms. The condensing unit is in outdoor side, showcase/cold room is in indoor side. The connection between condensing unit & showcases/cold rooms are RS485 wires.

The condensing unit controller works as MASTER mode, the showcases/cold rooms controllers work as SLAVE mode. Condensing unit controller MASTER port can connect maximum 11 SLAVE controllers including compressor drive.

The communication address setting range of showcase/cold room controller is “1-15”. That means condensing unit controller will search the showcase/cold room controllers from address 1 to 15, will not search the address above 15.

The structure of above description is shown as below.

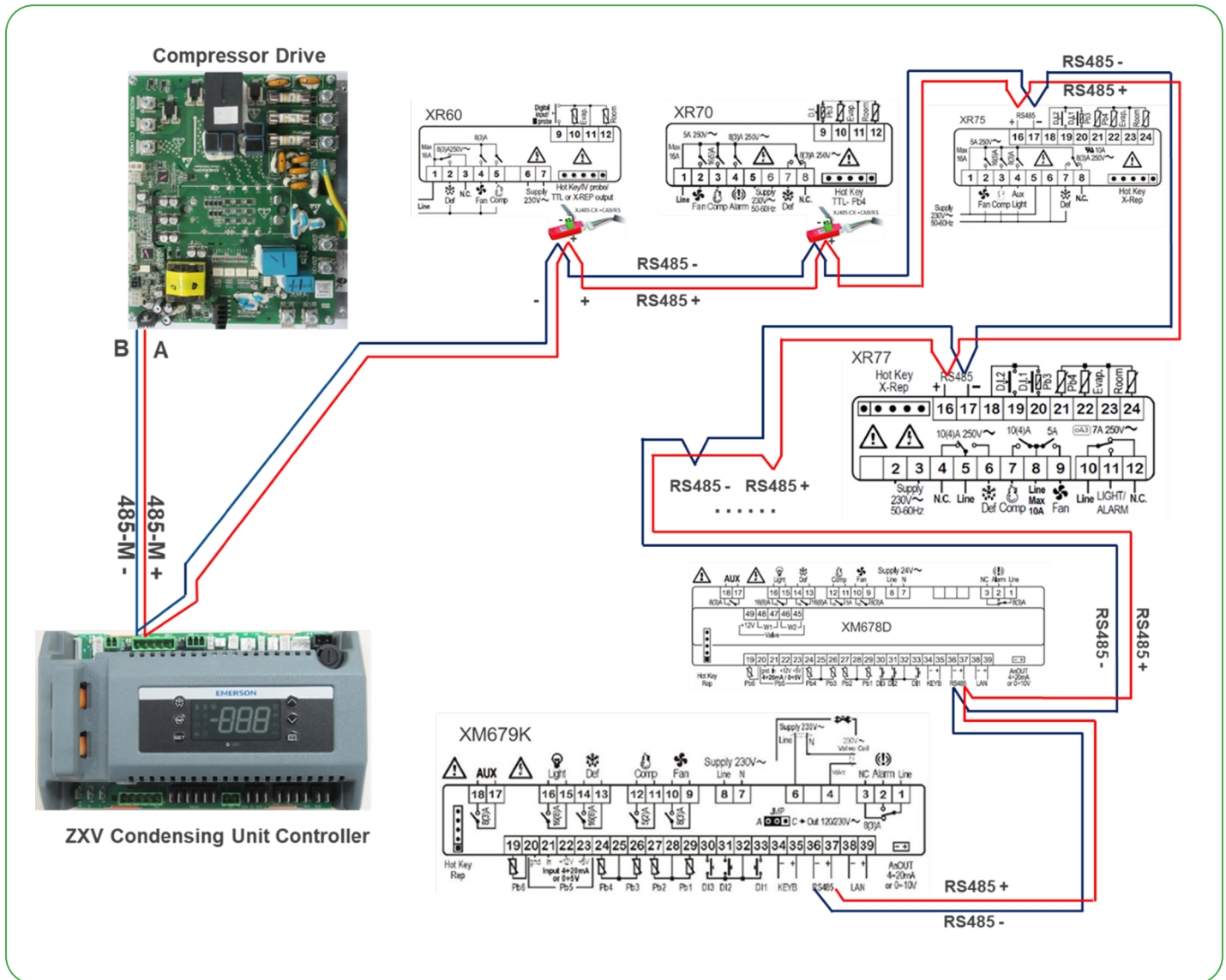

Notes:

- For XR60, XR70 controllers, need XJ485CX converter to connect to “Hot Key TTL” port to support RS485 communication wiring.
- The values of “SLA” in controller quick menu can show the connected quantity of showcase/cold room controllers.

Installation

Copeland™ ZX condensing units are delivered with a holding charge of neutral gas. The condensing unit should be located in a place protected from excess amounts of dirt, sand, dust, plastic bags, leaves or paper debris which can cover and block the flow of air over the condenser (fins). The unit must be installed without restricting the airflow. A clogged condenser will result in increased condensing temperature, reducing the cooling capacity, causing the high-pressure switch to trip. Clean the condenser fins on a regular basis.

Condensing unit handling

Transport and storage

Move ZXV unit only with appropriate mechanical or handling equipment according to weight. Keep in the upright position. Do not stack single boxes on top of each other without pallet in any case. Keep the packaging dry at all times.

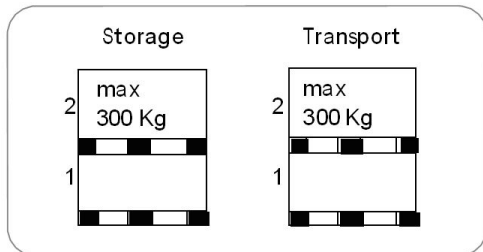

Electrical connection

Power supply

The ZXV condensing unit electrical connection to the power supply must be made by qualified technicians, who should refer to the electrical diagrams located inside the electric connection panel. The units are designed for below power supply at $\pm 10\%$ voltage tolerance. The circuit breaker must be switched off before opening the front panel.

Electrical wiring

Before commissioning, ensure that neutral “N” wire is connected to the terminal block (“N” furthest to the right). After proper connection of the ZXV condensing unit, the control LED on the power board and control board will light up. For more details, see wiring diagrams. Customers’ wire size needs to be selected to allow for the maximum operation current of each unit.

Caution! Unit should be powered on at all times except during service. Failure to do so can result in component failure.

Refrigeration piping installation

All interconnecting pipes should be of refrigeration grade, clean, dehydrated and must remain capped at both ends until installation. Even during installation, if the system is left for any reasonable period of time (say two hours), pipes should be re-capped to prevent moisture and contaminants from entering the system.

Do not assume that the service connection sizes on the unit (at the service valves) are the correct size to run your interconnecting refrigeration pipes. The service valve sizes have been selected for convenience of installation and in some cases (larger units) these may be considered too small. However for the very short pipe run within our units, these service connection sizes are adequate. All interconnecting pipes should be sized to satisfy the duty required.

Usually the suction line is insulated, but the liquid line is not. However the liquid line can pick up additional heat from the ambient and adversely affect the sub-cooling desirable for the liquid refrigerant before it enters the expansion valve.

The pipe should be sized to ensure optimum performance and good oil return. The sizing must also take into account the full capacity range through which this particular unit will need to operate.

Pipe runs should be kept as short as possible, using the minimum number of directional changes. Use large radius bends and avoid trapping of oil and refrigerant. This is particularly important for the suction line. The suction line should ideally slope gently towards the unit. Recommendation slope is 1/200~1/250. P traps, double risers and reduced pipe diameters may be required for suction lines where long vertical risers cannot be avoided. All pipes should be adequately supported to prevent sagging which can create oil traps. The recommended pipe clamp support distance is shown in the table.

Tube size	Max distance between 2 clamp support
12.7mm (1/2 inch)	1.20 m
16.0mm (5/8 inch)	1.50 m
22.0mm (7/8 inch)	1.85 m
28.5mm (1 1/8 inch)	2.20 m

Liquid line insulation

ZXV liquid line should be insulated with a 10mm insulation thickness. Temperature could be lower than 0°C.

Brazing recommendations

Maintain a flow of oxygen-free nitrogen through the system at a very low pressure during brazing. Nitrogen displaces the air and prevents the formation of copper oxides in the system. If copper oxidization is allowed to form, the copper oxide material can later be swept through the system and block screens such as those protecting capillary tubes, thermal expansion valves, and accumulator oil return holes. This minimizes any entry of contaminants and moisture.

- Remove the liquid line connection cap.
- Then remove the suction connection cap.
- Open both valves midway. Care should be taken to avoid the holding charge from releasing too quickly.
- Be sure tube fitting inner diameter and tube outer diameter are clean prior to assembly.
- Since both tubes are extended from the condensing unit housing, we recommend insulating the housing by using a wet cloth on the copper tubing.
- Recommended brazing materials: a copper / phosphorous or copper / phosphorous / silver alloy rod should be used for joining copper to copper whereas to join dissimilar or ferric metals, use a silver alloy rod, either flux coated or with a separate.
- Use a double tip torch.

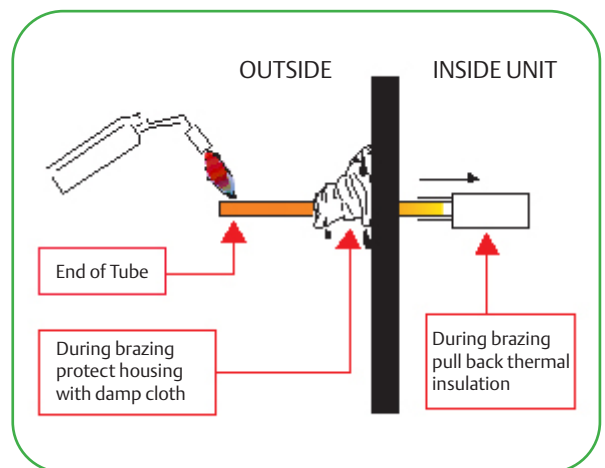

Location and fixing

The unit should always be installed in a location that ensures clean air flow. It is recommended that a clearance of 300 mm from the wall (or the next unit) be maintained from the unit's left and rear panels whereas a clearance of 2 meters must be maintained from the unit's right, top and front panels (seen facing the front of the unit). Both service access and airflow have been considered in making these recommendations. Where multiple units are to be installed in the same location, the contractor needs to consider each individual case carefully. There can be many variations of unit quantities and available space and it is not the intention of this manual to go over these. Ideally, the unit should be mounted on a solid concrete slab with anti-vibration pads between unit feet and concrete. However the ZX condensing unit has also been designed for wall mounting on suitable brackets. Wall mounting brackets are not included. Another factor to consider in finding a good installation site is the direction of the prevailing wind. For example if the air leaving the condenser faces the prevailing wind, the air flow through the condenser can be impeded, causing high condensing temperatures ultimately resulting in reducing unit life. A baffle is a remedy for this situation.

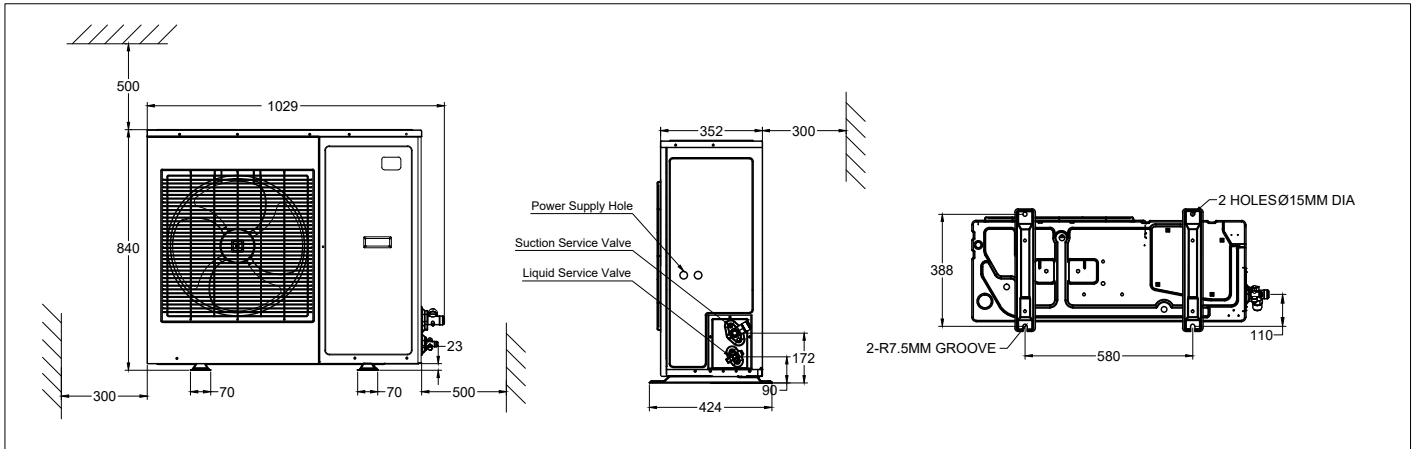

Fixing dimensions and distance - single fan unit

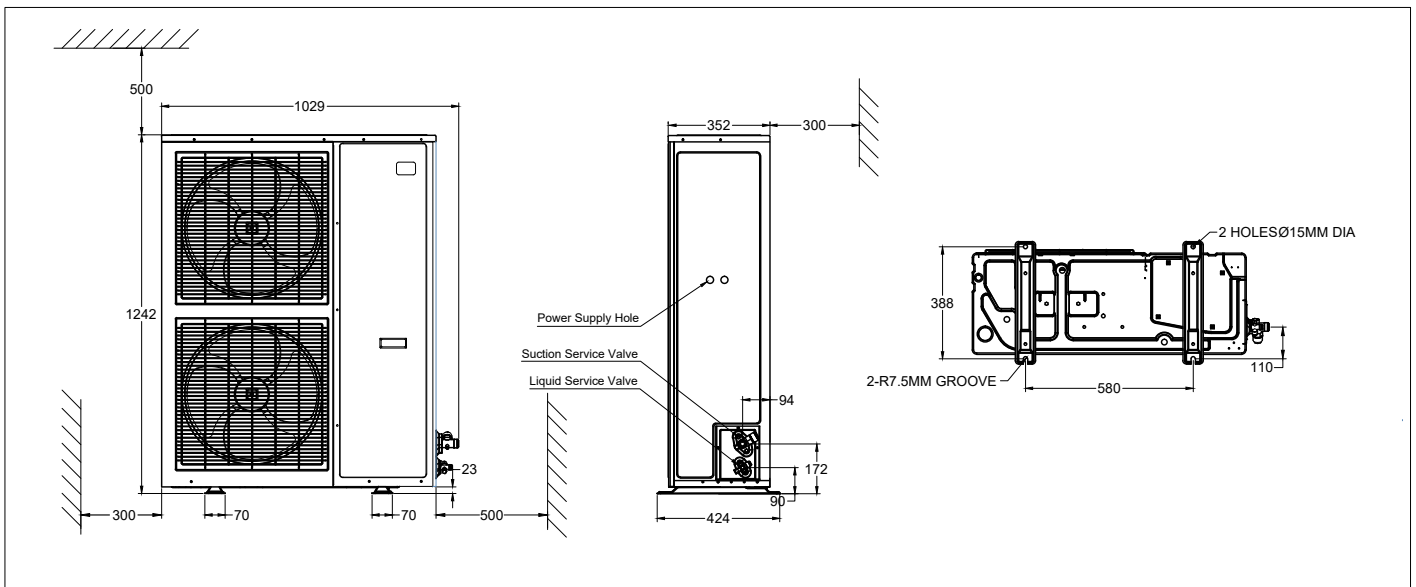

Fixing dimensions and distance - dual fan unit

Start up and operation

Before commissioning, ensure that all valves on the condensing unit are fully opened.

Vacuuming

The evacuation procedure is based upon achieving an actual system vacuum standard and is not time dependent. Before the installation is put into commission, it has to be evacuated with a vacuum pump. Proper evacuation reduces residual moisture to 50ppm. The installation of adequately sized access valves at the furthest point from the compressor in the suction and liquid lines is advisable. To achieve undisturbed operation, the compressor valves are closed and the system is evacuated down to 0.3 mbar / 0.225 Torr. Pressure must be measured using a vacuum pressure (Torr) gauge on the access valves and not on the vacuum pump; this serves to avoid incorrect measurements resulting from the pressure gradient along the connecting lines to the pump.

Charging procedure

Refrigerant charging procedure

The scroll compressor design requires system charging as quickly as possible with liquid refrigerant into the liquid line. This will avoid running the compressor under conditions where there is insufficient suction gas. Sufficient suction gas is needed to cool not only the motor but also the scrolls. Temperature builds up very quickly in the scrolls if this is not done. Do not charge vapor (gas) refrigerant into the ZX Scroll unit. The suction service valve must not be fully closed at any time while the compressor is running. Doing so would cause damage to the compressor in the same manner as explained above. This valve is provided for ease of connection and for the fitting of service gauges without removing the unit panel. It is recommended to charge the ZX unit with refrigerant via its service valves. It is also recommended to break the vacuum in the system with a partial charge of the refrigerant, before starting the system. For charge adjustment, it is recommended to check the liquid line sight glass just before the expansion valve.

Oil charging procedure

Emerson ZX condensing units are supplied only with nominal compressor oil charge. After commissioning, the oil level should be checked and topped up if necessary. The oil level should be approximately halfway up the sight glass (ZXL/ZXV/ ZXD units). Additional oil can be charged through the Schraeder valve on suction valve.

Scroll compressor rotation direction

Scroll compressors, like several other types of compressors, will only compress in one rotational direction. Comparing to normal 3-phase fixed compressors, ZXV unit compressor rotational direction is checked at the right direction in the plant. Customer power connection sequence does not change the compressor rotation direction.

Maximum compressor cycle

Maximum permitted starts per hour is 10.

Check before starting & during operation

Both valves should be fully opened on the liquid line, in order to prevent trapping liquid.

- Check that all valves are fully opened.
- After starting and operation conditions are stabilized, it is recommended to check the oil level in compressor(s) and see if there is a need to add oil to ensure sufficient oil level (halfway up the sight glass).

ZXV do's and don't

Do's	Don'ts
1. Unit should be grounded at all time	1. Don't connect power supply directly to the compressor at any time
2. Wait for at least 2 minutes after power disconnection to perform service work on the compressor drive	2. Don't touch the chokes. These become hot during operation.
3. Refrigerant charge connection size: ½" -20 UNF (Not 7/16" – 20 UNF)	3. Don't touch the condenser fins.
4. Pay special attention to refrigerant charge <ul style="list-style-type: none"> – Liquid line sight glass should be full all the time – Compressor suction superheat should be ~5 to 10K – Condensing temperature should be 8~ 10K larger than ambient temperature 	
5. Liquid pipe line should be insulated by insulation material (10 mm)	
6. Safe oil level is from ¼ to ¾ of the compressor oil sight glass	
7. After compressor replacement, check the rotation. If reverse rotation is observed, please change two connections at the compressor t-box. Changing at unit's power supply will not correct reverse rotation.	
8. With louvered fin, regular condenser cleaning is necessary to keep unit operating efficiently.	
9. Note that sound generated by the unit is not constant due to changes in compressor speed	
10. Parameter C16 (setC) /C17 (band) <ul style="list-style-type: none"> – C16 = -6 & C17 = 10 (Default) – C16 = -8 & C17 = 8 – C16 = -10 & C17 = 5 	

Alarm codes

Level	Descriptions
Warning	Unit (including compressor) is running but some data reach unsafe area; alarm dry-contact will not close; reset automatically
Alarm	Unit (including compressor) may run not with full functions; alarm dry-contact will not close; reset automatically
Lock	Unit (including compressor) stops working; alarm dry-contact will close; manual reset is needed

Alarm code	Description	Alarm type	Possible reason	Action	Reset
E01	Suction pressure probe failure alarm	Hardware error	Probe failure or out of range	No (ZXD/ZXV unit only)	Automatic reset when the probe restarts working
E02	Condensing temperature probe failure alarm	Hardware error	Probe failure or out of range	Function: fan speed control is disabled	Automatic reset when the probe restarts working
E03	Discharge temperature probe failure alarm	Hardware error	Probe failure or out of range	Function: discharge temperature protection is disabled	Automatic reset when the probe restarts working
E04	PHE vapor inlet temperature probe failure alarm	Hardware error	Probe failure or out of range	Function: PHE Superheat Control is disabled (ZXL/ZXB/ZXV unit only)	Automatic reset when the probe restarts working
E05	PHE vapor outlet temperature probe failure alarm	Hardware error	Probe failure or out of range	Function: PHE Superheat Control is disabled (ZXL/ZXB/ZXV unit only)	Automatic reset when the probe restarts working
E06	Ambient temperature probe failure alarm	Hardware error	Probe failure or out of range	Related functions are disabled	Automatic reset when the probe restarts working
E23	Over current alarm	Electrical error	Compressor current is larger than settings	The compressor will be tripped	Automatically with time delay
L23	Over current lock	Electrical error	Over current alarm happens frequently	The compressor will be tripped and the unit will be locked	Press "Start" >5 sec or manually power-off and power-on
E26	Low voltage alarm	Electrical error	Voltage is lower than settings; or voltage sensors do not work	The compressor will be tripped	Automatically with time delay
E27	Over voltage alarm	Electrical error	Voltage is higher than settings	The compressor will be tripped	Automatically with time delay
L35	Inverter lockout	LOCKOUT	Inverter with lockout errors	The compressor will be tripped and the unit will be locked	Press "Start" >5 sec or manually power-off and power-on
L38	Variable speed unit wrong parameter configuration	LOCKOUT	1. Driver with wrong configuration 2. Controller with wrong configuration	The compressor will be tripped and the unit will be locked	Automatically when driver and controller have the right configuration
L39	Communication lost between inverter & system controller	LOCKOUT	1. Poor connection between controller & driver 2. Controller/driver issue	The compressor will be tripped and the unit will be locked	Automatically when communication recover
E40	High pressure switch alarm	Refrigeration system error	High pressure switch is open	The compressor will be tripped	Automatically when HP switch closes

Alarm code	Description	Alarm type	Possible reason	Action	Reset
L40	High pressure switch lock	Refrigeration system error	High pressure switch alarm happens frequently	The compressor will be tripped and the unit will be locked	Press "Start" >5 sec or manually power-off and power-on
E41	Low pressure switch alarm	Refrigeration system error	Low pressure switch is open	The compressor will be tripped	Automatically when LP switch closes and time delay
E44	High discharge temperature alarm	Refrigeration system error	Discharge temperature is higher than settings	The compressor will be tripped	Automatically when discharge temperature is lower than settings and time delay
E46	High condensing temperature alarm	Refrigeration system error	Condensing temperature is higher than settings	No	Automatically when condensing temperature is lower than settings
E47	EXV Full-open warning	Refrigeration system error	Less refrigerant charge or leakage	No	Automatically when EXV is not at full-open
E48	Less injection warning	Refrigeration system error	Less refrigerant charge or leakage	No	Automatically when PHE super heat is smaller than settings
E50	High side liquid back warning	Refrigeration system error	Suction liquid back or injection too much	No	Automatically when the difference of discharge temperature and condensing temperature is higher than settings and time delay
E67	Communication lost between outdoor unit and showcase controllers	Warning	1. Communication cables poor connection 2. Showcase controllers didn't powered on or have communication part issues 3. Outdoor unit controller has communication part issue	NO	Automatically when communication recovered
E80	RTC warning	Misc. Error	The time is configured for the new controller	No	Automatically when finish time configuration
E81	RTF warning	Misc. Error	Communication error between MCU and unit clock	No	Automatically when the communication recovers
E82	Probe configuration error alarm	Misc. Error	The same probes are configured	No	Automatically when the probes are configured correctly
E83	Digital inputs configuration error alarm	Misc. Error	The same digital inputs are configured	The related functions will be disabled	Automatically when the digital inputs are configured correctly
E84	Compressor configuration error alarm	Misc. Error	Digital compressor and solenoid valve configuration does not match	The compressor will not work	Manually power off and power on after the compressor configuration is right
E85	Injection probe configuration error alarm	Misc. Error	EXV and injection configuration do not match	EXV will not work	Automatically when injection probe is configured correctly
L86	EEPROM R/W error lock	Misc. Error	write/read error into EEPROM	The compressor will tripped and the unit will be locked	Hold "start" button for 5s or manual power off and on, alarm will disappear when the communication between MCU and EEPROM is success.

Alarm code	Description	Alarm type	Possible reason	Action	Reset
F01	AC input over current	Alarm	<ol style="list-style-type: none"> 1. Compressor running out of envelope 2. Input voltage out of range 3. Driver issue 	The compressor will be tripped	Automatically after timer delay
F02	DC bus over voltage	Alarm	<ol style="list-style-type: none"> 1. Input voltage higher than maximum 2. Compressor running out of envelope 	The compressor will be tripped	Automatically when DC bus voltage is smaller than settings & timer delay
F03	DC bus under voltage	Alarm	<ol style="list-style-type: none"> 1. Input voltage lower than minimum 2. Compressor running out of envelope 	The compressor will be tripped	Automatically when DC bus voltage is higher than settings & timer delay
F05	Inverter over temperature	Alarm	<ol style="list-style-type: none"> 1. Driver heatsink cooling is not good 2. Compressor running out of envelope 3. Driver issue 	The compressor will be tripped	Automatically when power module temperature low & timer delay
F06	PFC IGBT over temperature	Alarm	<ol style="list-style-type: none"> 1. Driver heatsink cooling is not good 2. Compressor running out of envelope 3. Driver issue 	The compressor will be tripped	Automatically when PFC IGBT temperature low & timer delay
F07	Lost rotor	Alarm	<ol style="list-style-type: none"> 1. Poor connection between driver and compressor motor 2. Compressor motor issue 	The compressor will be tripped	Automatically after timer delay
F10	Inverter output current imbalance	Alarm	<ol style="list-style-type: none"> 1. Poor connection between driver and compressor motor 2. Compressor motor issue 	The compressor will be tripped	Automatically after timer delay
F12	Micro electronic fault or drive EEPROM fault	Alarm	<ol style="list-style-type: none"> 1. Driver issue 	The compressor will be tripped	Automatically after timer delay & without fault
F13	Motor over speed	Alarm	<ol style="list-style-type: none"> 1. Driver issues 	The compressor will be tripped	Automatically after timer delay
F15	Compressor model configure error	Alarm	<ol style="list-style-type: none"> 1. Wrong configuration between compressor and driver 	The compressor will be tripped	Automatically after timer delay & with right configuration
F16	HP sensor type configure error	Alarm	<ol style="list-style-type: none"> 1. Wrong configuration between high pressure sensor and driver 	The compressor will be tripped	Automatically after timer delay & with right configuration
F18	Torque limit timeout	Alarm	<ol style="list-style-type: none"> 1. Compressor running out of envelope 2. Compressor issue 	The compressor will be tripped	Automatically after timer delay
F19	Inverter temperature fold back timeout	Alarm	<ol style="list-style-type: none"> 1. Driver heatsink cooling is not good 2. Compressor running out of envelope 3. Driver issue 	The compressor will be tripped	Automatically after timer delay
F20	Input current fold back timeout	Alarm	<ol style="list-style-type: none"> 1. Input voltage low 2. Compressor running out of envelope 3. Driver issue 	The compressor will be tripped	Automatically after timer delay

Alarm code	Description	Alarm type	Possible reason	Action	Reset
F21	Fold back warning	Warning	<ol style="list-style-type: none"> 1. Compressor running out of envelope 2. Driver heatsink cooling is not good 	No	Manually power-off and power-on
F24	Inverter temperature high	Alarm	<ol style="list-style-type: none"> 1. Driver heatsink cooling is not good 2. Compressor running out of envelope 3. Driver issue 	The compressor will be tripped	Automatically after timer delay & power module temperature low
F25	PFC temperature high	Alarm	<ol style="list-style-type: none"> 1. Driver heatsink cooling is not good 2. Compressor running out of envelope 3. Driver issue 	The compressor will be tripped	Automatically after timer delay & PFC-IGBT low
F26	DSP to PFC communication lost	Alarm	<ol style="list-style-type: none"> 1. Driver issue 	The compressor will be tripped	Automatically after timer delay & communication recover
F27	Com MCU to DSP communication lost	Alarm	<ol style="list-style-type: none"> 1. Driver issue 	The compressor will be tripped	Automatically after timer delay & without fault
F32	Inverter temperature low or sensor open fault	Alarm	<ol style="list-style-type: none"> 1. Poor connection between temperature sensor and driver 2. Driver issue 	The compressor will be tripped	Automatically after timer delay & without fault
F40	Modbus communication lost in driver	Alarm	<ol style="list-style-type: none"> 1. Driver communication part issues 2. Communication cable poor connection 3. Controller communication part issues 	The compressor will be tripped	Automatically when communication recover & timer delay
F41	Compressor phase over current (intermediate)	Alarm	<ol style="list-style-type: none"> 1. Compressor running out of envelope 2. Driver issues 3. Compressor motor issues 4. Wrong compressor model setting in controller 	The compressor will be tripped	Automatically after timer delay

Wiring diagrams

ZXV/ZXLV Condensing Unit Wiring Diagram 冷凝机组线路图

4XD/4XK-380V, 50/60Hz, 3Ph



NOTES 注:

- Dashed line " --- " is wired by installer. 虚线部分 " --- "由用户连接.
- Earth "E" wirings is not shown in harnesses for clarity. 为了使图面清晰, 部分接线在图中以文字说明表示, 图中 "E" 表示接地.

注意:机组必须接地!

ATTENTION: Unit Must Be Grounded!

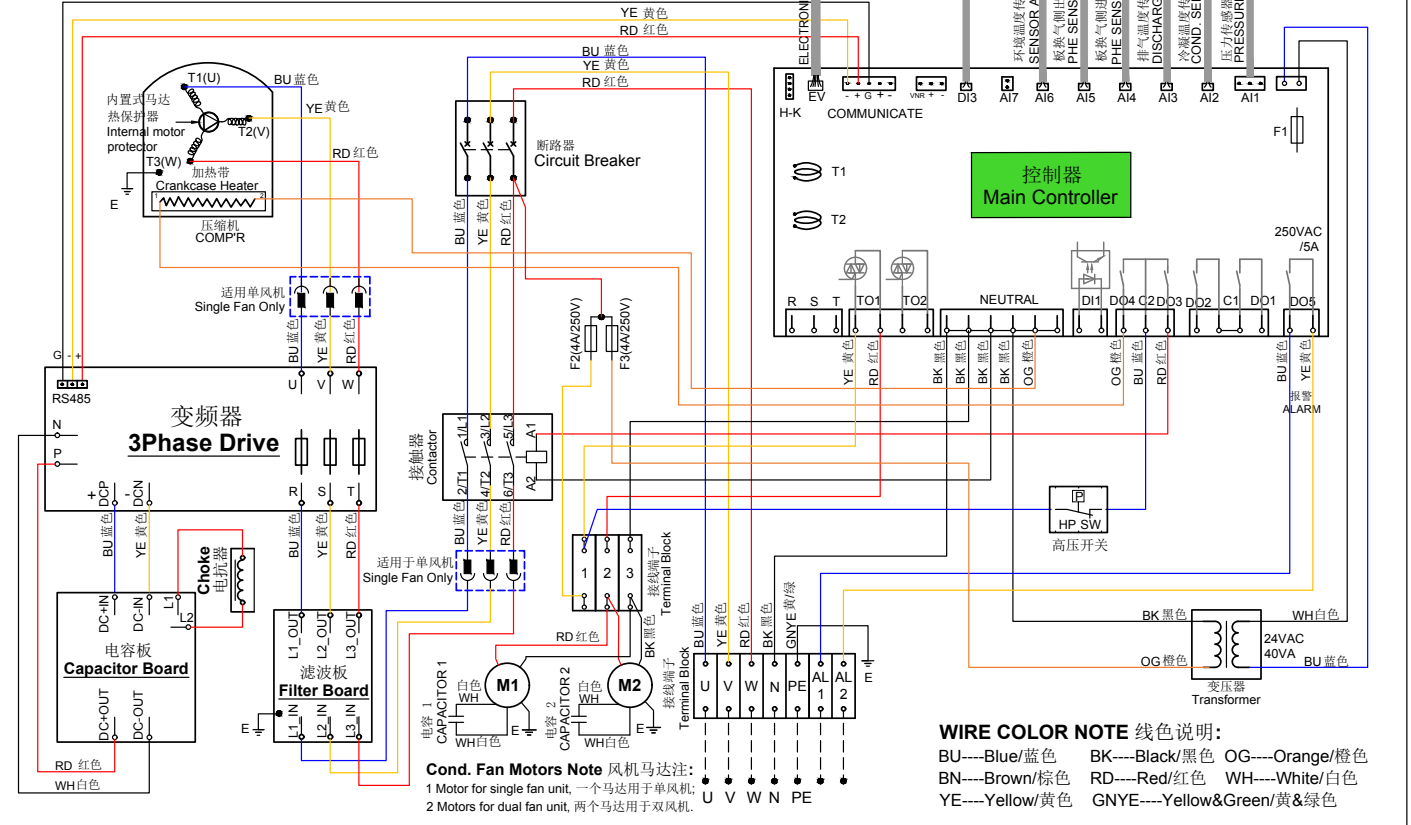

Temperature sensor resistance

Temperature (°C)	-30	-10	25	60	80	100	120
Discharge temperature Sensor resistance	1522k	457k	86k	21k	11k	5.8k	3.4k
Condensing, PHE, ambient temperature sensor resistance	111k	67.7k	42.5k	27.3k	17.9k	10k	5.82k

General information

Technical data are correct at the time of printing. Updates may occur, and should you need confirmation of a specific value, please contact Emerson clearly stating the information required.

Emerson cannot be held responsible for errors in capacities, dimensions, etc., stated herein. Products, specifications and data in this literature are subject to change without notice.

The information given herein is based on data and tests which Emerson believes to be reliable and which are in accordance with today's technical knowledge. It is intended for use by persons having the appropriate technical knowledge and skill, at their own discretion and risk. Our products are designed and adapted for fixed locations. For mobile applications, failures may occur.

The suitability for this has to be assured from the plant manufacturer, which may include making appropriate tests.

Note:

The components listed in this catalogue are not released for use with caustic, poisonous or flammable substances. Emerson cannot be held responsible for any damage caused by using these substances.

About Emerson

Emerson (NYSE: EMR), headquartered in St. Louis, Missouri (USA), is a global technology and engineering company providing innovative solutions for customers in industrial, commercial, and residential markets. Our Emerson Automation Solutions business helps process, hybrid, and discrete manufacturers maximize production, protect personnel and the environment while optimizing their energy and operating costs. Our Emerson Commercial and Residential Solutions business helps ensure human comfort and health, protect food quality and safety, advance energy efficiency, and create sustainable infrastructure. For more information visit [Emerson.com](https://www.emerson.com).

Contact lists

Asia Pacific Headquarters

Suite 2503-10A, 25/F, Exchange Tower,
33 Wang Chiu Road, Kowloon Bay,
Kowloon, Hong Kong
Tel: (852) 2866 3108
Fax: (852) 2520 6227

Australia

356 Chisholm Road
Auburn NSW 2144, Australia
Tel: (612) 9795 2800
Fax: (612) 9738 1699

China - Beijing

Room 1203-1205,
North Wing Junefield Plaza Central Tower,
No. 10 Xuan Wu Men Wai Street,
XiCheng District, Beijing, PRC
Tel: (8610) 5095 2188

China - Guangzhou

Guangzhou Office
Unit 2202B, 22/F, Leatop Plaza,
32 Zhujiang East Road, Tianhe Dist.,
Guangzhou 510623, PRC
Tel: (8620) 8595 5188

China - Shanghai

Shanghai Sales Office
7/F, Emerson Building, 1582 Gumei
Rd, Shanghai, PRC
Tel: (8621) 3338 7333

India - Mumbai

601-602, 6/F Delphi B-Wing,
Central Avenue,
Hiranandani Business Park,
Powai, Mumbai 400076, India
Tel: (9122) 6786 0793
Fax: (9122) 6662 050

India - Pune

Plot No. 23, Rajiv Gandhi Infotech Park,
Phase - II, Hinjewadi,
Pune 411 057, Maharashtra, India
Tel: (9120) 4200 2000
Fax: (9120) 4200 2099

Indonesia

14th floor, NorthTower,
Sampoerna Strategic Square
Jl. Jend. Sudirman Kav. 45-46, 12930,
Jakarta Indonesia
Tel : (6221) 2509 1400, (6221) 5793 1000
Fax : (6221) 5793 0883

Japan

No. 3-9-5 Shin-Yokohama,
Shin-yokohama Tosho Building,
Kohoku-ku, Yokohama,
222-0033 Japan
Tel: (8145) 475 6371
Fax: (8145) 475 3565

Malaysia

No. 1, Block A
Jalan SS13/5 Subang Jaya
Selangor 47500, Malaysia
Tel: (603) 5624 2888

Middle East & Africa

PO Box 26382
Jebel Ali Free Zone - South
Dubai, UAE
Tel: (9714) 811 8100
Fax: (9714) 886 5465

Philippines

10/F SM Cyber West Avenue,
EDSA cor. West Avenue,
Barangay Bungad, Diliman,
Quezon City 1105, Philippines
Tel: (632) 689 7200 ext. 4395

Saudi Arabia

PO Box 34332
3620 Building 7874, Unit 1,
67th street 2nd Industrial City
Dammam, Saudi Arabia
Toll Free: 800 844 3426
Tel: (966) 3814 7560
Fax: (966) 3814 7570

South Korea

14/F, NIA Building,
Cheonggyecheon-ro,
Jung-gu 04520, Seoul Korea
Tel: (822) 3483 1500
Fax: (822) 592 7883

Taiwan

3/F, No. 122 Lane 235,
Pao Chiau Rd., XinDianv Dist.,
New Taipei City 23145, Taiwan (R.O.C.)
Tel: (8862) 8912 1360
Fax: (8862) 8912 1890

Thailand

34/F, Interlink Tower,
1558/133, Bangna Trad,
Bangkok 10260, Thailand
Tel: (662) 716 4700
Fax: (662) 751 4241

United Arab Emirates

PO Box 26382
Jebel Ali Free Zone
Dubai, UAE
Toll Free: 800 441 3428
Tel: (971) 4811 8100
Fax: (971) 4886 5465

Vietnam

9.04/F, Block A2, Viettel Tower
285 Cach Mang Thang Tam, District 1
Ho Chi Minh City, Vietnam
Tel: (84) 28 6290 8243



Scan to visit:



Emerson Asia

Emerson.com

Asia 01 00 Issued 09/2022 Emerson is a trademark of Emerson Electric Co. or one of its affiliated companies.
©2022 Emerson Electric Co. All rights reserved.



@EmersonComResAP

EMERSON. CONSIDER IT SOLVED.™