

Variable Speed Compressors & Drive Solutions



COPELAND™



EMERSON™

Superior energy efficiency, control and reliability

To help our customers adapt to the variable speed market trend, Emerson has developed integrated solutions for 4-25 HP variable speed compressors and drives. This line of solutions is equipped with innovative technologies to support the new era of energy efficient systems. Copeland vapor injection technology ensures system reliability even in ultra-low temperature environments. Emerson EVD series drives are specially designed with permanent magnet motors and are perfectly matched with each compressor. Emerson is your one-stop-shop for solutions to meet the industry's demands.



Value for customer from Emerson solutions

- One-stop shop convenience
- Market-leading system performance
- Helps customers respond quickly to changing market trends
- Provides customers with full technical support

Compressor range

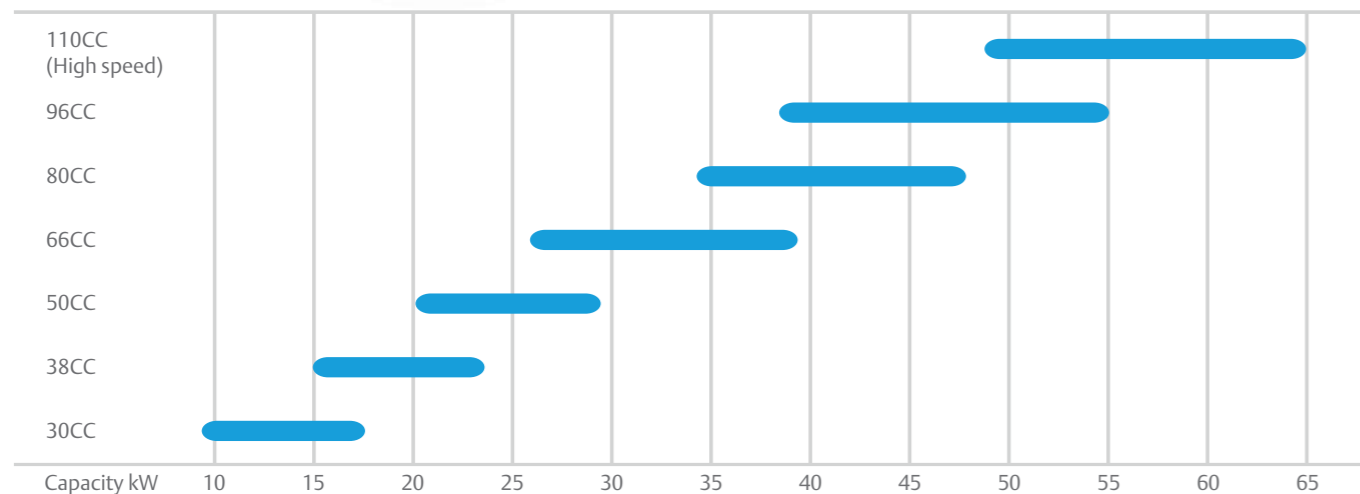

Compressor model	ZPV/ZPW030DE	ZPV/ZPW038DE	ZPV/ZPW050DE
Displacement (cc/rev)	30	38	49
Speed range (rpm)	900~7200	900~7200	1200~7200
Rated capacity (kW) @ 75 Hz	12.2	16.1	20.5
Input power (kW) @ 75 Hz	3.80	4.88	6.3
COP with drive	3.21	3.33	3.25
Noise (dBA) @ARI 75 Hz	74	74	74
Oil charge (L)	1.18	1.18	1.18
Net weight (kg)	17.8	19.8	23.5
Lubricating oil	POE	POE	POE
Single/Tandem	Single	Single	Single
Refrigerant	R410A	R410A	R410A
Drive Input current (A)	35 (Single-phase) 20 (Three-phase)	35 (Single-phase) 20 (Three-phase)	20 (Three-phase)
Drive Output current (A)	25 (Single-phase) 20 (Three-phase)	25 (Single-phase) 20 (Three-phase)	20 (Three-phase)
Drive model (Single-phase, 200V-240V, 50 Hz/60 Hz)	EVD2080B-C1-113 (Drive board) 143-0030-00 (Filter board) 037-0063-00 (Choke)	EVD2080B-C1-113 (Drive board) 143-0030-00 (Filter board) 037-0063-00 (Choke)	
Drive model (Three-phase, 380V-400V, 50 Hz/60 Hz)	EVD1080B-D1-113 (Drive board) 143-0065-00 (Filter board) 143-0066-00 (Capacitor board) 037-0068-00 (Choke)	EVD1080B-D1-113 (Drive board) 143-0065-00 (Filter board) 143-0066-00 (Capacitor board) 037-0068-00 (Choke)	EVD1110B-D1-113 (Drive board) 143-0065-00 (Filter board) 143-0066-00 (Capacitor board) 037-0068-00 (Choke)

Note:
 • ZPV = Non-EVI model
 • ZPW = EVI model
 • R32 under development

Compressor model	ZPV066	ZPV080/ZPW080	ZPV096	ZPV** (25HP)
Displacement (cc/rev)	66	80	96	100+
Speed range (rpm)	1000~7200	1200~7200	1200~7200	1800~8400
Rated capacity (kW) @ 75 Hz	28.8	38	43	68Kw @ 105Hz (EVI ON)
Input power (kW) @ 75 Hz	8.72	11.5	13	22.3
COP with drive	3.3	3.3	3.3	3.2
Noise (dBA) @ARI 75 Hz	77	80	80	90
Oil charge (L)	2.51	2.51	2.51	2.51
Net weight (kg)	40	42	44.7	Under development
Lubricating oil	POE	POE	POE	POE
Single/Tandem	Tandem	Tandem	Tandem	Tandem
Refrigerant	R410A	R410A	R410A	R410A
Drive Input current (A)	27	27	38	Under development
Drive Output current (A)	27	27	38	Under development
Drive model (Three-phase, 380V-400V, 50 Hz/60 Hz)	EVD1150B-D1-111 (Drive board) 143-0032-00 (Filter board) 143-0058-00 (Capacitor board) 037-0064-00 (Choke)	EVD1150B-D1-111 (Drive board) 143-0032-00 (Filter board) 143-0058-00 (Capacitor board) 037-0064-00 (Choke)	EVD1180B-D1-111 (Drive board) 143-0032-00 (Filter board) 143-0058-00 (Capacitor board) 037-0064-00 (Choke)	Under development

Conditions: ET =7.2°C, CT=54.4°C, SC=8.3K, SH=11.1K, Ambient temperature= 35°C

Durable, comfortable and reliable

Emerson Copeland Scroll™ variable speed compressors are revolutionizing home cooling and heating systems through Enhanced Vapor Injection (EVI) technology. Copeland Scroll variable speed compressors provide efficient and reliable heating performance at temperatures as low as -25°C.

The drive and compressor were specially developed by the Emerson Suzhou R&D Center for the Asian market and optimized according to IPLV/APF standards. The Enhanced Vapor Injection (EVI) technology significantly improves heating capacity at low ambient temperatures. The optimized design of the compressor, with the world's top energy efficiency ratio and lower noise performance, allows you to significantly reduce your electricity costs while enjoying indoor comfort throughout the year.

Enhanced vapor injection (EVI) technical features:

- Patented vapor injection design
- When the EVI circuit gas enters the compressor, it is injected into the scroll set through a specially designed channel. The gas is injected is compressed and discharged together and directed into the suction port entering the refrigeration cycle.
- EVI technology increases heating capacity while decreasing the discharge temperature.
- Capability for replacing auxiliary electric heating.

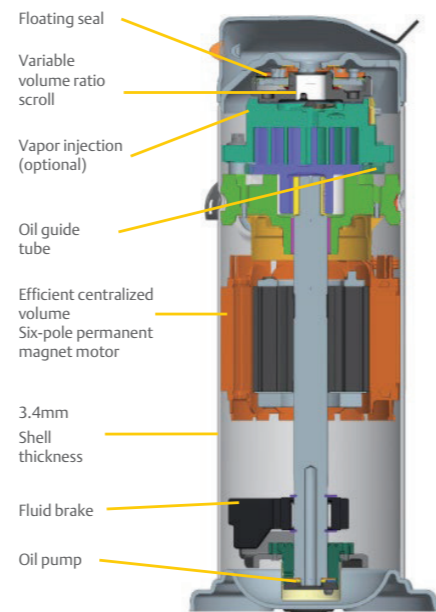

Copeland Scroll variable speed advantages:

- Excellent performance and low noise operation
- Outstanding reliability
- Efficient Emerson permanent magnet motor for efficient energy savings
- Suzhou R&D Center develops systems tailored for the Asia Pacific market
- Widely used in applications like variable speed VRF, cabinet air conditioner, floor heating etc.
- 900-7200 rpm wide operating envelope for flexible system design
- Variable volume ratio (VVR) significantly improves energy efficiency at low scroll speeds



Innovation Product Award
China Refrigeration 2014

Operating envelope

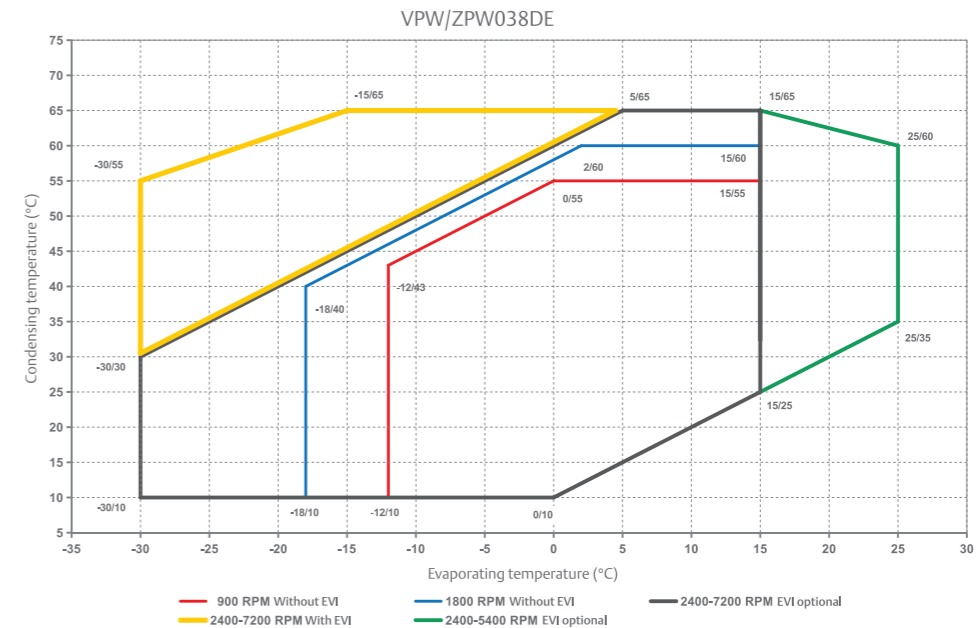

EVI technology significantly improves the operating range of compressors at low temperatures

Nomenclature (53Fr Variable speed compressor)

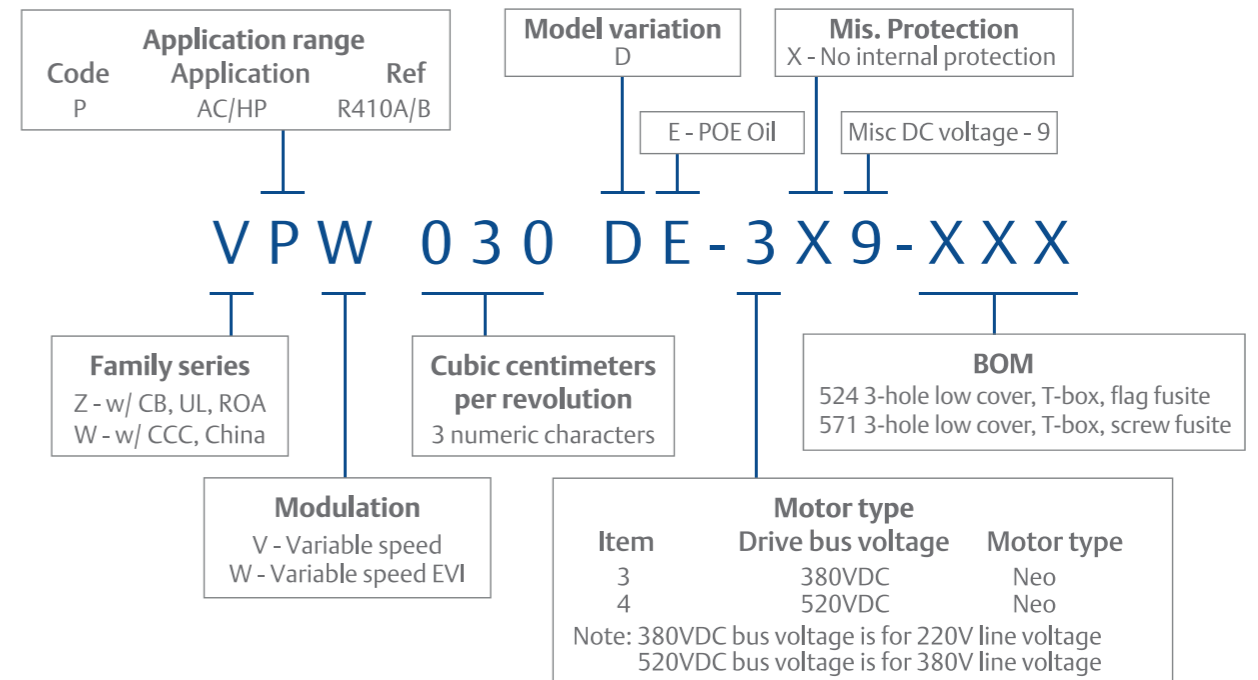

Maximizing the performance of commercial air conditioning systems

Proven Copeland Scroll™ platform-enhanced and optimized for variable speed

- Optimized scroll elements for variable speed performance
- Low oil circulation compressor plus scroll oil injection for low speed performance
- BPM motor technology for highest efficiency
- Sound reduction technology for reversible chiller transition and defrost

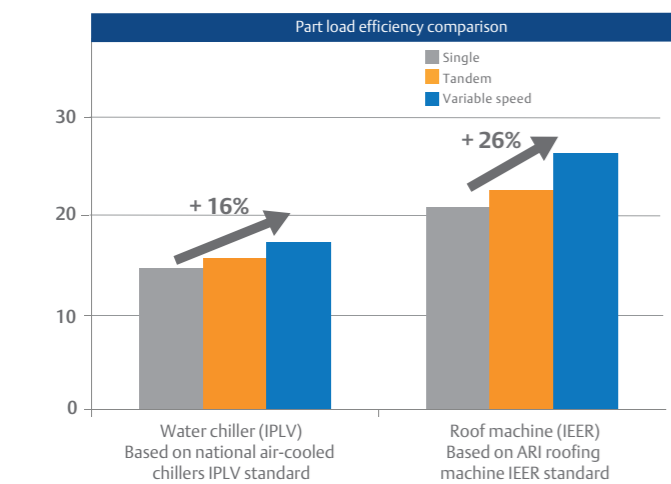
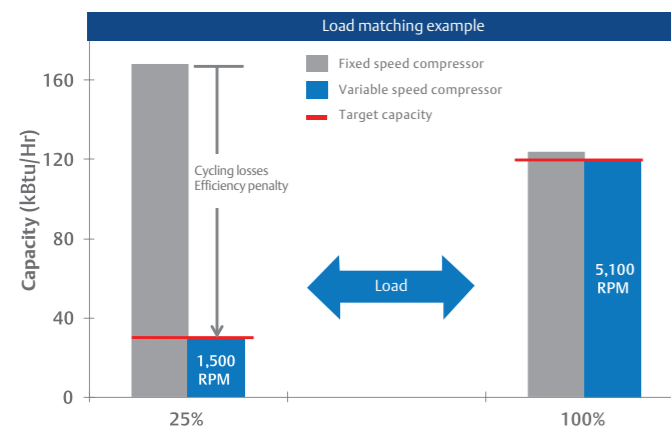

The unparalleled energy efficiency of the Copeland Scroll inverter compressor maximizes system efficiency



Breakthrough energy efficiency

Emerson's Copeland Scroll variable speed compressors are designed to deliver maximum cooling and heating efficiency when you need it the most. Whether designing for a roof-top unit in Australia or the United States or an air-cooled chiller in Europe or Asia, our latest variable speed compressor technology allows system manufacturers and building owners to achieve superior performance, including:

- Expansive 1,000-7,200 RPM speed range for enhanced light load efficiency and dehumidification.
- Highest part load efficiency in its class enabling significant energy savings and standards compliance
- Capability to 'tandemize' for maximum flexibility in system design
- Both compressor and drive are prequalified for reduced design time, cost and speed to market.

Operating envelope

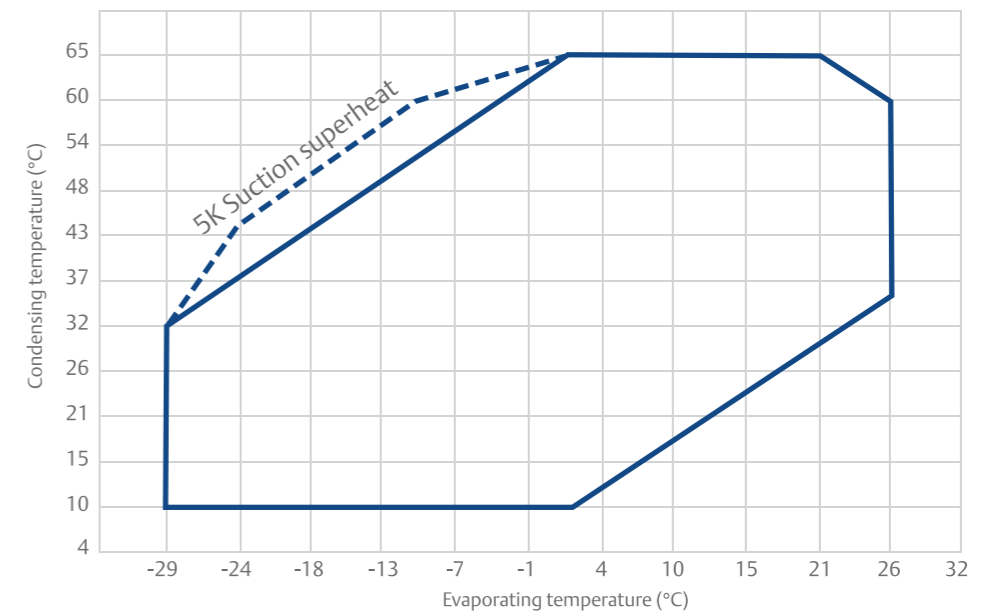

Based on: 11.1K SH, 8.3K SC, 35.0 C Ambient (Solid line boundaries)
Refer to application engineering bulletin for details on the speed range throughout the operating envelope.

Variable speed compressor nomenclature

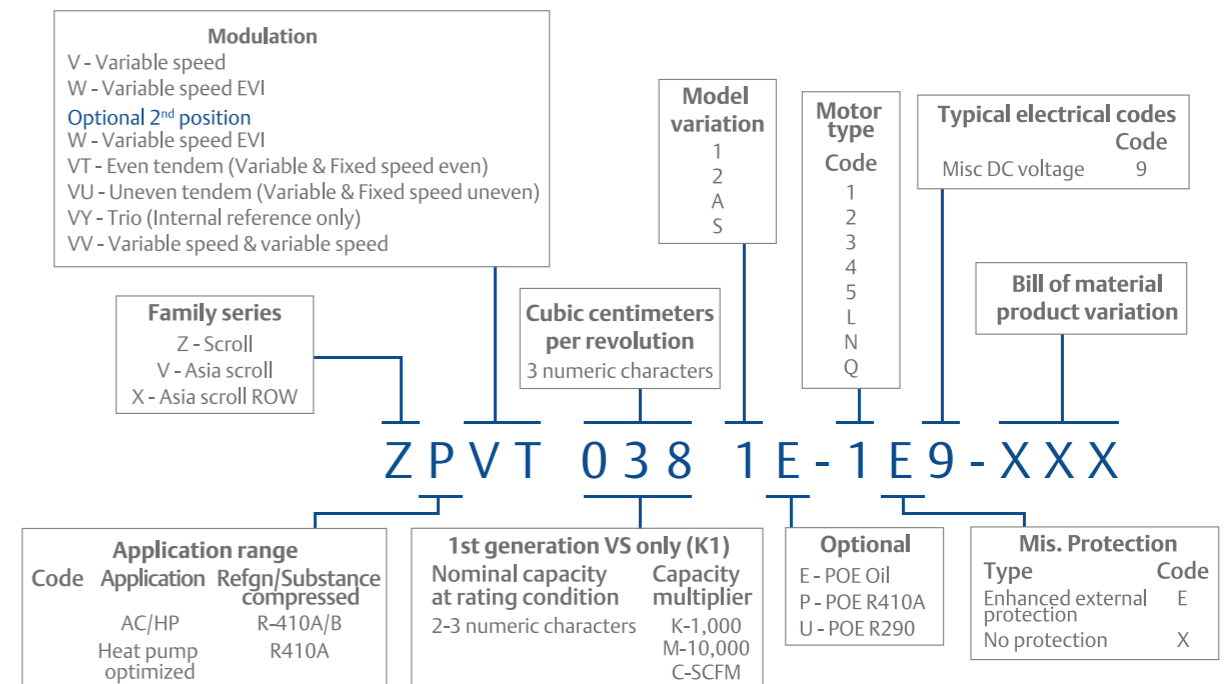

The latest in technology and value

Variable speed drives features and benefits:

- Fully optimized drive and motor design
- Improved reliability through protection and control features
- Reduced system design time and effort
- Communication set up Baud rate 2400

- Full compressor compatibility, plug and play capability

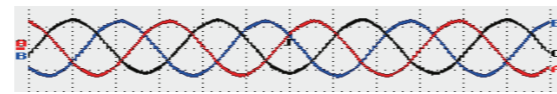

Current specification

Drive model	Input voltage	Maximum input current	Maximum output current
EVD1180B-D1-111	3PH, 340V~440V, 50 Hz/60 Hz	38A	38A
EVD1150B-D1-111	3PH, 340V~440V, 50 Hz/60 Hz	27A	27A
EVD1110B-D1-113	3PH, 340V~440V, 50 Hz/60 Hz	21A	21A
EVD1080B-D1-113	3PH, 340V~440V, 50 Hz/60 Hz	17A	17A
EVD2080B-C1-113	1PH, 160V~265V, 50 Hz/60 Hz	35A	25A

Drive components

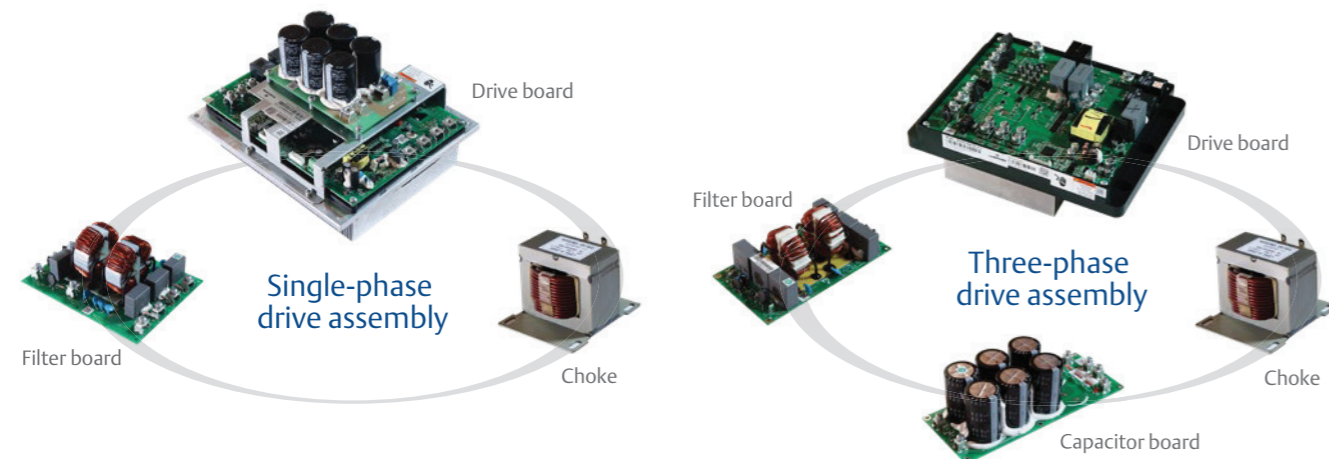

Variable speed drive nomenclature

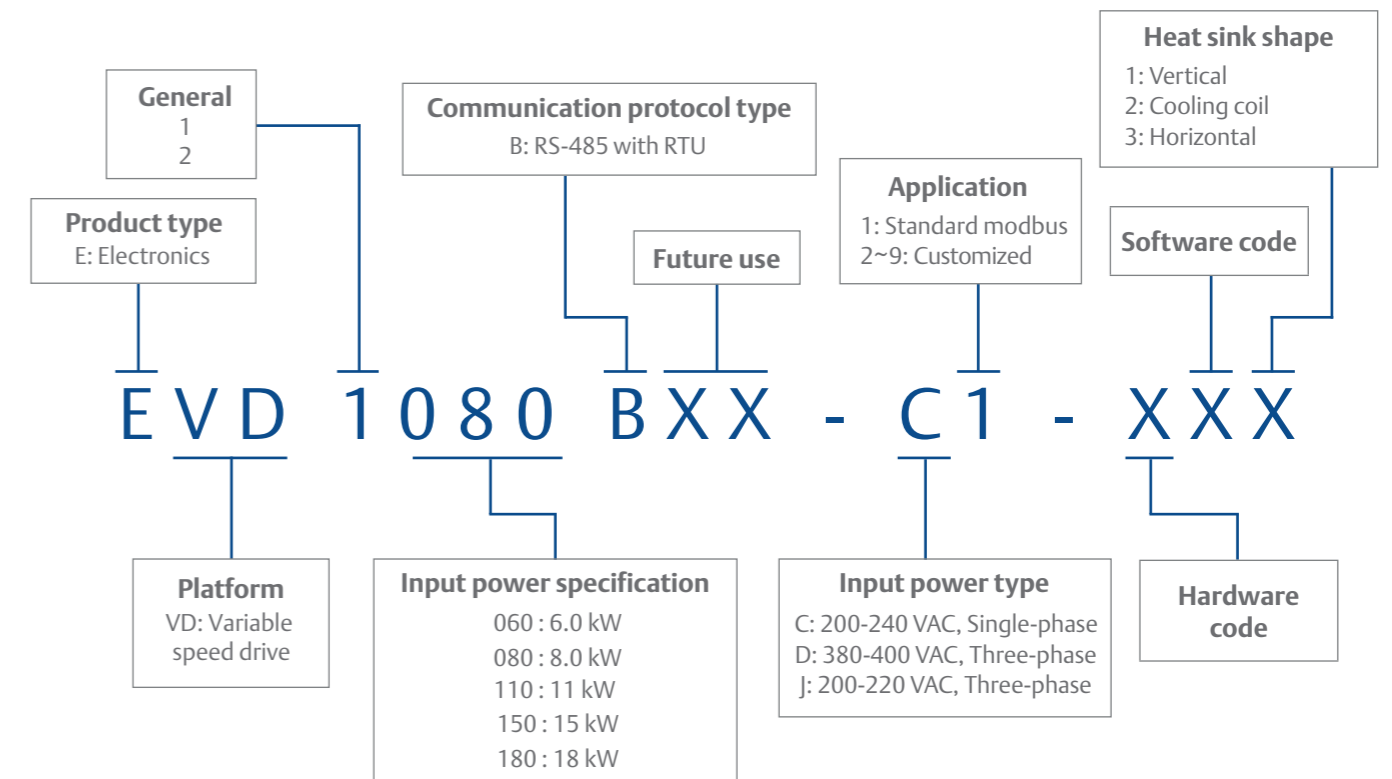

Emerson drive advantage

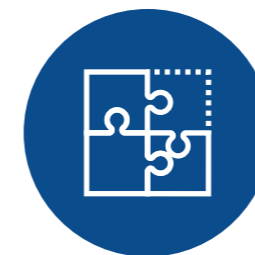

Full compatibility with Emerson variable speed compressors



Trusted reliability

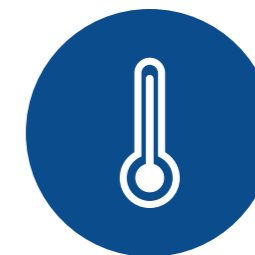

Excellent drive board heat resistance



Specially designed EMC

Contact lists

Asia Pacific Headquarters

Suite No. 2503-10A, 25/F,
Exchange Tower, 33 Wang Chiu Road,
Kowloon Bay, Kowloon, Hong Kong
Tel: (852) 2866 3108
Fax: (852) 2520 6227

Australia

356 Chisholm Road
Auburn NSW 2144, Australia
Tel: (612) 9795 2800
Fax: (612) 9738 1699

China - Beijing

Room 1203-1205,
North Wing Junefield Plaza Central Tower,
No. 10 Xuan Wu Men Wai Street,
XiCheng District, Beijing, PRC
Tel: (8610) 5095 2188

China - Guangzhou

Guangzhou Office
Unit 2202B, 22/F, Leatop Plaza,
32 Zhujiang East Road, Tianhe Dist.,
Guangzhou 510623, PRC
Tel: (8620) 8595 5188

China - Shanghai

Shanghai Sales Office
7F, Emerson Building, 1582 Gumei
Rd, Shanghai, PRC
Tel: (8621) 3338 7333

India - Mumbai

Delphi B-Wing, 601-602, 6th Floor
Central Avenue,
Hiranandani Business Park,
Powai, Mumbai 400076, India
Tel: (9122) 6786 0793
Fax: (9122) 6662 0500

India - Pune

Plot No. 23, Rajiv Gandhi Infotech Park,
Phase - II, Hinjewadi,
Pune 411 057, Maharashtra, India
Tel: (9120) 4200 2000
Fax: (9120) 4200 2099

Indonesia

BSD Taman Tekno 8
Jl. Tekno Widya Blok H10 No 2 & 3
Tangerang Selatan 15314
Indonesia
Tel: (6221) 2966 6242
Fax: (6221) 2966 6245

Japan

Shin-yokohama Tosho Building
No. 3-9-5 Shin-Yokohama, Kohoku-ku
Yokohama 222-0033 Japan
Tel: (8145) 475 6371
Fax: (8145) 475 3565

Malaysia

Level M2, Blk A, Menara PKNS-PJ
Jalan Yong Shook Lin
46050 Petaling Jaya, Selangor, Malaysia
Tel: (603) 7949 9222
Fax: (603) 7949 9333

Middle East & Africa

PO Box 26382
Jebel Ali Free Zone - South
Dubai, UAE
Tel: (9714) 811 8100
Fax: (9714) 886 5465

Philippines

10/F SM Cyber West Avenue, EDSA cor.
West Avenue, Barangay Bungad,
Diliman, Quezon City 1105 Philippines
Tel: (632) 689 7200

Saudi Arabia

PO Box 34332 - 3620 Building 7874
Unit 1, 67th street 2nd Industrial City
Dammam, Saudi Arabia
Toll Free: 800 844 3426
Tel: +966 3 8147560
Fax: +966 3 8147570

South Korea

3F, The Pinnacle Gangnam
343, Hakdong-ro, Gangnam-gu,
Seoul 06060, Republic of Korea
Tel: (822) 3483 1500
Fax: (822) 592 7883

Taiwan

3F No. 122 Lane 235,
Pao Chiau Rd., XinDianv Dist.,
New Taipei City 23145, Taiwan (R.O.C.)
Tel: (8862) 8912 1360
Fax: (8862) 8912 1890

Thailand

34th Floor, Interlink Tower,
1858/133, Bangna Trad,
Bangkok 10260, Thailand
Tel: (662) 716 4700
Fax: (662) 751 4241

United Arab Emirates

Jebel Ali Free Zone
PO Box 26382
Dubai UAE
Toll Free: 800 441 3428
Tel: +971 4 811 8100
Fax: +971 4 886 5465

Vietnam

Level 6, Melinh Point Tower,
2 Ngo Due Ke,
District 1, Ho Chi Minh City
Vietnam
Tel: (84) 908 009 189

Scan to visit:



Emerson Asia

Emerson.com

Asia 01 00 Issued 8/2019 Emerson is a trademark of Emerson Electric Co. or one of its affiliated companies.
©2019 Emerson Electric Co. All rights reserved.



@EmersonComResAP

EMERSON. CONSIDER IT SOLVED.™