

# Application Guidelines

## Copeland Scroll™ Variable Speed Heat Pump Compressors for Residential Comfort

ZHW015\* & ZHW030\*



<b>About these guidelines .....</b>	<b>1</b>
<b>1 Safety instructions .....</b>	<b>1</b>
1.1 Icon explanation .....	1
1.2 Safety statements .....	1
1.3 General instructions .....	2
<b>2 Product description .....</b>	<b>3</b>
2.1 Common information about Copeland Scroll™ compressors.....	3
2.2 Variable speed advantages .....	4
2.3 Compressor and drive nomenclature.....	4
2.4 Application considerations .....	5
2.4.1 Qualified refrigerant and oil .....	5
2.4.2 Admissible pressure, temperature and relative humidity ranges .....	5
2.4.3 Application limits – Operating envelopes .....	5
2.4.4 Design features .....	8
2.4.5 Dimensions.....	9
2.4.6 Oil recovery .....	9
<b>3 Installation .....</b>	<b>10</b>
3.1 Compressor and drive handling.....	10
3.1.1 Compressor transport and storage .....	10
3.1.2 Compressor positioning and securing.....	10
3.1.3 Installation location.....	10
3.1.4 Compressor mounting parts.....	11
3.2 Compressor brazing procedure .....	11
3.3 Accumulators .....	12
3.4 Screens .....	13
3.5 Mufflers .....	13
3.6 Sound shell .....	13
3.7 Reversing valves.....	14
3.8 Sound and vibrations .....	14
<b>4 Electrical connection .....</b>	<b>16</b>
4.1 Recommendations for the drive .....	16
4.2 General recommendations.....	16
4.3 Electrical installation .....	16
4.4 Wiring diagrams .....	17
4.4.1 Motor windings .....	18
4.4.2 Protection devices .....	18
4.4.3 Crankcase heating function.....	18
4.5 Pressure safety controls .....	19
4.5.1 High-pressure protection.....	19
4.5.2 Low-pressure protection.....	19

4.6	Discharge gas temperature protection.....	19
4.7	High-potential testing .....	20
<b>5</b>	<b>Starting up &amp; operation.....</b>	<b>21</b>
5.1	Strength pressure test.....	21
5.2	Compressor tightness test .....	21
5.3	Preliminary checks – Pre-starting .....	21
5.4	Charging procedure .....	22
5.5	Run-in time.....	22
5.6	Initial start-up .....	22
5.7	Starting and stopping routine .....	22
5.8	Starting sound.....	22
5.9	Deep vacuum operation.....	23
5.10	Shell temperature.....	23
5.11	Pumpdown cycle.....	23
5.12	Minimum run time .....	23
5.13	Oil level .....	23
<b>6</b>	<b>Maintenance &amp; repair .....</b>	<b>24</b>
6.1	Exchanging the refrigerant.....	24
6.2	Replacing a compressor .....	24
6.2.1	Compressor replacement.....	24
6.2.2	Start-up of a new or replacement compressor .....	24
6.3	Lubrication and oil removal .....	25
6.4	Oil additives .....	25
6.5	Unbrazing system components .....	26
<b>7</b>	<b>Troubleshooting.....</b>	<b>27</b>
<b>8</b>	<b>Dismantling &amp; disposal.....</b>	<b>30</b>
<b>9</b>	<b>Reference list of related technical information .....</b>	<b>30</b>
	<b>DISCLAIMER .....</b>	<b>31</b>

## About these guidelines

The purpose of these guidelines is to provide guidance in the application of Copeland Scroll™ compressors and Emerson motor control drives in users' systems. They are intended to answer the questions raised while designing, assembling and operating a system with these products.

Besides the support they provide, the instructions listed herein are also critical for the proper and safe functioning of the compressors. Emerson cannot guarantee the performance and reliability of the products if they are misused in regard of these guidelines.

These application guidelines cover stationary applications only. For mobile applications, please contact the Application Engineering department at Emerson as other considerations may apply.

## 1 Safety instructions







Copeland Scroll compressors and Emerson motor control drives are manufactured according to the latest European and US safety standards. Particular emphasis has been placed on the user's safety.

These compressors and drives are intended for installation in systems in accordance with the European Machinery directive MD 2006/42/EC and Electromagnetic Compatibility directive EMC 2014/30/EU. They may be put to service only if they have been installed in these systems according to instructions and conform to the corresponding provisions of legislation. For relevant standards please refer to the Manufacturer's Declaration, available at [www.climate.emerson.com/en-gb](http://www.climate.emerson.com/en-gb).

These instructions should be retained throughout the lifetime of the compressor and the drive.

**You are strongly advised to follow these safety instructions. Failure to follow these instructions could result in serious injury.**

### 1.1 Icon explanation

 <p><b>WARNING</b> This icon indicates instructions to avoid personal injury and material damage.</p>	 <p><b>CAUTION</b> This icon indicates instructions to avoid property damage and possible personal injury.</p>
 <p><b>High voltage</b> This icon indicates operations with a danger of electric shock.</p>	 <p><b>IMPORTANT</b> This icon indicates instructions to avoid malfunction of the compressor.</p>
 <p><b>Danger of burning or frostbite</b> This icon indicates operations with a danger of burning or frostbite.</p>	<p><b>NOTE</b> This word indicates a recommendation for easier operation.</p>
 <p><b>Explosion hazard</b> This icon indicates operations with a danger of explosion.</p>	

### 1.2 Safety statements

- Refrigerant compressors must be employed only for their intended use.
- Only qualified and authorized HVAC or refrigeration personnel are permitted to install, commission and maintain this equipment.
- Electrical connections must be made by qualified electrical personnel.
- All valid standards for connecting electrical and refrigeration equipment must be observed.
- The national legislation and regulations regarding personnel protection must be observed.



**Use personal safety equipment.** Safety goggles, gloves, protective clothing, safety boots and hard hats should be worn where necessary.

## 1.3 General instructions



### WARNING

**Electrical shock hazard! Serious personal injuries and/or system breakdown!** Disconnect and lock out power before servicing. Allow drive components to electrically discharge for a minimum of two minutes before servicing. Use compressor with grounded system only. Moulded electrical plugs must be used in all applications. Refer to original equipment wiring diagrams. Electrical connections must be made by qualified electrical personnel.



### WARNING

**Pressurized system! Serious personal injuries and/or system breakdown!** The system contains refrigerant and oil under pressure. The mixture of air and oil at high temperature can lead to an explosion (Diesel effect). Avoid operating with air.

Never install a system in the field and leave it unattended when it has no charge, a holding charge, or with the service valves closed without electrically locking out the system.

Only approved refrigerants and refrigeration oils must be used.

Remove refrigerant from both high- and low-pressure sides with a suitable recovery unit before removing compressor.



### WARNING

**High shell temperature! Burning!** Do not touch the compressor until it has cooled down. Ensure that other materials in the area of the compressor do not get in touch with it. Lock and mark accessible sections.

Proceed with caution when brazing system components.



### CAUTION

**Overheating! Bearing damage!** Do not operate compressors without refrigerant charge or without being connected to the system.



### CAUTION

**Contact with POE! Material damage!** POE lubricant must be handled carefully and the proper protective equipment (gloves, eye protection, etc.) must be used at all times. POE must not come into contact with any surface or material that it might damage, including without limitation, certain polymers, eg, PVC/CPVC and polycarbonate.



### IMPORTANT

**Transit damage! Compressor malfunction!** Use original packaging. Avoid collisions and tilting.

## 2 Product description

### 2.1 Common information about Copeland Scroll™ compressors

The Scroll compressor has been under development at Emerson since 1979. It is the most efficient and durable compressor Emerson has ever developed for air conditioning, refrigeration and heating applications.

**These application guidelines deal with the second generation of variable speed Copeland Scroll compressors with vapour injection (EVI) ZHW015\* & ZHW030\*.** These compressors have a speed range of 900 to 7000 revolutions per minute, corresponding to 15 up to 117 Hz. They are intended for use in air conditioning, and in either air-source or geothermal residential heat pump applications. They feature a three-phase brushless permanent magnet (BPM) motor which is controlled by an Emerson motor control drive, referred to as the "drive" throughout these guidelines.

**NOTE: For more information on the motor control drive refer to Application Engineering bulletins AE-1405 (1 phase) or AE-1411(3 phase).**



Figure 1: 5.5 kW drive

The compressor models are listed in **Table 1**.

The ZHW compressors have been qualified for use with the Emerson motor control drive EV2, and the combination of both has been designed for maximum efficiency and reliability. The drive will power the compressor, control the compressor running speed, provide compressor and drive protection and communicate with the master controller in ModBus RTU protocol. The drive requires cooling and is typically installed in the unit near the compressor. To optimize drive efficiency and to limit the electromagnetic interferences, filter board and chokes must be connected to the single-phase and three-phase drives.

The customer may use a third-party drive. A third-party control system must include discharge temperature protection, current overload protection, and a soft start and stopping routine. Stator heat control is also recommended for optimal performance and reliability. It should also include the operating map parameters. Contact the Application Engineering department at Emerson for compressor motor specifications and speed adjustment requirements.

It is important to ensure correct wiring at both the compressor and drive connections prior to starting the compressor to avoid a mis-wire or powered reverse situation. Both situations could potentially cause compressor damage.

Scroll model	Power supply	Heating capacity kW				
		2400	3000	4500	6000	6600
ZHW015	1-Phase 208-240V, 50/60 Hz	3.35	4.29	6.69	9.04	9.94
ZHW015	3-Phase 380-480V, 50/60 Hz	3.39	4.32	6.69	9.04	9.94
ZHW030	1-Phase 208-240V, 50/60 Hz	6.77	8.52	12.84	17.13	18.87
ZHW030	3-Phase 380-480V, 50/60 Hz	6.84	8.61	12.97	17.31	19.07

Table 1: Heating capacity in kW

## Conditions:

Evaporating dew temperature .....-7°C  
 Suction gas superheat .....5K  
 Injection superheat (EVI) .....5K

Condensing dew temperature .. 50°C  
 Condenser sub-cooling ..... 5K  
 Economizer approach (EVI) ..... 5K

## 2.2 Variable speed advantages

The variable speed scroll is a key component in the variable capacity system. A variable capacity system will use less electrical energy by minimizing on-off cyclical losses, maximizing heat exchanger efficiency by operating at part load during a majority of the total operating hours, and by operating with reduced airflow rates and blower power.

The variable speed scroll and drive are suitable for a variety of "best-in-class" applications. Both may be used in other types of applications provided that the envelope and other operating restrictions are met. The primary benefit of this product is to substantially reduce electrical energy consumption and associated expenses.

Additionally, a variable speed scroll offers the capability of controlling space and domestic hot water temperature to ranges exceeding simple on-off control, improving overall comfort levels inside the building. The onboard electronics embedded in the drive greatly reduce the possibility of operation outside the designed parameters which in turn increases overall system reliability.

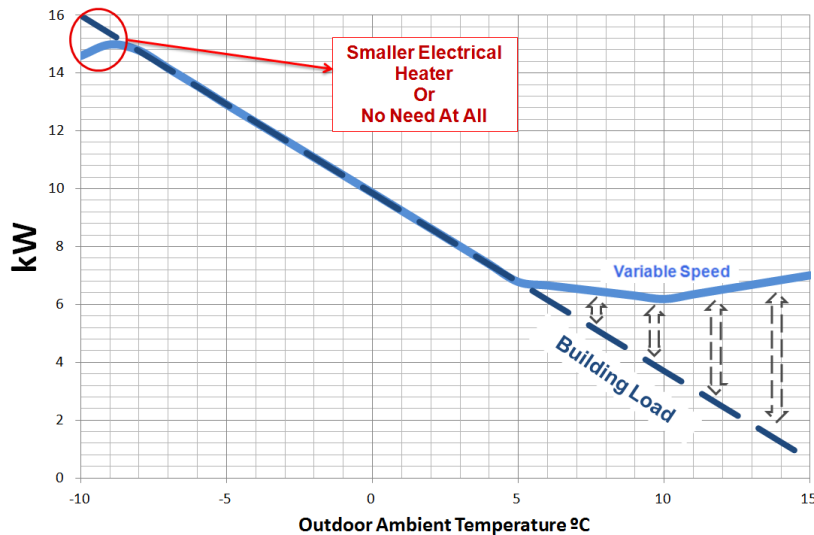

Figure 2: Variable speed solution to follow the building heat demand

## 2.3 Compressor and drive nomenclature

The compressor and drive model designation contains the following technical information:

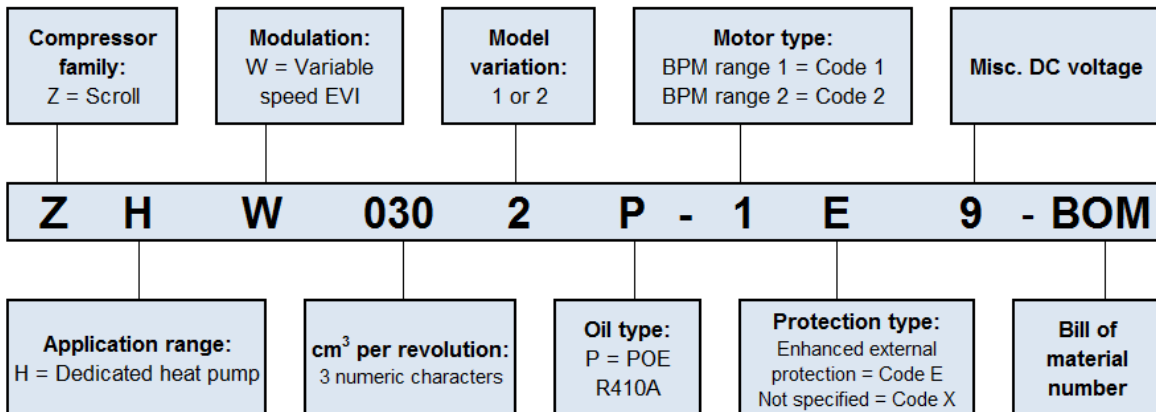

Figure 3: Compressor nomenclature

**2.4 Application considerations**

**2.4.1 Qualified refrigerant and oil**

Oil recharge values can be taken from Copeland Scroll compressors brochures or Copeland™ brand products Select software available at [www.climate.emerson.com/en-gb](http://www.climate.emerson.com/en-gb).

<b>Compressors</b>	<b>ZHW0152P &amp; ZHW0302P</b>
<b>Qualified refrigerant</b>	<b>R410A</b>
<b>Copeland brand products standard oil</b>	Emkarate RL 32 3MAF

Table 2: Qualified refrigerant and oil

**2.4.2 Admissible pressure, temperature and relative humidity ranges**

The maximum allowable pressures for which the compressors are designed (Ps) are shown in **Table 3**.

Safety is established in compliance with all the relevant standards applicable to the given product.

<b>Compressor model</b>	<b>Ps (low-pressure side)</b>	<b>Ps (high-pressure side)</b>
ZHW0152P	28 bar(g)	46 bar(g)
ZHW0302P	28 bar(g)	46 bar(g)

Table 3: Maximum allowable pressures

The Scroll compressor must comply with the ambient temperature and humidity ranges specified in **Table 4** below, both for storage and in operation.

<b>Compressor model</b>	<b>Compressor</b>		
	<b>Min / max relative humidity</b>	<b>Min / max ambient temperatures in storage or at standstill</b>	<b>Min / max ambient temperatures in operation</b>
ZHW*	30 / 95% No condensing	-40°C / 50°C	-40°C / 60°C

Table 4: Acceptable ambient temperature and humidity ranges for the compressor

**2.4.3 Application limits – Operating envelopes**



**CAUTION**

**Inadequate lubrication! Compressor breakdown!** Copeland Scroll compressors are qualified for operation inside the envelope published by Emerson. The envelope is defined according to Emerson’s testing and experience. Operating a compressor outside the envelope might lead to compressor failure which would be the heat pump manufacturer’s responsibility. The superheat at the compressor suction inlet must always be sufficient to ensure that no refrigerant droplets enter the compressor. For a typical evaporator-expansion valve configuration a minimum stable superheat of at least 5K is required. In the same way, the superheat at the compressor suction must always stay below a maximum limit specified by Emerson, depending on the model and for which the operating envelope is defined.

The ZHW operating envelopes depend on the running speed. The envelope limitations are mainly related to lubrication and power limitation.

The lower right boundary of the operating envelope is the minimum compression ratio required to keep the scrolls loaded. Operation below this boundary could result in the compressor intermittently loading and unloading and noisy operation.

The upper left boundary of the envelope represents the maximum compression ratio. If the operating condition approaches this boundary the compressor discharge temperature will begin to approach the maximum scroll temperature allowed by the discharge line thermistor. The thermistor must signal the drive or system unit controller to shut down if the discharge line temperature exceeds the specified temperature on the operating envelope.



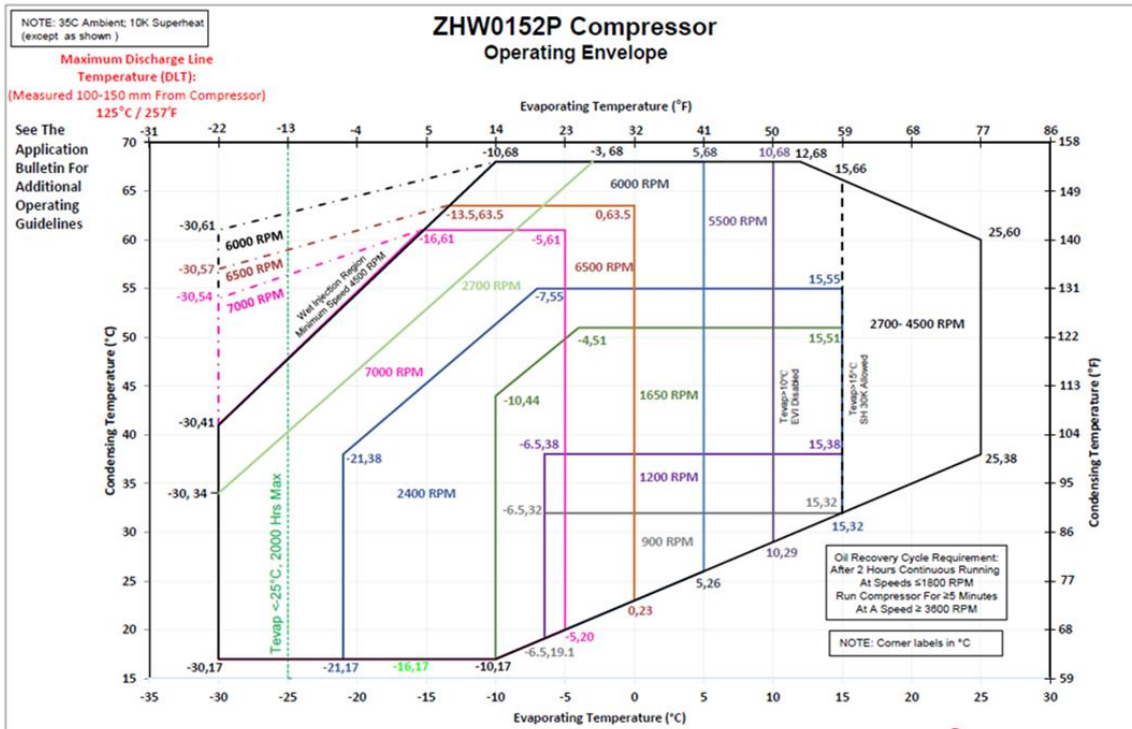

Figure 4: R410A application envelope for the ZHW0152P running with 10K suction superheat

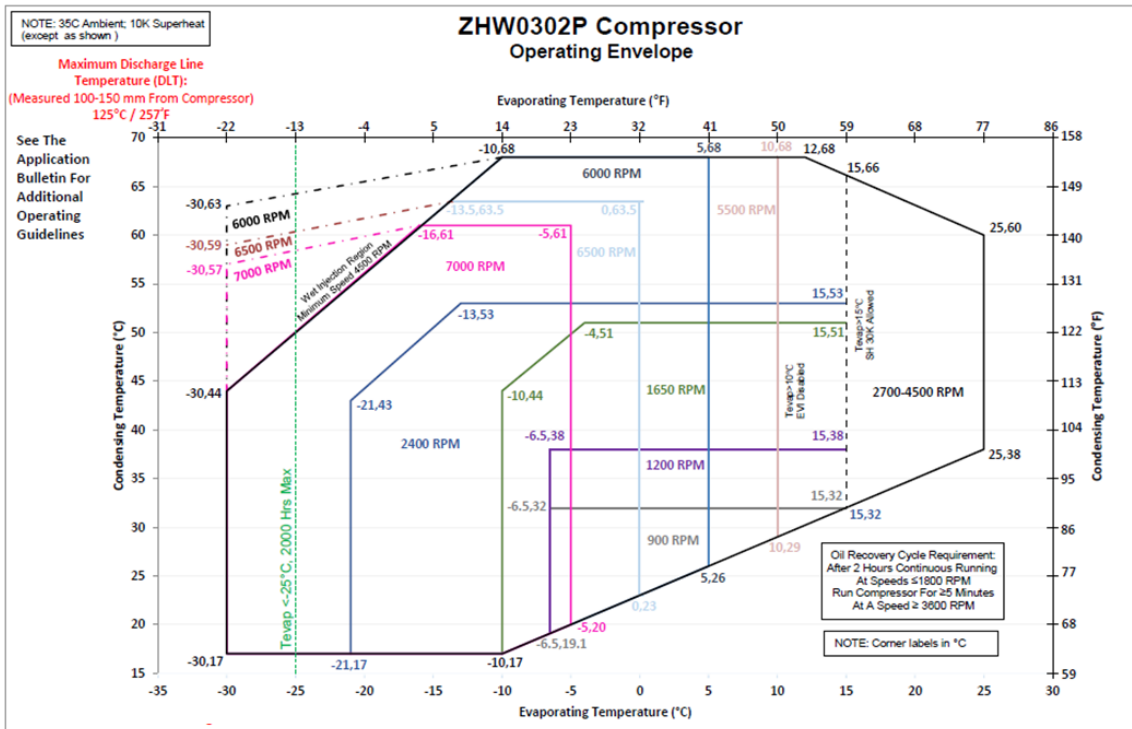

Figure 5: R410A application envelope for the ZHW0302P running with 10K suction superheat

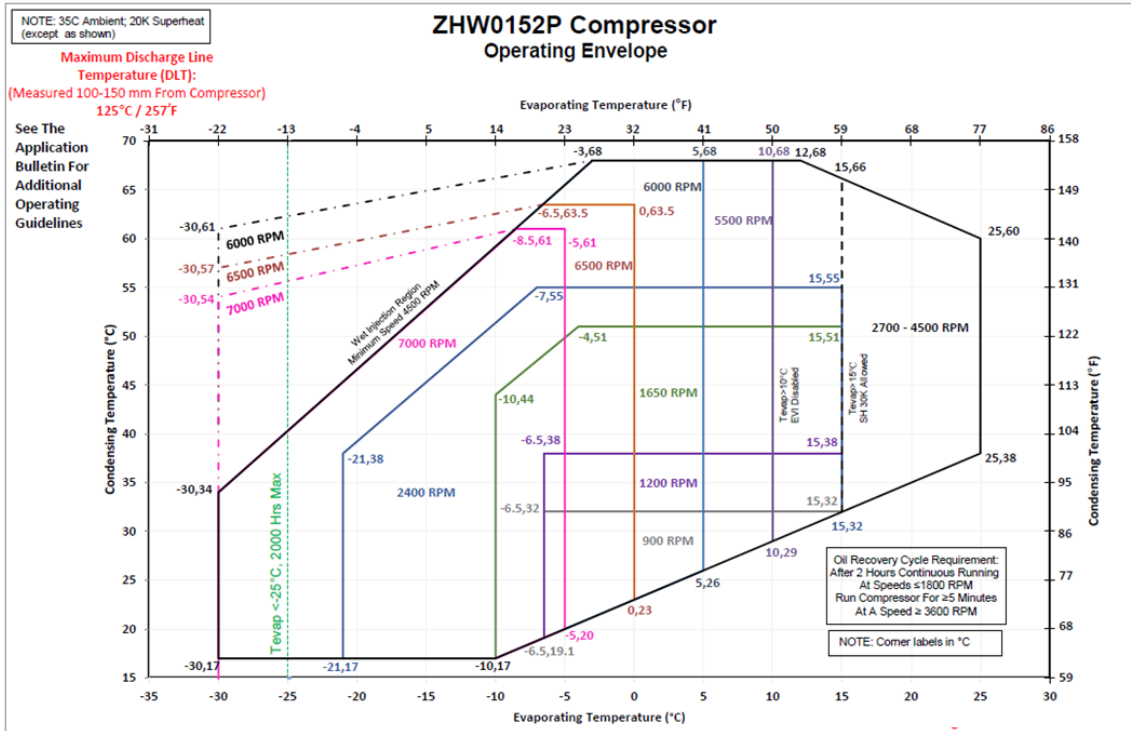

Figure 6: R410A application envelope for the ZHW0152P running with 20K suction superheat

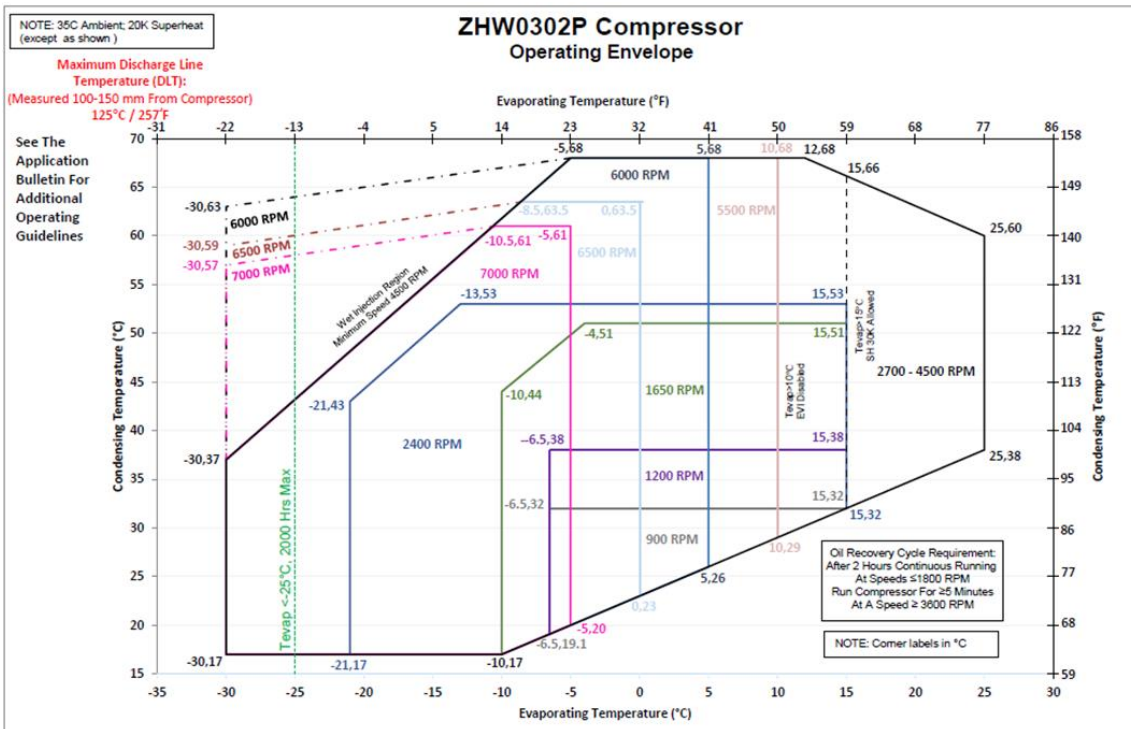

Figure 7: R410A application envelope for the ZHW0302P running with 20K suction superheat

Please note some comments about the envelope:

- The use of 900 rpm for low condensing temperatures is possible as shown in the envelope.
- When the compressor is operated for more than 120 minutes with a speed below 1800 rpm it has to run for at least 5 minutes with a speed of 3600 rpm to make sure that there is enough oil circulation inside the compressor.
- Additionally, an oil return test for the system must be performed. If required, the system design should be improved.
- The system should be able to bring the compressor at the start as fast as possible to a point inside the envelope and keep the compressor running there. Running outside the envelope is not allowed. Emerson's recommendation is to start with a speed of 3000 rpm.
- Running/oscillating the compressor in and out of the envelope borders is not allowed and should be avoided.
- Running the compressor below the envelope at low condensing temperatures is possible for no longer than 30 minutes but users must be aware that unloading noise from the compressor can occur. In this area the speed limits according to the evaporating temperatures in the envelope should be respected.
- The minimum speed at the current condition should be linear interpolated between the lines, eg, when you go above the line with the minimum speed of 900 rpm you should start interpolating the minimum speed linear from 900 rpm to 1200 rpm before crossing the next speed limit line.
- When you want to run inside the wet-injection area you should reach the minimum speed (4500 rpm) before entering this area.
- When you want to run inside the area with a high evaporating temperature ( $> 15^{\circ}\text{C}$ ) you should reach the minimum speed (2700 rpm) before entering this area.
- Close EVI when the evaporating temperature is higher than  $+10^{\circ}\text{C}$ .
- Users should adequately take care of controlling the envelope.

Before first start, each drive has to be set with the compressor model. This provides a speed-dependent maximum torque protection related to the compressor model. The maximum torque requirement will follow, with some margin, the maximum condensing temperature line for each speed. If the torque exceeds the maximum torque allowed for a specific speed, the drive will reduce the speed of the compressor in an attempt to keep the operating condition within the operating envelope. If reducing the speed of the compressor does not bring the condensing temperature back down within the envelope, the drive will go to the next level of protection and shut down the compressor.

This drive feature aims to protect the drive and the compressor. It cannot be used in the system as an operating envelope limitation.

For air-to-water heat pump applications, a supplementary envelope extension for high temperature water production can be used in case of low outdoor temperature. This can be achieved on ZHW models by the use of wet vapour injection. For further information about wet vapour injection, contact the Application Engineering department at Emerson.

The operating envelopes published in these guidelines are qualified for a maximum superheat of 10K and 20 K.

**NOTE: For more information about vapour injection, as well as the way to handle it, please refer to Technical Information C7.4.3 "Vapour injection Scroll compressors for heat pumps".**

#### **2.4.4 Design features**

The variable speed scroll ZHW has a number of design features that improve efficiency and reliability. A HVE valve is part of ZHW models for higher performance at high pressure ratio. This valve prevents reverse rotation during shutdown; however, some shutdown sound may occur.

All the ZHW models are equipped with a positive displacement oil pump to ensure an adequate supply of oil to the bearing system throughout the operating speed range of 900 to 7000 rpm.

The motor in the variable speed scroll is a three-phase, brushless permanent magnet (BPM) design coupled with a rotor embedded with high energy magnets. The input voltage is a series of +DC pulses, spaced in time to create an alternating current frequency.

## 2.4.5 Dimensions

The external dimensions of ZHW compressors are shown in **Figure 8** below.

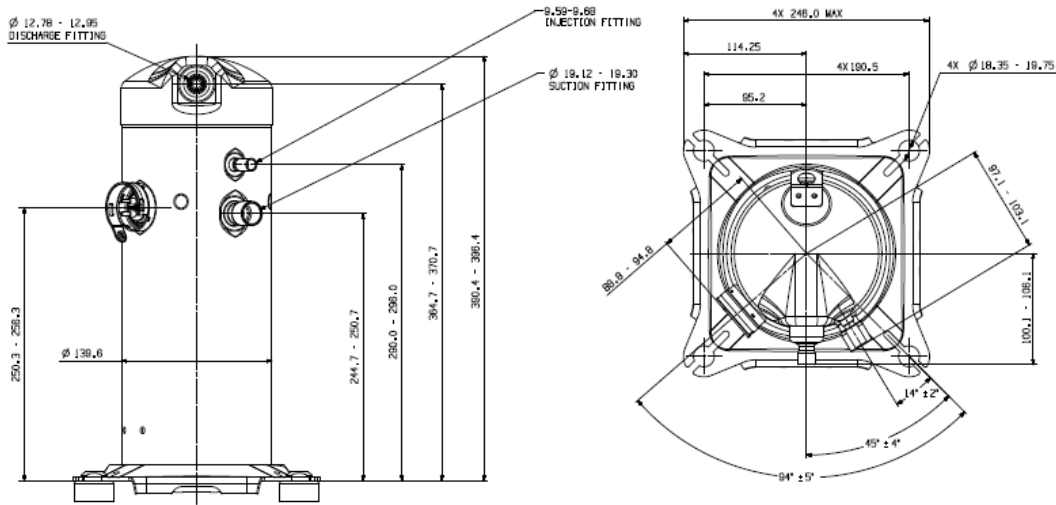

**Figure 8: ZHW015 & ZHW030 external dimensions**

## 2.4.6 Oil recovery

For internal compressor lubrication, an oil recovery cycle is required for continuous operation of over two hours below 1800 rpm. This cycle is accomplished by ramping the compressor speed up to a higher speed to increase the refrigerant flow rate to flush or sweep oil back to the compressor. For this it is requested to ramp up the compressor speed up to 3600 rpm for 5 minutes.

For oil return the exact parameters for an oil recovery cycle need to be evaluated for each system by oil return tests, as they may differ depending on system application. Please contact and review with Application Engineering at Emerson for any desired changes to this oil recovery cycle requirement.

## 3 Installation



### WARNING

**High pressure! Injury to skin and eyes possible!** Be careful when opening connections on a pressurized item.

### 3.1 Compressor and drive handling



### WARNING

**Static electricity! Personal injuries!** Personnel handling the drives in a manufacturing plant environment should guard against static electricity by using the appropriate equipment - antistatic wrist straps and mats.

#### 3.1.1 Compressor transport and storage



### WARNING

**Risk of collapse! Personal injuries!** Move compressors only with appropriate mechanical or handling equipment according to weight. Keep in the upright position. Respect stacking loads according to **Figure 9**. Check the tilting stability and if needed take action to ensure the stability of the stacked loads. Do not stack single boxes on top of each other. Keep the packaging dry at all times.



Respect the maximum number of identical packages which may be stacked on one another, where "n" is the limiting number:

- **Transport: n = 1**
- **Storage: n = 2**

Figure 9: Maximum stacking loads for transport and storage

The compressor tilt angle should not be more than 30° during transport and handling. This will prevent oil from exiting through the suction stub. A tilt angle of maximum 45° is allowed for a very short time. Tilting the compressor more than 45° might affect its lubrication at start-up.

#### 3.1.2 Compressor positioning and securing



### IMPORTANT

**Handling damage! Compressor malfunction!** Only use the lifting eyes whenever the compressor requires positioning. Using discharge or suction connections for lifting may cause damage or leaks.

The compressor should be kept vertical during handling.

The discharge connection plug should be removed first before pulling the suction connection plug to allow the dry air pressure inside the compressor to escape. Pulling the plugs in this sequence prevents oil mist from coating the suction tube making brazing difficult. The copper-coated steel suction tube should be cleaned before brazing.

The compressor plugs must be removed as late as possible before brazing so that the air humidity does not affect the oil characteristics.

As oil might spill out of the suction connection located low on the shell, the suction connection plug must be left in place until the compressor is set into the unit.

No object, eg, a swaging tool should be inserted deeper than 51 mm into the suction tube as it might damage the suction screen and motor.

#### 3.1.3 Installation location

The package (compressor and drive) is capable of operating correctly at altitudes up to 2000 meters.

Ensure that the compressor and drive are installed on a solid level base. If required by the application, the compressor tilt angle during operation should not be more than 15° to allow adequate lubrication.

### 3.1.4 Compressor mounting parts

The compressors are designed to be mounted on vibration absorber grommets (part of the standard delivery). The grommets dampen the start-up surge of the compressor and minimise sound and vibration transmission to the compressor base during operation. The metal sleeve inside is a guide designed to hold the grommet in place. It is not designed as a load-bearing member, and application of excessive torque to the bolts can crush the sleeve. Its inner diameter is approximately 8.5 mm to suit a M8 screw. The mounting torque should be  $13 \pm 1$  Nm. It is critically important that the grommet is not compressed.

**NOTE:** For more information please refer to Technical Information C7.11.2 "Scroll Mounting Parts".



Figure 10: Rubber mounting part with sleeve

### 3.2 Compressor brazing procedure

#### IMPORTANT

**Blockage! Compressor breakdown!** Maintain a flow of oxygen-free nitrogen through the system at very low pressure during brazing. Nitrogen displaces the air and prevents the formation of copper oxides in the system. If allowed to form, the copper oxide material can later be swept through the system and block screens such as those protecting capillary tubes, thermal expansion valves, and accumulator oil return holes.

**Contamination or moisture! Bearing failure!** Do not remove the plugs until the compressor is set into the unit. This minimises any entry of contaminants and moisture.

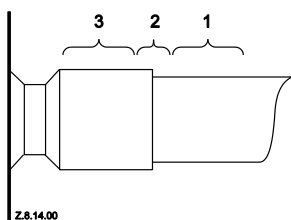

Figure 11: Suction tube connecting areas

Copeland Scroll compressors have copper-plated steel suction, injection and discharge tubes. These tubes are far more robust and less prone to leaks than copper tubes. Due to the different thermal properties of steel and copper, brazing procedures may have to be changed from those commonly used.

Refer to **Figure 11** and procedure below for the brazing of the suction, discharge and injection lines to a Scroll compressor.

- The copper-coated steel tubes on scroll compressors can be brazed in approximately the same manner as any copper tube.
- Recommended brazing materials: any silfos material is recommended, preferably with a minimum of 5% silver. However, 0% silver is acceptable.
- Be sure tube fitting inner diameter and tube outer diameter are clean prior to assembly.
- Using a double-tipped torch, apply heat in area 1.
- As the tube approaches brazing temperature, move the torch flame to area 2.
- Heat area 2 until braze temperature is attained, moving the torch up and down and rotating around the tube as necessary to heat the tube evenly. Add braze material to the joint while moving the torch around the joint to flow braze material around the circumference.
- After the braze material flows around the joint, move the torch to heat area 3. This will draw the braze material down into the joint. The time spent heating area 3 should be minimal.
- As with any brazed joint, overheating may be detrimental to the final result.

## To disconnect:

- Heat joint areas 2 and 3 slowly and uniformly until the braze material softens and the tube can be pulled out of the fitting.

## To reconnect:

- Recommended brazing materials: Silfos with minimum 5% silver or silver braze used on other compressors. Due to the different thermal properties of steel and copper, brazing procedures may have to be changed from those commonly used.

**NOTE:** Since the discharge stub contains a check valve, care must be taken not to overheat it to prevent brazing material from flowing into it.

**NOTE:** Since the injection tubing design of the ZHW015/ZHW030 compressors includes some O-rings, a wet rag or any other suitable heat protection must be used when brazing the injection line to the compressor.

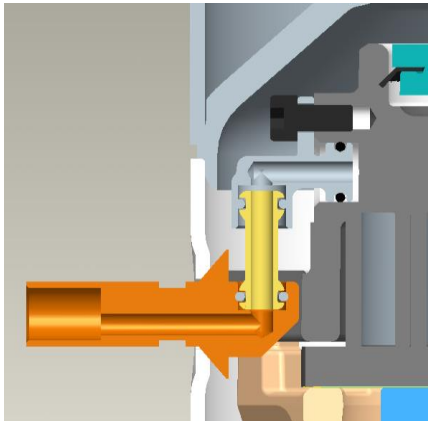

Figure 12: Zoom on the O-rings composing the injection in compressor models ZHW015 & ZHW030

## 3.3 Accumulators



### CAUTION

**Inadequate lubrication! Bearing and moving parts destruction!** Minimise liquid refrigerant returning to the compressor. Too much refrigerant dilutes the oil. Liquid refrigerant can wash the oil off the bearings and moving parts leading to overheating and compressor failure.

Due to Copeland Scrolls inherent ability to handle liquid refrigerant in flooded start and defrost cycle operation, an accumulator is not required for durability in most systems. However, large volumes of liquid refrigerant repeatedly flooding back to the compressor during normal off cycles, or excessive liquid refrigerant flooding back during defrost or varying loads can dilute the oil, no matter what the system charge is. As a result, bearings and moving parts will be inadequately lubricated and wear may occur.

To determine if the accumulator can be removed, dedicated tests must be carried out to ensure that excessive liquid does not flood back to the compressor during defrost or varying loads. The defrost test must be done at an outdoor ambient temperature of around 0°C in a high relative humidity environment. Liquid floodback must be monitored during reversing valve operation, especially when coming out of defrost. Excessive floodback occurs when the sump temperature drops below the safe operation line shown in **Figure 13**.

If an accumulator has to be used, the oil-return orifice should be from 1 to 1.4 mm in diameter depending on compressor size and compressor floodback results. A large-area protective screen no finer than 30 x 30 mesh (0.6 mm openings) is required to protect this small orifice from plugging with system debris. Tests have shown that a small screen with a fine mesh can easily become plugged causing oil starvation to the compressor bearings.

The size of the accumulator depends upon the operating range of the system and the amount of sub-cooling and subsequent head pressure allowed by the refrigerant control. System modelling indicates that heat pumps that operate down to and below -18°C will require an accumulator that can hold around 70% to 75% of the system charge.

The behaviour of the accumulator and its ability to prevent liquid slugging and subsequent oil pump-out at the beginning and end of the defrost cycle should be assessed during system development. This will require special accumulators and compressors with sight tubes for monitoring refrigerant and oil levels.

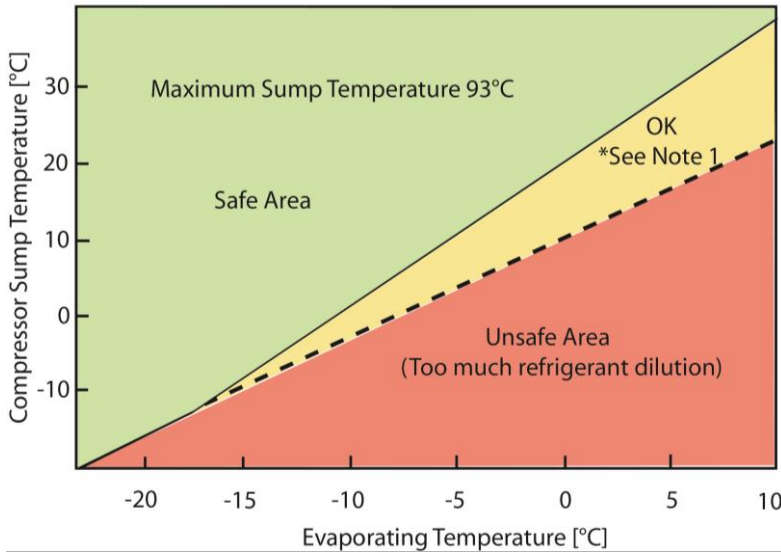

Figure 13: Dilution chart for transient operation (tb = bottom shell temperature; te = evaporating temperature)

**Note 1: Low load operation may be acceptable in the yellow marked area. Please contact the Application Engineering department at Emerson.**

### 3.4 Screens



**CAUTION**

**Screen blocking! Compressor breakdown!** Use screens with at least 0.6 mm openings.

The use of screens finer than 30 x 30 meshes (0.6 mm openings) anywhere in the system should be avoided with these compressors. Field experience has shown that finer mesh screens used to protect thermal expansion valves, capillary tubes or accumulators can become temporarily or permanently plugged with normal system debris and block the flow of either oil or refrigerant to the compressor. Such blockage can result in compressor failure.

### 3.5 Mufflers

External mufflers, normally applied to piston compressors in the past, may not be required for Copeland Scroll compressors.

Individual system tests should be performed to verify acceptability of sound performance. If adequate attenuation is not achieved, use a muffler with a larger cross-sectional area to inlet area ratio. A ratio of 20:1 to 30:1 is recommended.

A hollow shell muffler will work quite well. Locate the muffler at minimum 15 to maximum 45 cm from the compressor for the most effective operation. The further the muffler is placed from the compressor within these ranges, the more effective. Choose a muffler with a length of 10 to 15 cm.

### 3.6 Sound shell

The sound power is an important criterion in the development of heating units. Information about the nominal sound power and the rating conditions of various Copeland compressor models can be found in Copeland brand products Select software at [www.climate.emerson.com/en-gb](http://www.climate.emerson.com/en-gb).

In order to decrease the sound power of the compressor, Emerson offers optional sound covers suitable for a large range of Scroll products including ZHW compressors.

Note that the use of sound cover reduces the compressor operating envelopes.

Safety instructions  
Product description  
Installation  
Electrical connection  
Starting up & operation  
Maintenance & repair  
Troubleshooting  
Dismantling & disposal  
References



**NOTE:** For more information please refer to Technical Information C7.11.4 "Sound shell installation instructions for Copeland Scroll™ compressors".

### 3.7 Reversing valves

A variable speed scroll brings a significant benefit during the defrost cycle. By taking advantage of the higher speeds and flow rates, the defrost time will typically be shorter than in a fixed-speed compressor system, which will reduce the time electric resistance heat is used during the defrost cycle.

Reversing valve sizing must be within the guidelines of the valve manufacturer. Required pressure drop to ensure valve shifting must be measured throughout the operating range of the unit and compared to the valve manufacturer's data. Conditions that generate low flow rates and low pressure drop across the valve can result in a valve not shifting.

This can result in a condition where the compressor appears to be not pumping, ie, balanced pressure. It can also produce elevated compressor sound levels. During a defrost cycle, when the reversing valve abruptly changes the refrigerant flow direction, the suction and discharge pressures will go outside of the operating envelope. The condition will usually cross the diagonal line representing the lower right-hand side corner of the envelope. The sound that the compressor makes during this transition period is normal, and the duration of the sound will depend on the coil volume, outdoor ambient and system charge.

Since Copeland Scroll compressors have a very high volumetric efficiency their displacements are lower than those of equivalent capacity reciprocating compressors. As a result, Emerson recommends that the capacity rating on reversing valves be no more than 1.5 to 2 times the nominal capacity of the compressor in order to ensure proper operation of the reversing valve under all operating conditions.

The reversing solenoid valve should be wired so that the valve does not reverse when the system is shut off by the operating thermostat in the heating or cooling mode. If the valve is allowed to reverse at system shut off, suction and discharge pressures are reversed to the compressor. This results in a condition of system pressures equalising through the compressor which can cause the compressor to slowly rotate until the pressures equalise. This condition does not affect compressor durability but can cause unexpected sound after the compressor is turned off.

The preferred method of mitigating defrost sound for the variable speed scroll is to signal the drive to go to low speed when a defrost signal is received from the system. When low speed is reached, the reversing valve is signalled to change positions. The system should be allowed to operate for 30 to 60 seconds at low speed for the suction and discharge pressures to stabilize. After 30 to 60 seconds the compressor speed should be increased to some predetermined speed based on the outdoor ambient temperature. The routine at the end of the defrost cycle should be similar. The above method is a suggestion and the system design engineer should develop the routine that best mitigates compressor sound during defrost while ensuring a defrost cycle that is as short as possible.

### 3.8 Sound and vibrations

Proper pipe design must be taken into consideration when connecting a scroll compressor to a system.

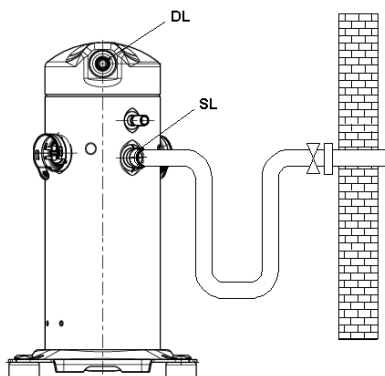

Figure 14: Suction tube design

A scroll compressor makes both a rocking and twisting motion and enough flexibility must be provided in the pipe-lines to allow starting, stopping and steady state running of the compressor without transmitting excessive stress into any line attached to the unit. In a split system, the most important goal is to ensure minimal vibration in all directions to avoid transmitting vibrations to the structure to which the lines are fastened.

Under some conditions, the Copeland Scroll has a normal starting rotational motion that can transmit a transient noise along the lines. This may be particularly pronounced in compressors using a three-phase motor due to their inherently higher starting torque. This phenomenon, like the one described previously, can easily be avoided by using standard line isolation techniques.

Since the variable speed scroll has a broad running frequency range (15-120 Hz), it is almost impossible to avoid all of the natural frequencies that may exist in the system piping. The system designer must carefully evaluate these resonant frequency conditions and either a) avoid them by not allowing the compressor speed to align with the resonant frequency, or b) evaluate the risk and life of the piping system when the compressor is allowed to run at frequencies that are coincident with the natural frequencies of the piping system. If option "b" is chosen, strain gauging of the system piping is required.

The sound level of a system is the result of design, quality and application. Scroll compressors sound power levels generally increase with the compressor model capacity and the condition pressure ratio. For variable speed scroll compressors, they also and mainly increase with the compressor speed.

Safety  
instructions

Product  
description

Installation

Electrical  
connection

Starting up &  
operation

Maintenance &  
repair

Trouble-  
shooting

Dismantling &  
disposal

References

## 4 Electrical connection

---

### 4.1 Recommendations for the drive

The Emerson EV2 drive assembly includes the main drive board with heat sink on the back and the EMI filter. Additionally, one external PFC choke must be used. The choke has to be mounted on the cabinet metal sheet of the unit.

For three-phase drives in a residential area, an additional capacitor board, 3 PFC chokes and an external EMI filter must be used. The chokes have to be mounted on the cabinet metal sheet of the unit.

### 4.2 General recommendations

Before connecting the drive to the power network, make sure that all the cables to and from the drive and to the compressor are correctly connected and that the supply voltage, phases and frequency match the drive nameplate data.

Wiring should remain physically separated to minimize the introduction of electrical noise.

### 4.3 Electrical installation



#### WARNING

#### Electrical hazard! Serious personal injuries and/or system breakdown!

The compressor must always have the green ground wire attached to the moulded plug terminal fence. The other end of the green wire must be connected to the appropriate ground terminal on the drive.



#### CAUTION

**High voltage! Drive damage!** The unit **contactor** must be installed upstream of the drive, not between the drive and the compressor. Nor should a disconnected switch be installed between the drive and the compressor. Major faults and irreversible damage to the drive could occur if the drive output is open-circuit while the compressor is running.



#### CAUTION

**High-pressure refrigerant leakage! Fusite™ damage!** The moulded plugs are simply plugged; they do not have any kind of thread. To remove them safely, pull the plugs by hand; do not use any tool; do not turn or rotate them. Removing the moulded plugs with force could damage the fusite and cause refrigerant leakage and physical injury. The refrigerant charge of the system must be recovered before removing the moulded plugs.

The cable supplying electrical power from the drive to the compressor has a moulded plug at the compressor end (see **Figure 15**). It has an Ingress Protection (IP) 54 rating. It is unshielded and should not exceed 1.7 m in length.



Figure 15: Moulded plug used for cable connection to the compressor

#### 4.4 Wiring diagrams

Recommended wiring diagrams are shown in **Figures 16 & 17** hereunder.

**NOTE:** A K2 contactor is optional. The EV2 drive has a lockout function (there are specific faults that will cause the drive to lockout after 10 consecutive occurrences - check the Application Engineering bulletin of the drive for these faults) which requests a power cycle to reset the drive. If the lockout is to be reset automatically by the system controller, then a K2 contactor is needed.

**NOTE:** An RCD Type B is needed. It can also protect against a DC current leakage.

**NOTE:** For recommendations about the EMC, please refer to the drive guideline.

For the **single-phase package** of ZHW, the following circuit diagrams can be used:

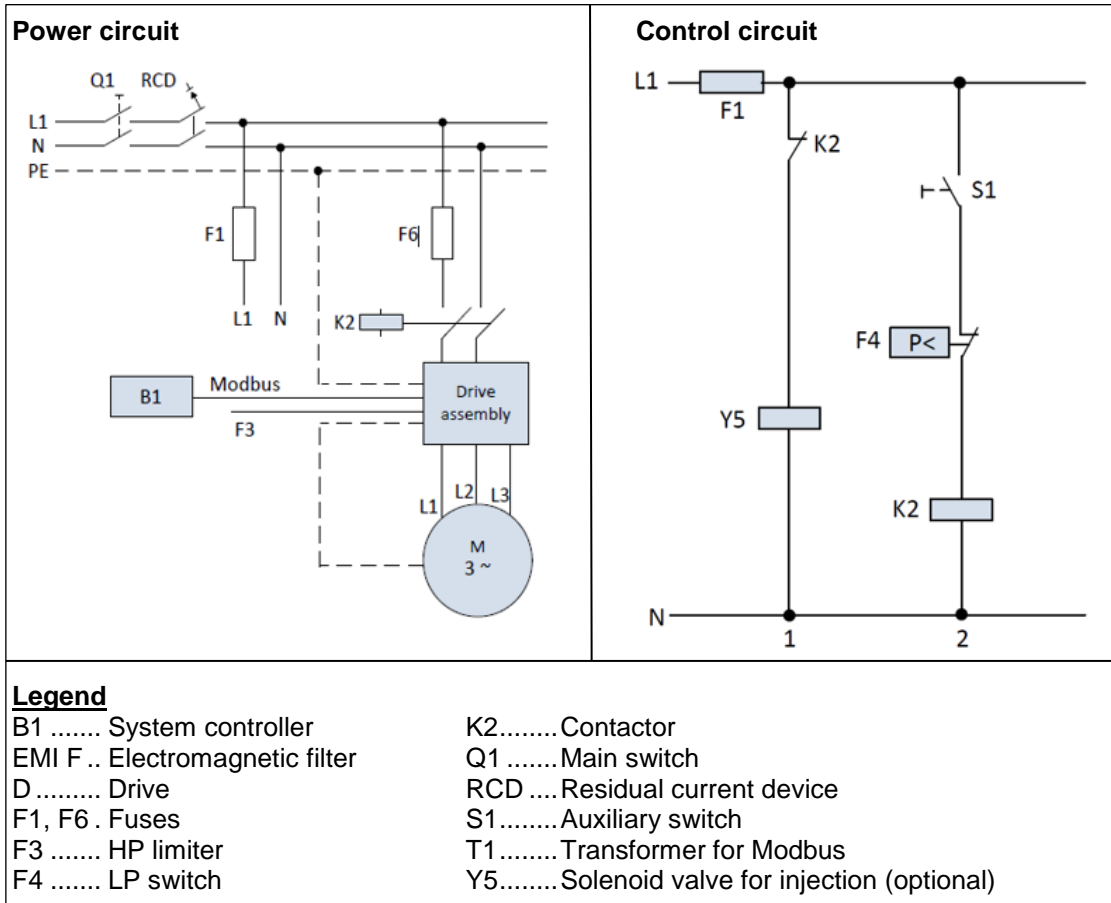

Figure 16: Wiring diagram for ZHW with single-phase drives

For the **three-phase package** of ZHW, the following circuit diagrams can be used:

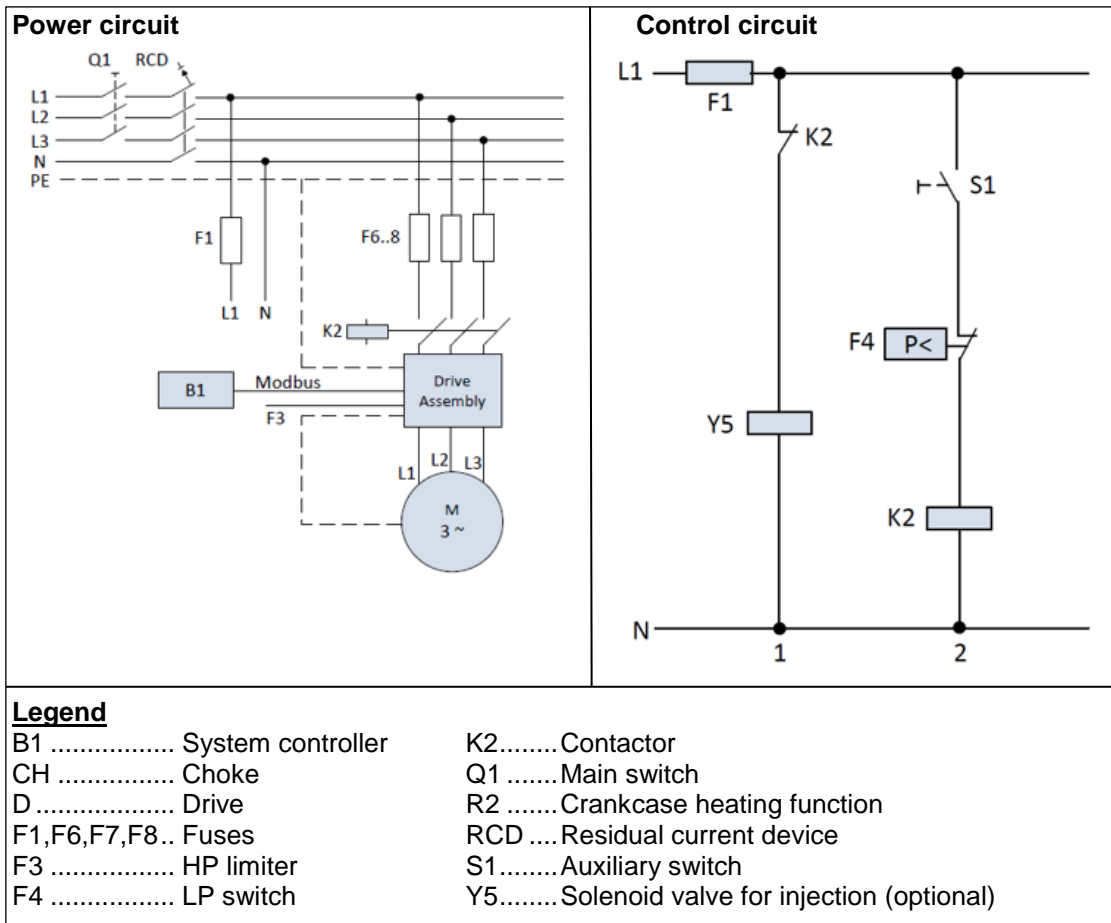

Figure 17: Wiring diagram for ZHW with three-phase drives

#### 4.4.1 Motor windings

ZHW compressors feature a three-phase brushless permanent magnet motor. It is exactly the same whether the drive supply is single-phase or three-phase. The motor is connected in star.

The motor insulation material is class "F" (maximum allowable operating temperatures 155°C according to IEC 34-1 or DIN 57530).

#### 4.4.2 Protection devices

Fuses must be installed before the drive. The selection of fuses has to be carried out according to VDE 0635, DIN 57635, EC 269-1 or EN 60-269-1.

#### 4.4.3 Crankcase heating function



#### CAUTION

**Motor overheating! Compressor damage!** The crankcase heating function must not be energized when the system is in a vacuum or if there is no refrigerant charge in the system. The system low pressure cut-out control can be used as an indicator of the presence of refrigerant charge.

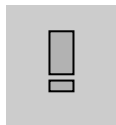

#### IMPORTANT

**Oil dilution! Bearing malfunction!** Follow the off-cycle migration statement described below for long term reliability and to minimize nuisance associated with flooded start conditions.

Contrary to the standard fixed-speed Copeland Scroll compressors, the ZHW models do not require any optional external crankcase heater to be mounted on the compressor.

Instead, the drive EV2 has a programmable feature that will utilize the motor windings to provide up to 50 Watts DC of heating to serve as a crankcase heater.

The crankcase heating function activation is recommended when the system charge exceeds the refrigerant charge limit indicated in **Table 5** below:

Compressor	Refrigerant charge limit
ZHW015P2 / ZHW030P2	3.6 kg

**Table 5: Refrigerant charge limit**

If this function is required and no off-cycle migration testing across the range of expected cold and hot sources temperatures is performed, the crankcase heating function must always be powered to 50 Watts when the compressor is "Off".

To use less than 50 Watts, off-cycle migration testing must be performed. To perform migration testing, a compressor fitted with a sight-tube showing the oil level and any accumulation of liquid in the compressor is required and can be ordered from Emerson. The pass criterion is a liquid level in the compressor that is not higher than 30 millimetres above the normal oil level at all expected cold and hot sources conditions.

**NOTE: At first start, the crankcase heating function must be turned on a minimum of 12 hours prior to starting the compressor.**

## 4.5 Pressure safety controls

### 4.5.1 High-pressure protection

The high-pressure protection should be installed according to EN 378. The high-pressure cut-out limiter can be connected to the EV2 drive through the connector CN610 (see **Figures 16 & 17**). The output is a 3.3VDC signal. Normally the high-pressure cut-out limiter must be closed. If the limiter is open, the drive will not operate.

### 4.5.2 Low-pressure protection

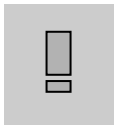

#### IMPORTANT

**Loss of system charge and lubrication! Bearing malfunction and compressor breakdown!** A low-pressure control is highly recommended. Do not bridge or by-pass the low-pressure limiter.

Heat pumps in some geographical areas have to operate at low evaporating pressure because of the low ambient temperatures, sometimes combined with a high level of relative humidity. Good evaporator sizing and adequate defrost strategy control should prevent the system from operating outside the operating envelope published by Emerson, whatever the climatic conditions and the heating demand.

However, in some extreme cases – such as loss of system charge, extreme heat transfer restriction at the evaporator, any defect or blocked flow control component (expansion valve, screens, etc.) – the evaporating conditions may be such that the compressor tends to operate outside the Emerson operating envelope limits. All those conditions may result in compressor failure.

Therefore, Emerson strongly recommends the installation of a low-pressure limiter in the suction line to stop the compressor when it operates outside the published envelope limits.

## 4.6 Discharge gas temperature protection

A good system control should prevent the system from operating outside the published operating envelope and acceptable superheat range, whatever the climatic conditions and the heating demand. However, under some extreme operating conditions (such as loss of charge or improper control operation), the internal discharge gas temperature reached can cause compressor damage. To guarantee positive compressor protection, discharge gas temperature protection is required for any application with Copeland brand compressors. This protection must not be used as an operating envelope controller but as a safety device.

ZHW compressors do not have an internal discharge temperature protection. In order for the drive to operate properly a thermistor must be attached to the compressor discharge line less than 12 cm from the compressor discharge fitting. For best response the sensor must be insulated and placed in a sleeve braced on the discharge pipe (see **Figure 18**). If you use thermal compound to improve the heat transfer from sleeve to sensor, make sure it is approved for these temperatures.

Also protect the sensor from being removed from its position by transport; vibration or any other incident. Refer to the operating map for maximum operating discharge line temperatures.

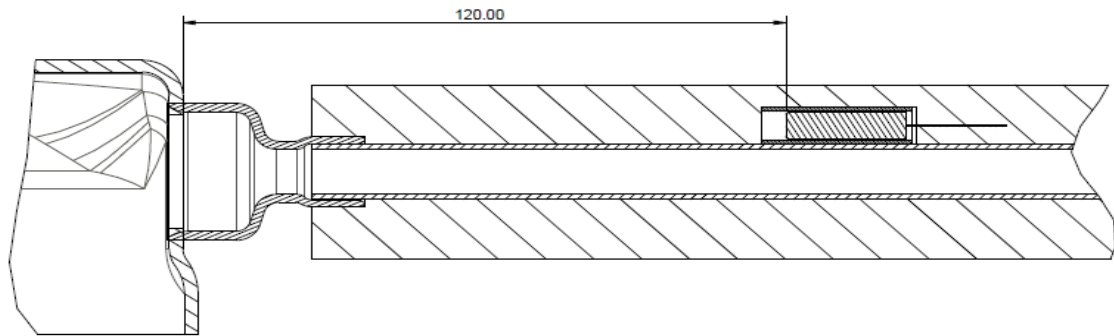

Figure 18: Discharge temperature sensor mounting

## 4.7 High-potential testing



### WARNING

**Conductor cables! Electrical shock!** Shut off power supply before high-potential testing.



### CAUTION

**Internal arcing! Motor destruction!** Do not carry out high-voltage or insulation tests if the compressor housing is under vacuum.

Since high-voltage tests lead to premature ageing of the winding insulation further additional tests of that nature are not recommended. If it has to be done for any reason, please contact the Application Engineering department at Emerson for high-potential testing procedure and set-up.

## 5 Starting up & operation



**WARNING**  
**Diesel effect! Compressor destruction!** The mixture of air and oil at high temperature can lead to an explosion. Avoid operating with air.

### 5.1 Strength pressure test



**WARNING**  
**High pressure! Personal injuries!** Consider personal safety requirements and refer to test pressures prior to test.



**WARNING**  
**System explosion! Personal injuries! DO NOT USE** other industrial gases.



**CAUTION**  
**System contamination! Bearing malfunction!** Use only dry nitrogen for pressure testing.

The compressor has been strength-tested in the Emerson factory. As the compressor complies with EN 60335-2-34, it is not necessary for the customer to strength-test the compressor.

Since it is not possible to isolate the compressor from the rest of the system, system strength pressure testing according to EN 378-2 should be carried out in two steps at two different test pressures, the high-side test pressure HPT and the low-side test pressure LPT:

- First, apply for a short time the HPT in the high-pressure section of the system up to the compressor discharge stub. The compressor check valve automatically closes to isolate the low-pressure side. During that test, make sure that the low-pressure side of the system does not exceed the compressor maximum standstill pressure, ie, the compressor low side PS.
- Then, test the low-pressure section of the system by applying the LPT not exceeding the low side PS.

### 5.2 Compressor tightness test



**WARNING**  
**High pressure! Personal injuries!** Consider personal safety requirements and refer to test pressures prior to test.



**WARNING**  
**System explosion! Personal injuries! DO NOT USE** other industrial gases.



**CAUTION**  
**System contamination! Bearing malfunction!** Use only dry nitrogen or helium for leak testing.

The compressor has been leak-tested in the Emerson factory. As the compressor complies with EN 60335-2-34, it is not necessary for the customer to leak-test the compressor.

If using dry air do not include the compressor in the leak test – isolate it first. Never add refrigerant to the test gas (as leak indicator).

### 5.3 Preliminary checks – Pre-starting

Discuss details of the installation with the installer. If possible, obtain drawings, wiring diagrams, etc. It is ideal to use a check-list but always check the following:

- Visual check of the electrics, wiring, fuses etc.
- Visual check of the plant for leaks, loose fittings such as TXV bulbs etc.
- Compressor oil level
- Calibration of HP & LP limiters and any pressure actuated valves
- Check setting and operation of all safety features and protection devices
- All valves in the correct running position
- Pressure and compound gauges fitted



- Correctly charged with refrigerant
- Compressor electrical isolator location & position

## 5.4 Charging procedure



### CAUTION

**Low suction pressure operation! Compressor damage!** Do not operate with a restricted suction. Do not operate with the low-pressure cut-out bridged. Do not operate the compressor at pressures not allowed by the operating envelope. Allowing the suction pressure to drop below the envelope limit for more than a few seconds may overheat scrolls and cause early drive bearing and moving parts damage.

The system should be liquid-charged through the liquid-receiver shut-off valve or through a valve in the liquid line. The use of a filter drier in the charging line is highly recommended. Since scrolls have discharge check valves, systems should be liquid-charged on both the high and low sides simultaneously to ensure a positive refrigerant pressure is present in the compressor before it runs. The majority of the charge should be placed in the high side of the system to prevent bearing washout during first-time start on the assembly line.

## 5.5 Run-in time

Scroll compressors exhibit a slight decrease in input power during the initial running period. Published performance ratings are based on calorimeter testing which is carried out after run-in. Therefore users should be aware that before the performance specified by EN 12900 is achieved the compressor needs to be run in.

## 5.6 Initial start-up



### CAUTION

**Oil dilution! Bearing and moving parts malfunction!** It is important to ensure that new compressors are not subjected to liquid abuse. Turn the crankcase heating on 12 hours before starting the compressor.



### CAUTION

**High discharge pressure operation! Compressor damage!** Do not use compressor to test opening set point of high-pressure limiter. Bearings and moving parts are susceptible to damage before they have had several hours of normal running in.

Liquid and high-pressure loads could be detrimental to new bearings. It is therefore important to ensure that new compressors are not subjected to liquid abuse and high-pressure run tests. It is not good practice to use the compressor to test the high-pressure switch function on the production line. Switch function can be tested with nitrogen prior to installation and wiring can be checked by disconnecting the high-pressure switch during the run test.

## 5.7 Starting and stopping routine

The drive controls the starting and stopping routine of the variable speed scroll. This routine allows for soft starting and controlled stopping, an advantage over traditional on-off control of fixed capacity units. For more information about this topic please consult Application Engineering bulletins AE-1405 (1 phase) or AE-1411(3 phase).

## 5.8 Starting sound

During the very brief start-up, a clicking sound is audible, resulting from initial contacting of the spirals and is normal. Due to the design of the Copeland Scroll compressors, the internal compression components always start unloaded even if system pressures are not balanced. In addition, since internal compressor pressures are always balanced at start-up, low-voltage starting characteristics are excellent for Copeland Scroll compressors.

## 5.9 Deep vacuum operation



### CAUTION

**Vacuum operation! Compressor damage!** Copeland Scroll compressors should never be used to evacuate the refrigeration circuit of the heat pump.

The scroll compressor can be used to pump down refrigerant in a unit as long as the pressures remain within the operating envelope. Low suction pressures will result in overheating of the scrolls and permanent damage to the compressor drive bearing and moving parts.

## 5.10 Shell temperature

The top shell and discharge line can briefly but repeatedly reach temperatures above 177°C if the compressor cycles on its internal protection devices. This only happens under rare circumstances and can be caused by the failure of system components such as the condenser or evaporator fan or loss of charge and depends upon the type of expansion control. Care must be taken to ensure that wiring or other materials that could be damaged by these temperatures do not come in contact with the shell.

## 5.11 Pumpdown cycle

A pumpdown cycle for control of refrigerant migration may be used in conjunction with the crankcase heating function when the compressor is located so that cold air blowing over the compressor makes the crankcase heating function ineffective.

**If a pumpdown cycle is used, a separate external check valve must be added.** The scroll discharge check valve is designed to stop extended reverse rotation and prevent high-pressure gas from leaking rapidly into the low side after shut-off. The check valve will in some cases leak causing the scroll compressor to recycle more frequently. Repeated short-cycling of this nature can result in a low oil situation and consequent damage to the compressor. The low-pressure control differential has to be reviewed since a relatively large volume of gas will re-expand from the high side of the compressor into the low side after shutdown.

**For pressure control setting, never set the low-pressure control to shut off outside of the operating envelope. To prevent the compressor from running into problems during such faults as loss of charge or partial blockage, the control should not be set lower than the minimum suction pressure allowed by the operating envelope.**

## 5.12 Minimum run time

Emerson recommends a maximum of 10 starts per hour. There is no minimum off time because scroll compressors start unloaded, even if the system has unbalanced pressures. The most critical consideration is the minimum run time required to return oil to the compressor after start-up. To establish the minimum run time, obtain a sample compressor equipped with a sight tube (available from Emerson) and install it in a system with the longest connecting lines that are approved for the system. The minimum on time becomes the time required for oil lost during compressor start-up to return to the compressor sump and restore a minimal oil level that will ensure oil pick-up through the crankshaft. Cycling the compressor for a shorter period than this, for instance to maintain very tight temperature control, will result in progressive loss of oil and damage to the compressor.

## 5.13 Oil level

ZHW compressors are not equipped with any oil sight glass.

During the heat pump development, adequate oil return in any operation should be checked whatever the compressor model. For this purpose, a sample compressor equipped with a sight tube can be ordered from Emerson. Oil return check test recommendations are also available on request from the Application Engineering department at Emerson.

## 6 Maintenance & repair

---

### 6.1 Exchanging the refrigerant

Qualified refrigerants and oils are given in section 2.4.1.

It is not necessary to replace the refrigerant with new unless contamination due to an error such as topping up the system with an incorrect refrigerant is suspected. To verify correct refrigerant composition, a sample can be taken for chemical analysis. A check can be made during shutdown by comparing the refrigerant temperature and pressure using precision measurements at a location in the system where liquid and vapour phases are present and when the temperatures have stabilised.

In the event that the refrigerant needs replacing, the charge should be recovered using a suitable recovery unit.

### 6.2 Replacing a compressor



#### CAUTION

**Inadequate lubrication! Bearing destruction!** Exchange the accumulator after replacing a compressor with a burned out motor. The accumulator oil return orifice or screen may be plugged with debris or may become plugged. This will result in starvation of oil to the new compressor and a second failure.

#### 6.2.1 Compressor replacement

In the case of a motor burnout, the majority of contaminated oil will be removed with the compressor. The rest of the oil will be cleaned through the use of suction and liquid line filter driers. A 100% activated alumina suction line filter drier is recommended but must be removed after 72 hours.

**It is highly recommended that the suction accumulator be replaced if the system contains one.** This is because the accumulator oil return orifice or screen may be plugged with debris or may become plugged shortly after a compressor failure. This will result in starvation of oil to the replacement compressor and a second failure. When a compressor is exchanged in the field, it is possible that a major portion of the oil may still be in the system. While this may not affect the reliability of the replacement compressor, the extra oil will add to rotor drag and increase power usage.

#### 6.2.2 Start-up of a new or replacement compressor

Rapid charging only on the suction side of a scroll-equipped system or condensing unit can occasionally result in a temporary no-start condition for the compressor. The reason for this is that, if the flanks of the compressor happen to be in a sealed position, rapid pressurisation of the low side without opposing high-side pressure can cause the scrolls to seal axially. As a result, until the pressures eventually equalise, the scrolls can be held tightly together preventing rotation. The best way to avoid this situation is to charge on both the high and low sides simultaneously at a rate which does not result in axial loading of the scrolls.

A minimum suction pressure, specified by the published operating envelope, must be maintained during charging. Allowing the suction pressure to drop below that value may overheat the scrolls and cause early drive bearing and moving parts damage. Never install a system in the field and leave it unattended when it has no charge, a holding charge, or with the service valves closed without securely electrically locking out the system. This will prevent unauthorised personnel from accidentally operating the system and potentially ruining the compressor by operating with no refrigerant flow. **Do not start the compressor while the system is in a deep vacuum.** Internal arcing may occur when a Scroll compressor is started in a vacuum causing burnout of the internal lead connections.

6.3 Lubrication and oil removal



**CAUTION**

**Chemical reaction! Compressor destruction!** Do not mix up ester oils with mineral oil and/or alkyl benzene when used with chlorine-free (HFC) refrigerants.

The compressor is supplied with an initial oil charge. The standard oil charge for use with refrigerant R410A is a polyester (POE) lubricant Emkarate RL 32 3MAF. In the field the oil level could be topped up with Mobil EAL Arctic 22 CC if 3MAF is not available. See nameplate for original oil charge shown in litres. A field recharge is from 0.05 to 0.1 litre less.

One disadvantage of POE is that it is far more hygroscopic than mineral oil (see **Figure 19**). Only brief exposure to ambient air is needed for POE to absorb sufficient moisture to make it unacceptable for use in a refrigeration system. Since POE holds moisture more readily than mineral oil it is more difficult to remove it through the use of vacuum. Compressors supplied by Emerson contain oil with low moisture content, and it may rise during the system assembling process. Therefore, it is recommended that a properly sized filter-drier is installed in all POE systems. This will maintain the moisture level in the oil to less than 50 ppm. If oil is charged into a system, it is recommended to use POE with moisture content no higher than 50 ppm.

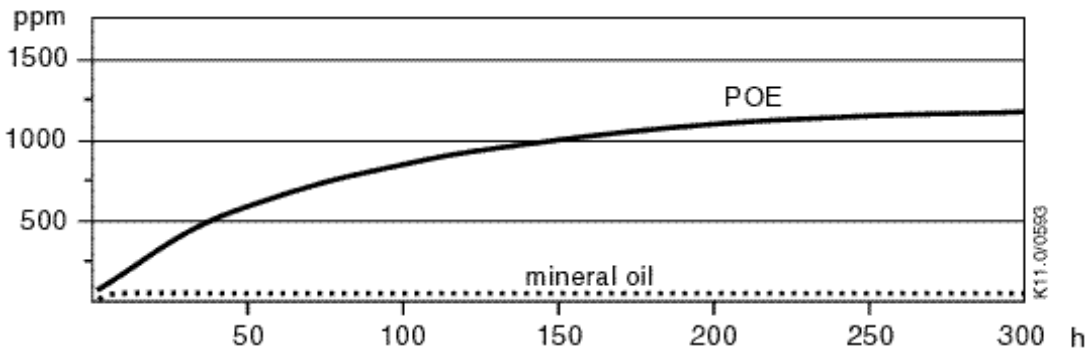

Figure 19: Absorption of moisture in ester oil in comparison to mineral oil in ppm by weight at 25°C and 50% relative humidity (h=hours)

If the moisture content of the oil in a refrigeration system reaches unacceptably high levels, corrosion and copper plating may occur. The system should be evacuated down to 0.3 mbar or lower. If there is uncertainty as to the moisture content in the system, an oil sample should be taken and tested for moisture. Sight glass/moisture indicators currently available can be used with the HFC refrigerants and lubricants; however, the moisture indicator will just show the moisture presence in the refrigerant. The actual moisture level of POE would be higher than the sight glass indicates. This is due to the high hygroscopicity of the POE oil. To determine the actual moisture content of the lubricant, samples have to be taken from the system and analysed.

6.4 Oil additives

Although Emerson cannot comment on any specific product, from our own testing and past experience, we do not recommend the use of any additives to reduce compressor bearing losses or for any other purpose. Furthermore, the long term chemical stability of any additive in the presence of refrigerant, low and high temperatures, and materials commonly found in refrigeration systems is complex and difficult to evaluate without rigorously controlled chemical laboratory testing. The use of additives without adequate testing may result in malfunction or premature failure of components in the system and, in specific cases, in voiding the warranty on the component.

Safety instructions  
 Product description  
 Installation  
 Electrical connection  
 Starting up & operation  
**Maintenance & repair**  
 Troubleshooting  
 Dismantling & disposal  
 References

## 6.5 Unbrazing system components



### **WARNING**

**Explosive flame! Burning!** Oil-refrigerant mixtures are highly flammable. Remove all the refrigerant before opening the system. Avoid working with an unshielded flame in a refrigerant charged system.

Before opening up a system it is important to remove all the refrigerant from both the high and low sides of the system. If the refrigerant charge is removed from a scroll-equipped unit from the high side only, it is possible for the scrolls to seal, preventing pressure equalization through the compressor. This may leave the low side shell and suction line tubing pressurized. If a brazing torch is then applied to the low side while the low side shell and suction line contain pressure, the pressurized refrigerant and oil mixture could ignite when it escapes and contacts the brazing flame. To prevent this occurrence, it is important to check both the high and low sides with manifold gauges before unbrazing. Instructions should be provided in appropriate product literature and assembly (line repair) areas. If compressor removal is required, the compressor should be cut out of system rather than unbrazed.

7 Troubleshooting

Most in-warranty electrical failures are the result of mechanical problems (particles in the oil, liquid refrigerant in the oil, etc.) and most mechanical problems are the result of system problems. Unless the reason for the failure is found, replacing the compressor will probably lead to another compressor failure.

If the compressor fails to start and run properly, it is important that the compressor be tested to determine its condition. It is possible that electrical components may be defective, the protector may be open, or a safety device may be tripped. The most common compressor problems encountered in the field are listed below.



**WARNING**

**Electrical connections! Electrical shock!** Before attempting any electrical troubleshooting, make sure all grounds are connected and secure and there is ground continuity throughout the compressor system. Also ensure the compressor system is correctly grounded to the power supply. If you are not a qualified service person familiar with electrical troubleshooting techniques, **DO NOT PROCEED** until a qualified service person is available.

Condition	Cause	Corrective action
The Scroll compressor does not run, instead a buzz sound can be heard	Wired incorrectly	Check the power supply on the compressor terminals if there is voltage measured. Trace the wiring diagram to see where the circuit is interrupted.
	Low supply voltage	If the voltage falls below 90% of the nameplate voltage, the motor may develop insufficient torque. Make sure the compressor is supplied with rated nominal voltage.
	Defective capacitor or relay	For a single-phase motor, a defective capacitor or relay may prevent the compressor from starting. Check these components by substituting “a known-to-be-good” component if available. Make sure that the capacitors are electrically discharged before checking.
	Shorted or grounded motor windings	Check the motor for ground by means of a continuity check between the terminals. If grounded replace compressor.
	Internal compressor mechanical damage	<ul style="list-style-type: none"> <li>▪ Refrigerant migration: When the compressor is switched off for a long period refrigerant can condense in the crankcase. If the compressor body is colder than the evaporator, refrigerant will move from the evaporator to the compressor crankcase. Refrigerant migration normally occurs when the compressor is installed in a cold area. A crankcase heater and/or a pumpdown cycle provide good protection against refrigerant migration.</li> <li>▪ Acid formation: Acid forms in the presence of moisture, oxygen, metal, salts, metal oxides and/or high discharge temperatures. The chemical reactions are accelerated at higher temperatures. Oil and acid react with each other. Acid formation leads to damage of the moving parts and in extreme cases to motor burnout. Several different test methods can be used to test for acid formation. If acid is present a complete oil change (including the oil in the oil separator) will help. A suction filter which removes acid should also be fitted. Check filter-drier condition.</li> </ul>

Condition	Cause	Corrective action
The Scroll compressor does not run, no buzz sound can be heard	Defective system control components	Check if the pressure control or thermostat works properly or if the controls are open.
	Power circuit open	Check the fuse for a tripped circuit breaker or for an open disconnected switch.
	Burned motor winding	<ul style="list-style-type: none"> <li>▪ If motor burned due to undersized contactors, you will observe that the contacts welded together. Complete motor burnout on all three phases despite the presence of a functioning protection system can be the result. For sizing information please consult with Contactor manufacturer data sheet. If the application of the compressor is changed the contactor sizing should be rechecked.</li> </ul> Check for unbalanced voltage.
	High discharge pressure / suction pressure	<ul style="list-style-type: none"> <li>▪ For high discharge pressure:               <ul style="list-style-type: none"> <li>- Check for system leaks.</li> <li>- Check the system design. Make sure the discharge line is correctly sized: undersized discharge line can increase discharge pressure. This is also true for an undersized condenser. Correct the component selection as needed.</li> <li>- Check the fan motor, make sure it is running properly in the right direction. Check the condenser: if dirt has been accumulated it will clog the airflow; clean as necessary. High discharge pressure is also caused by an overcharged system and high ambient temperature surrounding the condenser.</li> </ul> </li> <li>▪ For high suction pressure, check the “evaporator superheat” first to diagnose the problem:               <ul style="list-style-type: none"> <li>- High superheat at the evaporator outlet: this is likely in case of excessive pressure-drop in the liquid line or too much vertical lift on the pipe work.</li> </ul> </li> <li>▪ Low superheat at the evaporator outlet is characterized by oversized selection of the expansion valve or incorrect bulb sensor mounting. The valve may freeze up in the open position due to accumulation of debris in the system. For a system with very short refrigeration lines an accumulator is recommended.</li> </ul>
The Scroll compressor trips on motor protection	Compressor operating outside the design limits	<ul style="list-style-type: none"> <li>- Check the compressor suction and discharge pressures while it is running. Make sure they are within the operating envelope.</li> </ul>

Condition	Cause	Corrective action
	Defective motor protector	If all operating conditions are normal, the voltage supply at the compressor terminals is balanced and within limits, the compressor crankcase temperature is within normal limits, and the amperage drawn is within the specified range, the motor protector may be defective.
Excessive discharge temperature	Insufficient cooling medium injected	For compressors using vapour injection, make sure the expansion valve is connected at a distance between 150 mm and 200 mm from the economizer inlet and at a position not lower than inlet connection. The injection line economizer to compressor should be properly sized to avoid pressure drop. For good refrigerant distribution in the economizer respect the recommendations especially those regarding the inlet pipes for the vapour injection according to BHE-manufacturer. The liquid line from the BHE to the expansion valve(s) need to be well insulated as well. A solenoid valve should be installed on the liquid line to prevent refrigerant migration.
	Too high compressor superheat	Make sure the compressor operates within the acceptable superheat range published by Emerson.
The Scroll compressor runs continuously	Excessive cooling/heating load or inadequate insulation	Check the load design; make sure that proper insulation is applied. Correct it as necessary.
	Control circuit inoperative	Check the thermostat, measure the temperature of the room and compare with the thermostat; replace or recalibrate the thermostat. Check the LP control switch and replace it if it is found defective.
Compressor lubrication problem	Oil trap due to incorrect piping layout / sizing	Check the piping layout design. Installations of pipe being routed over or around obstacles can inadvertently create unwanted traps for the oil return. As much as possible the refrigerant line should travel a direct and straight course between the evaporator and compressor. It should also be remembered that the entire system will be coated in oil to some extent. Oil viscosity changes with temperature. More oil stays in the system than was originally expected. Make sure the line is correctly sized.
	Oil pump out due to high cycling rate	A high cycling rate will pump oil into the system and lead to lubrication failure. Oil leaves the compressor at start-up and the short running time is insufficient to return the oil to the compressor via the suction side. Try to limit the number of cycles to maximum 10 per hour.
	Low gas velocity	System gas velocity changes depending on temperature and load (capacity control). In low load conditions gas velocity may not be high enough to return oil to the compressor.
Low discharge pressure	Low ambient temperature	Fit a fan cycling control system.
	Refrigerant undercharge	Check the system for leaks. Observe sight glass for bubbles. Add refrigerant until the sight glass is clear.



Condition	Cause	Corrective action
Low suction pressure	System design load too small	If the compressor is running in a tandem or in parallel, modulate the running process.
	Inadequate refrigerant going to the evaporator	Lower normal discharge pressure values can lead to insufficient refrigerant flow to the system. This can also be verified by checking the evaporator outlet superheat, if it is found unusually high. Check the selection of the expansion valve (likely undersized).
Noise during shut-off	Anti-reverse device	This does not have any effect on the durability of the compressor, no action is necessary.

When troubleshooting a compressor in combination with the drive please follow the recommendations below:

- Before servicing shut off and secure the power supply. Wait for 2 minutes before performing any servicing on the drive.
- Drive: Check all the external wiring for miss-wiring, broken leads or a cable short circuit. Check for loose or burned contacts. Check for burned components on the board.
- Chokes/PFC: Check all the wiring and check for loose or burned contacts.
- External sensors: Make sure that the external sensors are properly connected and still working (discharge temperature sensor and high pressure switch).
- Drive cooling: For air-cooled drives, make sure that the airflow is not obstructed.
- EMI filter: Check all the wiring and check for loose or burned contacts on the board.
- Compressor: Make sure the compressor is running within the envelope. Check the winding resistances from the compressor motor and the cables between compressor and drive. Check for loose or burned contacts.

## 8 Dismantling & disposal



### Removing oil and refrigerant:

- Do not disperse in the environment.
- Use the correct equipment and method of removal.
- Dispose of oil and refrigerant in accordance with national legislation and regulations.
- Dispose of compressor and drive in accordance with national legislation and regulations.

## 9 Reference list of related technical information

Please visit [www.climate.emerson.com/en-gb](http://www.climate.emerson.com/en-gb) for free download of the latest update of these application guidelines and for the documents listed below.

### Additional technical information:

- C.7.9.1 "Motors for Copeland Scroll™ Compressors"
- C7.11.2 "Mounting parts for Copeland Scroll™ compressors"
- C7.11.4 "Sound shell installation instructions for Copeland Scroll™ compressors"
- C7.4.3 "Vapour injection Scroll compressors for heat pumps"
- C7.8.6 "Discharge gas temperature protection with ZH compressors"

### 2D-Drawings and certificates:

The latest updates of the drawings and certificates are available from our home page.

### Performance and technical data:

The latest version of Copeland brand products Select software with performance data and technical data is available from our home page.

### Spare parts and accessories:

The latest version of Emerson spare parts tool with spare parts and accessories is available from our home page.

## DISCLAIMER

---

1. The contents of this publication are presented for informational purposes only and are not to be construed as warranties or guarantees, express or implied, regarding the products or services described herein or their use or applicability.
2. Emerson Climate Technologies GmbH and/or its affiliates (collectively "Emerson"), as applicable, reserve the right to modify the design or specifications of such products at any time without notice.
3. Emerson does not assume responsibility for the selection, use or maintenance of any product. Responsibility for proper selection, use and maintenance of any Emerson product remains solely with the purchaser or end user.
4. Emerson does not assume responsibility for possible typographic errors contained in this publication.

Safety  
instructions

Product  
description

Installation

Electrical  
connection

Starting up &  
operation

Maintenance &  
repair

Trouble-  
shooting

Dismantling &  
disposal

References

#### BENELUX

Josephinastraat 19  
NL-6462 EL Kerkrade  
Tel: +31 45 535 06 73  
Fax: +31 45 535 06 71  
benelux.sales@emerson.com

#### GERMANY, AUSTRIA & SWITZERLAND

Senefelder Str. 3  
DE-63477 Maintal  
Tel: +49 6109 605 90  
Fax: +49 6109 60 59 40

#### FRANCE, GREECE & MAGHREB

8, Allée du Moulin Berger  
FR-69134 Ecully Cédex, Technoparc - CS 90220  
Tel: +33 4 78 66 85 70  
Fax: +33 4 78 66 85 71

#### ITALY

Via Ramazzotti, 26  
IT-21047 Saronno (VA)  
Tel: +39 02 96 17 81  
Fax: +39 02 96 17 88 88  
italy.sales@emerson.com

#### SPAIN & PORTUGAL

C/ Pujades, 51-55 Box 53  
ES-08005 Barcelona  
Tel: +34 93 412 37 52  
iberica.sales@emerson.com

#### CZECH REPUBLIC

Hajkova 22  
CZ - 133 00 Prague  
Tel: +420 733 161 651  
Fax: +420 271 035 655  
Pavel.Sudek@emerson.com

#### ROMANIA & BULGARIA

Parcul Industrial Tetarom 2  
Emerson Nr. 4 400641 Cluj-Napoca  
Tel: +40 374 13 23 50  
Fax: +40 374 13 28 11  
ro-bg.sales@emerson.com

#### ASIA PACIFIC

Suite 2503-8, 25/F, Exchange Tower  
33 Wang Chiu Road, Kowloon Bay  
Kowloon, Hong Kong  
Tel: +852 2866 3108  
Fax: +852 2520 6227

#### UK & IRELAND

Unit 17, Theale Lakes Business Park  
Reading, Berkshire RG7 4GB  
Tel: +44 1189 83 80 00  
Fax: +44 1189 83 80 01  
uk.sales@emerson.com

#### SWEDEN, DENMARK, NORWAY & FINLAND

Pascalstr. 65  
DE-52076 Aachen  
Tel: +49 2408 929 0  
Fax: +49 2408 929 525  
nordic.sales@emerson.com

#### EASTERN EUROPE & TURKEY

Pascalstr. 65  
DE-52076 Aachen  
Tel: +49 2408 929 0  
Fax: +49 2408 929 525  
easterneurope.sales@emerson.com

#### POLAND

Szturmowa 2  
PL-02678 Warsaw  
Tel: +48 22 458 92 05  
Fax: +48 22 458 92 55  
poland.sales@emerson.com

#### RUSSIA & CIS

Dubininskaya 53, bld. 5  
RU-115054, Moscow  
Tel: +7 - 495 - 995 95 59  
Fax: +7 - 495 - 424 88 50  
ECT.Holod@emerson.com

#### BALKAN

Selska cesta 93  
HR-10 000 Zagreb  
Tel: +385 1 560 38 75  
Fax: +385 1 560 38 79

#### MIDDLE EAST & AFRICA

PO Box 26382  
Jebel Ali Free Zone - South, Dubai - UAE  
Tel: +971 4 811 81 00  
Fax: +971 4 886 54 65  
mea.sales@emerson.com

For more details, see [www.climate.emerson.com/en-gb](http://www.climate.emerson.com/en-gb)  
Connect with us: [facebook.com/EmersonCommercialResidentialSolutions](https://facebook.com/EmersonCommercialResidentialSolutions)



Emerson Commercial & Residential Solutions  
Emerson Climate Technologies GmbH - Pascalstrasse 65 - 52076 Aachen, Germany  
Tel. +49 (0) 2408 929 0 - Fax: +49 (0) 2408 929 570 - Internet: [www.climate.emerson.com/en-gb](http://www.climate.emerson.com/en-gb)

The Emerson logo is a trademark and service mark of Emerson Electric Co. Emerson Climate Technologies Inc. is a subsidiary of Emerson Electric Co.  
Copeland is a registered trademark and Copeland Scroll is a trademark of Emerson Climate Technologies Inc. All other trademarks are property of their respective owners.  
Emerson Climate Technologies GmbH shall not be liable for errors in the stated capacities, dimensions, etc., as well as typographic errors. Products, specifications, designs and technical data contained in this document are subject to modification by us without prior notice. Illustrations are not binding.

© 2019 Emerson Climate Technologies, Inc.

**EMERSON. CONSIDER IT SOLVED.™**