

New RoHS Compliant MultiFlex Board

New RoHS MultiFlex and Legacy Board Comparison

- Board width and mounting dimensions have not changed.
- RoHS compliant.
- I/O board versions do not include a battery. Unit controller boards such as RTU/RCB types do include a battery.

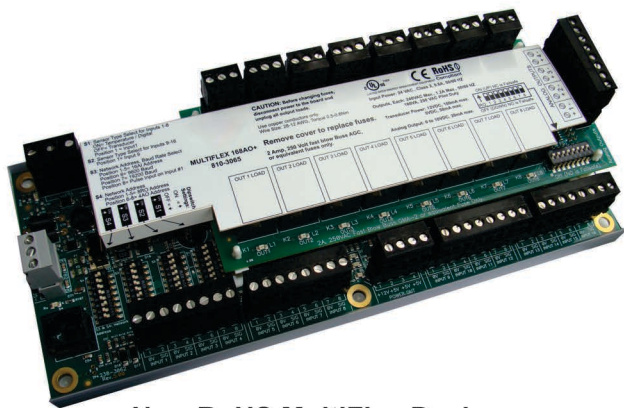

New RoHS MultiFlex Design



Legacy MultiFlex Design

About RoHS

Restriction of Hazardous Substances.

RoHS compliance means that the materials used in this product meet the restricted use of materials that are hazardous and pollute landfills.

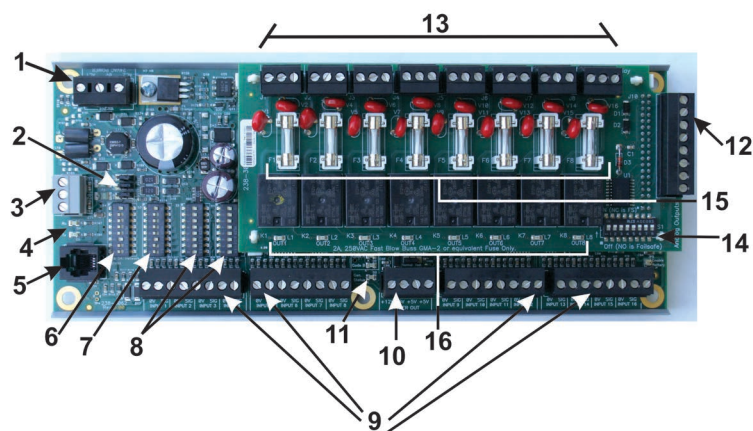

LEGEND	
1	AC Input Power Connection
2	Termination Resistance Jumpers (three)
3	I/O Network Connection
4	I/O Net Tx and Rx LEDs
5	Hand-Held Terminal Port
6	The 8RO and 4AO Address Dip Switch (S4)
7	The 16AI address and network baud rate dip switch (S3)
8	Input Dip Switches (S1 and S2)
9	Input Connections (16)
10	Transducer Power Out
11	General Status LED
12	Analog Outputs (4)
13	Form C Relay Outputs (8)
14	Network Failsafe
15	Relay Output Fuses (8)
16	Output LEDs (OUT1-OUT8)

New RoHS MultiFlex Board Layout

MultiFlex Board Options and Part Numbers

Part Number	MultiFlex Board Type	Part Number	MultiFlex Board Type
810-3013	MultiFlex 16	810-3074	MultiFlex RCB-P
810-3062	MultiFlex RTU	810-3075	MultiFlex RCB
810-3063	MultiFlex 88AO	810-3077	MultiFlex 1616LDO
810-3064	MultiFlex 88	810-3080	MultiFlex CUB
810-3065	MultiFlex 168AO	810-3081	MultiFlex CUB TD
810-3066	MultiFlex 168-16 Input; 8 Relay Out MultiFlex 168-16 In, 8 Out	810-3082	MultiFlex PAK
810-3067	MultiFlex 168DO	810-3083	MultiFlex PAK
810-3072	MultiFlex 1616L	810-3085	MultiFlex CUB - 1 Suction Pressure
810-3073	MultiFlex 1616LAO	810-3086	MultiFlex CUB

Visit our website at copeland.com/en-us/products/controls-monitoring-systems for the latest technical documentation and updates. For Technical Support call **833-409-7505** or email ColdChain.TechnicalServices@Copeland.com

026-4249 R2

The contents of this publication are presented for informational purposes only and they are not to be construed as warranties or guarantees, express or implied, regarding the products or services described herein or their use or applicability. Copeland reserves the right to modify the designs or specifications of such products at any time without notice. Responsibility for proper selection, use and maintenance of any product remains solely with the purchaser and end-user. ©2024 Copeland is a trademark of Copeland LP.

COPELAND