

Copeland™ Commercial HVACR Variable Frequency Drive – EVH Series QUICK START GUIDE



This guide is a supplement to the application manual supplied with the drive. Improper wiring can cause bodily harm and damage the equipment. Follow good wiring practices and all applicable codes and standards.

MODEL NAMEPLATE

- Verify you received the correct model drive.
- Compare the drive nameplate VOLTS and AMPS rating with the motor or compressor nameplate.
- Check that the power source meets the input power requirements.
- Output power from the drive should match the motor requirement.

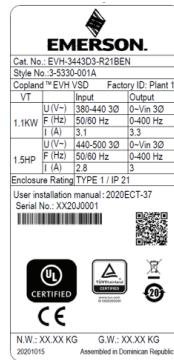

KEYPAD AND DISPLAY

- Use ▲ and ▼ arrows to navigate a menu list and change parameter values.
- Use ► arrow to enter parameter group mode and ◀ arrow to back up one step.

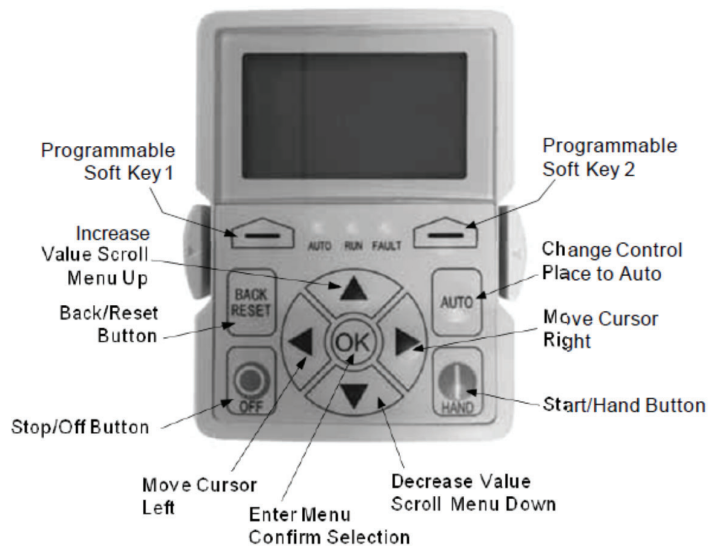

AC POWER WIRING

- Locate the power terminal strip.
- Check the AC voltage rating shown on the drive nameplate with the AC incoming voltage.
- Turn the power off and make connections.

I/O WIRING

Refer to the *EVH Install Manual* for the complete I/O wiring guide.

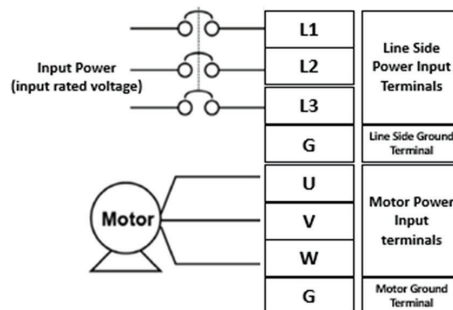

START UP WIZARD PARAMETERS

The following table lists the standard parameters in the Startup Wizard that happen when the drive is energized. Refer to the application manual for parameter descriptions.

Item	Par. Name	Description
1	Startup Wizard Enable	Press ok
2	Application	0=Basic; 1=PID; 2=Advanced
3	Language	0 = English; 2 = Deutsch
4	Real Time Clock	yy.mm.dd hh:mm:ss
5	Daylight Saving	0 = Off; 1 = EU; 2 = US
6	Min Frequency	Min: 0.00 Hz Max: Max Freq
7	Max Frequency	Min: Min Frequency Max: 400.00 Hz
8	Motor Nom Current	Min: 0.1A Max: 500 A
9	Current Limit	Min: lh*1/10 Max: lh*2
10	Motor Nom Speed	Min: lh*1/10 Max: lh*2
11	Motor PF	Min: 0.30 Max: 1.0
12	Motor Nom Voltage	Min: 180V Max: 690V
13	Motor Nom Frequency	Min: 30.00 Hz Max: 400.00 Hz
14	Accel Time	Min: 0.1 sec Max: 3000 sec
15	Decel Time	Min: 0.1 sec Max: 3000.0 sec
16	Hand Control Place	0 = Keypad; 1 = I/O Terminal Start 1; 2 = I/O Terminal Start 2; 3 = Fieldbus
17	Hand Reference	0 = AI1; 1 = AI2; 2 = Slot A: AI1; 3 = Slot B: AI1; 4 = AI1 Joystick; 5 = AI2 Joystick; 6 = Keypad; 7 = Fieldbus; 9 = Max Frequency; 10 = AI1 + AI2; 11 = AI1 -AI2; 12 = AI2 -AI1; 13 = AI1 * AI2; 14 = AI1 or AI2; 15 = Min(AI1,AI2); 16 = Max(AI1,AI2); 17 = PID1 Control Output; 18 = PID2 Control Output
18	Auto 1 Control Place	0 = I/O Terminal Start 1; 1 = Fieldbus; 2 = I/O Terminal Start 2; 3 = Keypad
19	Auto 1 Control Reference	0 = AI1; 1 = AI2; 2 = Slot A: AI1; 3 = Slot B: AI1; 4 = AI1 Joystick; 5 = AI2 Joystick; 6 = Keypad; 7 = Fieldbus; 9 = Max Frequency; 10 = AI1 + AI2; 11 = AI1 -AI2; 12 = AI2 -AI1; 13 = AI1 * AI2; 14 = AI1 or AI2; 15 = Min(AI1,AI2); 16 = Max(AI1,AI2); 17 = PID1 Control Output; 18 = PID2 Control Output
20	Bypass Enabled	0 = Disabled; 1 = Enabled

FREQUENTLY ASKED QUESTIONS

Q: How do I reset the drive back to factory default settings?

A: Hold the OFF/STOP and BACK/RESET buttons for 5 seconds to return drive to factory default.

Q: How do I adjust the time it takes the motor to speed up or slow down?

A: To adjust the time for the motor to accelerate to set speed, find parameter P1.3 (accel time). To adjust the time for the motor to decelerate to 0, find parameter P1.4 (decel time).

Q: How do I prevent the drive from tripping on an overvoltage fault while my motor is ramping down?

A: Make the deceleration time longer for your ramp down, check input voltage, or activate overvoltage controller in parameter P5.1.12.

Q: Can I run my motor above the nominal motor speed?

A: The motor should be run within the speed range specified by the manufacturer. For Copeland™ compressors, please see AE-1466 for allowed speed ranges.



Scan for more information or visit
Climate.Emerson.com/CopelandVariableFrequencyDrives