

# Copeland compressors for transcritical CO<sub>2</sub> refrigeration

***Designed for durability and best-in-class performance***

The Copeland line of 4-cylinder CO<sub>2</sub> compressors is the ideal solution for R-744 transcritical booster systems. It is characterized by a design operating pressure of 1740 psig (120 bar). Refrigerant flow and heat transfer have been optimized for superior efficiency. All compressors are equipped with Copeland compressor electronics technology (formerly CoreSense), offering faster system troubleshooting and protection from problems before they occur.

***Designed for flexibility in system design and operation***

- Compact dimensions
- UL Recognized
- Integrated high pressure ASME certified safety valves
- Discharge temperature protection
- Service valve rotates 360° for ease of piping design
- Three sight glasses for mounting of oil management control and visual oil level inspection while running
- One oil port for oil equalization in parallel system
- Oil splasher system ensures lubrication at constant and variable speed on 4MTLS40K to 4MTLS15M models
- Accessories available



## ***Medium Temp Operating Envelope***

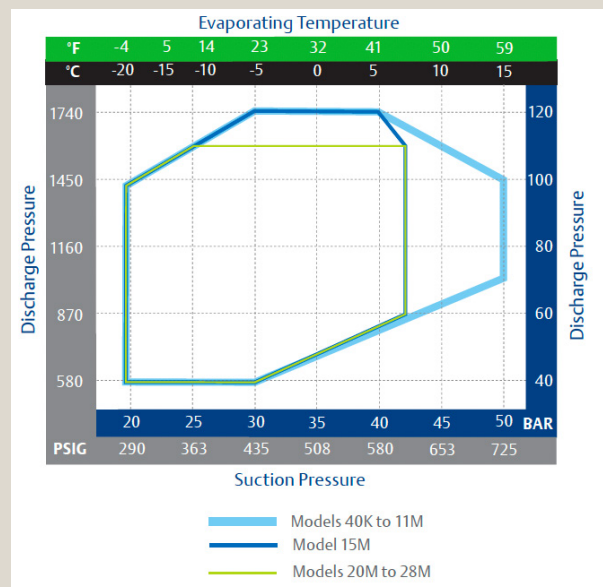

**COPELAND**

***Designed for durability and performance in R-744 applications***

- Low sound and vibration
- Large discharge chamber reduces pulsation
- High design pressures of 1958 psig (135 bar) high side and 1305 psig (90 bar) low side
- Cylinder head and discharge plenum design minimizes heat transfer to suction side
- Stepless capacity modulation when applied with inverter
- Copeland compressor electronics module

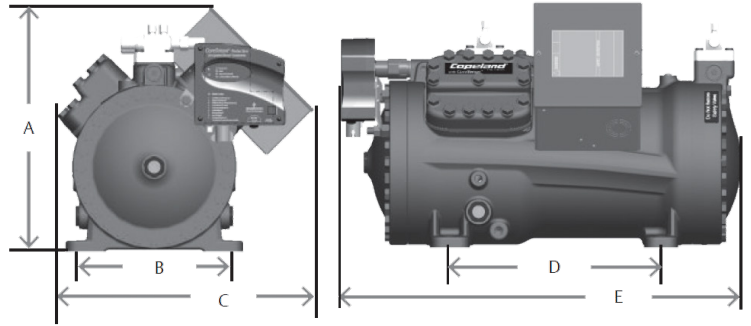

**Dimensions**

Dimension	4MTLS40KE-64KE mm (in)	4MTLS82KE-15ME mm (in)	4MTLS20ME-28ME mm (in)
A	413 (16.3)	433 (17)	466 (18.3)
B	256 (10.1)	256 (10.1)	256 (10.1)
C	428 (16.9)	455 (17.9)	469 (18.5)
D	368 (14.5)	368 (14.5)	368 (14.5)
E	630 (24.8)	697 (27.4)	842 (33.1)

***Technical overview***

**Medium Temp 4MTLS Compressors (20°F Evap/95°F Gas Cooler/18°F Superheat)**

Model	Nominal HP	Displacement CFH	Capacity kBtu/hr	High/Low Side Max Operating Pressure PSIG (BAR)	High/Low Side Design Pressure PSIG (BAR)	High/Low Side Burst Pressure PSIG (BAR)
4MTLS40KE	5	196.9	42.2	1740/725 (120/50)	1958/1305 (135/90)	6092/4786 (420/330)
4MTLS53KE	7	261.8	56.6			
4MTLS64KE	8	317.4	70.1			
4MTLS82KE	11	406.5	91.6			
4MTLS11ME	14	531.2	118.0	1740/609 (120/42)	1958/1305 (135/90)	6092/4786 (420/330)
4MTLS15ME	20	765.0	173.5			
4MTLS20ME	24	966.2	212.4	1595/609 (110/42)	1958/1305 (135/90)	6092/4786 (420/330)
4MTLS22ME	29	1134	252.4			
4MTLS28ME	34*	1363*	307.0*			

To learn more, visit [copeland.com/co2](http://copeland.com/co2)

2012ECT-33 R9 (12/21) ©2024 Copeland LP.

