

VILTech retrofit kit for Vilter™ reciprocating compressors



- Pre-assembled and easy to install
- Simple and reliable design
- Easy to use and navigate
- Full compressor protection
- Remote communications capability
- Multi-compressor sequencing

Vilter™

EMERSON™
Climate Technologies

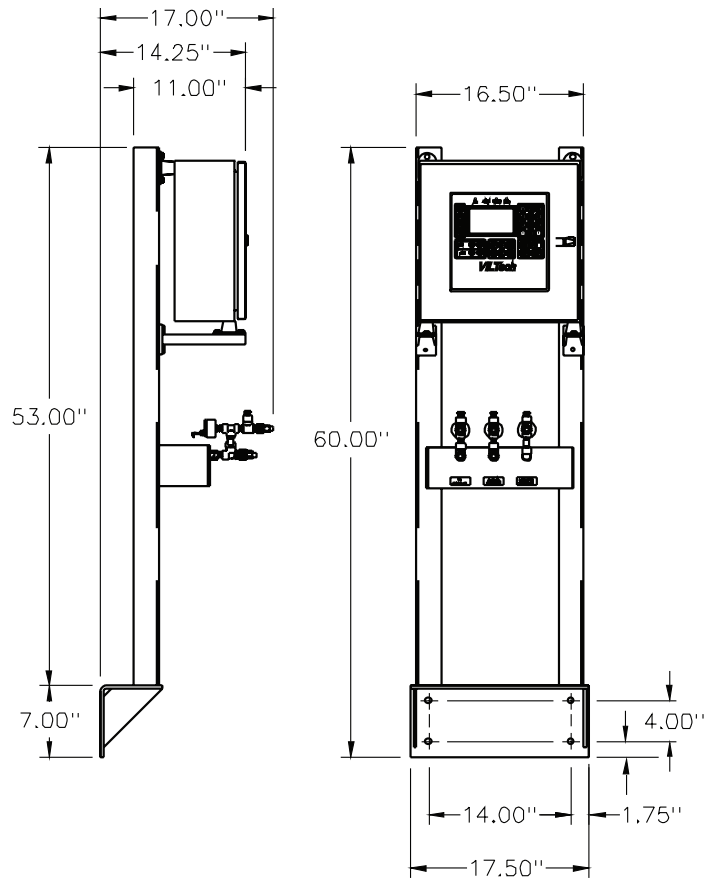

Features	Single stage		Integral two-stage 6 & 12 Cylinder compressor
	2-8 Cylinder compressors	12 & 16 Cylinder compressors	
VILTech Micro-Controller ¹	✓	✓	✓
Support frame ¹	✓	✓	✓
Vibration Isolators ¹	✓	✓	✓
Block and bleed assembly ¹	✓	✓	✓
Pressure transducers and cables ¹	3	4	4
RTD's with wells and cables ²	3	3	3
Mounting hardware ²	✓	✓	✓
VILTech manual ²	✓	✓	✓

¹Factory pre-assembled on support frame

²Shipped loose for field installation

Transducer tubing not included

Options:

VFD Output module - 4-20mA

Process temperature control - Includes RTD with well and cable

EmersonClimate.com

2012VM-60 R1 (1/14) Emerson and Vilter are trademarks of Emerson Electric Co. or one of its affiliated companies. ©2014 Emerson Climate Technologies, Inc. All rights reserved.

EMERSON. CONSIDER IT SOLVED.™