

Blower Package PLC

Operation manual



Blower Packages - Standard Vilter Warranty Statement

Seller warrants all new assembled equipment manufactured by it and supplied to Buyer to be free from defects in materials and workmanship for a period of (a) eighteen (18) months from the date of shipment or (b) twelve (12) months from the date of installation at the end user's location, whichever occurs first.

If within such period any such product shall be proved to Seller's satisfaction to be defective, such product shall be repaired or replaced at Seller's option. Such repair or replacement shall be Seller's sole obligation and Buyer's exclusive remedy hereunder and shall be conditioned upon (a) Seller's receiving written notice of any alleged defect within ten (10) days after its discovery, (b) payment in full of all amounts owed by Buyer to Seller and (c) at Seller's option, Buyer shall have delivered such products to Seller, all expenses prepaid to its factory. Expenses incurred by Buyer in repairing or replacing any defective product (including, without limitation, labor, lost refrigerant or gas and freight costs) will not be allowed except by written permission of Seller. Further, Seller shall not be liable for any other direct, indirect, consequential, incidental, or special damages arising out of a breach of warranty.

This warranty is only applicable to products properly maintained and used according to Seller's instructions. This warranty does not apply (i) to ordinary wear and tear, damage caused by corrosion, misuse, overloading, neglect, improper use or operation (including, without limitation, operation beyond rated capacity), substitution of parts not approved by Seller, accident or alteration, as determined by Seller or (ii) if the product is operated on a gas with an H2S level not approved by Seller. In addition, Seller does not warrant that any equipment and features meet the requirements of any local, state or federal laws or regulations. Products supplied by Seller hereunder which are manufactured by someone else are not warranted by Seller in any way, but Seller agrees to assign to Buyer any warranty rights in such products that Seller may have from the original manufacturer. Labor and expenses for repair are not covered by warranty.

THE WARRANTY CONTAINED HEREIN IS EXCLUSIVE AND IN LIEU OF ALL OTHER REPRESENTATIONS AND WARRANTIES, EXPRESS OR IMPLIED, AND SELLER EXPRESSLY DISCLAIMS AND EXCLUDES ANY IMPLIED WARRANTY OF MERCHANTABILITY OR IMPLIED WARRANTY OF FITNESS FOR A PARTICULAR PURPOSE.

Any description of the products, whether in writing or made orally by Seller or Seller's agents, specifications, samples, models, bulletins, drawings, diagrams, engineering sheets or similar materials used in connection with Buyer's order are for the sole purpose of identifying the products and shall not be construed as an express warranty. Any suggestions by Seller or Seller's agents regarding use, application or suitability of the products shall not be construed as an express warranty unless confirmed to be such in writing by Seller.

Important Message

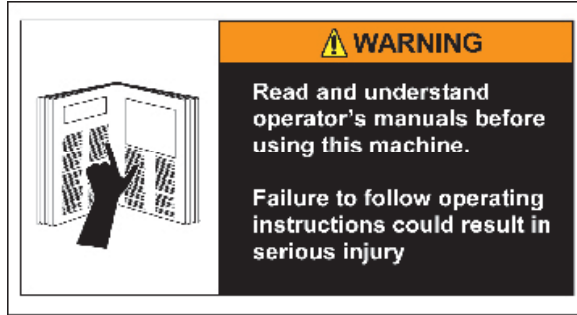

READ CAREFULLY BEFORE INSTALLING AND STARTING YOUR BLOWER.

The following instructions have been prepared to assist in installation, operation and maintenance of Vilter blower packages. Following these instructions will result in a long life of the package with satisfactory operation.

The entire manual should be reviewed before attempting to install, operate, service or repair any part of the package.

A blower is a positive displacement machine. It is designed to compress gas. The blower must not be subjected to liquid carry over. Care must be exercised in properly designing and maintaining the system to prevent conditions that could lead to liquid carry over. Vilter Manufacturing is not responsible for the system or the controls needed to prevent liquid carry over and as such Vilter Manufacturing cannot warrant equipment damaged by improperly protected or operating systems.

Vilter components are thoroughly inspected at the factory. However, damage can occur in shipment. For this reason, the equipment should be thoroughly inspected upon arrival. Any damage noted should be reported immediately to the Transportation Company. This way, an authorized agent can examine the unit, determine the extent of damage and take necessary steps to rectify the claim with no serious or costly delays. At the same time, the local Vilter representative or the home office should be notified of any claim made.

All inquires should include the Vilter sales order number, serial and model number. These can be found on the nameplate on the blower.

All requests for information, services or parts should be directed to:

Vilter Manufacturing LLC
Customer Service Department
P.O. Box 8904
5555 South Packard Ave
Cudahy, WI 53110-8904 USA
Telephone: 1-414-744-0111
Fax: 1-414-744-3483
E-mail: info.vilter@emerson.com

Equipment Identification Numbers:

Vilter Order Number: _____ Blower Serial Number: _____
Vilter Order Number: _____ Blower Serial Number: _____
Vilter Order Number: _____ Blower Serial Number: _____
Vilter Order Number: _____ Blower Serial Number: _____

Table of Contents

Section Title	Section Number
Blower Packages - Standard Vilter Warranty Statement.....	i
Important Message.....	ii
Section 1 • General Information	
How To Use This Manual.....	1-1
Glossary of Terms.....	1-2
Hardware Components.....	1-4
Wiring Requirements.....	1-6
VFD Installation Recommendations	1-7
Section 2 • Operation Descriptions	
Overview	2-1
Operational Descriptions and Diagrams	2-2
Configuration of the Blower Package	2-2
Starting of the Blower/Permissives.....	2-2
Anti-Recycle	2-2
Automatic Speed Control.....	2-2
Operating Modes.....	2-3
Load Limits and Forced Unloading.....	2-3
Safeties.....	2-3
Emergency Stop	2-5
Supplemental Blower Motor Protection	2-5
Air Cooled Oil Cooler Fan.....	2-6
External Electric Oil Pump	2-6
Oil Pressure Safety Switch	2-6
Air Cooled Aftercooler - Step Type.....	2-6
Air Cooled Aftercooler - VFD Type	2-7
Water Cooled Gas Aftercooler	2-8
Gas Scrubbers	2-9
Discharge Recycle Valve.....	2-10
Section 3 • Overview Screens	
Blower and System Overview Screens	3-1
Section 4 • HMI Navigation	
Main Menu Screen	4-1
HMI Security.....	4-2
Default	4-2
OP1, OP2, OP3, OP4, OP5 (Operators)	4-2
Super (Supervisor)	4-2
Logging In.....	4-2
Section 5 • Configuration - Supervisor Level	
Configuration Screen - Supervisor (SUPER) Level	5-1
Editing Device Names	5-4

Table of Contents

Section Title	Section Number
Section 6 • Instrument Calibration	
Calibration Main Screen	6-1
Pressure Calibration Screen.....	6-2
Calibrate Pressure Instrument.....	6-3
Calibrate Transducer to a Known Pressure.....	6-3
Temperature Calibration Screen.....	6-4
Calibrate Temperature Instrument.....	6-4
Other Analog Calibration Screen	6-5
Calibrate an Additional Instrument	6-5
Section 7 • Blower Configuration and Control Setpoints	
Setpoints and Control Screens	7-1
Changing Setpoints	7-1
Blower Configuration Screen.....	7-2
Blower Control Setpoints - Suction Pressure.....	7-3
Blower Control Setpoints - Discharge Pressure	7-5
Section 8 • Alarm and Trip Setpoints	
Alarm and Trip Setpoints.....	8-1
Alarm and Trip Setpoints - Page 1	8-1
Alarm and Trip Setpoints - Page 2.....	8-2
Section 9 • Step and PID Device Control Screens	
Aftercooler Screens.....	9-1
Aftercooler (VFD Type) Setpoints	9-1
Aftercooler (Step Type) Setpoints	9-2
Water Cooled Aftercooler Setpoints.....	9-3
Discharge Recycle Valve Screen.....	9-4
Discharge Recycle Valve Setpoints	9-4
Start Menu Popup Screen.....	9-5
Section 10 • Diagnostic Screens	
IO/Comms Diagnostics Screen	10-1
Event List Screen	10-2
Diagnostics Forced Outputs Screen.....	10-3
Captured Data at Shutdown Screen	10-4
Initial Baseline Running Data Screen.....	10-5

Table of Contents

Section Title	Section Number
Section 11 • Alarms, Trips, Status Information and Troubleshooting	
Alarm and Trips	11-1
Alarm Listing.....	11-2
Trip Listing	11-9
Status Messages and Blower State Indicator	11-18
Troubleshooting	11-22
If the Blower Will Not Start.....	11-22
If Control Power Will Not Turn On	11-22
Section 12 • Central Controller Communications	
Communication with a Central Controller/DCS	12-1
VPN Access	12-1
Setting Up Communications	12-1
Watchdog Timer.....	12-1
Data that can be Read from the Blower PLC	12-1
Live Instrument Data	12-1
Alarm and Trip Data	12-8
Status Data	12-17
States of Discrete I/O	12-21
Blower State Indicator.....	12-25
Data that can be Written to the Blower PLC	12-26
Discrete Blower Commands	12-26

List of Tables and Figures

Table/Figure	Section Number
Tables	
Table 11-1. Alarm Listing.....	11-2
Table 11-2. Trip Listing	11-9
Table 11-3. Status Listing	11-16
Table 12-1. Engineered Units Value Interpretation (INT_OUT[x])	12-2
Table 12-2. Live Instrument Data.....	12-2
Table 12-3. Alarm Data.....	12-8
Table 12-4. Trip Data	12-12
Table 12-5. Status Data	12-17
Table 12-6. Discrete Input States.....	12-21
Table 12-7. Discrete Output States.....	12-23
Table 12-8. State Indicator	12-25
Table 12-9. Blower Command (Real).....	12-26
Table 12-10. Blower Command (Double Integer).....	12-26
Figures	
Figure 2-1. Operational Diagram - Load Limits / Forced Unloading (Example)	2-4
Figure 2-2. Control Panel Master Power and Emergency Stop Electrical Circuit	2-5
Figure 2-3. Operational Diagram - Air Cooled Aftercooler (Step Type).....	2-6
Figure 2-4. Operational Diagram - Air Cooled Aftercooler (VFD Type)	2-7
Figure 2-5. Operational Diagram - Water Cooled Gas Aftercooler	2-8
Figure 2-6. Operational Diagram - Discharge Recycle Valve	2-10
Figure 3-1. Basic Blower Package Screen	3-1
Figure 4-1. Main Menu Screen	4-1
Figure 4-3. Login Popup Screen	4-2
Figure 4-4. Login Screen Keyboard	4-3
Figure 5-1. Configuration Screen - All Options Shown (Supervisor Level)	5-1
Figure 5-2. Set Date/Time Pop-Up Screen - Supervisor Level.....	5-2
Figure 5-3. Change Password Pop-Up Screen - Supervisor Level.....	5-3
Figure 5-4. Define Device Names - Devices and Vessels (Supervisor Level)	5-4
Figure 5-5. Define Device Names - Instrumentation (Supervisor Level)	5-5
Figure 5-6. Define Device Names - Alarm and Trip 1 (Supervisor Level) (1 of 2)	5-6
Figure 5-7. Define Device Names - Alarm and Trip 2 (Supervisor Level) (2 of 2)	5-7
Figure 6-1. Instrument Calibration Overview Screen	6-1
Figure 6-2. Pressure Calibration Screen - 1 of 3	6-2
Figure 6-3. Pressure Calibration Screen - 3 of 3	6-3
Figure 6-4. Temperature Calibration Screen	6-4
Figure 6-5. Other Analog Calibration Screen	6-5
Figure 7-1. Numeric Entry Pop-up Screen	7-1
Figure 7-2. Blower Configuration Screen	7-2
Figure 7-3. Blower Control Screen - Suction Pressure.....	7-4
Figure 7-4. Blower Control Screen - Discharge Pressure	7-5

List of Tables and Figures

Table/Figure	Section Number
Figure 8-1. Alarm and Trip Setpoints Screen - 1 of 2	8-1
Figure 8-2. Alarm and Trip Setpoints Screen - 2 of 2	8-2
Figure 9-1. Aftercooler (VFD Type) Screen	9-1
Figure 9-2. Aftercooler (Step Type) Screen	9-2
Figure 9-3. Water Cooled Aftercooler Screen.....	9-3
Figure 9-4. Discharge Recycle Valve Screen	9-4
Figure 9-5. Start Menu	9-5
Figure 10-1. IO/Comms Diagnostics Screen.....	10-1
Figure 10-2. Event List Screen.....	10-2
Figure 10-3. Diagnostics Forced Output Screen.....	10-3
Figure 10-4. Captured Data at Shutdown Screen	10-4
Figure 10-5. Initial Baseline Running Data Screen	10-5
Figure 11-1. Alarm/Trip/Status Bars (Main Menu Screen).....	11-1
Figure 11-2. Alarm Popup Screen	11-1
Figure 11-3. Alarm/Trip/Status Bars (Main Menu Screen).....	11-18

Section 1 • General Information

HOW TO USE THIS MANUAL

This manual contains instructions for the PLC. It has been divided into 12 sections:

Section 1: General Information

Section 2: Sequence of Operation

Section 3: Overview Screens

Section 4: HMI Navigation

Section 5: Configuration - Supervisor Level

Section 6: Instrument Calibration

Section 7: Blower Configuration and Control Setpoints

Section 8: Alarms and Trips Setpoints

Section 9: Step and PID Device Control Screens

Section 10: Diagnostics Screens

Section 11: Alarms, Trips, Status Information and
Troubleshooting

Section 12: Communications with a Central
Controller/DCS

It is highly recommended that the manual be reviewed prior to servicing system parts.

Figures and tables are included to illustrate key concepts.

Safety precautions are shown throughout the manual. They are defined as the following:

NOTICE - Notice statements are shown when there are important information that shall be followed. Not following such notices may result in void of warranty, serious fines, serious injury and/or death.

WARNING - Warning statements are shown when there are hazardous situations, if not avoided, will result in serious injury and/or death.

CAUTION - Caution statements are shown when there are potentially hazardous situations, if not avoided, will result in damage to equipment.

NOTE - Notes are shown when there are additional information pertaining to the instructions explained.

ADDITIONAL IMPORTANT NOTES

- Due to continuing changes and unit updates, always refer to the Vilter.com website to make sure you have the latest manual.
- Any suggestions of manual improvements can be made to Vilter Manufacturing at the contact information on page ii.

Section 1 • General Information

Glossary of Terms

Aftercooler Heat Exchanger

Used to cool discharge gas from the blower package.

Aftercooler Outlet Temperature

Temperature of gas measured at the outlet of the Aftercooler.

Alarm Warning

Announced by the blower PLC that an operational or process condition is abnormal. When active, alarms will be displayed but will not shut down the blower package.

Bearing Temperature

Temperature of the bearings of the blower main motor measured by an RTD.

Blower

Positive displacement rotary compressor intended to move high volume of gas at relatively low pressure.

Blower Offset Dwell Time

Amount of time between starting individual blowers. Used in applications where all blowers on a package starting at the same time would put too great of a burden on the electrical infrastructure.

Blower Package

Arrangement of up to 4 blowers controlled by a common PLC controller.

Blower-Specific Trip

A shutdown condition that applies to a specific blower.

Differential Pressure

The difference between two pressures.

Discharge Recycle Control Pressure

Pressure of discharge gas measured at the Discharge Recycle Valve. Used to control the Discharge Recycle Valve.

Discharge Recycle Control Pressure

Pressure of discharge gas measured at the Discharge Recycle Valve. Used to control the Discharge Recycle Valve.

Discharge Recycle Valve

Motorized or Air Actuated Valve that recycles discharge gas back to the suction side of the blower package.

Discharge Pressure

Pressure of the refrigerant or gas measured at the outlet of the blower.

Discharge Temperature

Temperature of the refrigerant or gas measured at the outlet of the blower.

Ethernet IP

Communication protocol used to communicate to the blower PLC.

General Trip

Shutdown condition that applies to the entire blower package. If active, will shut down the entire package.

HMI

HMI stands for “Human-Machine Interface.” The blower HMI is a touchscreen terminal mounted in the door of the blower control enclosure.

Inlet Scrubber

Vessel located on the inlet side of gas blower or gas chiller to remove moisture and/or contaminants.

Inlet Scrubber Inlet Pressure

Pressure of gas measured at the inlet of the inlet scrubber.

Inlet Scrubber Outlet Pressure

Pressure of gas measured at the outlet of the inlet scrubber.

Inlet Scrubber Pressure Drop

Pressure differential between inlet and outlet of the inlet scrubber. Calculated: Scrubber Inlet Pressure minus Scrubber Outlet Pressure.

Main Motor

AC induction motor that is coupled to and drives the blower.

Section 1 • General Information

Oil Cooler

Heat Exchanger where hot oil from the blower is cooled.

Oil Pressure Safety Switch

Pressure switch that shuts down blower on low oil pressure, if installed.

Outlet Scrubber

Vessel located on the outlet side of gas blower or gas chiller to remove moisture, oil, and/or contaminants.

Outlet Scrubber Inlet Pressure

Pressure of gas measured at the inlet of the outlet scrubber.

Outlet Scrubber Outlet Pressure

Pressure of gas measured at the outlet of the outlet scrubber.

Outlet Scrubber Pressure Drop

Pressure differential between inlet and outlet of the outlet scrubber. Calculated: Scrubber Inlet Pressure minus Scrubber Outlet Pressure.

PID Controller

PID stands for “Proportional Integral Derivative.” A PID controller manipulates a control variable (example: valve position or fan/pump speed) to maintain a process variable (example: process temperature or pressure) at a desired value (setpoint). The controller is driven by mathematical calculations that tell the control variable how to react to changes in the process variable.

PLC

PLC stands for “Programmable Logic Controller.” The Blower PLC is an industrial computer that controls and monitors the blower package.

Pressure Transducer or Transmitter

Device that measures pressure and transmits the pressure reading as a 4-20mA signal. This 4-20mA signal is read by the PLC and displayed as a pressure.

RTD

RTD stands for “Resistance Temperature Detector.” RTDs use electrical resistance to measure temperature. This resistance is read by the PLC and displayed as a temperature.

Silencer

Vessel located on the outlet of the blower.

Suction Pressure

Pressure of the refrigerant or gas measured at the inlet of the blower.

Suction Temperature

Temperature of the refrigerant or gas measured at the inlet of the blower.

Temperature Transmitter

Device that measures temperature and transmits the temperature reading as a 4-20mA signal. This 4-20mA signal is read by the PLC and displayed as a temperature.

Trip

Blower shutdown due to an abnormal process or operational condition.

VFD

VFD stands for “Variable Frequency Drive.” A VFD is a motor control device that can vary the speed of an AC induction motor.

VPN

VPN stands for “Virtual Private Network.” A VPN connection allows remote access to the blower PLC.

Winding Temperature

Internal winding temperature of the blower main motor measured by an RTD.

Section 1 • General Information

Hardware Components - PLC Exterior

Each Blower Package PLC may differ, but below are typical components that can be found in each PLC. For specific PLC layout, refer to supplied electrical drawings.

- | | |
|--------------------|---|
| 1 - HMI Cover | 5 - HMI (Panel View Plus 6) |
| 2 - Enclosure Door | 6 - Panel Heater & Mounting (Field Installed) |
| 3 - Door Latch | 7 - Emergency Stop Button |
| 4 - Main Enclosure | 8 - Blower Control Reset Button |
| | 9 - Master Power |

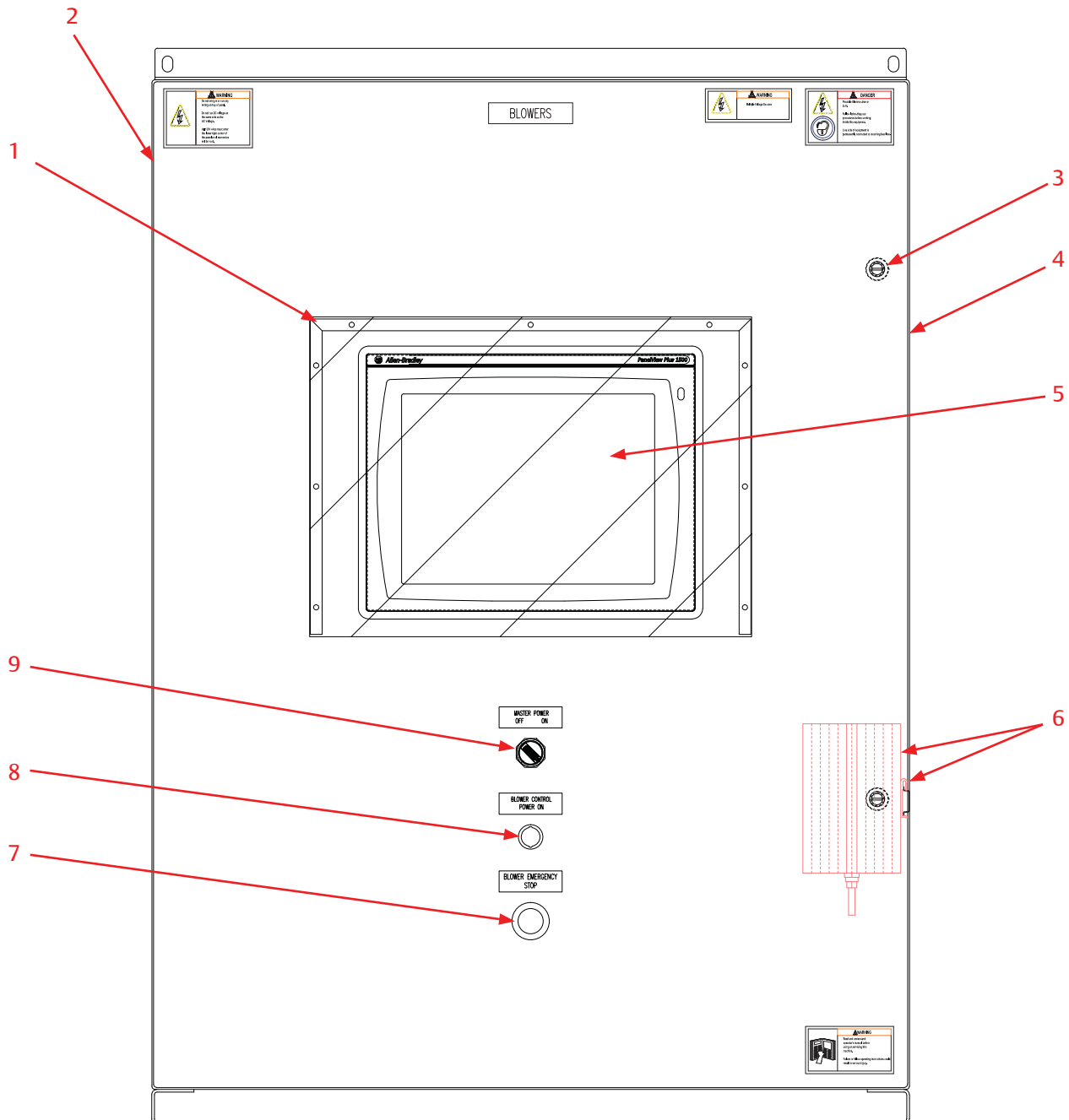

Hardware Components - Main Enclosure Interior

- | | |
|--|---|
| 10 - Terminal Blocks (AC Connections) | 16 - Modules |
| 11 - Relays | 17 - Compact Logix Power Supply |
| 12 - Fuses | 19 - Terminal Blocks (DC Low Voltage Connections) |
| 13 - DC Power Supplies | 20 - Terminal Blocks (Main Power Connections) |
| 14 - UPS | 21 - Terminal Blocks (Customer Connections) |
| 15 - CompactLogix Processor with Ethernet, and Memory Card | 22 - Ethernet Switch, 5 Port RJ45 |

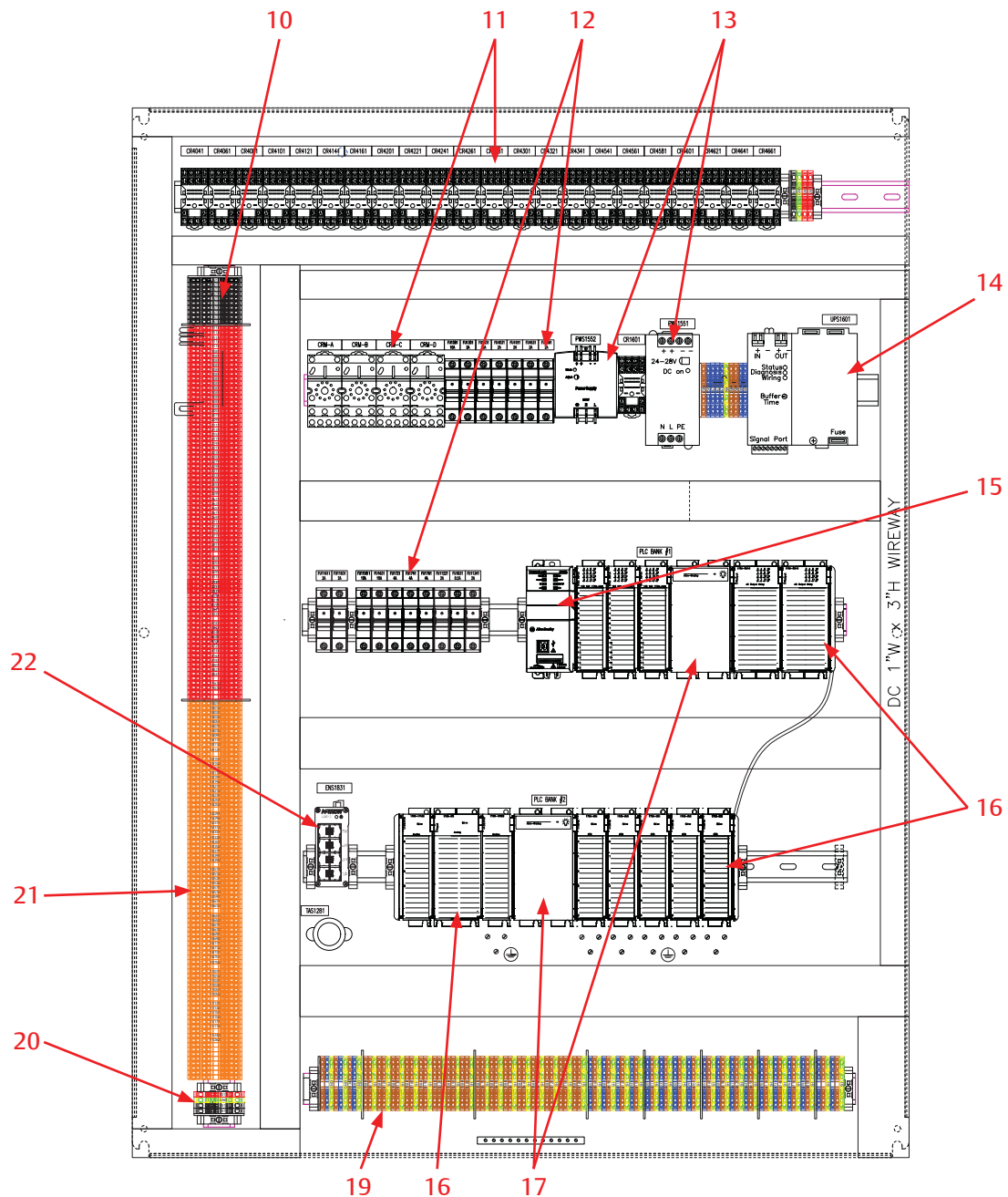

Wiring Requirements

- Incoming power enters on the left bottom wall of the PLC control enclosure. Route these conductors in the space between the sub-panel and inside wall of the enclosure.
- DC control, analog and communications or network wiring enters on the right bottom wall of the PLC control enclosure.
- Wiring external to the panel per NEC (NFPA 70), ANSI 12.12.01 and UL-598A.
- Panel construction and wiring per UL-508A for all panels and ANSI 12.12.01 and UL-698A for hazardous locations.
- Electrical transmission, control, and alarm wiring shall be stranded copper no smaller than #14 AWG. Use JIC color code, unless otherwise noted.
- All control circuits from a source outside of this panel are to be #14 AWG Orange.
- All control circuit neutrals from a source outside of this panel are to be no smaller than #14 AWG White/Orange Tracer.
- All analog inputs are to be connected with shielded cable. Shield terminated at panel side and isolated at device side.
- All shielding is to be grounded at a single point on the chassis.
- Analog wiring must be run separate from AC wiring and kept separate within the enclosure.
- All analog signal wiring shall be grounded at one end only. Ground shield of signal cables.
- Use alpha P/N 2423C, 3 Cond, 18 AWG, shielded or approved equal.
- Only one customer network cable to switch.
- Unused defined as having a previous assignment. Spare defined as no previous assignment.
- Where applicable, remove jumper between connections if used.
- All power circuits from a source outside of this panel are to be no smaller than #12 AWG Orange.
- All power circuit neutrals from a source outside of this panel are to be no smaller than #12 AWG White/Orange Tracer.
- All equipment grounds must be Green/Yellow. For ground conductors larger than #6 AWG, apply Green/Yellow heat shrink or color conductor with marker at both ends.
- All power sources for heating devices shall be supplied by others.
- Designated for a trip function (i.e. limit trip, sequence shutdown, etc.). Recommended hard wire connection.
- Use alpha P/N 2422C, 2 Cond, 18 AWG, shielded or approved equal.
- Category 6 Ethernet cable is recommended for all of our equipment.

SEPARATION OF INTRINSICALLY SAFE CIRCUITS (IF USED)

The intrinsically safe wiring enters on the bottom-left wall of the PLC control enclosure.

To reduce the possibility of interconnection, additional requirements exist for the separation of intrinsically safe and non-intrinsically safe circuits. Exceptions to this rule may be found in NEC Section 504-30(A)(1) and (2).

Separation by distance:

- The distance between intrinsically safe field wiring terminals and non-intrinsically safe field wiring terminals shall be a minimum 8 inches.
- The distance between intrinsically safe field wiring terminals and non-intrinsically safe field circuits shall be a minimum 5 inches.
- The distance between intrinsically safe field wiring terminals and non-intrinsically safe field circuits and wiring shall be a minimum 5 inches.
- The distance between intrinsically safe field wiring terminals and non-intrinsically safe internal wiring shall be a minimum 2 inches.

VFD Installation Recommendations

- All wiring to and from the Variable Frequency Drive (VFD) starter shall conform to the National Fire Protection Association 70 (NFPA-70), local codes and the manufacturer's guidelines and specifications.
- Thoroughly read the manufacturer's VFD installation and instruction manuals.
- In the event of a code and manufacturer recommendation conflict, always use the more stringent standard.
- Only use an inverter duty rated motor built to NEMA MG1 PART 30 & 31.
- Always use copper conductors to feed the VFD starter and motor. Use cable with thermoset insulation such as XLPE or XHHW-2 from the VFD to motor.
- It is preferred to use VFD cable, service wire company or equal, between the VFD and the motor per manufacturer's instructions.
- It is preferred to use continuous metal conduit to the VFD starter to the motor.
- If non-metallic conduit is used, VFD cable must be used.
- If using VFD cable in metal conduit, the metal conduit must be insulated at the motor, so that the metal conduit is not a continuous run.
- Always use flexible metallic liquid-tight conduit to feed the motor from metallic conduit.
- Grounding conductor must run from the VFD ground terminals directly to the motor conduit box. Always use proper grounding techniques (Star Method) and sized according to the NFPA 70 NEC.
- Always use bonding bushings on all conduit ends,
- Always use bonding bushings on all conduit ends, with proper size braided copper cable bonded to the starter panel.
- All grounding and bonding conductors and lugs must terminate on bare metal and not to painted surfaces.
- Always use a minimum of 3% impedance line reactor such as MTE or equal.
- Where the cables to the motor are longer than 50', always use a load reactor (customer must provide Vilter with cable lengths from feeder to starter and from starter to motor).
- Where the cables to the motor are longer than 500', always use a DV/DT load filter (customer must provide Vilter with cable lengths from feeder to starter and from starter to motor).
- Where the cables to the motor are longer than 1000', always use a sine filter (customer must provide Vilter with cable lengths from feeder to starter and from starter to motor).
- Line and load conductors must be separated, as much as the starter cabinet will allow, and cannot be in the same conduit or cable chase.
- By no means shall power and control cables run in parallel - cables must be separated, as much as the starter cabinet will allow, and cannot be in the same conduit or cable chase.
- For analog signals, use twisted shielded control cable rated for 600V.
- When a generator is feeding a VFD starter, use a 5% line reactor.
- Some countries require RFI/EMI filters -- please consult country codes and standards.
- As an insurance policy against motor shaft currents, use a split ring bearing protection ring on the motor shaft with the non-load bearing insulated.

Section 2 • Operational Descriptions

Overview

The following are typically controlled and monitored on all blower packages:

- Suction Pressure (Blower) – Pressure of the gas measured at the inlet of the blower.
- Discharge Pressure (Blower) – Pressure of the gas at the outlet of the blower.
- Suction Temperature – Temperature of the gas measured at the inlet of the blower.
- Discharge Temperature – Temperature of the gas at the outlet of the blower.
- Main Motor Amperage – Current draw by the main motor.
- Blower Motor Speed (Can control up to 4 blowers)
- Selectable groups of setpoints for varying operating conditions

The following are additional software controls available that are native to most blower packages controlled by the PLC:

- Monitoring of Instrument Data, Alarms, Trips, and Machine Status by DCS/Central Controller
- Blower Capacity suction or discharge pressure control setpoint from DCS/Central Controller
- Control of Individual Blower speeds from DCS/Central Controller
- Capacity pressure control on External Pressure Transducer data from DCS/Central Controller
- Control of Local/Remote from DCS/Central Controller
- Local and Remote Starting and Stopping of the Individual Blower Units

The following are optional blower unit-specific items that can be controlled or monitored:

- Main Motor Winding Temperatures
- Main Motor Bearing Temperatures
- Oil Pressure Safety Switch
- Air Cooled Oil Cooler Fan
- External Electric Oil Pump

The following are optional blower unit and package items that can be controlled or monitored:

- Aftercooler
 - Air Cooled Step Type
 - Air Cooled VFD Type
 - Water Cooled
- Inlet Scrubber
 - Pressure Drop across vessel
 - Condensate Drain
 - Low/High Level Safety Switches
- Outlet Scrubber
 - Pressure Drop across vessel
 - Condensate Drain
 - Low/High Level Safety Switches
- Discharge Recycle Valve

Operational Descriptions and Diagrams

CONFIGURATION OF THE BLOWER PACKAGE

The Blower package PLC can control up to 4 blowers. The blowers can be independently configured to run on a fixed speed setpoint, PID Control (variable speed), or taken out of service:

- Fixed Speed: In auto mode, individual blowers can be configured to run on 1 of 4 fixed speeds.
- Variable Speed: The individual blower's speed will be controlled by a PID controller to hold a suction or discharge pressure setpoint. If multiple blowers are configured to run on PID control, all will run off of a common speed command from the PID controller.
- Out of Service: Individual blowers may be taken out of service for demand considerations or maintenance. When a blower is out of service, alarms, trips, and status messages specific to that blower will not be generated.

Additionally, individual blowers may be enabled and disabled “on the fly,” either locally or remotely (by communications) without having to take them out of service.

Functions such as anti-recycle, and selected alarms and trips are blower specific, meaning if active, they apply only to the affected blower. This way if one blower trips or is in anti-recycle, the other blowers are allowed to run.

At start, the blowers may be configured to start offset from each other, to lessen the burden on the electrical infrastructure due to motor inrush.

STARTING OF THE BLOWER/PERMISSIVES

To run the blower package, it must be started from the “Start Menu” screen on the control panel HMI. Pressing “Unit Start” in the “Start Menu” screen will initiate a start if all permissives to initiate a start are met. To initiate a start, the following conditions must be met:

- Control Power is ON (Emergency Stop button is not pressed and Master Control Relay is energized, indicated by pilot light on front of panel)
- Blower Configuration is valid
- No Active General Trips (trips that apply to the whole blower package)

NOTE

If an individual blower trips, in order to restart blower, it must first clear trip condition and be re-enabled locally at the control panel.

When a start is initiated, the blower package will start if all permissives to run are met. If all permissives to run

are not met, the control will wait in a “standby” mode until all conditions to run are satisfied. Any condition that the control is waiting on is annunciated on the overview and menu screens and logged in the Event List. For the blowers to start running, the following must be met:

- Control Power is ON (Emergency Stop button is not pressed and Master Control Relay is energized, indicated by pilot light on front of panel)
- No Active General Trips
- Blower Package start has been initiated by pressing “Unit Start” in the “Start Menu” screen.
- Remote Permissive input is ON
- Soft run permissive from the DCS/Central Controller is ON (if control by communications selected)
- Blower Anti-Recycle Timer is not active (specific to each blower – each blower has its own anti-recycle function.)
- No Blower-Specific Trips Active (specific to each blower)

ANTI-RECYCLE

After a blower motor stops, it is not allowed to re-start again for a settable time. This is to protect the blower motor. If the Anti-Recycle timer is active, a banner will appear next to the specific blower on the main screen that shows the remaining time. If a start is initiated, the blower state indicator will indicate “Standby” until the Anti-Recycle timer is done. If all other permissives are met, the blower will re-start when its anti-recycle timer expires. In multiple-blower applications, the anti-recycle function is blower specific – one or more blowers may be in anti-recycle without affecting the operation of other blowers on the package.

AUTOMATIC SPEED CONTROL

For blowers that are configured to run on PID speed control, a PID controller will adjust the speed of the blowers to hold a pressure set point. Two control methods are available:

- Discharge Pressure Control: Blower increases speed to increase discharge Pressure to desired setpoint
- Suction Pressure Control: Blower increases speed to lower suction pressure to desired setpoint

Any blowers configured to run on PID speed control receive the same speed command from the PID controller. Blowers configured to run on fixed speed control will maintain their fixed speed set point. Variables that factor in to the automatic speed control are the following:

- Target pressure – the desired suction or discharge pressure the blower package will try to maintain.

Section 2 • Operational Descriptions

- Deadband – Range above and below target pressure where no speed adjustment will be made.
- Proportional Gain (Kp) – Proportional Term of the PID equation
- Integral Gain (Ki) – Integral term of the PID equation
- Derivative Gain (Kd) – Derivative Gain of the PID equation.

OPERATING MODES

The speed control of the blower package can be configured to operate in several ways, depending on the needs of the site. This mode selection is made at the “Start Menu” screen. There are four basic modes, described below:

- Local-Auto: The blower controller will adjust the speed of the blowers to maintain the target pressure set point. The target pressure setpoint is set on the local HMI. Blowers will run off of the PID controller’s speed command or fixed speed set point, according to how the individual blowers are configured.
- Local-Manual: The operator is in control of the individual blower speeds from the local HMI. When in Local-Manual mode, the operator controls the speed of each blower by adjusting the manual speed set points on the blower overview screen.
- Remote-Auto: The blower controller will adjust the speed of the blowers to maintain the target pressure set point. Blowers will run off of the PID controller’s speed command or fixed speed set point, according to how the individual blowers are configured. The target pressure setpoint is defined by the DCS/Central Controller via communications. (NOTE: Control by Communications must be enabled to use this mode.)
- Remote-Manual: Individual blower speed commands are controlled by a DCS or Central Controller via communications. (NOTE: Control by Communications must be enabled to use this method.)

In any of the above modes, all local alarms and trips will still apply.

For safety reasons, remote mode is only enabled if Control by Communications is enabled.

In the event that the communications link between the blower PLC and the central controller/DCS is lost, the action taken is selectable from the Configuration screen. The machine will Trip or revert to Local mode and continue to run depending on the selection.

The blower PLC can be remotely commanded to Local or Remote Mode if Control by Communications is enabled.

LOAD LIMITS AND FORCED UNLOADING

Reference example, Figure 2-1

To protect the blower package and process, the controller will inhibit the blower from increasing speed or force it to decrease speed if certain variables get outside of set ranges. Load limits and forced unloading will also affect blowers that are configured to PID speed control. The load limiting variable depends on what control mode the blower package is in.

- In Discharge Pressure Control, the load limiting will be controlled by suction pressure.
- In Suction Pressure Control, the load limiting will be controlled by discharge pressure.

Three set points are used to control load limits and forced unloading:

- Inhibit Loading: when this setpoint is reached, the blower will not be allowed to increase speed
- Unload at: when this setpoint is reached, the blower motor will decrease speed by a settable rate (forced unload) until the “Unload To” setpoint is reached.
- Unload To: this is the setpoint at which the blower motor will stop decreasing speed from a forced unload condition.

When a load limit or forced unload condition is active it will be annunciated in the status banner on the overview and menu HMI screens, and will also be logged in the event list.

SAFETIES

The blower controller continuously monitors operational and process data and annunciates an alarm and/or stops the machine if any condition becomes abnormal. Two levels of safeties exist when an abnormal condition is detected.

- Alarm: If active, alarms are annunciated on the blower HMI. When activated, a popup screen showing the date and time of the alarm and alarm message will appear. Alarms are also logged in the Event List. An alarm serves only as a warning to the operator; if an alarm is active the machine is still allowed to run.
- Trip: If active, trips will shut the machine down or not allow the blower to start. Trips are annunciated on the blower HMI. When activated, a popup screen showing the date and time of the trip and trip message will appear. Trips are also logged in the Event List.

Alarms and Trips may be general or blower-specific. A general trip will shut down the entire blower package, a blower-specific trip will only shut down the affected

Section 2 • Operational Descriptions

blower. If a blower shuts down due to a blower-specific trip, other blowers that do not have active trips will be allowed to run.

The “Alarm Reset” pushbutton on the overview screen will reset any active alarms or trips if the abnormal condition has been removed.

For a comprehensive list of alarms and trips and possible causes, see the troubleshooting guide in this manual.

The “Alarm Reset” pushbutton on the overview screen will reset any active alarms or trips if the abnormal

condition has been removed.

For a comprehensive list of alarms and trips and possible causes, see the troubleshooting guide in this manual.

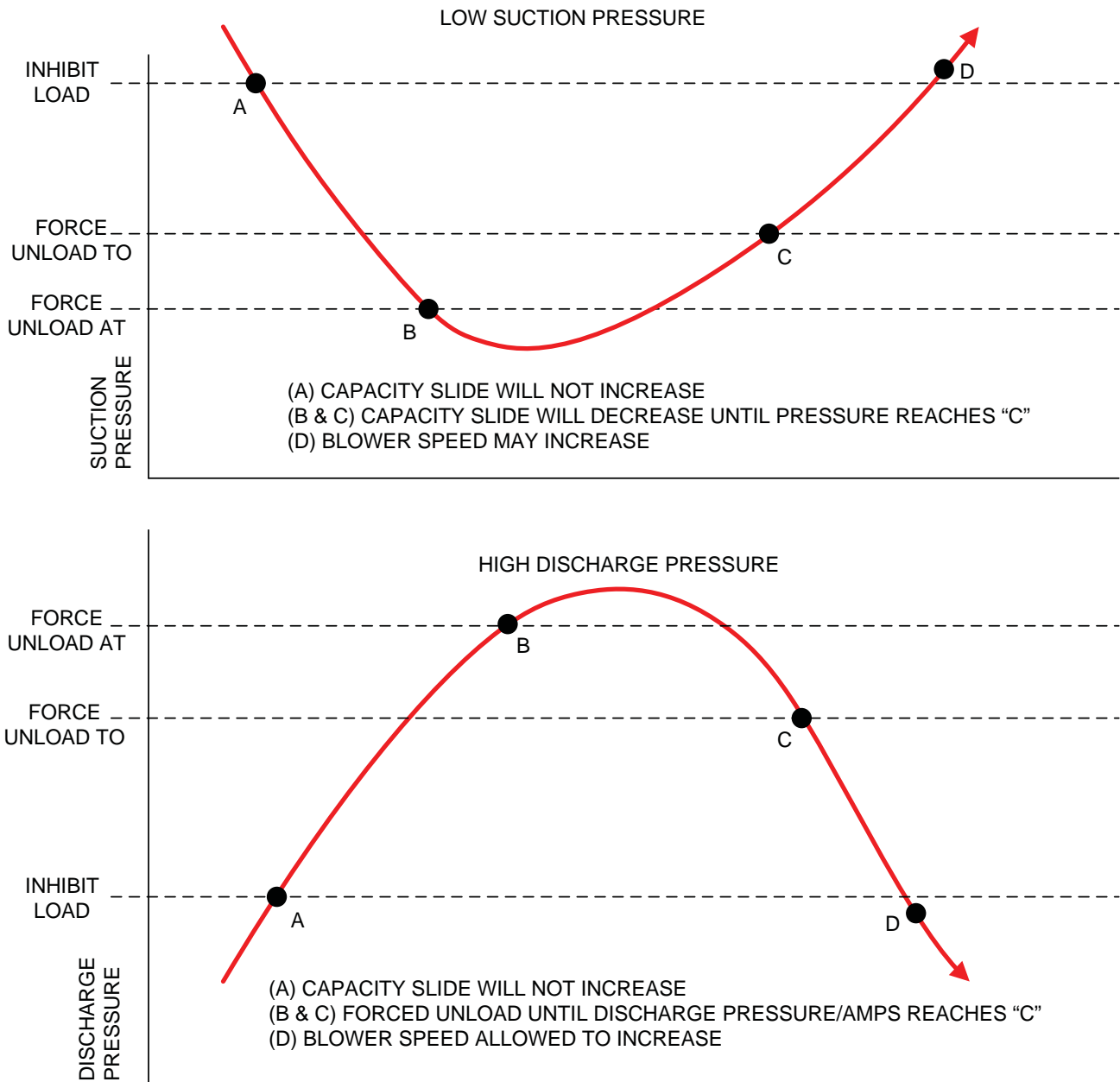

Figure 2-1. Operational Diagram - Load Limits / Forced Unloading (Example)

Section 2 • Operational Descriptions

EMERGENCY STOP

Reference Figure 2-2

The Emergency Stop circuit in the blower control panel energizes the Master Control Relay, which provides power to PLC outputs that control actuators, heaters, motor starters, valves, etc. The Master Control Relay may be energized by pressing the “Control Power On” illuminated pushbutton on the door of the blower control panel. When the Master Control Relay is energized, the “Control Power On” pushbutton will illuminate. The following conditions must be satisfied to energize the Master Control Relay:

- Emergency Stop pushbutton on the door of the blower control panel must be pulled out.

- Any additional Emergency stops or safety devices tied in to the Emergency Stop circuit must be reset.
- The blower PLC must be booted up and operational.
- The 24-volt DC power supplies in the blower control panel must be powered up and OK.

SUPPLEMENTAL BLOWER MOTOR PROTECTION

In the event that the controller detects a blower motor running when it is not being commanded to run by the controller, the controller will energize a blower-specific supplemental shutdown output. This output can be used to control a shunt trip, under-voltage release, isolation contactor, or other safety power removal device.

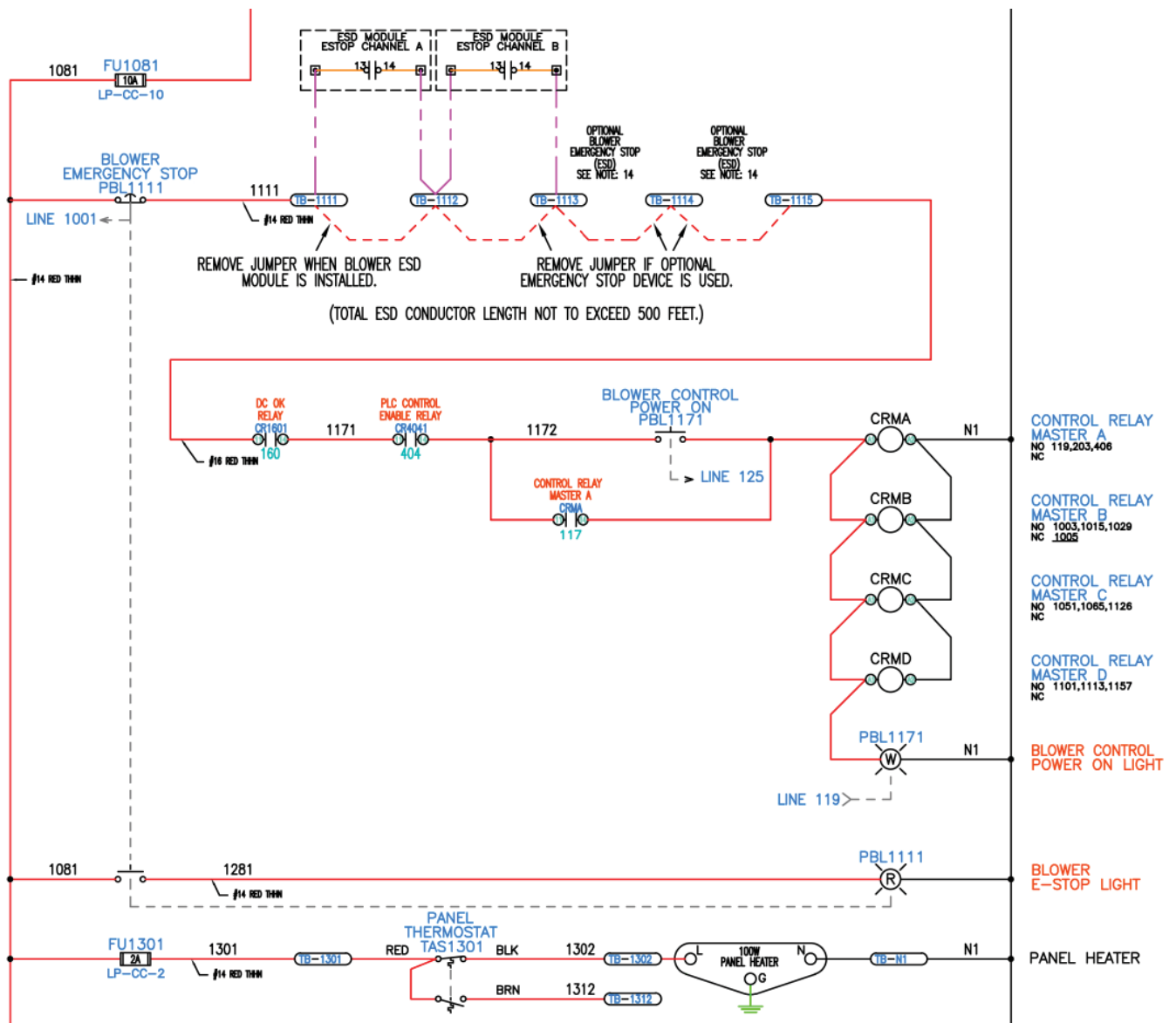

Figure 2-2. Control Panel Master Power and Emergency Stop Electrical Circuit

Section 2 • Operational Descriptions

AIR COOLED OIL COOLER FAN

If installed, the air-cooled oil cooler fan starts with the blower motor and runs as long as the blower motor is running.

EXTERNAL ELECTRIC OIL PUMP

If installed, the external electric oil pump starts with the blower motor and runs as long as the blower motor is running.

OIL PRESSURE SAFETY SWITCH

If installed, the oil pressure safety switch will shut down the blower if oil pressure is lost.

AIR COOLED AFTERCOOLER – STEP TYPE

If installed, the step type air-cooled aftercooler is a heat exchanger that uses multiple fans to remove heat from the gas discharged from the blowers. The number of fans that run is determined by the gas temperature at the outlet of the aftercooler.

The controller starts and stops fans in a sequence to control the gas temperature at the outlet of the aftercooler. When the aftercooler outlet temperature exceeds

the desired temperature plus a deadband, fans will be turned on after a time delay to add more cooling. When aftercooler outlet temperature drops below the desired temperature minus a deadband, fans will be turned off after a time delay.

- When the blower package is stopped, all aftercooler fans are turned off.
- When the blower package is running and the aftercooler outlet temperature rises above the “Start Aftercooler At” temperature set in the “Step Type Aftercooler Setpoints” screen, the first fan (or group of fans) will start.
- When the blower package is running and the aftercooler outlet temperature is above the deadband, a fan (or group of fans) will start each time through the “Step Dwell Time.”
- When the blower package is running and the aftercooler outlet temperature is below the deadband, a fan (or group of fans) will stop each time through the “Step Dwell Time.”
- Once started, the first fan or group of fans will remain running until the blower stops.

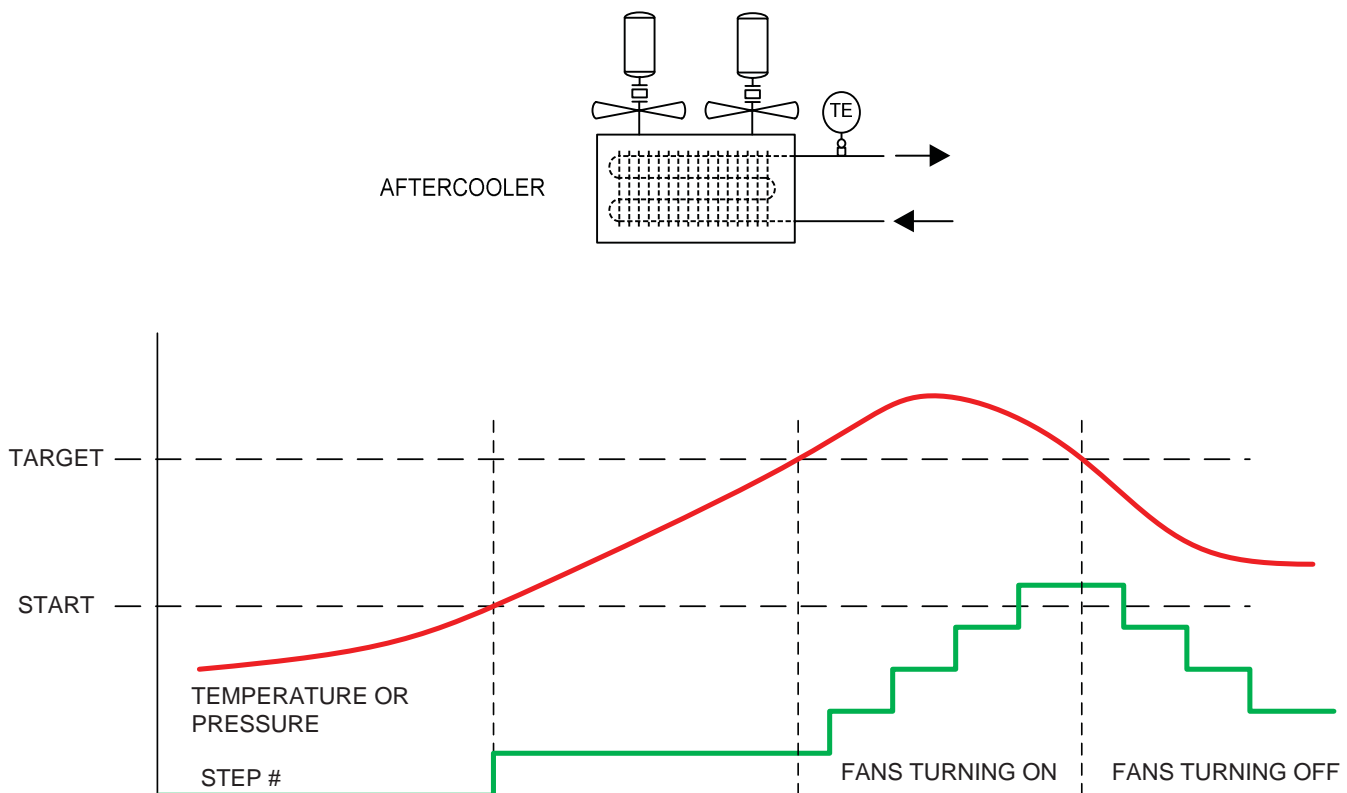

Figure 2-3. Operational Diagram - Air Cooled Aftercooler (Step Type)

Section 2 • Operational Descriptions

AIR COOLED AFTERCOOLER – VFD TYPE

If installed, the VFD type air cooled aftercooler is a heat exchanger that uses one or more fans running on a VFD to remove heat from the gas discharged from the blowers. The VFD speeds up or slows down the fan motor to control the amount of cooling done by the aftercooler.

A PID controller adjusts the speed of the fan(s) to maintain the outlet gas temperature of the aftercooler. When the aftercooler outlet temperature exceeds the desired temperature plus a deadband, the fan(s) will increase speed to add more cooling. When aftercooler outlet temperature drops below the desired temperature minus a deadband, the fan(s) will decrease speed.

- When the blower package is stopped, the aftercooler fan(s) will stop.
- When the blower package is running and the gas aftercooler outlet temperature rises above the “Start Aftercooler At” set in the “VFD Type Aftercooler Setpoints” screen, the fan(s) will start at a settable

minimum speed.

- When the blower package is running and the aftercooler outlet temperature is above the deadband, the PID controller will increase fan speed.
- When the blower package is running and the aftercooler outlet temperature is below the deadband, the PID controller will decrease fan speed.

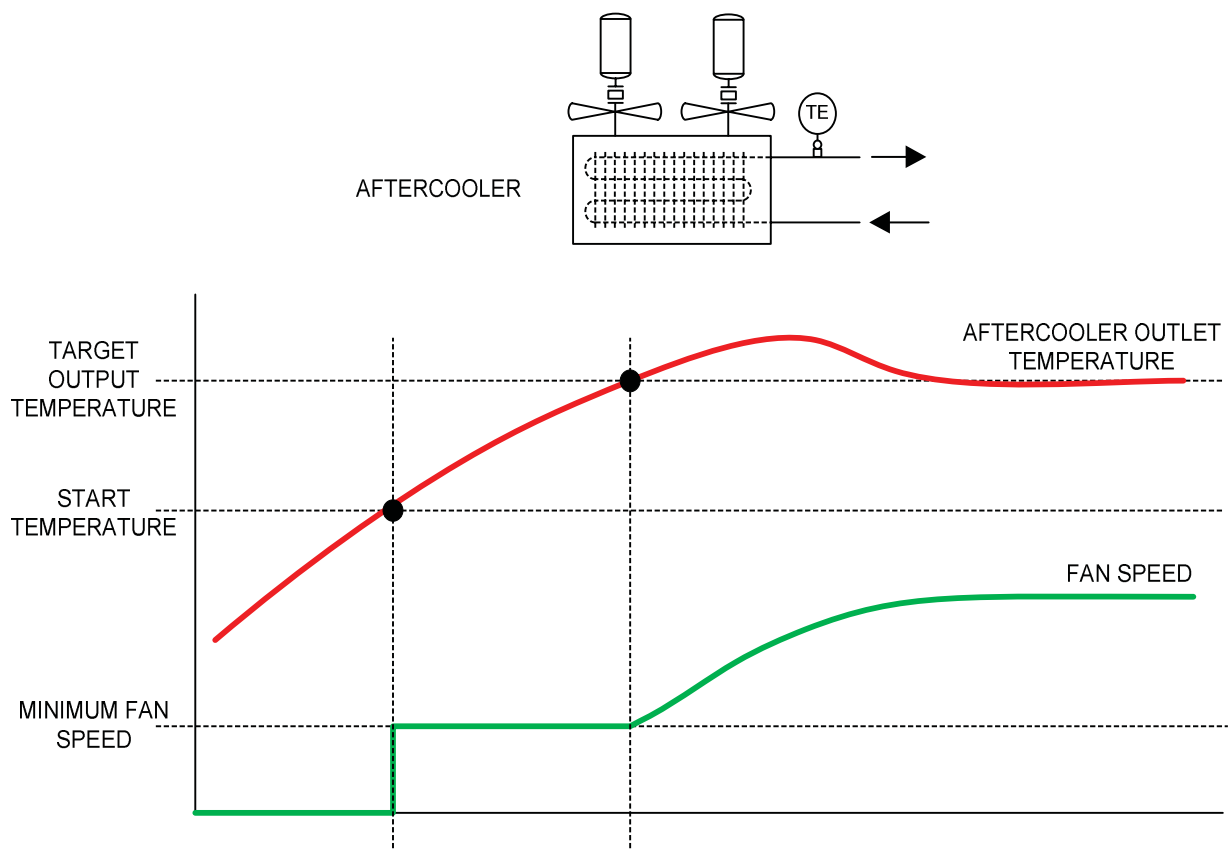

Figure 2-4. Operational Diagram - Air Cooled Aftercooler (VFD Type)

Section 2 • Operational Descriptions

WATER COOLED GAS AFTERCOOLER

If installed, the water-cooled gas aftercooler is a heat exchanger that uses a modulating valve to control cooling water flow to remove heat from the gas discharged by the blowers. The valve position is adjusted to control the amount of cooling done by the aftercooler.

A PID controller adjusts the opening degree of the modulating valve to maintain a desired temperature at the outlet of the gas aftercooler. When the aftercooler outlet temperature exceeds the desired pressure plus a deadband, the valve will open further to add more cooling. When aftercooler outlet temperature drops below the desired temperature minus a deadband, the valve will begin to close.

- When the blower package is stopped, the valve will be commanded to 0% open (full close).
- When the blower package is running and the aftercooler out temperature rises above the “Open Valve At” setpoint in the “Water Cooled Aftercooler Setpoints” screen, the valve will open to a settable minimum position.

- When the blower is running and the aftercooler outlet temperature is above the deadband, the PID controller will increase the valve opening degree.
- When the blower is running and the aftercooler outlet temperature is below the deadband, the PID controller will decrease the valve opening degree.

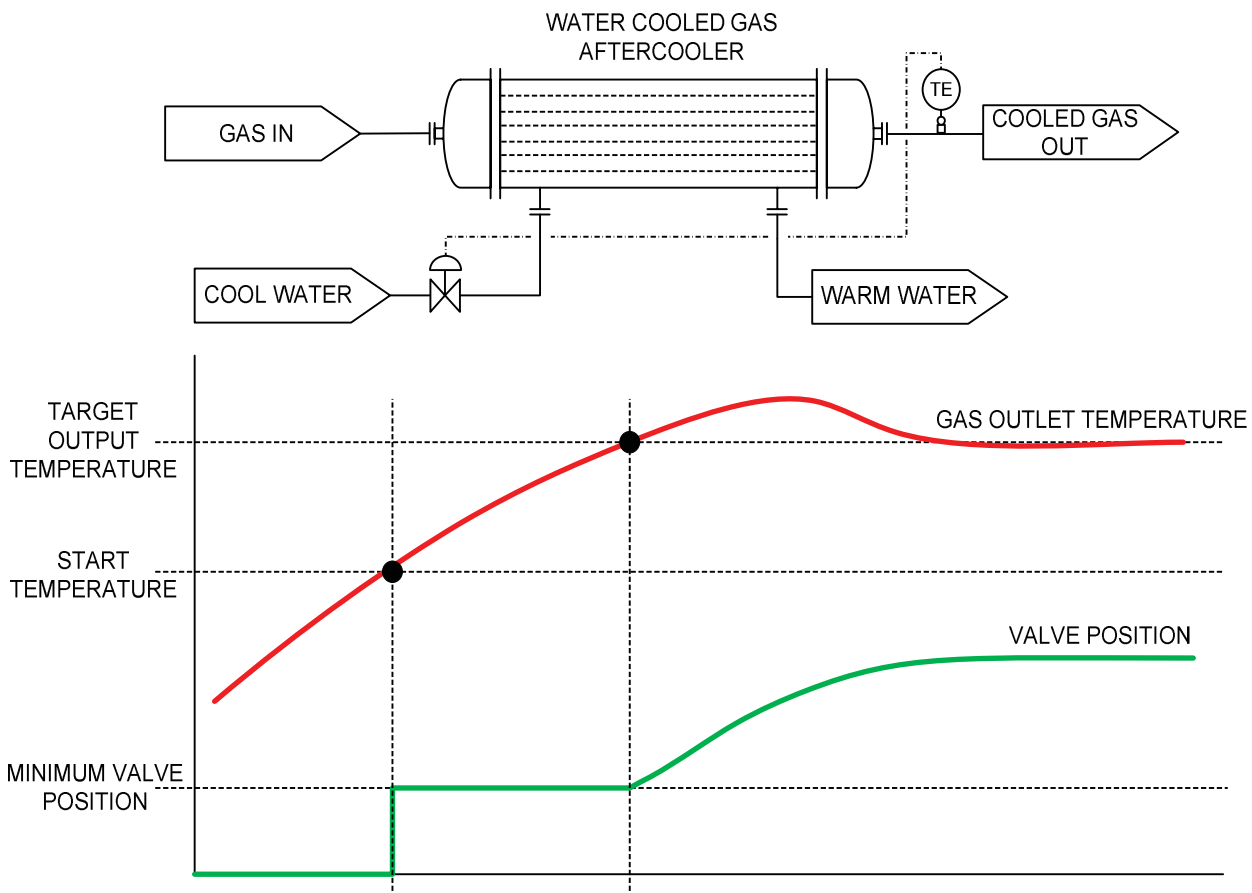

Figure 2-5. Operational Diagram - Water Cooled Gas Aftercooler

Section 2 • Operational Descriptions

GAS SCRUBBERS

A gas scrubber (or knockout drum) is a vessel with a vane pack and/or coalescing elements installed to remove moisture and other contaminants from the gas stream. Gas scrubbers may be installed on the suction side or discharge side of a blower package (if an aftercooler is used, the scrubber is installed downstream of the aftercooler). A condensate pump or solenoid valve drains accumulated moisture from the vessel.

Gas scrubbers include the following devices:

- Pressure transducers on the inlet and outlet of the vessel – used to measure pressure drop across the demister pad or coalescing elements to help determine when to clean or replace.
- Level switches to monitor the condensate level:
 - LSH (High Level) – when liquid level reaches the LSH level switch, an alarm is annunciated on the blower HMI.
 - LSHH (High High Level) – when liquid level reaches the LSHH level switch, an alarm or trip is annunciated on the blower HMI. The alarm or trip action is configurable depending on the site and location of the vessel. If trip action is selected, the blower will shut down if the LSHH is activated. Typically the purpose of the LSHH is to alarm or shut down the blower package to prevent bringing liquid into the blower suction.
- LSL (Low Level) – when liquid level drops below the LSL level switch, an alarm or trip is annunciated on the blower HMI. The alarm or trip action is configurable depending on the site and location of the vessel. If trip action is selected, the blower will shut down if the LSL is activated. Typically the purpose of the LSL is to detect if the liquid seal is lost to prevent introducing gas into the condensate drain system.
- Condensate Drain System:
 - A drain pump or solenoid valve will turn on when the liquid level in the scrubber reaches the “Cutin” level switch.
 - The drain pump or solenoid valve will turn off when the liquid level in the scrubber drops to the “Cutout” level switch.
 - Dual pumps may be used. Selection of Pump A or B is made in the Configuration screen.

Section 2 • Operational Descriptions

DISCHARGE RECYCLE VALVE

If installed, the discharge recycle valve is a motorized or air actuated valve that recycles discharge gas back to the suction of the blower package. The valve acts as a regulator, opening to maintain the set pressure in the discharge line.

A PID controller adjusts the opening degree of the valve to maintain a desired pressure on the high pressure side of the valve. When the recycle control pressure exceeds the desired pressure plus a deadband, the valve will start to open to recycle high pressure gas back to suction.

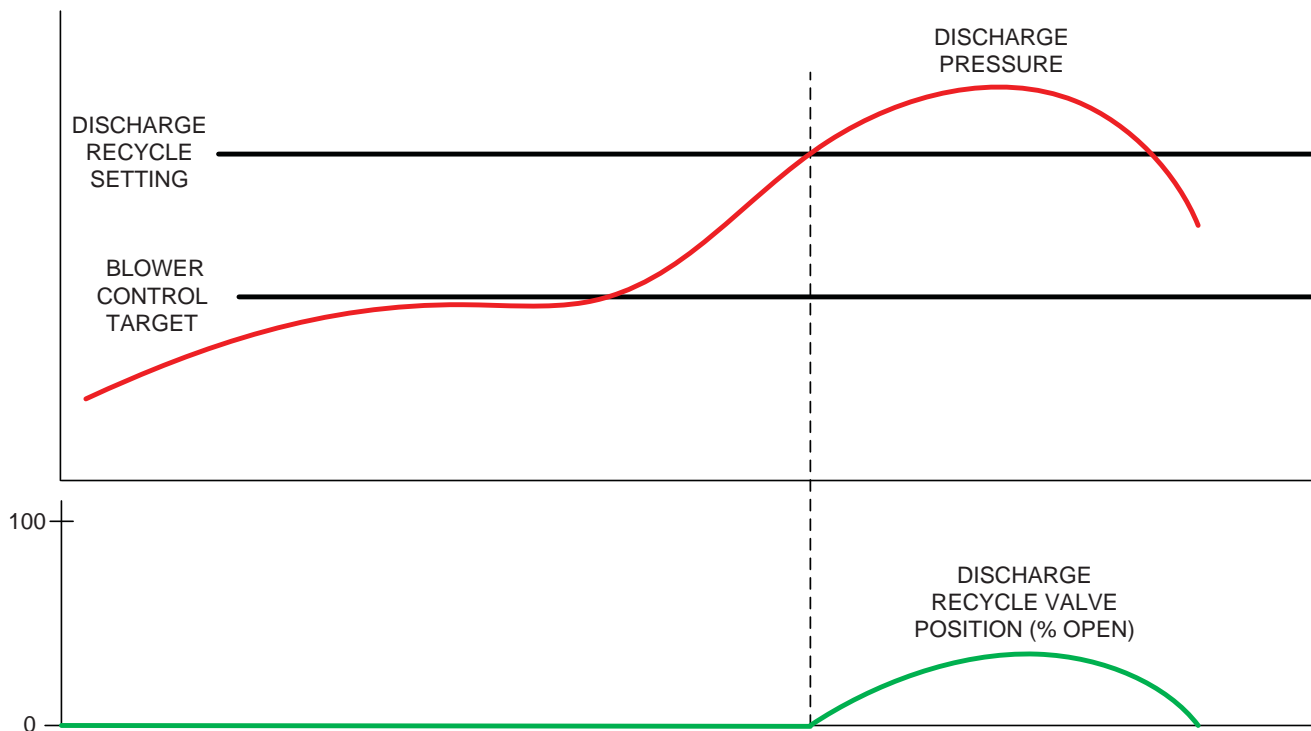

Figure 2-6. Operational Diagram - Discharge Recycle Valve

Blower and System Overview Screens

The blower and system overview screens shows blower status, configuration, any active alarms or trips, and live process data. The blower and/or process are displayed in a format similar to a P&ID diagram with live process data shown on the screen.

From the blower and system overview screens, all other screens are accessed by pressing the “Main Menu” goto screen button in the lower right of the screen. The system overview display is accessed from the blower overview screen and vice-versa, if a system overview screen is displayed.

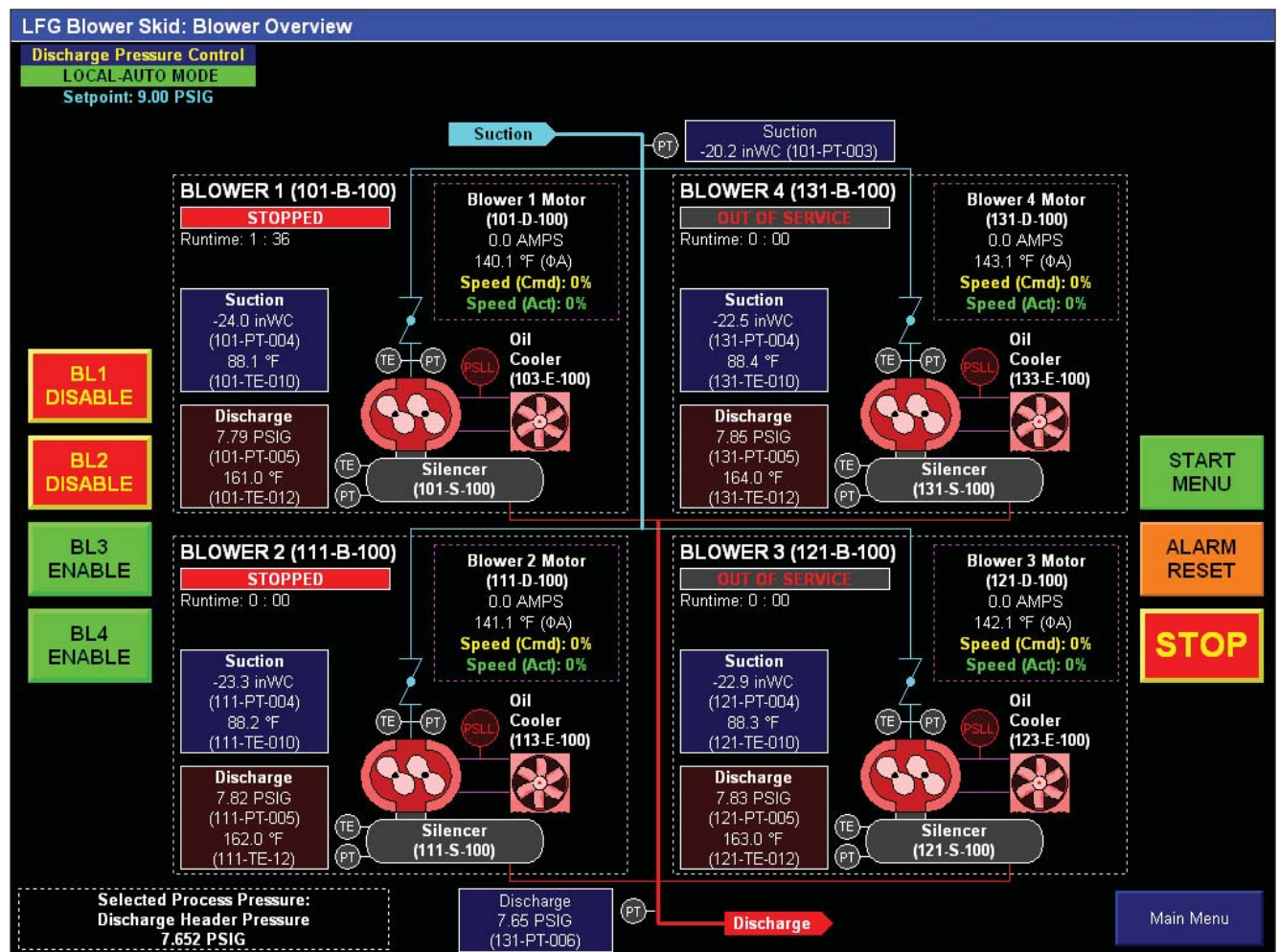

Figure 3-1. Basic Blower Package Screen

Section 4 • HMI Navigation

Main Menu Screen

HMI screens are accessed by using the navigation buttons on each screen. When the HMI boots up, the blower overview screen is displayed by default. The HMI Screens are divided into groups, all of which are accessible from the Main Menu Screen.

The Main Menu Screen allows the user to view basic blower configuration, status, active alarms and trips, as well as navigate to configuration, control, calibration, and diagnostics screens.

An electronic copy of the blower PLC manual is accessed from the Main Menu Screen.

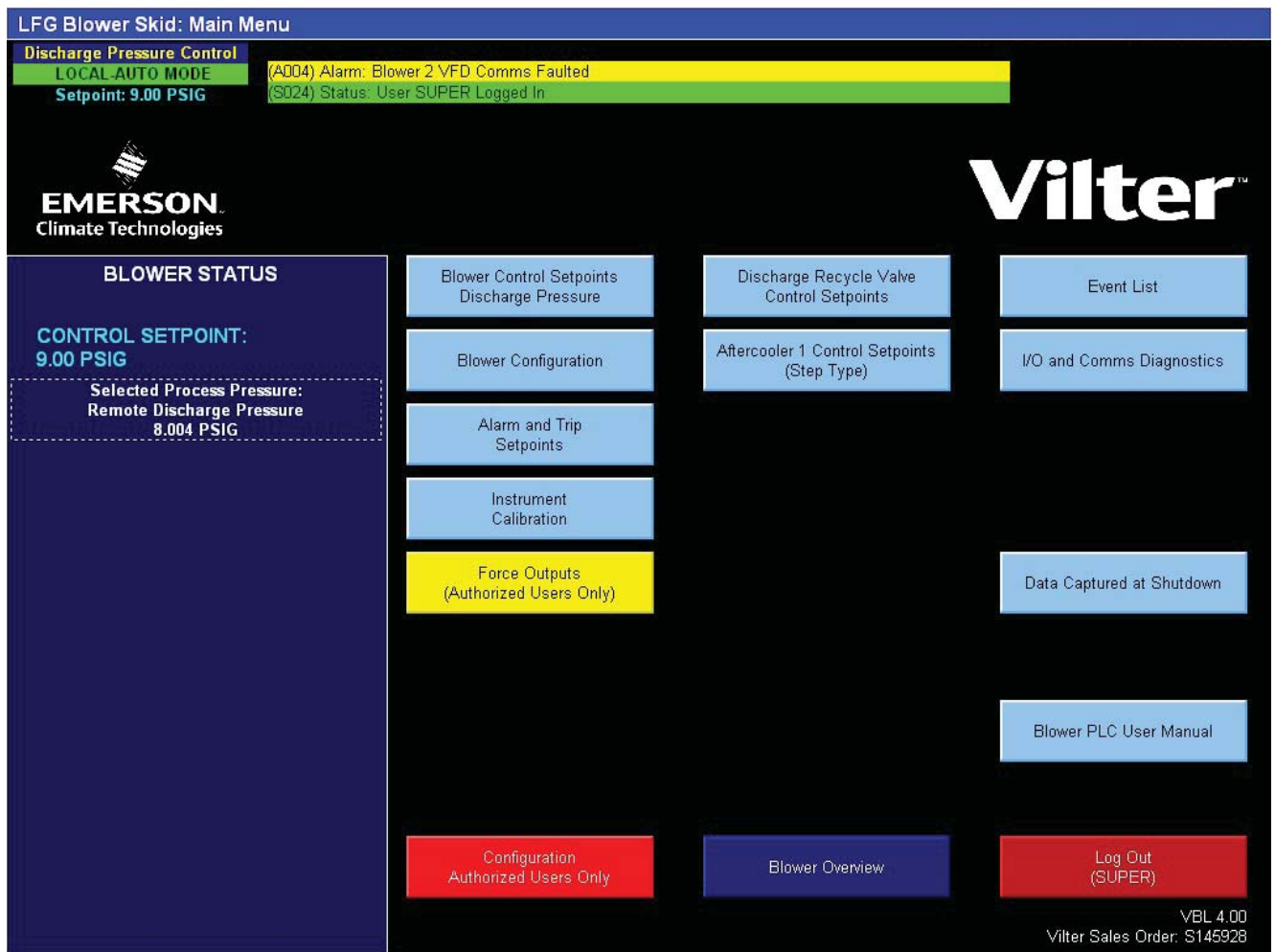

Figure 4-1. Main Menu Screen

Section 4 • HMI Navigation

HMI Security

Some items and screens on the HMI require a login to be viewed or changed.

Login accounts are described below, each with its default password and level of access.

DEFAULT

- This is the user account that is active when the HMI boots up or the user logs out of another user account.
- Permissions:
 - May start and stop the machine
 - May change Remote-Local and Auto-Manual modes
 - May view setpoints, calibration data, and diagnostics

OP1, OP2, OP3, OP4, OP5

- These user accounts are intended for operators.
- Default Password: 1
- Permissions
 - May start and stop the machine
 - May change Remote-Local and Auto-Manual modes
 - May Operate the machine in Manual mode
 - May view setpoints, calibration data, and diagnostics
 - May change setpoints

SUPER

- This user account is intended for site supervisors, managers, and superintendents.
- Default Password: 1
- Permissions
 - May start and stop the machine
 - May change Remote-Local and Auto-Manual modes
 - May Operate the machine in Manual mode
 - May view setpoints, calibration data, and diagnostics
 - May change setpoints
 - May force Discrete and Analog outputs on the PLC
 - May make changes to machine configuration selections

LOGGING IN

To log on, press the “Log On” button. The “Log On” button is located in the Upper-Right corner of most screens, and in the lower right corner of the menu screen. The login popup screen will appear, shown in Figure 4-3. Enter User Name and password using the popup keyboard.

It is recommended to log out when finished. Every login is recorded in the blower control’s event list. After 10 minutes of inactivity, the HMI will automatically log out the current user.

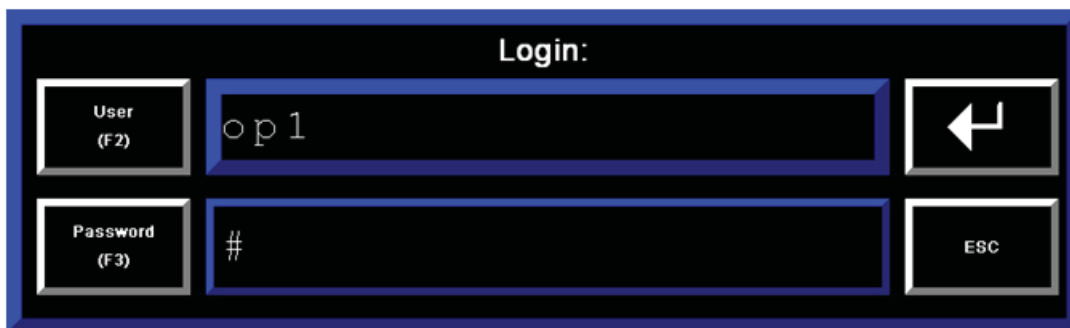

Figure 4-2. Login Popup Screen

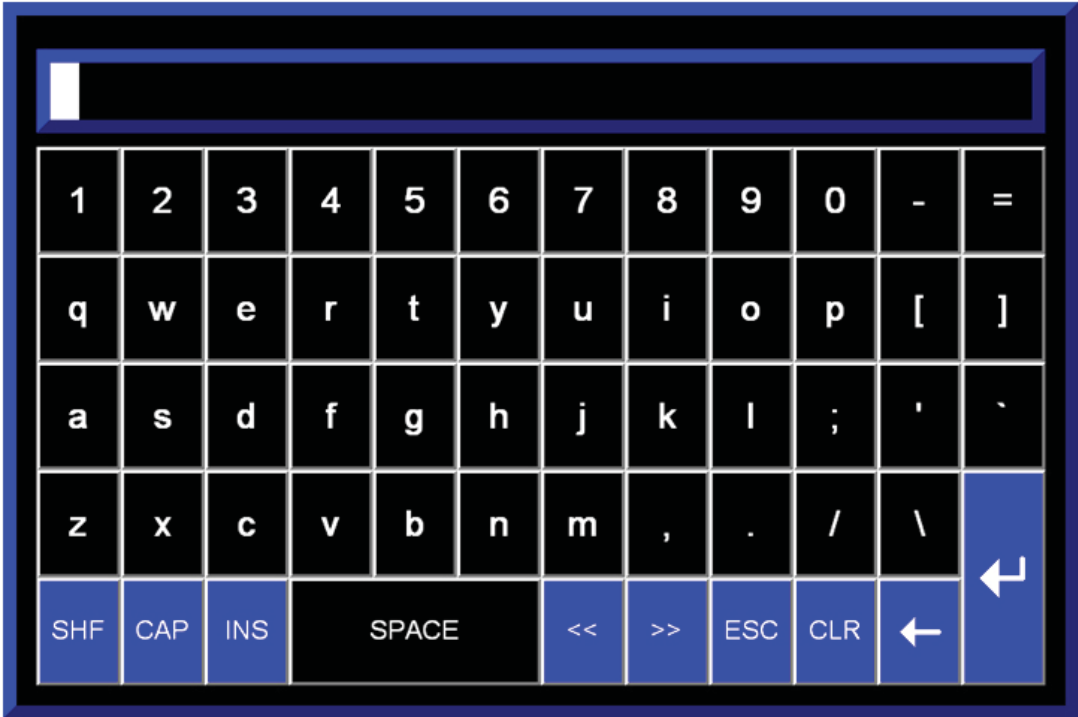

Figure 4-3. Login Screen Keyboard

Section 5 • Configuration - Supervisor Level

Configuration Screen - Supervisor Level

NOTE

Some screens may have inverted colors for ease of readability.

Most of the configuration that is specific to the blower package is completed at the factory and not accessible to the user. The options that may be configured by the

user are included on this screen. To change option selections, press on the list selector and use the up, down, and enter buttons on the lower side of the screen.

LFG Blower Skid: Configuration - Authorized Users ONLY

DATE AND TIME
HMI: **Thursday, August 22, 2013 2:47:32 PM**
PLC (24 hr format): **08/22/2013 14:46:43**
Set Date and Time
Note: HMI Date and Time will automatically synchronize with PLC Date and Time

REMOTE OPERATION
Enable Control by Communications
Control by Communication Disabled
Control by Communication Enabled
Watchdog Time:
5 Seconds
Communication Fault Action
Alarm and Revert to Local Mode
Trip Machine

INLET SCRUBBER - PUMP A/B
Condensate Pump Select
Pump A
Pump B

OUTLET SCRUBBER - PUMP A/B
Condensate Pump Select
Pump A
Pump B

Log Out (SUPER)

PanelView Configuration
PanelView Shutdown
Change Password
Initial Running Data
Device Names
Back to Menu

▲ ▼ ◀

Figure 5-1. Configuration Screen - All Options Shown (Supervisor Level)

Section 5 • Configuration - Supervisor Level

DATE AND TIME

Allows the Real Time Clock in the PLC to be set. Pressing “Set Date and Time” will bring up the “Set Date and Time” popup screen.

- Date and Time must be set in 24-hour format.
- Pressing “Set Date and Time” will set the PLC time clock.
- The HMI time clock will automatically synchronize to the PLC time clock.

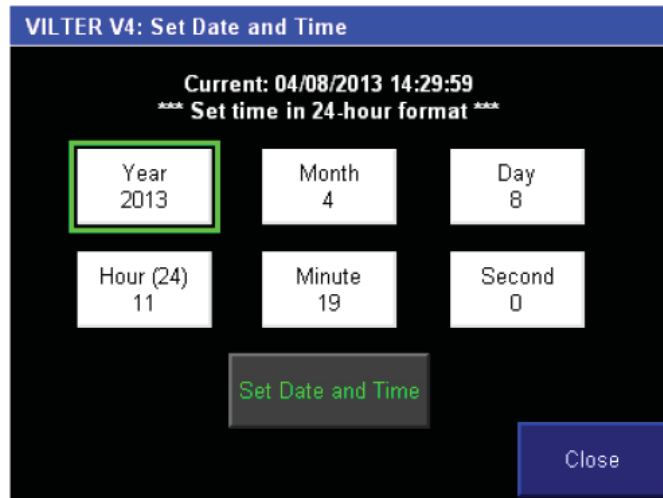

Figure 5-2. Set Date/Time Pop-Up Screen - Supervisor Level

REMOTE OPERATION

For the blower control to accept commands from a DCS or Central Controller, Control by Communications must be enabled. For more details on remote operation, see Section 12, Communication with DCS/Central Controller.

- Control by Communications
 - If enabled, allows a central controller/DCS to send commands to the blower PLC
 - If disabled, allows a central controller/DCS to read data only.
- Communications Watchdog and Communication Fault Action
 - The settable watchdog time defines the amount of time a loss in communications can be detected before triggering a communication fault
 - Action taken on communication fault is selectable:
 - Alarm and Revert to local mode – The blower controller will generate an alarm, and change mode to local-auto. The machine will continue to run (if running) in local mode.
 - Trip Machine – Communication Fault will shut the machine down.

MOTOR RTDs

Selects if Motor Winding and Bearing Temperatures are being monitored by the controller.

INLET / OUTLET SCRUBBER PUMP A / B

If the inlet and/or outlet scrubbers include dual condensate pumps, this selection determines which pump is active.

CHANGE PASSWORD

Pressing the “Change Password” button opens the “Change Password” pop-up screen, see Figure 5-3 To change a password on an account, the user must be logged in under that account.

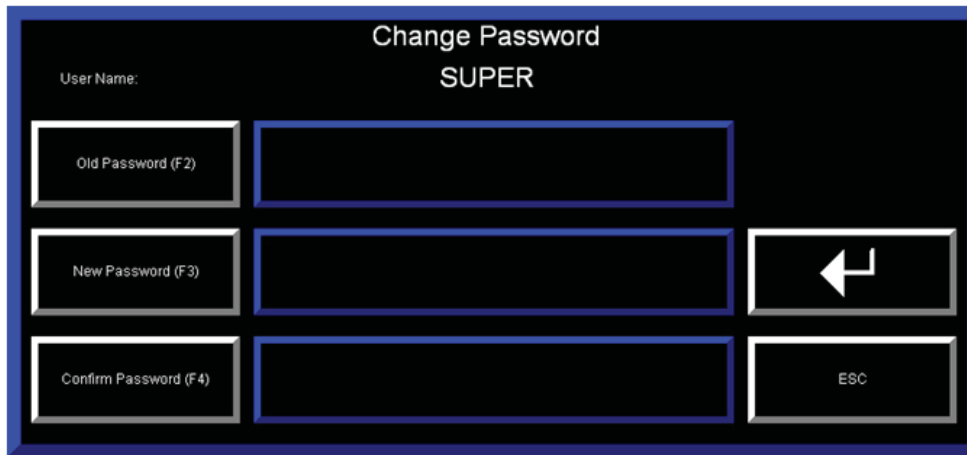

Figure 5-3. Change Password Pop-Up Screen - Supervisor Level

PANELVIEW CONFIGURATION

Pressing the “Panelview Configuration” button closes the blower control application running on the HMI and opens the Factory Talk View ME Station configuration screens.

INITIAL RUNNING DATA

Pressing the “Initial Running Data” Button opens the Initial Running Data Screen which shows baseline data logged when the blower was new. See Section X “Diagnostics Screens” for more information.

DEVICE NAMES

Pressing the “Device Names” button navigates to the Define Device Names screens. See “Define Device Names” later in this section for more information.

BACK TO MENU

Pressing the “Back to Menu” button navigates back to the main menu screen.

Section 5 • Configuration - Supervisor Level

Editing Device Names

The “Device Names” group of screens allows a user logged in as “SUPER” to edit names shown on the screen identifying blower unit and package equipment, instrumentation, and alarm and trip designations. To edit the text fields in this group of screens, press on the string input button and use the popup keyboard to edit the text.

Typically, the device names entered in this group of screens are the designations for each device, instrument, or alarm that relate it back to the P&ID diagram.

The “Device Names” group of screens is divided into three sections, see Figure 5-3.

DEVICES AND VESSELS

In Figure 5-4, this screen the user may edit device names shown on the screen for devices, vessels, and equipment installed on the blower package.

The user may navigate to other screens within the “Define Device Names” group by using the navigation buttons on the right side of the screen.

LFG Blower Skid: Define Device Names - Devices and Vessels			
Machine Name	LFG Blower Skid	Blower 4	131-B-100
		Blower 4 Motor	131-D-100
Blower 1	101-B-100	Blower 4 Silencer	131-S-100
Blower 1 Motor	101-D-100	Blower 4 Oil Cooler	133-E-100
Blower 1 Silencer	101-S-100		
Blower 1 Oil Cooler	103-E-100	Inlet Scrubber	101-V-300
		Outlet Scrubber	111-V-100
Blower 2	111-B-100	Discharge Recycle Valve	101-PV-520
Blower 2 Motor	111-D-100	Aftercooler 1	101-E-200
Blower 2 Silencer	111-S-100		
Blower 2 Oil Cooler	113-E-100		
Blower 3	121-B-100		
Blower 3 Motor	121-D-100		
Blower 3 Silencer	121-S-100		
Blower 3 Oil Cooler	123-E-100		

Log Out (SUPER)

Instrument Names
Alarm and Trip Names

Back to Menu

Figure 5-4. Define Device Names - Devices and Vessels (Supervisor Level)

Section 5 • Configuration - Supervisor Level

INSTRUMENTATION

In Figure 5-5, this screen allows the user to edit device names shown on the screen for instrumentation installed on the blower unit or package.

LFG Blower Skid: Define Device Names - Instrumentation - 1					
INSTRUMENTATION					Log Out (SUPER)
Inlet Scrubber Inlet Pressure		Blower 1 ODE Bearing Temperature	107-TE-001		
Inlet Scrubber Outlet Pressure		Blower 1 DE Bearing Temperature	107-TE-005	Blower 3 Discharge Pressure	121-PT-005
Outlet Scrubber Inlet Pressure				Blower 3 Motor Amps	VFD-003B
Outlet Scrubber Outlet Pressure		Blower 2 Suction Temperature	111-TE-010	Blower 3 Phase A Temperature	127-TE-002
Suction Header Pressure	101-PT-003	Blower 2 Discharge Temperature	111-TE-12	Blower 3 Phase B Temperature	127-TE-003
Discharge Header Pressure	131-PT-006	Blower 2 Suction Pressure	111-PT-004	Blower 3 Phase C Temperature	127-TE-004
Aftercooler Outlet Temperature	101-TE-200	Blower 2 Discharge Pressure	111-PT-005	Blower 3 ODE Bearing Temperature	127-TE-001
Recycle Control Pressure	111-PT-300	Blower 2 Motor Amps	VFD-003C	Blower 3 DE Bearing Temperature	127-TE-005
		Blower 2 Phase A Temperature	117-TE-002		
Blower 1 Suction Temperature	101-TE-010	Blower 2 Phase B Temperature	117-TE-003		
Blower 1 Discharge Temperature	101-TE-012	Blower 2 Phase C Temperature	117-TE-004		Instrument Names - 2
Blower 1 Suction Pressure	101-PT-004	Blower 2 ODE Bearing Temperature	117-TE-001		Device Names
Blower 1 Discharge Pressure	101-PT-005	Blower 2 DE Bearing Temperature	117-TE-005		Alarm and Trip Names
Blower 1 Motor Amps	VFD-003D				
Blower 1 Phase A Temperature	107-TE-002	Blower 3 Suction Temperature	121-TE-010		
Blower 1 Phase B Temperature	107-TE-003	Blower 3 Discharge Temperature	121-TE-012		
Blower 1 Phase C Temperature	107-TE-004	Blower 3 Suction Pressure	121-PT-004		
					Back to Menu

Figure 5-5. Define Device Names - Instrumentation (Supervisor Level)

Section 5 • Configuration - Supervisor Level

ALARM AND TRIP

In Figure 5-6, this screen allows the user to edit the alarm and trip designation text that appears in the alarm and trip banners, alarm pop-up screen, and event list.

In addition, messages for 5 user-defined alarms and trips may be defined on this screen.

LFG Blower Skid: Define Device Names - Alarm and Trip - 1						
	ALARM	TRIP		ALARM	TRIP	
Emergency Stop		ESD-100	Blower 2 High Phase B Temperature	TAH-003	TAHH-003	Log Out (SUPER)
Low Suction Header Pressure	PAL-003	PALL-003	Blower 2 High Phase C Temperature	TAH-004	TAHH-004	
High Discharge Header Pressure	PAH-300	PAHH-300	Blower 2 High ODE Bearing Temperature	TAH-001	TAHH-001	
Blower 1 High Discharge Temperature	TAH-012	TAHH-012	Blower 2 High DE Bearing Temperature	TAH-005	TAHH-005	
Blower 1 High Discharge Pressure	PAH-005	PAHH-005	Blower 2 High Motor Amps	IAH-003C	IAHH-003C	
Blower 1 Low Suction Pressure	PAL-004	PALL-004	Blower 2 Oil Pressure Safety		PAL(L)-001	
Blower 1 High Phase A Temperature	TAH-002	TAHH-002				
Blower 1 High Phase B Temperature	TAH-003	TAHH-003	Blower 3 High Discharge Temperature		TAHH-012	
Blower 1 High Phase C Temperature	TAH-004	TAHH-004	Blower 3 High Discharge Pressure	PAH-005		
Blower 1 High ODE Bearing Temperature	TAH-001	TAHH-001	Blower 3 Low Suction Pressure	PAL-004	PALL-004	
Blower 1 High DE Bearing Temperature	TAH-005	TAHH-005	Blower 3 High Phase A Temperature	TAH-002	TAHH-002	
Blower 1 High Motor Amps	IAH-003D	IAHH-003D	Blower 3 High Phase B Temperature	TAH-003		NEXT
Blower 1 Oil Pressure Safety		PAL(L)-001	Blower 3 High Phase C Temperature	TAH-004	TAHH-004	Device Names
			Blower 3 High ODE Bearing Temperature	TAH-001	TAHH-001	Instrument Names
Blower 2 High Discharge Temperature	TAH-012	TAHH-012	Blower 3 High DE Bearing Temperature	TAH-005	TAHH-005	
Blower 2 High Discharge Pressure	PAH-005	PAHH-005	Blower 3 High Motor Amps	IAH-003B	IAHH-003B	
Blower 2 Low Suction Pressure	PAL-004	PALL-004	Blower 3 Oil Pressure Safety		PAL(L)-001	Back to Menu
Blower 2 High Phase A Temperature	TAH-002	TAHH-002				

Figure 5-6. Define Device Names - Alarm and Trip 1 (Supervisor Level) (1 of 2)

Section 5 • Configuration - Supervisor Level

LFG Blower Skid: Define Device Names - Alarm and Trip - 2						
	ALARM	TRIP		ALARM	TRIP	
Blower 4 High Discharge Temperature	TAH-012	TAHH-012	Outlet Scrubber High Level (Vane)	LAH-301	LAHH-300	Log Out (SUPER)
Blower 4 High Discharge Pressure	PAH-005	PAHH-005	Outlet Scrubber Low Level (Vane)		LAL-301	
Blower 4 Low Suction Pressure	PAL-004	PALL-004	Upper Outlet Scrubber High Level (Coalescing)			
Blower 4 High Phase A Temperature	TAH-002	TAHH-002	Lower Outlet Scrubber High Level (Coalescing)			
Blower 4 High Phase B Temperature	TAH-003	TAHH-003	High Outlet Scrubber Pressure Drop			
Blower 4 High Phase C Temperature	TAH-004	TAHH-004	User Defined Alarm 1	USER ALARM 1		
Blower 4 High ODE Bearing Temperature	TAH-001	TAHH-001	User Defined Alarm 2	USER ALARM 2		
Blower 4 High DE Bearing Temperature	TAH-005	TAHH-005	User Defined Alarm 3	USER ALARM 3		
Blower 4 High Motor Amps	IAH-003A	IAHH-003A	User Defined Alarm 4	USER ALARM 4		
Blower 4 Oil Pressure Safety		PAL(I)-001	User Defined Alarm 5	USER ALARM 5		
Inlet Scrubber High Level (Vane)	LAH-301	LAHH-300	User Defined Trip 1	USER TRIP 1		BACK
Inlet Scrubber Low Level (Vane)		LAL-301	User Defined Trip 2	USER TRIP 2		Device Names
Upper Inlet Scrubber High Level (Coalescing)			User Defined Trip 3	USER TRIP 3		Instrument Names
Lower Inlet Scrubber High Level (Coalescing)			User Defined Trip 4	USER TRIP 4		
Inlet Scrubber High Pressure Drop			User Defined Trip 5	USER TRIP 5		Back to Menu

Figure 5-7. Define Device Names - Alarm and Trip 2 (Supervisor Level) (2 of 2)

Calibration Main Screen

NOTE

Some screens may have inverted colors for ease of readability.

Pressing the “Instrument Calibration” navigation button on the menu screen opens the instrument calibration group of screens. This group of screens allows the user to view and edit calibration data for specific instruments installed on the blower unit or package.

From the main menu, pressing the “Instrument

Calibration” button navigates to the calibration overview screen. The calibration overview screen shows information related to all instruments installed on the blower unit or package, including their raw values, base units (used internally in the program) and as displayed. Calibration of specific instruments is accessed using the navigation buttons on the right side of the screen.

LFG Blower Skid: Instrument Calibration - Overview (1 of 2)

Name:	Description:	Raw:	Base Units:	Displayed:
	Inlet Scrubber Inlet Pressure:	9.080 mA	14.19 PSIA	-13.978 inWC
	Inlet Scrubber Outlet Pressure:	9.070 mA	14.16 PSIA	-14.752 inWC
	Outlet Scrubber Inlet Pressure:	12.080 mA	22.57 PSIA	7.875 PSIG
	Outlet Scrubber Outlet Pressure:	12.070 mA	22.54 PSIA	7.848 PSIG
101-PT-003	Suction Header Pressure:	9.000 mA	13.97 PSIA	-20.164 inWC
131-PT-006	Discharge Header Pressure:	12.000 mA	22.36 PSIA	7.652 PSIG
101-TE-200	Aftercooler 1 Outlet Temperature:	136.000 °F	136.0 °F	136.0 °F
111-PT-300	Recycle Control Pressure:	12.010 mA	22.38 PSIA	7.680 PSIG
101-TE-010	Blower 1 Suction Temperature:	88.100 °F	88.1 °F	88.1 °F
101-TE-012	Blower 1 Discharge Temperature:	161.000 °F	161.0 °F	161.0 °F
101-PT-004	Blower 1 Suction Pressure:	8.950 mA	13.83 PSIA	-24.030 inWC
101-PT-005	Blower 1 Discharge Pressure:	12.050 mA	22.49 PSIA	7.792 PSIG
VFD-003D	Blower 1 Motor Amps:	4.000 mA	--	0 AMPS
107-TE-002	Blower 1 Phase A Temperature:	140.100 °F	140.1 °F	140.1 °F
107-TE-003	Blower 1 Phase B Temperature:	140.200 °F	140.2 °F	140.2 °F
107-TE-004	Blower 1 Phase C Temperature:	140.300 °F	140.3 °F	140.3 °F
107-TE-001	Blower 1 ODE Bearing Temperature:	90.100 °F	90.1 °F	90.1 °F
107-TE-005	Blower 1 DE Bearing Temperature:	90.200 °F	90.2 °F	90.2 °F
111-TE-010	Blower 2 Suction Temperature:	88.200 °F	88.2 °F	88.2 °F
111-TE-12	Blower 2 Discharge Temperature:	162.000 °F	162.0 °F	162.0 °F
111-PT-004	Blower 2 Suction Pressure:	8.960 mA	13.86 PSIA	-23.257 inWC
111-PT-005	Blower 2 Discharge Pressure:	12.060 mA	22.52 PSIA	7.820 PSIG
VFD-003C	Blower 2 Motor Amps:	4.000 mA	--	0 AMPS
117-TE-002	Blower 2 Phase A Temperature:	141.100 °F	141.1 °F	141.1 °F
117-TE-003	Blower 2 Phase B Temperature:	142.100 °F	142.1 °F	142.1 °F
117-TE-004	Blower 2 Phase C Temperature:	143.100 °F	143.1 °F	143.1 °F
117-TE-001	Blower 2 ODE Bearing Temperature:	91.100 °F	91.1 °F	91.1 °F
117-TE-005	Blower 2 DE Bearing Temperature:	91.200 °F	91.2 °F	91.2 °F

Log On (DEFAULT)

Calibrate Pressures

Calibrate Temperatures

Other Analog Calibration

NEXT

Back to Menu

Figure 6-1. Instrument Calibration Overview Screen

Section 6 • Instrument Calibration

Pressure Calibration Screen

In Figure 6-2, the temperature calibration group of screens allows the user to change the pressure units displayed on the screen as well as calibrate pressure instruments.

Pressure units are specific to individual pressure instruments. Changing the pressure display units for a transducer also converts all pressure setpoints related to that transducer to the new selected units.

The following pressure units are available for display:

- PSIG (Pounds/square inch gage)
- PSIA (Pounds/square inch absolute)
- kPa[A] (Kilopascals absolute)
- kPa[G] (Kilopascals gage)
- kg/cm2[A] (Kilograms/square centimeter absolute)
- kg/cm2[G] (Kilograms/square centimeter gage)
- inHg (inches of mercury) – Vacuum is shown in inHg, positive pressure is shown in PSIG
- inWC (gage)
- Bar[A] (absolute)
- Bar[G] (gage)
- Torr[A] (absolute)
- Torr[G] (gage)

LFG Blower Skid: Pressure Calibration - 1 of 3

Blower 1 Suction Pressure (101-PT-004) Raw: 8.950 mA XDCR: 1.768 inHg (13.828 PSIA) Displayed: -24.030 inWC	Display kg/cm ² [G] inHg inWC Bar[A]	Transducer kg/cm ² [A] kg/cm ² [G] inHg inWC	Raw Min 4.000 mA Raw Max 20.000 mA	XDCR Min -29.921 inHg XDCR Max 30.000 PSIG	Offset 0.000 inHg[D]
Blower 1 Discharge Pressure (101-PT-005) Raw: 12.050 mA XDCR: 7.792 PSIG (22.488 PSIA) Displayed: 7.792 PSIG	PSIG PSIA kPa[A] kPa[G]	kg/cm ² [A] kg/cm ² [G] inHg inWC	Raw Min 4.000 mA Raw Max 20.000 mA	XDCR Min -29.921 inHg XDCR Max 30.000 PSIG	Offset 0.000 inHg[D]
Blower 2 Suction Pressure (111-PT-004) Raw: 8.960 mA XDCR: 1.711 inHg (13.856 PSIA) Displayed: -23.257 inWC	kg/cm ² [G] inHg inWC Bar[A]	kg/cm ² [A] kg/cm ² [G] inHg inWC	Raw Min 4.000 mA Raw Max 20.000 mA	XDCR Min -29.921 inHg XDCR Max 30.000 PSIG	Offset 0.000 inHg[D]
Blower 2 Discharge Pressure (111-PT-005) Raw: 12.060 mA XDCR: 7.820 PSIG (22.516 PSIA) Displayed: 7.820 PSIG	PSIG PSIA kPa[A] kPa[G]	kg/cm ² [A] kg/cm ² [G] inHg inWC	Raw Min 4.000 mA Raw Max 20.000 mA	XDCR Min -29.921 inHg XDCR Max 30.000 PSIG	Offset 0.000 inHg[D]
Blower 3 Suction Pressure (121-PT-004) Raw: 8.965 mA XDCR: 1.682 inHg (13.870 PSIA) Displayed: -22.871 inWC	kg/cm ² [G] inHg inWC Bar[A]	kg/cm ² [A] kg/cm ² [G] inHg inWC	Raw Min 4.000 mA Raw Max 20.000 mA	XDCR Min -29.921 inHg XDCR Max 30.000 PSIG	Offset 0.000 inHg[D]
Blower 3 Discharge Pressure (121-PT-005) Raw: 12.065 mA XDCR: 7.834 PSIG (22.530 PSIA) Displayed: 7.834 PSIG	PSIG PSIA kPa[A] kPa[G]	kg/cm ² [A] kg/cm ² [G] inHg inWC	Raw Min 4.000 mA Raw Max 20.000 mA	XDCR Min -29.921 inHg XDCR Max 30.000 PSIG	Offset 0.000 inHg[D]

Log Out (SUPER)

Notes on Pressure Calibration:
 Must be logged in to calibrate pressures.
 Transducer Units: Units the instrument is calibrated in.
 Display Units: Units that will be displayed on the screen.
 Raw Min/Max: Min Scale and Full Scale raw values from transducer (Typically 4-20 mA)
 XDCR Min/Max: Min Scale and Full Scale values in transducer units.
 Offset: Adds an offset to the calibrated value in transducer units (does not affect Target Value).
 Target Value: Entering a known pressure in transducer units will calculate an offset.
 Differential Pressures will be displayed in the Selected units on the screen.

▲

▼

Enter ↵

NEXT

Calibration Main

Back to Menu

Figure 6-2. Pressure Calibration Screen - 1 of 3

Section 6 • Instrument Calibration

CALIBRATE PRESSURE INSTRUMENT

To calibrate a pressure instrument, proceed with the following steps:

1. Select the units that the transducer is calibrated in. For example, for a transducer calibrated 0-200 PSIA, the transducer units selected shall be 'PSIA.' For a transducer calibrated -30inHg to 30PSIG, the transducer units selected shall be "inHg."
2. Select the units that the pressure will be displayed in on the HMI.
3. Enter the raw mA range (typically 4-20mA)
4. Enter the Span of the instrument. For a 0-200 PSIA transducer, Enter "0" for XDCR Min and "200" for XDCR Max.

CALIBRATE TRANSDUCER TO A KNOWN PRESSURE

There are two options when calibrating a transducer to a known pressure.

NOTE

Differential pressures does not require calibration, but the differential pressure display units can be selected.

OPTION 1

1. Open the pressure transducer to a known pressure.
2. Adjust the Offset value until the "Displayed" value is equal to the known pressure.

OPTION 2

1. Open the pressure transducer to a known pressure.
2. Enter the known pressure (in transducer units) into "Target Value." The controller will calculate an offset based on the known pressure that was entered.

LFG Blower Skid: Pressure Calibration - 3 of 3

Suction Header Pressure (101-PT-003) Raw: 9.000 mA XDCR: 1.483 inHg (13.967 PSIA) Displayed: -20.164 inWC	Display kg/cm ² [G] inHg inWC Bar[A]	Transducer kg/cm ² [A] kg/cm ² [G] inHg inWC	Raw Min 4.000 mA Raw Max 20.000 mA	XDCR Min -29.921 inHg XDCR Max 30.000 PSIG	Offset 0.000 inHg[D]	Log Out (SUPER)
Notes on Pressure Calibration: Must be logged in to calibrate pressures. Transducer Units: Units the instrument is calibrated in. Display Units: Units that will be displayed on the screen. Raw Min/Max: Min Scale and Full Scale raw values from transducer (Typically 4-20 mA) XDCR Min/Max: Min Scale and Full Scale values in transducer units. Offset: Adds an offset to the calibrated value in transducer units (does not affect Target Value). Target Value: Entering a known pressure in transducer units will calculate an offset. Differential Pressures will be displayed in the Selected units on the screen.						
Discharge Header Pressure (131-PT-006) Raw: 12.000 mA XDCR: 7.652 PSIG (22.348 PSIA) Displayed: 7.652 PSIG	Display PSIG PSIA kPa[A] kPa[G]	Transducer kg/cm ² [A] kg/cm ² [G] inHg inWC	Raw Min 4.000 mA Raw Max 20.000 mA	XDCR Min -29.921 inHg XDCR Max 30.000 PSIG	Offset 0.000 inHg[D]	
Discharge Recycle Control (111-PT-300) Raw: 12.010 mA XDCR: 7.680 PSIG (22.376 PSIA) Displayed: 7.680 PSIG	Display PSIG PSIA kPa[A] kPa[G]	Transducer kg/cm ² [A] kg/cm ² [G] inHg inWC	Raw Min 4.000 mA Raw Max 20.000 mA	XDCR Min -29.921 inHg XDCR Max 30.000 PSIG	Offset 0.000 inHg[D]	

Inlet Scrubber Pressure Drop: Base: 0.028 PSID Displayed: 0.028 PSID	PSID kPa[D] kg/cm ² [D] inHg[D]
Outlet Scrubber Pressure Drop: Base: 1.000 PSID Displayed: 1.000 PSID	PSID kPa[D] kg/cm ² [D] inHg[D]

▲
▼

Enter

↶

BACK

Calibration Main

Back to Menu

Figure 6-3. Pressure Calibration Screen - 3 of 3

Section 6 • Instrument Calibration

Temperature Calibration Screen

The temperature calibration group of screens allows the user to change the temperature units displayed on the screen as well as calibrate temperature instruments.

Four Temperature units are available for display:

- Fahrenheit
- Celsius or Centigrade
- Kelvin (Absolute Celsius temperature scale)
- Rankine (Absolute Fahrenheit temperature scale)

Temperature units can be changed by touching on the list selector in any temperature calibration screen and using the up, down, and enter buttons. Changing the temperature display units also converts all temperature setpoints to the new selected units.

CALIBRATE TEMPERATURE INSTRUMENTS

There two types of temperature instruments that can be calibrated, RTDs and temperature transmitters.

To calibrate an RTD, proceed with the following steps.

NOTE

Typically, RTDs are very accurate and do not require calibration.

1. Expose the RTD to a known temperature (such as a slurry of crushed ice and water).
2. Enter an offset so the displayed temperature is equal to the known temperature.

To calibrate a temperature transmitter, proceed with the following steps.

1. Enter the raw mA range (typically 4-20mA).
2. Enter the span of the transmitter in degrees Fahrenheit. For a 32-392 Fahrenheit transmitter, Enter “32” for XDCR Min and “392” for XDCR Max.

LFG Blower Skid: Temperature Calibration - 1 of 4

Instrument	Raw	Base	Displayed	Offset
Blower 1 Suction Temp. (101-TE-010)	88.100 °F	88.100 °F	88.100 °F	0.000 °F
Blower 1 Discharge Temp. (101-TE-012)	161.000 °F	161.000 °F	161.000 °F	0.000 °F
Blower 2 Suction Temp. (111-TE-010)	88.200 °F	88.200 °F	88.200 °F	0.000 °F
Blower 2 Discharge Temp. (111-TE-12)	162.000 °F	162.000 °F	162.000 °F	0.000 °F
Blower 3 Suction Temp. (121-TE-010)	88.300 °F	88.300 °F	88.300 °F	0.000 °F
Blower 3 Discharge Temp. (121-TE-012)	163.000 °F	163.000 °F	163.000 °F	0.000 °F

Displayed Temp Units:
Fahrenheit - °F
Celsius - °C
Kelvin - K
Rankine - °R

Log Out (SUPER)

Up, Down, Enter, Back

NEXT
Calibration Main
Back to Menu

Figure 6-4. Temperature Calibration Screen

Other Analog Device Calibration

The Other Analog Device Calibration Screen allows the user to calibrate additional 4-20mA input devices.

4-20mA devices that can be calibrated:

- Main Motor Amperage
- Main Motor VFD Speed

CALIBRATE AN ADDITIONAL INSTRUMENT

To calibrate an additional instrument, proceed with the following steps.

1. Enter the raw mA range (typically 4-20mA).
2. Enter the Span of the transmitter.
3. Enter minimum scale value in “XDCR Min” and full scale value for “XDCR Max.”

LFG Blower Skid: Other Analog Device Calibration

Blower 1 Motor Amps (VFD-003D) Raw: 4.000 mA Displayed: 0 Amps	Raw Min 4.000 mA	XDCR Min 0 Amps	Offset 0.00 Amps	Note on Motor Amps: Use the CT turns ratio value for XDCR Max if using a Current Transformer and Transducer. Example: Turns Ratio is 250:5, transducer converts 0-5 Amps to 4-20mA. Scaling is 0-250 Amps = 4-20mA, so enter 0 for XDCR Min and 250 for XDCR Max.	Log Out (SUPER)
	Raw Max 20.000 mA	XDCR Max 200 Amps			
Blower 2 Motor Amps (VFD-003C) Raw: 4.000 mA Displayed: 0 Amps	Raw Min 4.000 mA	XDCR Min 0 Amps	Offset 0.00 Amps		
	Raw Max 20.000 mA	XDCR Max 200 Amps			
Blower 4 Motor Amps (VFD-003A) Raw: 4.000 mA Displayed: 0 Amps	Raw Min 4.000 mA	XDCR Min 0 Amps	Offset 0.00 Amps		
	Raw Max 20.000 mA	XDCR Max 200 Amps			
Blower 3 Motor Amps (VFD-003B) Raw: 4.000 mA Displayed: 0 Amps	Raw Min 4.000 mA	XDCR Min 0 Amps	Offset 0.00 Amps		
	Raw Max 20.000 mA	XDCR Max 200 Amps			
					Calibration Main
					Back to Menu

Figure 6-5. Other Analog Calibration Screen

Setpoints and Control Screens

The setpoint and control screens relate to the operation and control of the blower. Process and operational setpoints for the blower and other equipment are adjustable within this group of screens.

CHANGING SETPOINTS

To change setpoints within the setpoint and control screens, the user must be logged in. Setpoints that may be adjusted by the logged in user appear as a white button that shows the current value of the setpoint. Setpoints that may not be adjusted by the logged in user (or if no user is logged in) appear as text only and cannot be changed.

Pressing on a numeric entry opens the numeric entry pop-up screen, see Figure 7-1.

- In Figure 7-1, the upper left text shows the current value of the setpoint.
- In Figure 7-1, the numeric entry pop-up screen, the range of values above the numerical buttons is the acceptable range that can be entered. If a value outside this range is entered the HMI will not accept it.
- To enter a new setpoint, use the numerical keypad and enter key.
- To close the numerical input pop-up screen without changing the setpoint, push the “ESC” key.

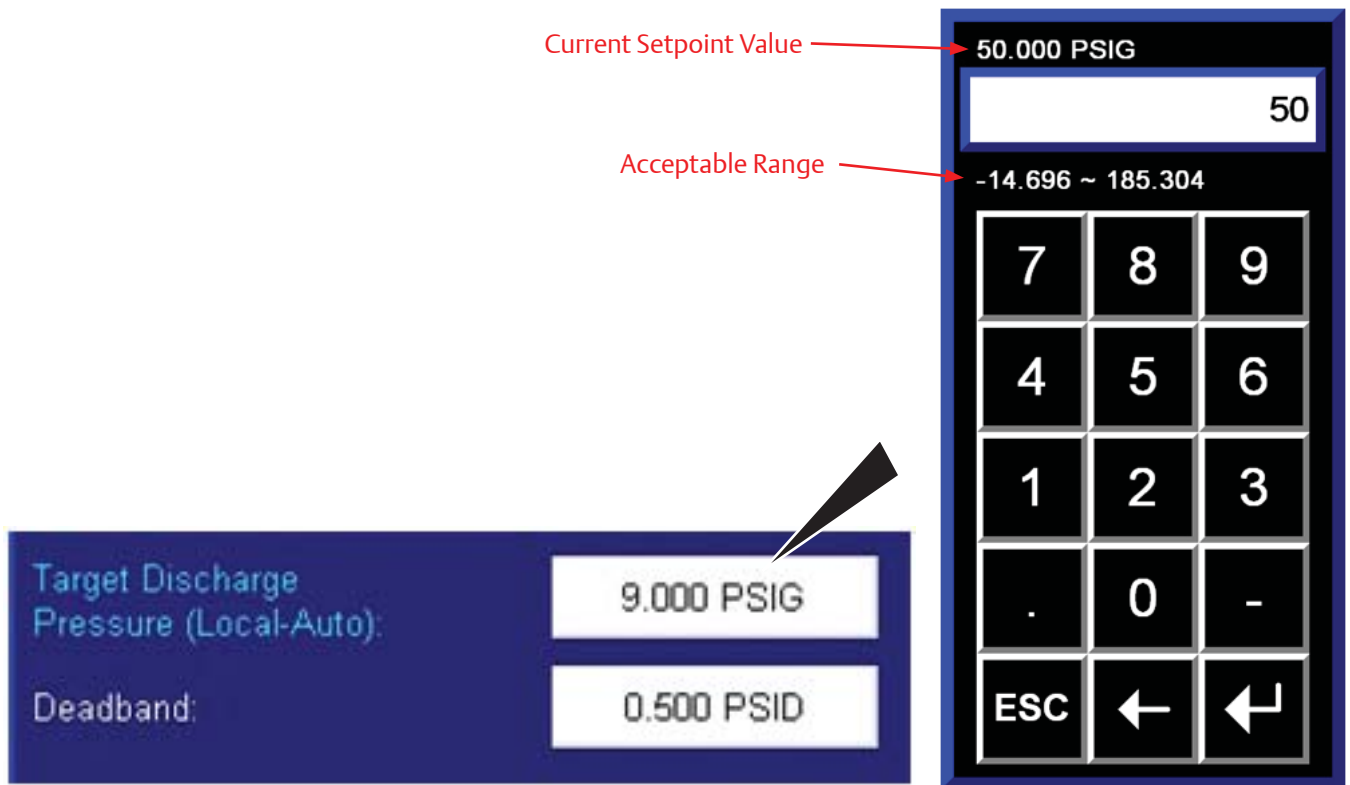

Figure 7-1. Numeric Entry Pop-up Screen

Section 7 • Blower Configuration and Control Setpoints

Blower Configuration Screen

NOTE

Screens may have inverted colors for ease of readability.

BLOWER CONFIGURATION

One of the following selections may be made for each Blower:

- Out of Service: The blower will not run if selected. Blower-Specific alarms and trips will not be generated.
- Preset Speed 1-4: The blower will run at the preset speed. The preset speeds are settable on the Blower Control Setpoints (Suction or Discharge Pressure) screen.
- PID Speed Control: The blower will run at the speed commanded from the Suction Pressure or Discharge Pressure control PID algorithm. If multiple blowers are run in PID Speed Control, they will all run at the same speed.

CONTROL MODE

- Target Suction Pressure: This is the desired suction pressure the blower will try to maintain.
- Upper and Lower Deadband: This is a range of pressures above and below the Target Suction Pressure. Within this range, no capacity slide position adjustments will be made.
- Upper and Lower Proportional Band: This is a range of pressures above and below the Target Suction Pressure. Within this range, the controller will make proportionally smaller adjustments to capacity slide position.

SUCTION/DISCHARGE PRESSURE SOURCE

The suction and discharge pressure source determines which instrument will be used to control the blower speed PID algorithm and load limits. A valid pressure source must be selected for both suction and discharge pressure.

LFG Blower Skid: Blower Configuration - Authorized Users ONLY

The screenshot displays the Blower Configuration interface for four blowers. Each blower unit (BLOWER 1, 2, 3, and 4) shows its status (STOPPED or OUT OF SERVICE), a blower icon, and a list of preset speeds (50%, 55%, 70%, 80%) and PID Speed Control. Runtime (HH:MM) is shown for each. The Control Mode is set to Suction Pressure. The Suction Pressure Source is set to Suction Header, and the Discharge Pressure Source is set to Discharge Header. The Anti-Recycle Time is 20 Minutes, and the Blower Offset Dwell Time is 30 Seconds. A note states: "**This is the time delay between blower starts. Entering a '0' means that all blowers will start at the same time." Buttons for Log Out (SUPER), Valid Configuration, Blower Control (SP), and Back to Menu are visible.

Figure 7-2. Blower Configuration Screen

Section 7 • Blower Configuration and Control Setpoints

- If suction pressure control is selected, the selected suction pressure source will control the blower speed command, and the selected discharge pressure source will control load limiting and forced unloading.
- If discharge pressure control is selected, the selected discharge pressure source will control the blower speed command, and the selected suction pressure source will control load limiting and forced unloading.

ANTI-RECYCLE

After a blower motor stops, the anti-recycle function will become active. The motor will not be allowed to re-start until the anti-recycle time is up. The anti-recycle function is blower specific: one blower in anti-recycle will not affect the other blowers on the package. If the blower package is started and a blower configured to run is in anti-recycle, that blower will start once the anti-recycle timer is up.

START UP

When multiple blowers are starting up, they start sequentially and increase in order. The offset dwell time is what determines the amount of delay between starting each individual blower. The purpose of this function is to reduce the load on the electrical infrastructure when necessary. Setting this time to “0” means that all blowers configured to run will start at the same time.

In order to be able to start the blower package, the blower configuration must be valid. For the blower configuration to be valid, all of the following rules must be met:

- At least one blower must be in service (selected to run in preset speed or PID Speed Control).
- The selected suction and discharge pressure source must be valid based on the configuration of the package. (Example: to select a header pressure transducer as a control source, the header pressure transducer must be installed, to select a blower suction or discharge pressure transducer as a control source, that particular blower must be in service.

Blower Control Setpoints - Suction Pressure

The Blower Control Setpoints page 1 (Suction Pressure) screen appears when navigating to “Blower Control Setpoints” from the menu screen when Suction Pressure control is selected. Setpoints for desired suction pressure, PID Tuning, and Load Limits are accessible from this screen. For more information and operational descriptions, see section 2 “Operational Descriptions.”

SUCTION PRESSURE CONTROL

- Target Suction Pressure: This is the desired suction pressure the blower will try to maintain.
- Deadband: This is a range of pressures above and below the Target Suction Pressure. Within this range, no speed adjustments will be made.

PID TUNING

- Loop Update Time: This is the cycle time of the PID controller.
- Proportional Gain (Kp): This is the proportional constant of the PID calculation.
- Integral Gain (Ki): This is the integral constant of the PID calculation.
- Derivative Gain (Kd): This is the derivative constant of the PID calculation.

HIGH DISCHARGE PRESSURE LOAD LIMITS

- Inhibit Loading: Blower will not be allowed to increase speed if Discharge Pressure rises above this setpoint.
- Unload At: Blower will begin continuously decreasing speed if Discharge Pressure rises above this setpoint.
- Unload To: If forced unloading is active, the blower will unload continuously until Discharge Pressure reaches this setpoint.

Section 7 • Blower Configuration and Control Setpoints

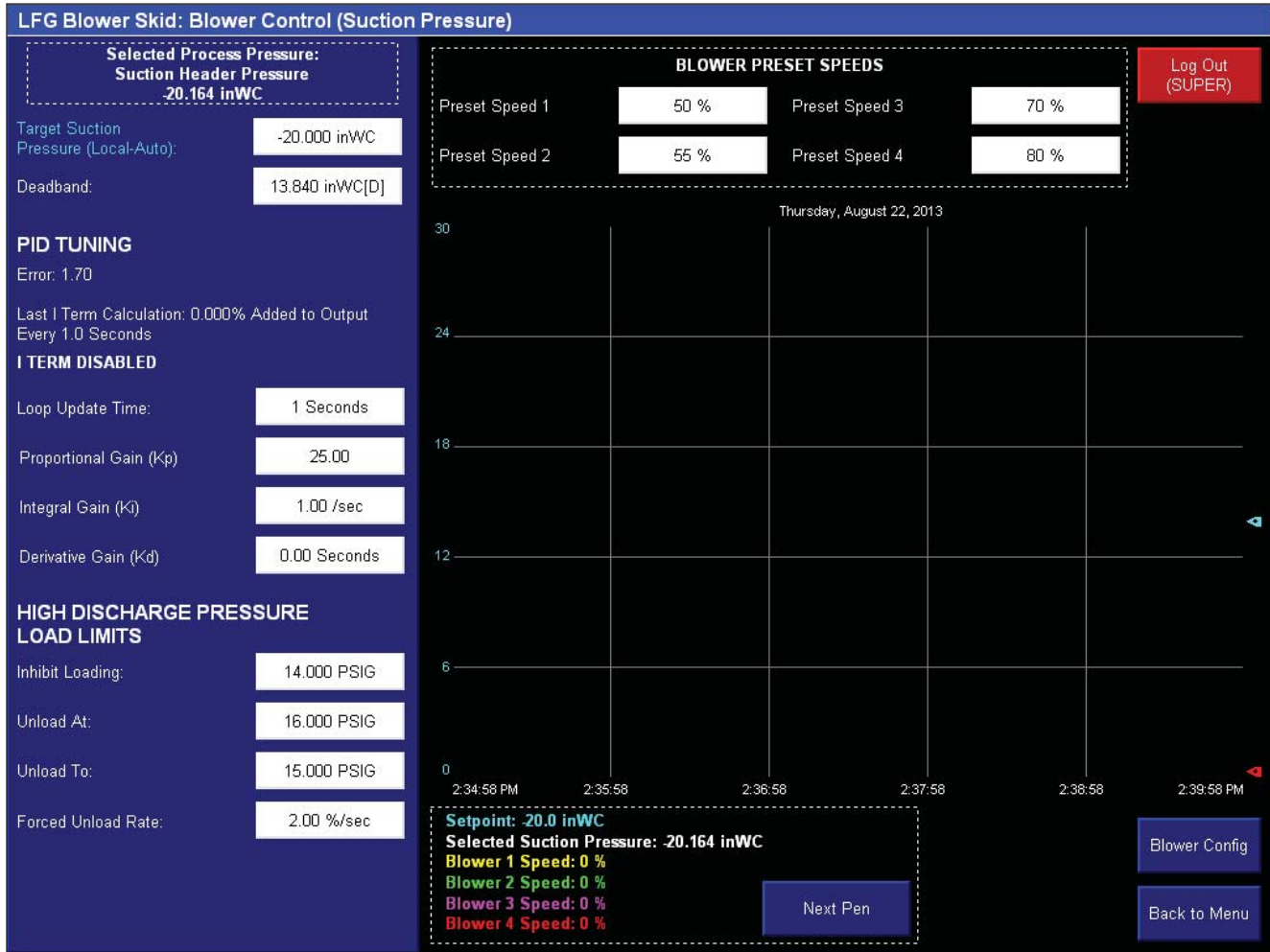

Figure 7-3. Blower Control Screen - Suction Pressure

Blower Control Setpoints - Discharge Pressure

The Blower Control Setpoints page 1 (Discharge Pressure) screen appears when navigating to “Blower Control Setpoints” from the menu screen when Discharge Pressure control is selected. Setpoints for desired discharge pressure, PID Tuning, and Load Limits are accessible from this screen. For more information and operational descriptions, see section 2 “Operational Descriptions.”

DISCHARGE PRESSURE CONTROL

- Target Discharge Pressure: This is the desired suction pressure the blower will try to maintain.
- Deadband: This is a range of pressures above and below the Target Suction Pressure. Within this range, no speed adjustments will be made.

PID TUNING

- Loop Update Time: This is the cycle time of the PID

controller.

- Proportional Gain (Kp): This is the proportional constant of the PID calculation.
- Integral Gain (Ki): This is the integral constant of the PID calculation.
- Derivative Gain (Kd): This is the derivative constant of the PID calculation.

LOW SUCTION PRESSURE LOAD LIMITS

- Inhibit Loading: Blower will not be allowed to increase speed if Suction Pressure falls below this setpoint.
- Unload At: Blower will begin continuously decreasing speed if Suction Pressure falls below this setpoint.
- Unload To: If forced unloading is active, the blower will decrease its speed continuously until Suction Pressure reaches this setpoint.

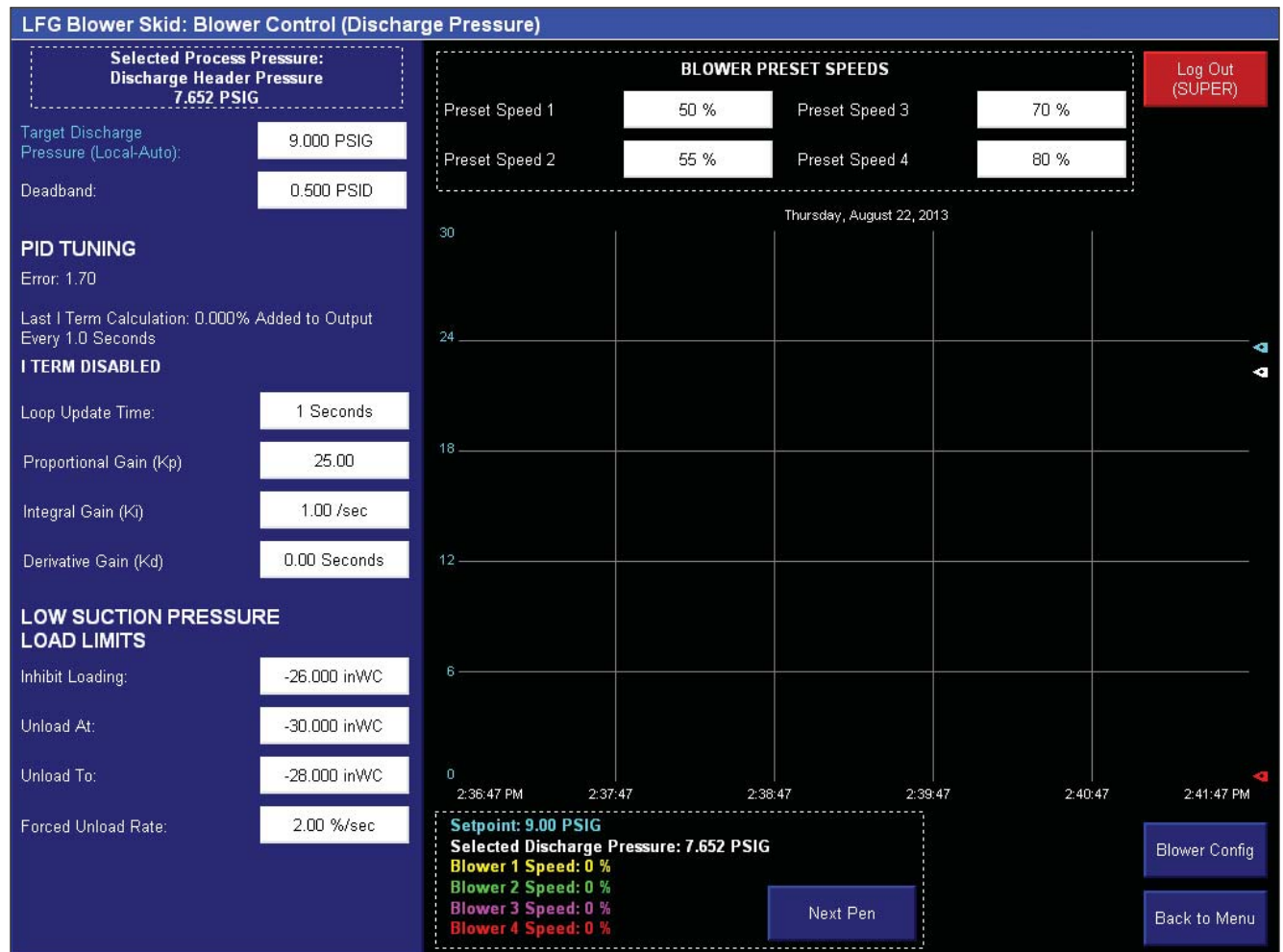

Figure 7-4. Blower Control Screen - Discharge Pressure

Alarm and Trip Setpoints

Alarm and Trip Setpoints - Page 1

NOTE

Screens may have inverted colors for ease of readability.

The blower controller continuously monitors operational and process data and annunciates an alarm and/or shuts the blower down if any condition becomes abnormal. The alarm and trip points for some of the operational and process data are adjustable by the user in the alarm and trip setpoints screens. The alarm and trip setpoints are interlocked such that a low alarm may not be set lower than a low trip, and a high trip may not be set below a high alarm.

Actual values of the specific operational and process data is shown in the column in the middle of the screen. Setpoints are only shown for applicable alarm and trip points.

- Suction Pressure: Low Alarm and Low Trip setpoints for suction pressure at the individual blower or header (if selected).
- Discharge Pressure: High Alarm and High Trip setpoints for discharge pressure at the individual blower or header (if selected).
- Discharge Temperature: High Alarm and High Trip setpoints for blower discharge temperature.
- Motor Winding Temperature: High Alarm and High Trip setpoints for temperature of the main motor windings, if motor winding RTDs are installed.
- Motor Bearing Temperature: High Alarm and High Trip setpoints for temperature of the main motor bearings, if motor bearing RTDs are installed.

LFG Blower Skid: Alarm and Trip Setpoints - 1 of 2						
	Low Trip	Low Alarm	Actual	High Alarm	High Trip	Log Out (SUPER)
Suction Pressure	-40.000 inWC	-35.000 inWC	BL1: -24.0 inWC BL2: -23.3 inWC BL3: -22.9 inWC BL4: -22.5 inWC			
Discharge Pressure			BL1: 7.79 PSIG BL2: 7.82 PSIG BL3: 7.83 PSIG BL4: 7.85 PSIG	17.000 PSIG	20.000 PSIG	
Discharge Temperature			BL1: 161.0 °F BL2: 161.0 °F BL3: 161.0 °F BL4: 161.0 °F	255.0 °F	260.0 °F	
Motor Winding Temperature			BL1 φA: 140.1 °F BL1 φB: 140.2 °F BL1 φC: 140.3 °F BL2 φA: 141.1 °F BL2 φB: 142.1 °F BL2 φC: 143.1 °F BL3 φA: 142.1 °F BL3 φB: 142.2 °F BL3 φC: 142.3 °F BL4 φA: 143.1 °F BL4 φB: 143.2 °F BL4 φC: 143.3 °F	260.0 °F	270.0 °F	
Motor Bearing Temperature			BL1 ODE: 90.1 °F BL1 DE: 90.2 °F BL2 ODE: 91.1 °F BL2 DE: 91.2 °F BL3 ODE: 92.1 °F BL3 DE: 92.2 °F BL4 ODE: 93.1 °F BL4 DE: 93.2 °F	170.0 °F	180.0 °F	NEXT
						Back to Menu

Figure 8-1. Alarm and Trip Setpoints Screen - 1 of 2

Section 8 • Alarm and Trip Setpoints

Alarm and Trip Setpoints - Page 2

- Motor Amps: High Alarm and High Trip setpoints for blower motor amps.
- Inlet Scrubber Pressure Drop: High alarm setpoint for pressure drop across the inlet scrubber.
- Outlet Scrubber Pressure Drop: High alarm setpoint for pressure drop across the outlet scrubber.
- Main Motor FLA: Convenience calculation for motor amp limits.

LFG Blower Skid: Alarm and Trip Setpoints - 2 of 2						
	Low Trip	Low Alarm	Actual	High Alarm	High Trip	Log Out (SUPER)
Motor Amps			BL1: 0.0 Amps BL2: 0.0 Amps BL3: 0.0 Amps BL4: 0.0 Amps	125.0 Amps	130.0 Amps	
Inlet Scrubber Pressure Drop			0.00 PSID	2.000 PSID		
Outlet Scrubber Pressure Drop			1.00 PSID	2.000 PSID		
						BACK
			Main Motor FLA	107% = 111.3 Amps 115% = 119.6 Amps 120% = 124.8 Amps 125% = 130.0 Amps		Back to Menu
				104.0 Amps		

Figure 8-2. Alarm and Trip Setpoints Screen - 2 of 2

Aftercooler Screens

AFTERCOOLER (VFD TYPE) SETPOINTS

- Start Aftercooler Above: Defines the temperature the aftercooler fans will come on at minimum speed.
- Target Aftercooler Outlet Temperature: Defines the desired temperature of gas at the outlet of the aftercooler. The aftercooler fan speed will adjust to maintain this temperature.
- Deadband: Range above and below setpoint where the controller will not make adjustments to fan speed.
- PID Tuning: PID Calculations displayed to aid in tuning the PID loop.
- Loop Update Time: Defines the PID controller loop time. The PID calculation will update every cycle of the loop update timer.
- Proportional Gain (Kp): Defines the Proportional Constant of the PID calculation.
- Integral Gain (Ki): Defines the Integral Constant of the PID calculation.
- Derivative Gain (Kd): Defines the Derivative Constant of the PID Calculation.
- Minimum Speed: Defines the minimum aftercooler fan speed.
- Aftercooler VFD Force: Allows the user to manually force the aftercooler fan(s) to a settable speed. Activating the Aftercooler VFD Force pushbutton will command the aftercooler fan(s) to go to the set speed, and will override calculations from the PID Controller.



Figure 9-1. Aftercooler (VFD Type) Screen

Section 9 • Step and PID Device Control Screens

AFTERCOOLER (STEP TYPE) SETPOINTS

- Start Aftercooler Above: Defines the temperature the first aftercooler step will come on.
- Target Aftercooler Outlet Temperature: Defines the desired temperature of gas at the outlet of the aftercooler. The controller will cycle fans on and off to maintain this temperature.
- Deadband: Range above and below setpoint where the controller will not add or remove any steps.
- Step Dwell Time: Amount of time Aftercooler Outlet Temperature must be outside the deadband to add or remove a step.
- Aftercooler Fan Configuration: Truth table that defines which fan outputs are turned on in each step.

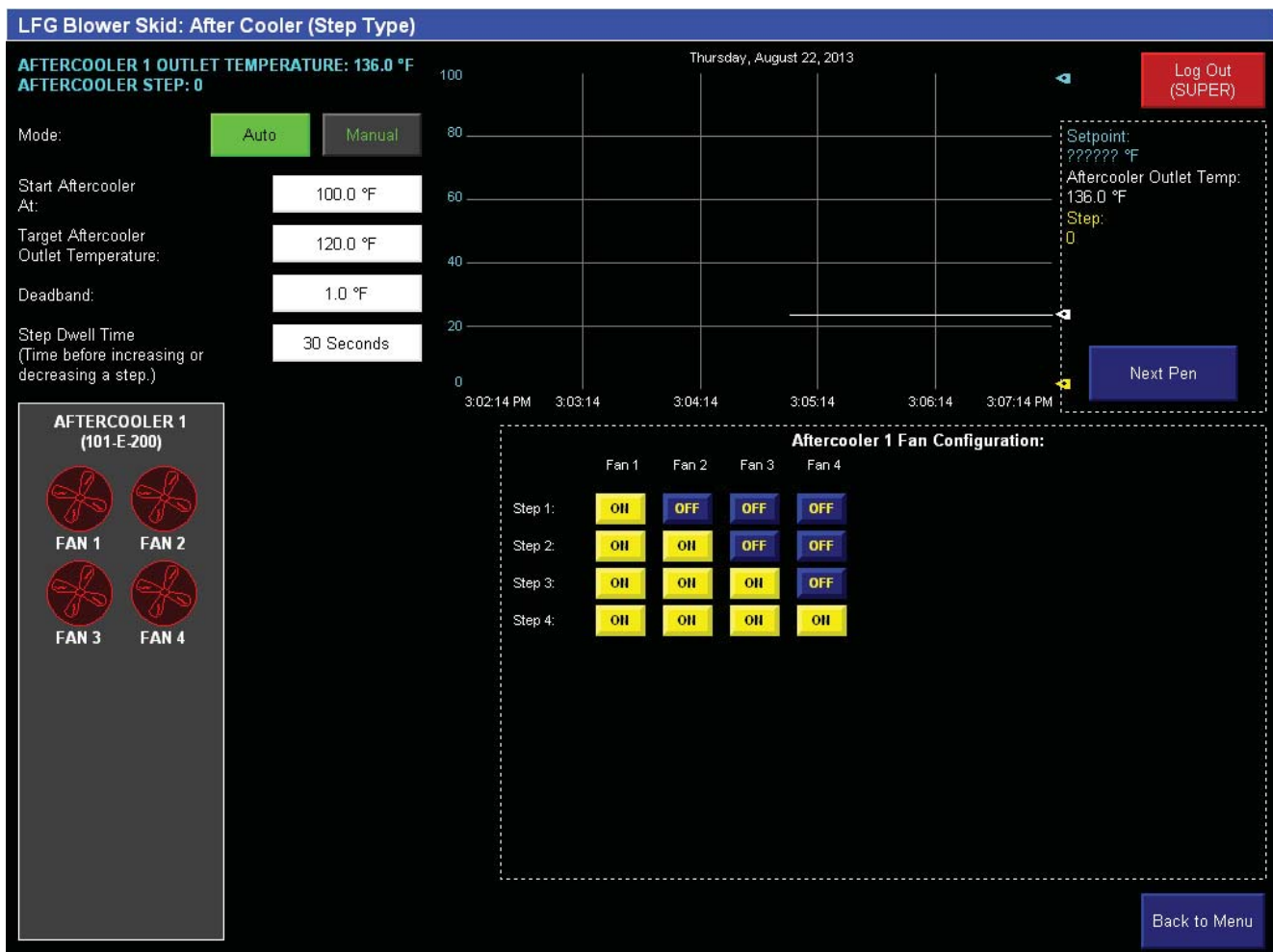

Figure 9-2. Aftercooler (Step Type) Screen

Section 9 • Step and PID Device Control Screens

WATER COOLED AFTERCOOLER SETPOINTS

- Open Valve Above: Defines the temperature the aftercooler water supply valve will open to minimum position.
- Target Aftercooler Outlet Temperature: Defines the desired temperature of gas at the outlet of the aftercooler. The aftercooler water supply valve position will adjust to maintain this temperature.
- Deadband: Range above and below setpoint where the controller will not make adjustments to water supply valve position.
- PID Tuning: PID Calculations displayed to aid in tuning the PID loop.
- Loop Update Time: Defines the PID controller loop time. The PID calculation will update every cycle of the loop update timer.
- Proportional Gain (Kp): Defines the Proportional Constant of the PID calculation.
- Integral Gain (Ki): Defines the Integral Constant of the PID calculation.
- Derivative Gain (Kd): Defines the Derivative Constant of the PID Calculation.
- Minimum Valve Open: Defines the minimum water supply valve position.
- Aftercooler Valve Force: Allows the user to manually force the aftercooler water supply valve to a settable position. Activating the Aftercooler Valve Force pushbutton will command the aftercooler water supply valve to go to the set position, and will override calculations from the PID Controller.



Figure 9-3. Water Cooled Aftercooler Screen

Discharge Recycle Valve Screen

DISCHARGE RECYCLE VALVE SETPOINTS

- Target Recycle Control Pressure: Defines the pressure at which the discharge recycle valve will begin to open.
- Deadband: Range above and below setpoint where the controller will not make adjustments to the recycle valve position.
- PID Tuning: PID Calculations displayed to aid in tuning the PID loop.
- Loop Update Time: Defines the PID controller loop time. The PID calculation will update every cycle of the loop update timer.
- Proportional Gain (Kp): Defines the Proportional Constant of the PID calculation.
- Discharge Recycle Valve Force: Allows the user to manually force the discharge recycle valve to a settable position. Activating the Discharge Recycle Valve Force pushbutton will command the discharge recycle valve to go to the set position, and will override calculations from the PID Controller.

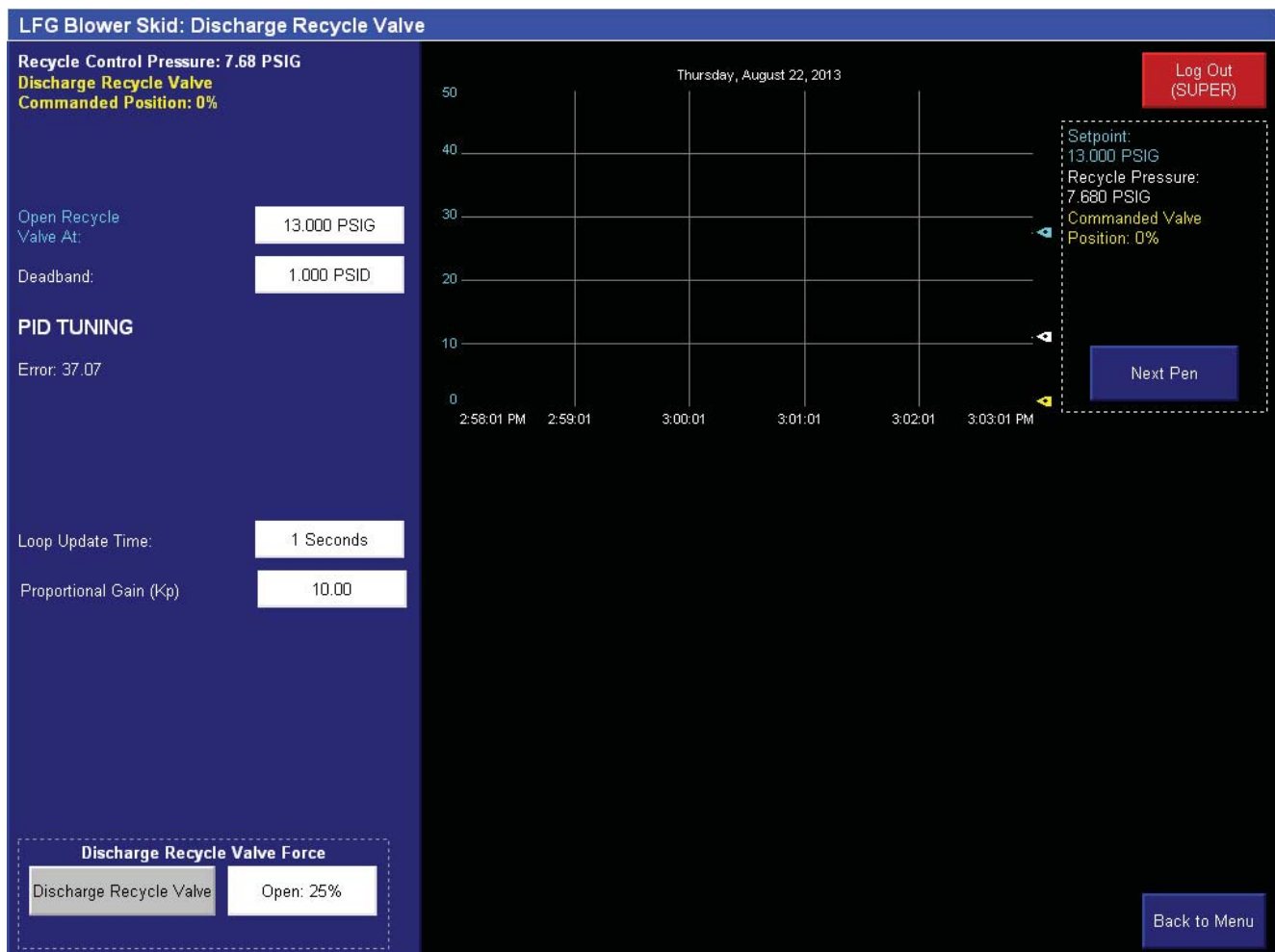

Figure 9-4. Discharge Recycle Valve Screen

Start Menu Popup Screen

Pressing “Start Menu” on the blower overview screen will open the “Start Menu” popup screen. The “Start Menu” screen allows the user to change operating modes and start the blower package.

- Remote: Pressing the remote pushbutton puts the blower control in remote mode. The remote mode pushbutton will only be visible if the configuration is correct
- Local: Pressing the Local pushbutton puts the blower control in local mode.

- Auto: Pressing the Auto pushbutton puts the blower control in Auto mode.
- Manual: Pressing the Manual pushbutton puts the blower control in Manual mode.
- Unit Start: Pressing the Unit Start pushbutton initiates a blower start.

For more information on operating modes, see the section on Operational Descriptions.

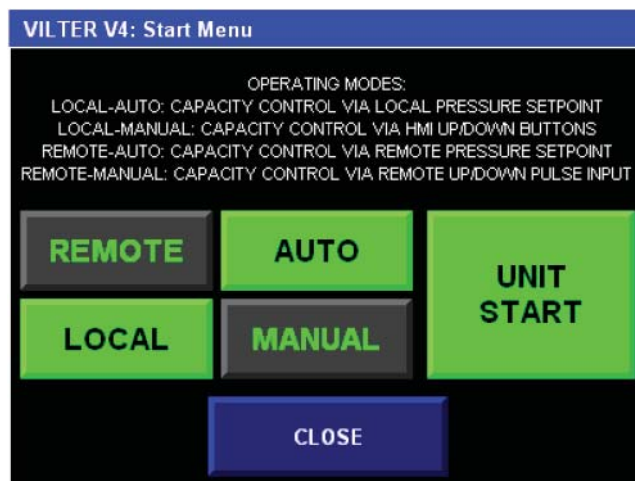

Figure 9-5. Start Menu Popup Screen

Section 10 • Diagnostic Screens

IO/Comms Diagnostics Screen

COMMS DIAGNOSTICS AND I/O STATUS

NOTE

Some screens may have inverted colors for ease of readability.

The IO/Comms Diagnostics Screen is divided into 3 sections.

- **SYSTEM INFORMATION**
 - Shows basic information about the Blower PLC panel: Vilter sales order number, Software revision, IP addresses, hardware information, and firmware revisions of blower PLC and HMI.
- **BITS/REALS FROM DCS:**
 - Shows commands from a central controller or DCS to verify communications setup with a central controller or DCS.

LOCAL I/O STATUS

- Shows a graphic representation of the blower PLC's local I/O modules and the raw data specific to each channel.
- Use the following rules to interpret the data:
 - Discrete inputs and outputs: Green = ON
 - Analog Inputs and outputs (4-20mA): The number shown for a specific channel represents the signal in .001 mA. Ex: a value of 4000 indicates 4.000 mA.
 - RTD Inputs: The number shown for a specific channel represents the temperature reading in Fahrenheit times 10. Ex: a value of 730 indicates 73.0 degrees Fahrenheit.

LFG Blower Skid: Comms Diagnostics

SYSTEM INFORMATION
 Vilter Sales Order: S145928
 Vilter Software Revision: VBL 4.00

PLC Type: 1769-L33ER CompactLogix Firmware Revision: 20.0 IP: CompactLogix at 10.8.0.82	HMI Type: Panelview Plus 1500 Firmware Revision: 6.0 IP: 0.0.0.0
--	---

Last Rung Edit: 8/22/2013 14:53

Log Out (SUPER)

BITS IN FROM DCS		REALS IN FROM DCS	
Blower 1 Remote Enable	0	Remote Discharge Pressure Setpoint	82.7000
Blower 2 Remote Enable	0	Remote Suction Pressure Setpoint	34.7000
Blower 3 Remote Enable	0	Common Discharge Header Pressure From DCS	74.7000
Blower 4 Remote Enable	0	Common Suction Header Pressure From DCS	64.7000
Local Mode Command From DCS	0	Blower 1 Remote Manual Speed Setpoint	22.0000
Remote Mode Command From DCS	0	Blower 2 Remote Manual Speed Setpoint	0.0000
Reset Alarms from DCS	0	Blower 3 Remote Manual Speed Setpoint	0.0000
Soft Run Command From DCS	0	Blower 4 Remote Manual Speed Setpoint	0.0000

Watchdog Status: FAULTED

LOCAL I/O STATUS

SLOT 1	SLOT 2	SLOT 3	SLOT 4	SLOT 5	SLOT 6	
DIGITAL IN	DIGITAL IN	DIGITAL IN	DIGITAL OUT	DIGITAL OUT	ANALOG IN	
0 4 8 12 1 5 9 13 2 6 10 14 3 7 11 15	0 4 8 12 1 5 9 13 2 6 10 14 3 7 11 15	0 4 8 12 1 5 9 13 2 6 10 14 3 7 11 15	0 4 8 12 1 5 9 13 2 6 10 14 3 7 11 15	0 4 8 12 1 5 9 13 2 6 10 14 3 7 11 15	Ch0: 12010 Ch1: 0 Ch2: 0 Ch3: 9000 Ch4: 8950 Ch5: 12050 Ch6: 8960 Ch7: 12060	Ch8: 8965 Ch9: 12065 Ch10: 8970 Ch11: 12070 Ch12: 0 Ch13: 12000 Ch14: 0 Ch15: 0
OK	OK	OK	OK	OK	OK	

SLOT 7	SLOT 8	SLOT 9	SLOT 10	SLOT 11	SLOT 12	SLOT 13
ANALOG IN	ANALOG OUT	RTD IN	RTD IN	RTD IN	RTD IN	RTD IN
Ch0: 4000 Ch1: 4000 Ch2: 4000 Ch3: 4000 Ch4: 0 Ch5: 0 Ch6: 0 Ch7: 0	Ch0: 4000 Ch1: 4000 Ch2: 4000 Ch3: 4000 Ch4: 0 Ch5: 0 Ch6: 0 Ch7: 0	Ch0: 881 Ch1: 1610 Ch2: 882 Ch3: 1620 Ch4: 883 Ch5: 1630	Ch0: 884 Ch1: 1640 Ch2: 0 Ch3: 1360 Ch4: 901 Ch5: 1401	Ch0: 1402 Ch1: 1403 Ch2: 902 Ch3: 911 Ch4: 1411 Ch5: 1421	Ch0: 1431 Ch1: 912 Ch2: 921 Ch3: 1421 Ch4: 1422 Ch5: 1423	Ch0: 922 Ch1: 931 Ch2: 1431 Ch3: 1432 Ch4: 1433 Ch5: 932
OK	OK	OK	OK	OK	OK	OK

VFD Diagnostics

Back to Menu

Figure 10-1. IO/Comms Diagnostics Screen

Section 10 • Diagnostic Screens

Event List Screen

The event list is a running log of alarm, trip, and status information. The event list shows the last 400 events logged by the blower PLC, most recent is at the top of the screen. Each event is logged with a time and date stamp.

To scroll through past events, use the navigation buttons at the bottom of the screen.

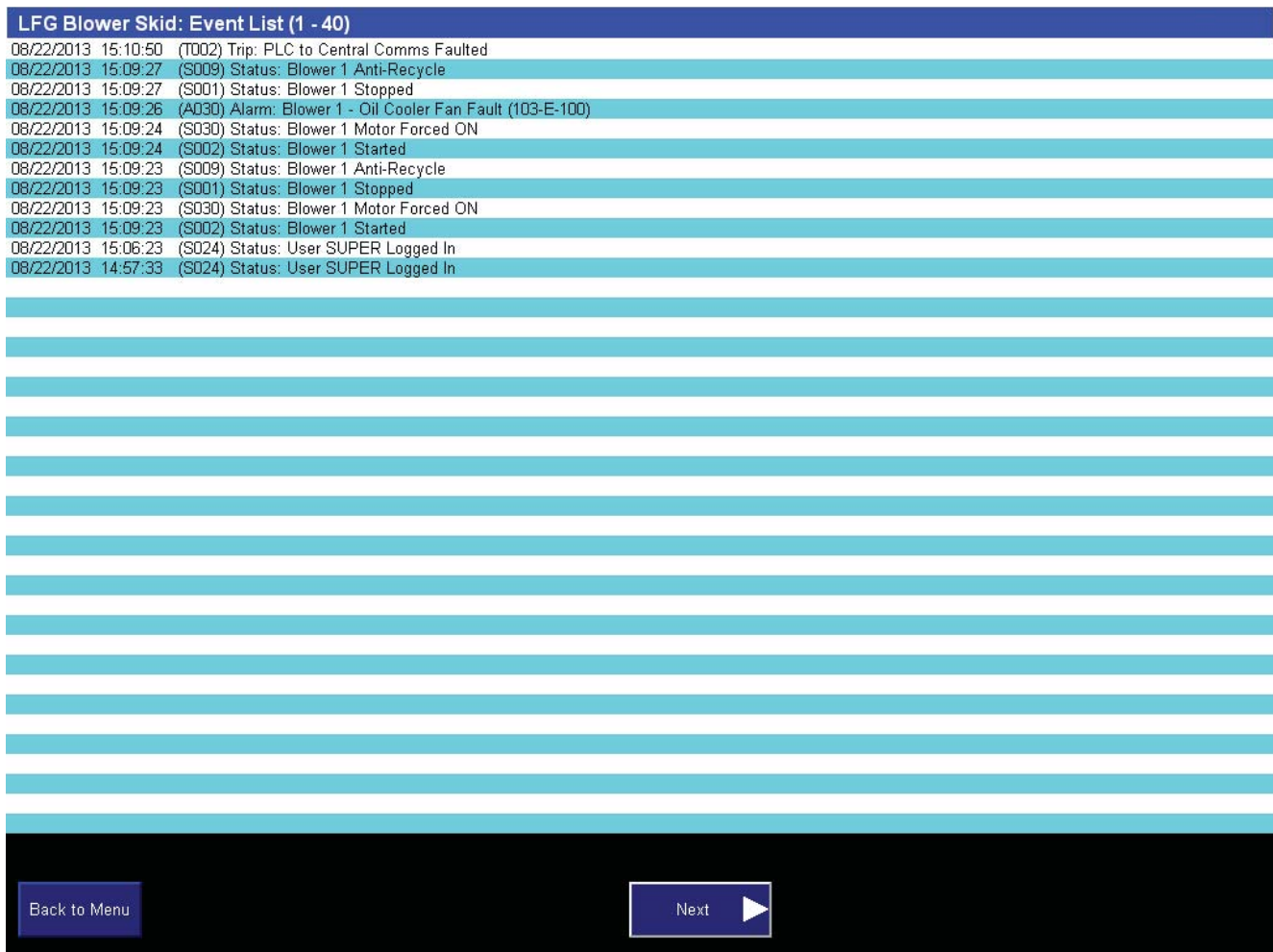

Figure 10-2. Event List Screen

Diagnostics Forced Outputs Screen

The force outputs screen allows a user logged in as “SUPER” to force discrete and analog outputs to verify operation of devices on the blower package. Outputs that are available to force depend on the configuration for a specific blower machine or package.

- Pressing a force button forces ON the PLC output for that particular device. If there is an associated analog output (speed or position command) the keyed in value will be applied to that output. Pressing the force button again removes the force.
- Pressing “Clear all Forces” removes all active forces.

LFG Blower Skid: Diagnostic Force Outputs - Authorized Users ONLY

Blower 1 Motor Force
Blower 1 Motor | Speed: 76%
*Press and Hold

Blower 2 Motor Force
Blower 2 Motor | Speed: 55%
*Press and Hold

Blower 3 Motor Force
Blower 3 Motor | Speed: 100%
*Press and Hold

Blower 4 Motor Force
Blower 4 Motor | Speed: 75%
*Press and Hold

Force Aftercooler 1 (Step Type)
1 2 3 4 5
6 7 8 9 10

Discharge Recycle Valve Force
Discharge Recycle Valve | Open: 25%

Alarm Indication Force
Alarm Indication

Trip Indication Force
Trip Indication

SUPPLEMENTAL SHUTDOWN OUTPUT FORCE - Blower 1
Supplemental Shutdown (Hold 3 Seconds)
WARNING: Forcing The Supplemental Shutdown Output ON will trigger Emergency Stop and may remove PLC Panel Power.

SUPPLEMENTAL SHUTDOWN OUTPUT FORCE - Blower 2
Supplemental Shutdown (Hold 3 Seconds)
WARNING: Forcing The Supplemental Shutdown Output ON will trigger Emergency Stop and may remove PLC Panel Power.

SUPPLEMENTAL SHUTDOWN OUTPUT FORCE - Blower 3
Supplemental Shutdown (Hold 3 Seconds)
WARNING: Forcing The Supplemental Shutdown Output ON will trigger Emergency Stop and may remove PLC Panel Power.

SUPPLEMENTAL SHUTDOWN OUTPUT FORCE - Blower 4
Supplemental Shutdown (Hold 3 Seconds)
WARNING: Forcing The Supplemental Shutdown Output ON will trigger Emergency Stop and may remove PLC Panel Power.

Log Out (SUPER)

CLEAR ALL FORCES
Clear All Forces

NEXT
Back to Menu

Figure 10-3. Diagnostics Forced Output Screen

Section 10 • Diagnostic Screens

Captured Data at Shutdown Screen

The captured data at shutdown screen shows process and operational data at the time the blower shuts down. Data from the last 5 shutdowns are logged. Each shutdown is given a time and date stamp. The most recent shutdown is on the left.

LFG Blower Skid: Captured Data at Shutdown (1 of 2)		09-06-2013 16:18:13	09-06-2013 15:45:39	09-06-2013 15:21:51	09-05-2013 13:45:33	09-05-2013 10:18:59
101-PT-003	Suction Header Pressure	-4.699 inWC	-4.699 inWC	-4.699 inWC	-4.699 inWC	-4.699 inWC
131-PT-006	Discharge Header Pressure	11.842 PSIG	11.842 PSIG	10.445 PSIG	10.445 PSIG	7.652 PSIG
101-TE-200	Aftercooler 1 Outlet Temperature	125.0 °F	125.0 °F	125.0 °F	125.0 °F	51.7 °C
111-PT-300	Discharge Recycle Control Pressure	12.122 PSIG	12.122 PSIG	10.460 PSIG	7.708 PSIG	7.708 PSIG
	Discharge Recycle Valve	4 %	4 %	0 %	0 %	0 %
101-TE-010	Blower 1 Suction Temperature	73.1 °F	73.1 °F	73.1 °F	73.1 °F	22.8 °C
101-TE-012	Blower 1 Discharge Temperature	212.1 °F	212.1 °F	212.1 °F	212.1 °F	100.1 °C
101-PT-004	Blower 1 Suction Pressure	-5.473 inWC	-5.473 inWC	-5.473 inWC	-5.473 inWC	-5.473 inWC
101-PT-005	Blower 1 Discharge Pressure	11.870 PSIG	11.870 PSIG	7.680 PSIG	7.680 PSIG	7.680 PSIG
101-D-100	Blower 1 Commanded Speed	0 %	70 %	70 %	70 %	70 %
VFD-003D	Blower 1 Actual Speed	0 %	44 %	44 %	44 %	44 %
VFD-003D	Blower 1 Motor Amps	0 AMPS	44 AMPS	44 AMPS	44 AMPS	44 AMPS
107-TE-002	Blower 1 Phase A Temperature	120.1 °F	120.1 °F	120.1 °F	120.1 °F	48.9 °C
107-TE-003	Blower 1 Phase B Temperature	120.2 °F	120.2 °F	120.2 °F	120.2 °F	49.0 °C
107-TE-004	Blower 1 Phase C Temperature	120.3 °F	120.3 °F	120.3 °F	120.3 °F	49.1 °C
107-TE-001	Blower 1 ODE Bearing Temperature	90.1 °F	90.1 °F	90.1 °F	90.1 °F	32.3 °C
107-TE-005	Blower 1 DE Bearing Temperature	90.2 °F	90.2 °F	90.2 °F	90.2 °F	32.3 °C
111-TE-010	Blower 2 Suction Temperature	73.2 °F	73.2 °F	73.2 °F	73.2 °F	22.9 °C
111-TE-12	Blower 2 Discharge Temperature	212.2 °F	212.2 °F	212.2 °F	212.2 °F	100.1 °C
111-PT-004	Blower 2 Suction Pressure	-5.395 inWC	-5.395 inWC	-5.395 inWC	-5.395 inWC	-5.395 inWC
111-PT-005	Blower 2 Discharge Pressure	11.873 PSIG	11.873 PSIG	7.683 PSIG	7.683 PSIG	7.683 PSIG
111-D-100	Blower 2 Commanded Speed	75 %	75 %	75 %	75 %	75 %
VFD-003C	Blower 2 Actual Speed	50 %	50 %	50 %	50 %	50 %
VFD-003C	Blower 2 Motor Amps	50 AMPS	50 AMPS	50 AMPS	50 AMPS	50 AMPS
117-TE-002	Blower 2 Phase A Temperature	121.1 °F	121.1 °F	121.1 °F	121.1 °F	49.5 °C
117-TE-003	Blower 2 Phase B Temperature	121.2 °F	121.2 °F	121.2 °F	121.2 °F	49.6 °C
117-TE-004	Blower 2 Phase C Temperature	121.3 °F	121.3 °F	121.3 °F	121.3 °F	49.6 °C
117-TE-001	Blower 2 ODE Bearing Temperature	91.1 °F	91.1 °F	91.1 °F	91.1 °F	32.8 °C
117-TE-005	Blower 2 DE Bearing Temperature	91.2 °F	91.2 °F	91.2 °F	91.2 °F	32.9 °C

Figure 10-4. Captured Data at Shutdown Screen

Section 10 • Diagnostic Screens

Initial Baseline Running Data Screen

The Initial Baseline Running Data screen shows data collected when the blower is first started up. Vilter Service Technicians or Engineers only may log this data. This is to give a reference point for comparing operational and process data to a baseline set of data collected when the blower package was new.

LFG Blower Skid: Initial Baseline Running Data (1 of 2)						
		09-06-2013 15:11:58	09-06-2013 15:10:58	09-06-2013 15:09:58	09-06-2013 15:08:58	09-06-2013 15:07:57
101-PT-003	Suction Header Pressure	-4.699 inWC	-4.699 inWC	-4.699 inWC	-4.699 inWC	-4.699 inWC
131-PT-006	Discharge Header Pressure	10.445 PSIG	10.445 PSIG	10.445 PSIG	10.445 PSIG	10.445 PSIG
101-TE-200	Aftercooler 1 Outlet Temperature	125.0 °F	125.0 °F	125.0 °F	125.0 °F	125.0 °F
111-PT-300	Discharge Recycle Control Pressure	10.460 PSIG	10.460 PSIG	10.460 PSIG	10.460 PSIG	10.460 PSIG
	Discharge Recycle Valve	0 %	0 %	0 %	0 %	0 %
101-TE-010	Blower 1 Suction Temperature	73.1 °F	73.1 °F	73.1 °F	73.1 °F	73.1 °F
101-TE-012	Blower 1 Discharge Temperature	212.1 °F	212.1 °F	212.1 °F	212.1 °F	212.1 °F
101-PT-004	Blower 1 Suction Pressure	-5.473 inWC	-5.473 inWC	-5.473 inWC	-5.473 inWC	-5.473 inWC
101-PT-005	Blower 1 Discharge Pressure	7.680 PSIG	7.680 PSIG	7.680 PSIG	7.680 PSIG	7.680 PSIG
TE-113	Blower 1 Commanded Speed	70 %	70 %	70 %	70 %	70 %
VFD-003D	Blower 1 Actual Speed	44 %	44 %	44 %	44 %	44 %
VFD-003D	Blower 1 Motor Amps	44 AMPS	44 AMPS	44 AMPS	44 AMPS	44 AMPS
107-TE-002	Blower 1 Phase A Temperature	120.1 °F	120.1 °F	120.1 °F	120.1 °F	120.1 °F
107-TE-003	Blower 1 Phase B Temperature	120.2 °F	120.2 °F	120.2 °F	120.2 °F	120.2 °F
107-TE-004	Blower 1 Phase C Temperature	120.3 °F	120.3 °F	120.3 °F	120.3 °F	120.3 °F
107-TE-001	Blower 1 ODE Bearing Temperature	90.1 °F	90.1 °F	90.1 °F	90.1 °F	90.1 °F
107-TE-005	Blower 1 DE Bearing Temperature	90.2 °F	90.2 °F	90.2 °F	90.2 °F	90.2 °F
111-TE-010	Blower 2 Suction Temperature	73.2 °F	73.2 °F	73.2 °F	73.2 °F	73.2 °F
111-TE-12	Blower 2 Discharge Temperature	212.2 °F	212.2 °F	212.2 °F	212.2 °F	212.2 °F
111-PT-004	Blower 2 Suction Pressure	-5.395 inWC	-5.395 inWC	-5.395 inWC	-5.395 inWC	-5.395 inWC
111-PT-005	Blower 2 Discharge Pressure	7.683 PSIG	7.683 PSIG	7.683 PSIG	7.683 PSIG	7.683 PSIG
	Blower 2 Commanded Speed	75 %	75 %	75 %	75 %	75 %
VFD-003C	Blower 2 Actual Speed	50 %	50 %	50 %	50 %	50 %
VFD-003C	Blower 2 Motor Amps	50 AMPS	50 AMPS	50 AMPS	50 AMPS	50 AMPS
117-TE-002	Blower 2 Phase A Temperature	121.1 °F	121.1 °F	121.1 °F	121.1 °F	121.1 °F
117-TE-003	Blower 2 Phase B Temperature	121.2 °F	121.2 °F	121.2 °F	121.2 °F	121.2 °F
117-TE-004	Blower 2 Phase C Temperature	121.3 °F	121.3 °F	121.3 °F	121.3 °F	121.3 °F
117-TE-001	Blower 2 ODE Bearing Temperature	91.1 °F	91.1 °F	91.1 °F	91.1 °F	91.1 °F
117-TE-005	Blower 2 DE Bearing Temperature	91.2 °F	91.2 °F	91.2 °F	91.2 °F	91.2 °F

Figure 10-5. Initial Baseline Running Data Screen

Alarms & Trips

Process and Operational data of the blower unit is continuously monitored by the blower PLC. If an abnormal condition is detected, an alarm or trip will be annunciated.

- Alarms
 - Warns of an abnormal condition. Blower may continue to run.
- Trips
 - Blower will shut down if active.

A scrolling display at the top of the overview and menu screens shows all active alarms and trips, see Figure 11-1.

Trips are shown in the red banner, alarms are shown in the yellow banner.

When a new alarm or trip is triggered, the alarm popup screen will appear showing the most recent alarm or trip, see Figure 11-2.



Figure 11-1. Alarm/Trip/Status Bars (Main Menu Screen)



Figure 11-2. Alarm/Trip Popup Screen

Section 11 • Alarms, Trips, Status Information & Troubleshooting

Alarm Listing

The following table shows all possible alarms and trips and possible causes. Some alarms and trips are application specific, and do not apply unless a specific option is selected.

To reset alarms or trips press the “Alarm Reset” Button on the overview screen. If the condition is cleared, the alarm will reset. If the condition is not cleared, the alarm will remain active.

Table 11-1. Alarm Listing

Alarm Message	Cause(s)	Notes
(A001) Alarm:		
(A002) Alarm: PLC to Central Comms Faulted	Loss of Communication with DCS/ Central - Settable Communications Watchdog Timer Expired. (Alarm and Revert to Local Selected on Communication Failure.)	Watchdog Active if Control by Communications is selected
(A003) Alarm: Blower 1 VFD Comms Faulted	Loss of Communication with Blower 1 VFD.	
(A004) Alarm: Blower 2 VFD Comms Faulted	Loss of Communication with Blower 2 VFD.	
(A005) Alarm: Blower 3 VFD Comms Faulted	Loss of Communication with Blower 3 VFD.	
(A006) Alarm: Blower 4 VFD Comms Faulted	Loss of Communication with Blower 4 VFD.	
(A007) Alarm:		
(A008) Alarm:		
(A009) Alarm:		
(A010) Alarm: Low Suction Header Pressure	Suction Header Pressure drops below "Suction Pressure" Low Alarm Setpoint	Active if monitoring Suction Header Pressure
(A011) Alarm: High Discharge Header Pressure	Suction Header Pressure rises above "Discharge Pressure" High Alarm Setpoint	Active if monitoring Discharge Header Pressure
(A012) Alarm: Aftercooler VFD Fault	Fault contact open on Aftercooler VFD	If controlling a VFD type aftercooler
(A013) Alarm: Aftercooler Fan Starter Fault	Aftercooler Fan is commanded to run, running confirmation not received.	If controlling a step-type aftercooler
(A014) Alarm:		
(A015) Alarm: User Defined Alarm 1	User defined Alarm 1	Message Defined in "Device Names" Screens
(A016) Alarm: User Defined Alarm 2	User defined Alarm 2	Message Defined in "Device Names" Screens
(A017) Alarm: User Defined Alarm 3	User defined Alarm 3	Message Defined in "Device Names" Screens
(A018) Alarm: User Defined Alarm 4	User defined Alarm 4	Message Defined in "Device Names" Screens
(A019) Alarm: User Defined Alarm 5	User defined Alarm 5	Message Defined in "Device Names" Screens

Section 11 • Alarms, Trips, Status Information & Troubleshooting

Alarm Message	Cause(s)	Notes
(A020) Alarm: Blower 1 - High Discharge Temperature	Blower 1 Discharge Temperature exceeds "Discharge Temperature" High Alarm Setpoint	
(A021) Alarm: Blower 1 - High Discharge Pressure	Blower 1 Discharge Pressure exceeds "Discharge Pressure" High Alarm Setpoint	
(A022) Alarm: Blower 1 - Low Suction Pressure	Blower 1 Suction Pressure falls below "Suction Pressure" Low Alarm Setpoint	
(A023) Alarm: Blower 1 - High Phase A Temperature	Phase A Motor Winding Temperature exceeds Motor Winding Temperature High Alarm Setpoint	Active if Displaying Motor Winding Temperatures
(A024) Alarm: Blower 1 - High Phase B Temperature	Phase B Motor Winding Temperature exceeds Motor Winding Temperature High Alarm Setpoint	Active if Displaying Motor Winding Temperatures
(A025) Alarm: Blower 1 - High Phase C Temperature	Phase C Motor Winding Temperature exceeds Motor Winding Temperature High Alarm Setpoint	Active if Displaying Motor Winding Temperatures
(A026) Alarm: Blower 1 - High ODE Bearing Temperature	Drive End Motor Bearing Temperature exceeds Motor Bearing Temperature High Alarm Setpoint	Active if Displaying Motor Bearing Temperatures
(A027) Alarm: Blower 1 - High DE Bearing Temperature	Opposite Drive End Motor Bearing Temperature exceeds Motor Bearing Temperature High Alarm Setpoint	Active if Displaying Motor Bearing Temperatures
(A028) Alarm: Blower 1 - High Motor Amps	Blower 1 Motor Amps exceeds "Motor Amps" High Alarm Setpoint	
(A029) Alarm: Blower 1 - VFD Speed Reference Fault	Blower 1 Actual Speed is not within 1% of commanded speed.	
(A030) Alarm: Blower 1 - Oil Cooler Fan Fault	Blower 1 Oil Cooler Fan is commanded to run, running confirmation is not received.	Active if an air-cooled oil cooler is installed.
(A031) Alarm:		
(A032) Alarm:		
(A033) Alarm:		
(A034) Alarm:		
(A035) Alarm:		
(A036) Alarm:		
(A037) Alarm:		
(A038) Alarm:		
(A039) Alarm:		
(A040) Alarm: Blower 2 - High Discharge Temperature	Blower 2 Discharge Temperature exceeds "Discharge Temperature" High Alarm Setpoint	
(A041) Alarm: Blower 2 - High Discharge Pressure	Blower 2 Discharge Pressure exceeds "Discharge Pressure" High Alarm Setpoint	

Section 11 • Alarms, Trips, Status Information & Troubleshooting

Alarm Message	Cause(s)	Notes
(A042) Alarm: Blower 2 - Low Suction Pressure	Blower 2 Suction Pressure falls below "Suction Pressure" Low Alarm Setpoint	
(A043) Alarm: Blower 2 - High Phase A Temperature	Phase A Motor Winding Temperature exceeds Motor Winding Temperature High Alarm Setpoint	Active if Displaying Motor Winding Temperatures
(A044) Alarm: Blower 2 - High Phase B Temperature	Phase B Motor Winding Temperature exceeds Motor Winding Temperature High Alarm Setpoint	Active if Displaying Motor Winding Temperatures
(A045) Alarm: Blower 2 - High Phase C Temperature	Phase C Motor Winding Temperature exceeds Motor Winding Temperature High Alarm Setpoint	Active if Displaying Motor Winding Temperatures
(A046) Alarm: Blower 2 - High ODE Bearing Temperature	Drive End Motor Bearing Temperature exceeds Motor Bearing Temperature High Alarm Setpoint	Active if Displaying Motor Bearing Temperatures
(A047) Alarm: Blower 2 - High DE Bearing Temperature	Opposite Drive End Motor Bearing Temperature exceeds Motor Bearing Temperature High Alarm Setpoint	Active if Displaying Motor Bearing Temperatures
(A048) Alarm: Blower 2 - High Motor Amps	Blower 2 Motor Amps exceeds "Motor Amps" High Alarm Setpoint	
(A049) Alarm: Blower 2 - VFD Speed Reference Fault	Blower 2 Actual Speed is not within 1% of commanded speed.	
(A050) Alarm: Blower 2 - Oil Cooler Fan Fault	Blower 2 Oil Cooler Fan is commanded to run, running confirmation is not received.	Active if an air-cooled oil cooler is installed.
(A051) Alarm:		
(A052) Alarm:		
(A053) Alarm:		
(A054) Alarm:		
(A055) Alarm:		
(A056) Alarm:		
(A057) Alarm:		
(A058) Alarm:		
(A059) Alarm:		
(A060) Alarm: Blower 3 - High Discharge Temperature	Blower 3 Discharge Temperature exceeds "Discharge Temperature" High Alarm Setpoint	
(A061) Alarm: Blower 3 - High Discharge Pressure	Blower 3 Discharge Pressure exceeds "Discharge Pressure" High Alarm Setpoint	
(A062) Alarm: Blower 3 - Low Suction Pressure	Blower 3 Suction Pressure falls below "Suction Pressure" Low Alarm Setpoint	

Section 11 • Alarms, Trips, Status Information & Troubleshooting

Alarm Message	Cause(s)	Notes
(A063) Alarm: Blower 3 - High Phase A Temperature	Phase A Motor Winding Temperature exceeds Motor Winding Temperature High Alarm Setpoint	Active if Displaying Motor Winding Temperatures
(A064) Alarm: Blower 3 - High Phase B Temperature	Phase B Motor Winding Temperature exceeds Motor Winding Temperature High Alarm Setpoint	Active if Displaying Motor Winding Temperatures
(A065) Alarm: Blower 3 - High Phase C Temperature	Phase C Motor Winding Temperature exceeds Motor Winding Temperature High Alarm Setpoint	Active if Displaying Motor Winding Temperatures
(A066) Alarm: Blower 3 - High ODE Bearing Temperature	Drive End Motor Bearing Temperature exceeds Motor Bearing Temperature High Alarm Setpoint	Active if Displaying Motor Bearing Temperatures
(A067) Alarm: Blower 3 - High DE Bearing Temperature	Opposite Drive End Motor Bearing Temperature exceeds Motor Bearing Temperature High Alarm Setpoint	Active if Displaying Motor Bearing Temperatures
(A068) Alarm: Blower 3 - High Motor Amps	Blower 3 Motor Amps exceeds "Motor Amps" High Alarm Setpoint	
(A069) Alarm: Blower 3 - VFD Speed Reference Fault	Blower 3 Actual Speed is not within 1% of commanded speed.	
(A070) Alarm: Blower 3 - Oil Cooler Fan Fault	Blower 3 Oil Cooler Fan is commanded to run, running confirmation is not received.	Active if an air-cooled oil cooler is installed.
(A071) Alarm:		
(A072) Alarm:		
(A073) Alarm:		
(A074) Alarm:		
(A075) Alarm:		
(A076) Alarm:		
(A077) Alarm:		
(A078) Alarm:		
(A079) Alarm:		
(A080) Alarm: Blower 4 - High Discharge Temperature	Blower 4 Discharge Temperature exceeds "Discharge Temperature" High Alarm Setpoint	
(A081) Alarm: Blower 4 - High Discharge Pressure	Blower 4 Discharge Pressure exceeds "Discharge Pressure" High Alarm Setpoint	
(A082) Alarm: Blower 4 - Low Suction Pressure	Blower 4 Suction Pressure falls below "Suction Pressure" Low Alarm Setpoint	
(A083) Alarm: Blower 4 - High Phase A Temperature	Phase A Motor Winding Temperature exceeds Motor Winding Temperature High Alarm Setpoint	Active if Displaying Motor Winding Temperatures

Section 11 • Alarms, Trips, Status Information & Troubleshooting

Alarm Message	Cause(s)	Notes
(A084) Alarm: Blower 4 - High Phase B Temperature	Phase B Motor Winding Temperature exceeds Motor Winding Temperature High Alarm Setpoint	Active if Displaying Motor Winding Temperatures
(A085) Alarm: Blower 4 - High Phase C Temperature	Phase C Motor Winding Temperature exceeds Motor Winding Temperature High Alarm Setpoint	Active if Displaying Motor Winding Temperatures
(A086) Alarm: Blower 4 - High ODE Bearing Temperature	Drive End Motor Bearing Temperature exceeds Motor Bearing Temperature High Alarm Setpoint	Active if Displaying Motor Bearing Temperatures
(A087) Alarm: Blower 4 - High DE Bearing Temperature	Opposite Drive End Motor Bearing Temperature exceeds Motor Bearing Temperature High Alarm Setpoint	Active if Displaying Motor Bearing Temperatures
(A088) Alarm: Blower 4 - High Motor Amps	Blower 4 Motor Amps exceeds "Motor Amps" High Alarm Setpoint	
(A089) Alarm: Blower 4 - VFD Speed Reference Fault	Blower 4 Actual Speed is not within 1% of commanded speed.	
(A090) Alarm: Blower 4 - Oil Cooler Fan Fault	Blower 4 Oil Cooler Fan is commanded to run, running confirmation is not received.	Active if an air-cooled oil cooler is installed.
(A091) Alarm:		
(A092) Alarm:		
(A093) Alarm:		
(A094) Alarm:		
(A095) Alarm:		
(A096) Alarm:		
(A097) Alarm:		
(A098) Alarm:		
(A099) Alarm:		
(A100) Alarm: Inlet Scrubber High Level	Inlet Scrubber High Liquid Level Switch Activated	Active if Vane Type Inlet Scrubber is Present
(A101) Alarm: Inlet Scrubber High High Level	Inlet Scrubber High High Liquid Level Switch Activated (Selected Action = ALARM)	Active if Vane Type Inlet Scrubber is Present
(A102) Alarm: Inlet Scrubber Low Low Level	Inlet Scrubber Low Low Level Switch Activated (Selected Action = ALARM)	Active if Vane Type Inlet Scrubber is Present
(A103) Alarm: Upper Inlet Scrubber High Level	Inlet Scrubber Upper Section High Level Switch Activated	Active if Coalescing Type Inlet Scrubber is Present
(A104) Alarm: Upper Inlet Scrubber High High Level	Inlet Scrubber Upper Section High High Level Switch Activated (Selected Action = ALARM)	Active if Coalescing Type Inlet Scrubber is Present
(A105) Alarm: (Unassigned)		
(A106) Alarm: Lower Inlet Scrubber High Level	Inlet Scrubber Lower Section High Level Switch Activated	Active if Coalescing Type Inlet Scrubber is Present
(A107) Alarm: Lower Inlet Scrubber High High Level	Inlet Scrubber Lower Section High High Level Switch Activated	Active if Coalescing Type Inlet Scrubber is Present

Section 11 • Alarms, Trips, Status Information & Troubleshooting

Alarm Message	Cause(s)	Notes
(A108) Alarm: Inlet Scrubber High Pressure Drop	Pressure Drop between scrubber inlet and outlet pressure exceeds "Inlet Scrubber Pressure Drop" High Alarm Setpoint	
(A109) Alarm: Inlet Scrubber Condensate Pump Starter Fault	Inlet Scrubber Condensate Pump Commanded to run, run confirmation not received.	Active if Controlling a condensate Pump on Inlet Scrubber
(A110) Alarm: Outlet Scrubber High Level	Outlet Scrubber High Liquid Level Switch Activated	Active if Vane Type Inlet Scrubber is Present
(A111) Alarm: Outlet Scrubber High High Level	Outlet Scrubber High High Liquid Level Switch Activated (Selected Action = ALARM)	Active if Vane Type Inlet Scrubber is Present
(A112) Alarm: Outlet Scrubber Low Low Level	Outlet Scrubber Low Low Level Switch Activated (Selected Action = ALARM)	Active if Vane Type Inlet Scrubber is Present
(A113) Alarm: Upper Outlet Scrubber High Level	Outlet Scrubber Upper Section High Level Switch Activated	Active if Coalescing Type Inlet Scrubber is Present
(A114) Alarm: Upper Outlet Scrubber High High Level	Outlet Scrubber Upper Section High High Level Switch Activated (Selected Action = ALARM)	Active if Coalescing Type Inlet Scrubber is Present
(A115) Alarm: (Unassigned)		
(A116) Alarm: Lower Outlet Scrubber High Level	Outlet Scrubber Lower Section High Level Switch Activated	Active if Coalescing Type Inlet Scrubber is Present
(A117) Alarm: Lower Outlet Scrubber High High Level	Outlet Scrubber Lower Section High High Level Switch Activated	Active if Coalescing Type Inlet Scrubber is Present
(A118) Alarm: Outlet Scrubber High Pressure Drop	Pressure Drop between scrubber inlet and outlet pressure exceeds "Outlet Scrubber Pressure Drop" High Alarm Setpoint	
(A119) Alarm: Outlet Scrubber Condensate Pump Starter Fault	Outlet Scrubber Condensate Pump Commanded to run, run confirmation not received.	Active if Controlling a condensate Pump on Inlet Scrubber
(A120) Alarm: Out Of Range: Inlet Scrubber Inlet Pressure	Inlet Scrubber Inlet Pressure Instrument is Disconnected or Raw value is less than 3.5 mA or Greater than 20.5 mA	Active if an Inlet Scrubber is Present
(A121) Alarm: Out Of Range: Inlet Scrubber Outlet Pressure	Inlet Scrubber Outlet Pressure Instrument is Disconnected or Raw value is less than 3.5 mA or Greater than 20.5 mA	Active if an Inlet Scrubber is Present
(A122) Alarm: Out Of Range: Blower 1 Suction Temperature	Blower 1 Suction Temperature Instrument is Disconnected or Raw value is less than 3.5 mA or Greater than 20.5 mA (if using a 4-20mA Temperature Transmitter).	

Section 11 • Alarms, Trips, Status Information & Troubleshooting

Alarm Message	Cause(s)	Notes
(A123) Alarm: Out Of Range: Blower 2 Suction Temperature	Blower 2 Suction Temperature Instrument is Disconnected or Raw value is less than 3.5 mA or Greater than 20.5 mA (if using a 4-20mA Temperature Transmitter).	
(A124) Alarm: Out Of Range: Blower 3 Suction Temperature	Blower 3 Suction Temperature Instrument is Disconnected or Raw value is less than 3.5 mA or Greater than 20.5 mA (if using a 4-20mA Temperature Transmitter).	
(A125) Alarm: Out Of Range: Blower 4 Suction Temperature	Blower 4 Suction Temperature Instrument is Disconnected or Raw value is less than 3.5 mA or Greater than 20.5 mA (if using a 4-20mA Temperature Transmitter).	
(A126) Alarm: Out Of Range: Aftercooler Outlet Temperature	Aftercooler Outlet Temperature Instrument is Disconnected or Raw value is less than 3.5 mA or Greater than 20.5 mA (if using a 4-20mA Temperature Transmitter).	
(A127) Alarm: Out Of Range: Outlet Scrubber Inlet Pressure	Outlet Scrubber Inlet Pressure Instrument is Disconnected or Raw value is less than 3.5 mA or Greater than 20.5 mA	Active if an Outlet Scrubber is Present
(A128) Alarm: Out Of Range: Outlet Scrubber Outlet Pressure	Outlet Scrubber Outlet Pressure Instrument is Disconnected or Raw value is less than 3.5 mA or Greater than 20.5 mA	Active if an Outlet Scrubber is Present
(A129) Alarm: Out Of Range: Discharge Recycle Control Pressure	Recycle Pressure Instrument is Disconnected or Raw value is less than 3.5 mA or Greater than 20.5 mA	Active if a Recycle Valve is Present

Section 11 • Alarms, Trips, Status Information & Troubleshooting

Trip Listing

Blower will shutdown if active.

Table 11-2. Trip Listing

Trip Message	Cause(s)	Notes
(T001) Trip: MCR Not Energized/E-Stop Active	Emergency Stop Button on PLC Panel Pressed, Loss of Power, External Emergency Stop Device Tripped	
(T002) Trip: PLC to Central Comms Faulted	Loss of Communication with DCS/ Central - Settable Communications Watchdog Timer Expired. (Action on Comm Failure = Trip)	Watchdog Active if Control by Communications is selected
(T003) Trip:		
(T004) Trip: Setpoint out of Range - See Menu Screen		
(T005) Trip: Invalid Blower Configuration	Blower Configuration or Suction/ Discharge Pressure Source is invalid. See Blower Configuration Screen.	
(T006) Trip:		
(T007) Trip: Faulted I/O Module Connection or Module Type		
(T008) Trip:		
(T009) Trip:		
(T010) Trip: Low Suction Header Pressure	Suction Header Pressure drops below "Suction Pressure" Low Trip Setpoint	Active if monitoring Suction Header Pressure
(T011) Trip: High Discharge Header Pressure	Suction Header Pressure rises above "Discharge Pressure" High Trip Setpoint	Active if monitoring Discharge Header Pressure
(T012) Trip:		
(T013) Trip:		
(T014) Trip:		
(T015) Trip: User Defined Trip 1	User defined Trip 1	Message Defined in "Device Names" Screens
(T016) Trip: User Defined Trip 2	User defined Trip 2	Message Defined in "Device Names" Screens
(T017) Trip: User Defined Trip 3	User defined Trip 3	Message Defined in "Device Names" Screens
(T018) Trip: User Defined Trip 4	User defined Trip 4	Message Defined in "Device Names" Screens
(T019) Trip: User Defined Trip 5	User defined Trip 5	Message Defined in "Device Names" Screens
(T020) Trip: Blower 1 - High Discharge Temperature	Blower 1 Discharge Temperature exceeds "Discharge Temperature" High Trip Setpoint	

Section 11 • Alarms, Trips, Status Information & Troubleshooting

Trip Message	Cause(s)	Notes
(T021) Trip: Blower 1 - High Discharge Pressure	Blower 1 Discharge Pressure exceeds "Discharge Pressure" High Trip Setpoint	
(T022) Trip: Blower 1 - Low Suction Pressure	Blower 1 Suction Pressure falls below "Suction Pressure" Low Trip Setpoint	
(T023) Trip: Blower 1 - High Phase A Temperature	Phase A Motor Winding Temperature exceeds Motor Winding Temperature High Trip Setpoint	Active if Displaying Motor Winding Temperatures
(T024) Trip: Blower 1 - High Phase B Temperature	Phase B Motor Winding Temperature exceeds Motor Winding Temperature High Trip Setpoint	Active if Displaying Motor Winding Temperatures
(T025) Trip: Blower 1 - High Phase C Temperature	Phase C Motor Winding Temperature exceeds Motor Winding Temperature High Trip Setpoint	Active if Displaying Motor Winding Temperatures
(T026) Trip: Blower 1 - High ODE Bearing Temperature	Drive End Motor Bearing Temperature exceeds Motor Bearing Temperature High Trip Setpoint	Active if Displaying Motor Bearing Temperatures
(T027) Trip: Blower 1 - High DE Bearing Temperature	Opposite Drive End Motor Bearing Temperature exceeds Motor Bearing Temperature High Trip Setpoint	Active if Displaying Motor Bearing Temperatures
(T028) Trip: Blower 1 - High Motor Amps	Blower 1 Motor Amps exceeds "Motor Amps" High Trip Setpoint	
(T029) Trip: Blower 1 - Low Oil Pressure (Pressure Switch)	Blower 1 Actual Speed is not within 1% of commanded speed.	Active if Oil Pressure safety switch is installed.
(T030) Trip: Blower 1 - VFD Faulted	Fault Contact on Blower 1 VFD is open indicating Drive Fault	
(T031) Trip: Blower 1 Shunt Trip	Blower 1 Motor was detected to be running when not commanded to run - Supplemental Shutdown output is energized.	
(T032) Trip:		
(T033) Trip:		
(T034) Trip:		
(T035) Trip: Blower 1 - Oil Pump Fault	Blower 1 external oil pump is commanded to run but running confirmation is not received.	
(T036) Trip:		
(T037) Trip:		
(T038) Trip:		
(T039) Trip:		
(T040) Trip: Blower 2 - High Discharge Temperature	Blower 2 Discharge Temperature exceeds "Discharge Temperature" High Trip Setpoint	
(T041) Trip: Blower 2 - High Discharge Pressure	Blower 2 Discharge Pressure exceeds "Discharge Pressure" High Trip Setpoint	

Section 11 • Alarms, Trips, Status Information & Troubleshooting

Trip Message	Cause(s)	Notes
(T042) Trip: Blower 2 - Low Suction Pressure	Blower 2 Suction Pressure falls below "Suction Pressure" Low Trip Setpoint	
(T043) Trip: Blower 2 - High Phase A Temperature	Phase A Motor Winding Temperature exceeds Motor Winding Temperature High Trip Setpoint	Active if Displaying Motor Winding Temperatures
(T044) Trip: Blower 2 - High Phase B Temperature	Phase B Motor Winding Temperature exceeds Motor Winding Temperature High Trip Setpoint	Active if Displaying Motor Winding Temperatures
(T045) Trip: Blower 2 - High Phase C Temperature	Phase C Motor Winding Temperature exceeds Motor Winding Temperature High Trip Setpoint	Active if Displaying Motor Winding Temperatures
(T046) Trip: Blower 2 - High ODE Bearing Temperature	Drive End Motor Bearing Temperature exceeds Motor Bearing Temperature High Trip Setpoint	Active if Displaying Motor Bearing Temperatures
(T047) Trip: Blower 2 - High DE Bearing Temperature	Opposite Drive End Motor Bearing Temperature exceeds Motor Bearing Temperature High Trip Setpoint	Active if Displaying Motor Bearing Temperatures
(T048) Trip: Blower 2 - High Motor Amps	Blower 2 Motor Amps exceeds "Motor Amps" High Trip Setpoint	
(T049) Trip: Blower 2 - Low Oil Pressure (Pressure Switch)	Blower 2 Actual Speed is not within 1% of commanded speed.	Active if Oil Pressure safety switch is installed.
(T050) Trip: Blower 2 - VFD Faulted	Fault Contact on Blower 2 VFD is open indicating Drive Fault	
(T051) Trip: Blower 2 Shunt Trip	Blower 2 Motor was detected to be running when not commanded to run - Supplemental Shutdown output is energized.	
(T052) Trip:		
(T053) Trip:		
(T054) Trip:		
(T055) Trip: Blower 2 - Oil Pump Fault	Blower 2 external oil pump is commanded to run but running confirmation is not received.	
(T056) Trip:		
(T057) Trip:		
(T058) Trip:		
(T059) Trip:		
(T060) Trip: Blower 3 - High Discharge Temperature	Blower 3 Discharge Temperature exceeds "Discharge Temperature" High Trip Setpoint	
(T061) Trip: Blower 3 - High Discharge Pressure	Blower 3 Discharge Pressure exceeds "Discharge Pressure" High Trip Setpoint	
(T062) Trip: Blower 3 - Low Suction Pressure	Blower 3 Suction Pressure falls below "Suction Pressure" Low Trip Setpoint	

Section 11 • Alarms, Trips, Status Information & Troubleshooting

Trip Message	Cause(s)	Notes
(T063) Trip: Blower 3 - High Phase A Temperature	Phase A Motor Winding Temperature exceeds Motor Winding Temperature High Trip Setpoint	Active if Displaying Motor Winding Temperatures
(T064) Trip: Blower 3 - High Phase B Temperature	Phase B Motor Winding Temperature exceeds Motor Winding Temperature High Trip Setpoint	Active if Displaying Motor Winding Temperatures
(T065) Trip: Blower 3 - High Phase C Temperature	Phase C Motor Winding Temperature exceeds Motor Winding Temperature High Trip Setpoint	Active if Displaying Motor Winding Temperatures
(T066) Trip: Blower 3 - High ODE Bearing Temperature	Drive End Motor Bearing Temperature exceeds Motor Bearing Temperature High Trip Setpoint	Active if Displaying Motor Bearing Temperatures
(T067) Trip: Blower 3 - High DE Bearing Temperature	Opposite Drive End Motor Bearing Temperature exceeds Motor Bearing Temperature High Trip Setpoint	Active if Displaying Motor Bearing Temperatures
(T068) Trip: Blower 3 - High Motor Amps	Blower 3 Motor Amps exceeds "Motor Amps" High Trip Setpoint	
(T069) Trip: Blower 3 - Low Oil Pressure (Pressure Switch)	Blower 3 Actual Speed is not within 1% of commanded speed.	Active if Oil Pressure safety switch is installed.
(T070) Trip: Blower 3 - VFD Faulted	Fault Contact on Blower 3 VFD is open indicating Drive Fault	
(T071) Trip: Blower 3 Shunt Trip	Blower 3 Motor was detected to be running when not commanded to run - Supplemental Shutdown output is energized.	
(T072) Trip:		
(T073) Trip:		
(T074) Trip:		
(T075) Trip: Blower 3 - Oil Pump Fault	Blower 3 external oil pump is commanded to run but running confirmation is not received.	
(T076) Trip: (Unassigned)		
(T077) Trip: (Unassigned)		
(T078) Trip: (Unassigned)		
(T079) Trip:		
(T080) Trip: Blower 4 - High Discharge Temperature	Blower 4 Discharge Temperature exceeds "Discharge Temperature" High Trip Setpoint	
(T081) Trip: Blower 4 - High Discharge Pressure	Blower 4 Discharge Pressure exceeds "Discharge Pressure" High Trip Setpoint	
(T082) Trip: Blower 4 - Low Suction Pressure	Blower 4 Suction Pressure falls below "Suction Pressure" Low Trip Setpoint	
(T083) Trip: Blower 4 - High Phase A Temperature	Phase A Motor Winding Temperature exceeds Motor Winding Temperature High Trip Setpoint	Active if Displaying Motor Winding Temperatures

Section 11 • Alarms, Trips, Status Information & Troubleshooting

Trip Message	Cause(s)	Notes
(T084) Trip: Blower 4 - High Phase B Temperature	Phase B Motor Winding Temperature exceeds Motor Winding Temperature High Trip Setpoint	Active if Displaying Motor Winding Temperatures
(T085) Trip: Blower 4 - High Phase C Temperature	Phase C Motor Winding Temperature exceeds Motor Winding Temperature High Trip Setpoint	Active if Displaying Motor Winding Temperatures
(T086) Trip: Blower 4 - High ODE Bearing Temperature	Drive End Motor Bearing Temperature exceeds Motor Bearing Temperature High Trip Setpoint	Active if Displaying Motor Bearing Temperatures
(T087) Trip: Blower 4 - High DE Bearing Temperature	Opposite Drive End Motor Bearing Temperature exceeds Motor Bearing Temperature High Trip Setpoint	Active if Displaying Motor Bearing Temperatures
(T088) Trip: Blower 4 - High Motor Amps	Blower 4 Motor Amps exceeds "Motor Amps" High Trip Setpoint	
(T089) Trip: Blower 4 - Low Oil Pressure (Pressure Switch)	Blower 4 Actual Speed is not within 1% of commanded speed.	Active if Oil Pressure safety switch is installed.
(T090) Trip: Blower 4 - VFD Faulted	Fault Contact on Blower 4 VFD is open indicating Drive Fault	
(T091) Trip: Blower 4 Shunt Trip	Blower 4 Motor was detected to be running when not commanded to run - Supplemental Shutdown output is energized.	
(T092) Trip:		
(T093) Trip:		
(T094) Trip:		
(T095) Trip: Blower 4 - Oil Pump Fault	Blower 4 external oil pump is commanded to run but running confirmation is not received.	
(T096) Trip: (Unassigned)		
(T097) Trip: (Unassigned)		
(T098) Trip:		
(T099) Trip: (Unassigned)		
(T100) Trip: (Unassigned)		
(T101) Trip: Inlet Scrubber High High Level	Inlet Scrubber High High Liquid Level Switch Activated (Selected Action = TRIP)	Active if Vane Type Inlet Scrubber is Present
(T102) Trip: Inlet Scrubber Low Low Level	Inlet Scrubber Low Low Liquid Level Switch Activated (Selected Action = TRIP)	Active if Vane Type Inlet Scrubber is Present
(T103) Trip: (Unassigned)		
(A104) Alarm: Upper Inlet Scrubber High High Level	Inlet Scrubber Upper Section High High Liquid Level Switch Activated (Selected Action = TRIP)	Active if Coalescing Type Inlet Scrubber is present
(T105) Trip: (Unassigned)		
(T106) Trip: (Unassigned)		

Section 11 • Alarms, Trips, Status Information & Troubleshooting

Trip Message	Cause(s)	Notes
(T107) Alarm: Lower Inlet Scrubber High High Level	Inlet Scrubber Lower Section High High Liquid Level Switch Activated (Selected Action = TRIP)	Active if Coalescing Type Inlet Scrubber is present
(T108) Trip: (Unassigned)		
(T109) Trip: (Unassigned)		
(T110) Trip: (Unassigned)		
(T111) Alarm: Outlet Scrubber High High Level	Outlet Scrubber High High Liquid Level Switch Activated (Selected Action = TRIP)	Active if Vane Type Outlet Scrubber is Present
(T112) Alarm: Outlet Scrubber Low Low Level	Outlet Scrubber Low Low Liquid Level Switch Activated (Selected Action = TRIP)	Active if Vane Type Outlet Scrubber is Present
(T113) Trip: (Unassigned)		
(T114) Alarm: Upper Outlet Scrubber High High Level	Outlet Scrubber Upper Section High High Liquid Level Switch Activated (Selected Action = TRIP)	Active if Coalescing Type Outlet Scrubber is present
(T115) Trip: (Unassigned)		
(T116) Trip: (Unassigned)		
(T117) Alarm: Lower Outlet Scrubber High High Level	Outlet Scrubber Lower Section High High Liquid Level Switch Activated (Selected Action = TRIP)	Active if Coalescing Type Outlet Scrubber is present
(T118) Trip: (Unassigned)		
(T119) Trip: (Unassigned)		
(T120) Trip: Out Of Range: Suction Header Pressure	Pressure Instrument is Disconnected or Raw Value is less than 3.5 mA or greater than 20 mA	Active if Suction Header Pressure is Being Monitored
(T121) Trip: Out Of Range: Blower 1 Suction Pressure	Pressure Instrument is Disconnected or Raw Value is less than 3.5 mA or greater than 20 mA	
(T122) Trip: Out Of Range: Blower 1 Discharge Pressure	Pressure Instrument is Disconnected or Raw Value is less than 3.5 mA or greater than 20 mA	
(T123) Trip: Out Of Range: Blower 1 Discharge Temperature	RTD Input is Disconnected or Raw Value is less than 3.5 mA or greater than 20 mA (If using 4-20mA Transmitter)	
(T124) Trip: Out Of Range: Blower 1 Phase A Temperature	RTD Input is Disconnected or Raw Value is less than 3.5 mA or greater than 20 mA (If using 4-20mA Transmitter)	Active if Winding Temperatures are being monitored.
(T125) Trip: Out Of Range: Blower 1 Phase B Temperature	RTD Input is Disconnected or Raw Value is less than 3.5 mA or greater than 20 mA (If using 4-20mA Transmitter)	Active if Winding Temperatures are being monitored.
(T126) Trip: Out Of Range: Blower 1 Phase C Temperature	RTD Input is Disconnected or Raw Value is less than 3.5 mA or greater than 20 mA (If using 4-20mA Transmitter)	Active if Winding Temperatures are being monitored.

Section 11 • Alarms, Trips, Status Information & Troubleshooting

Trip Message	Cause(s)	Notes
(T127) Trip: Out Of Range: Blower 1 ODE Temperature	RTD Input is Disconnected or Raw Value is less than 3.5 mA or greater than 20 mA (If using 4-20mA Transmitter)	Active if Bearing Temperatures are being monitored.
(T128) Trip: Out Of Range: Blower 1 DE Temperature	RTD Input is Disconnected or Raw Value is less than 3.5 mA or greater than 20 mA (If using 4-20mA Transmitter)	Active if Bearing Temperatures are being monitored.
(T129) Trip: Out Of Range: Blower 1 Motor Amps	Motor Amps input is Disconnected or Raw Value is less than 3.5 mA or greater than 20 mA	
(T130) Trip: Out Of Range: Blower 2 Suction Pressure	Pressure Instrument is Disconnected or Raw Value is less than 3.5 mA or greater than 20 mA	
(T131) Trip: Out Of Range: Blower 2 Discharge Pressure	Pressure Instrument is Disconnected or Raw Value is less than 3.5 mA or greater than 20 mA	
(T132) Trip: Out Of Range: Blower 2 Discharge Temperature	RTD Input is Disconnected or Raw Value is less than 3.5 mA or greater than 20 mA (If using 4-20mA Transmitter)	
(T133) Trip: Out Of Range: Blower 2 Phase A Temperature	RTD Input is Disconnected or Raw Value is less than 3.5 mA or greater than 20 mA (If using 4-20mA Transmitter)	Active if Winding Temperatures are being monitored.
(T134) Trip: Out Of Range: Blower 2 Phase B Temperature	RTD Input is Disconnected or Raw Value is less than 3.5 mA or greater than 20 mA (If using 4-20mA Transmitter)	Active if Winding Temperatures are being monitored.
(T135) Trip: Out Of Range: Blower 2 Phase C Temperature	RTD Input is Disconnected or Raw Value is less than 3.5 mA or greater than 20 mA (If using 4-20mA Transmitter)	Active if Winding Temperatures are being monitored.
(T136) Trip: Out Of Range: Blower 2 ODE Temperature	RTD Input is Disconnected or Raw Value is less than 3.5 mA or greater than 20 mA (If using 4-20mA Transmitter)	Active if Bearing Temperatures are being monitored.
(T137) Trip: Out Of Range: Blower 2 DE Temperature	RTD Input is Disconnected or Raw Value is less than 3.5 mA or greater than 20 mA (If using 4-20mA Transmitter)	Active if Bearing Temperatures are being monitored.
(T138) Trip: Out Of Range: Blower 2 Motor Amps	Motor Amps input is Disconnected or Raw Value is less than 3.5 mA or greater than 20 mA	
(T139) Trip: Out Of Range: Blower 3 Suction Pressure	Pressure Instrument is Disconnected or Raw Value is less than 3.5 mA or greater than 20 mA	

Section 11 • Alarms, Trips, Status Information & Troubleshooting

Trip Message	Cause(s)	Notes
(T140) Trip: Out Of Range: Blower 3 Discharge Pressure	Pressure Instrument is Disconnected or Raw Value is less than 3.5 mA or greater than 20 mA	
(T141) Trip: Out Of Range: Blower 3 Discharge Temperature	RTD Input is Disconnected or Raw Value is less than 3.5 mA or greater than 20 mA (If using 4-20mA Transmitter)	
(T142) Trip: Out Of Range: Blower 3 Phase A Temperature	RTD Input is Disconnected or Raw Value is less than 3.5 mA or greater than 20 mA (If using 4-20mA Transmitter)	Active if Winding Temperatures are being monitored.
(T143) Trip: Out Of Range: Blower 3 Phase B Temperature	RTD Input is Disconnected or Raw Value is less than 3.5 mA or greater than 20 mA (If using 4-20mA Transmitter)	Active if Winding Temperatures are being monitored.
(T144) Trip: Out Of Range: Blower 3 Phase C Temperature	RTD Input is Disconnected or Raw Value is less than 3.5 mA or greater than 20 mA (If using 4-20mA Transmitter)	Active if Winding Temperatures are being monitored.
(T145) Trip: Out Of Range: Blower 3 ODE Temperature	RTD Input is Disconnected or Raw Value is less than 3.5 mA or greater than 20 mA (If using 4-20mA Transmitter)	Active if Bearing Temperatures are being monitored.
(T146) Trip: Out Of Range: Blower 3 DE Temperature	RTD Input is Disconnected or Raw Value is less than 3.5 mA or greater than 20 mA (If using 4-20mA Transmitter)	Active if Bearing Temperatures are being monitored.
(T147) Trip: Out Of Range: Blower 3 Motor Amps	Motor Amps input is Disconnected or Raw Value is less than 3.5 mA or greater than 20 mA	
(T148) Trip: Out Of Range: Blower 4 Suction Pressure	Pressure Instrument is Disconnected or Raw Value is less than 3.5 mA or greater than 20 mA	
(T149) Trip: Out Of Range: Blower 4 Discharge Pressure	Pressure Instrument is Disconnected or Raw Value is less than 3.5 mA or greater than 20 mA	
(T150) Trip: Out Of Range: Blower 4 Discharge Temperature	RTD Input is Disconnected or Raw Value is less than 3.5 mA or greater than 20 mA (If using 4-20mA Transmitter)	
(T151) Trip: Out Of Range: Blower 4 Phase A Temperature	RTD Input is Disconnected or Raw Value is less than 3.5 mA or greater than 20 mA (If using 4-20mA Transmitter)	Active if Winding Temperatures are being monitored.
(T152) Trip: Out Of Range: Blower 4 Phase B Temperature	RTD Input is Disconnected or Raw Value is less than 3.5 mA or greater than 20 mA (If using 4-20mA Transmitter)	Active if Winding Temperatures are being monitored.

Section 11 • Alarms, Trips, Status Information & Troubleshooting

Trip Message	Cause(s)	Notes
(T153) Trip: Out Of Range: Blower 4 Phase C Temperature	RTD Input is Disconnected or Raw Value is less than 3.5 mA or greater than 20 mA (If using 4-20mA Transmitter)	Active if Winding Temperatures are being monitored.
(T154) Trip: Out Of Range: Blower 4 ODE Temperature	RTD Input is Disconnected or Raw Value is less than 3.5 mA or greater than 20 mA (If using 4-20mA Transmitter)	Active if Bearing Temperatures are being monitored.
(T155) Trip: Out Of Range: Blower 4 DE Temperature	RTD Input is Disconnected or Raw Value is less than 3.5 mA or greater than 20 mA (If using 4-20mA Transmitter)	Active if Bearing Temperatures are being monitored.
(T156) Trip: Out Of Range: Blower 4 Motor Amps	Motor Amps input is Disconnected or Raw Value is less than 3.5 mA or greater than 20 mA	
(T157) Trip: Unassigned		
(T158) Trip: Unassigned		
(T159) Trip: Unassigned		

Status Messages and Blower State Indicator

Status messages are used to indicate blower status information to the user. Status messages are used to inform the user of any of the following conditions.

- Anti-Recycle Timer is active
- Blower Package is in standby mode and is waiting for one or more conditions to be met
- Load Limits and Forced Unloading
- Blower PLC has automatically reverted to Local-Auto mode on loss of communications with central controller or DCS (if this function is enabled)
- A user is logged in
- An output is forced

Status messages are shown in a green scrolling banner at the top of the overview and menu screens.



Figure 11-3. Alarm/Trip/Status Bars (Main Menu Screen)

Table 11-3. Status Listing

Status Message	Notes
(S001) Status: Blower 1 Stopped	Displayed on the Event List only
(S002) Status: Blower 1 Started	Displayed on the Event List only
(S003) Status: Blower 2 Stopped	Displayed on the Event List only
(S004) Status: Blower 2 Started	Displayed on the Event List only
(S005) Status: Blower 3 Stopped	Displayed on the Event List only
(S006) Status: Blower 3 Started	Displayed on the Event List only
(S007) Status: Blower 4 Stopped	Displayed on the Event List only
(S008) Status: Blower 4 Started	Displayed on the Event List only
(S009) Status: Blower 1 Anti-Recycle	
(S010) Status: Blower 2 Anti-Recycle	
(S011) Status: Blower 3 Anti-Recycle	
(S012) Status: Blower 4 Anti-Recycle	
(S013) Status: Waiting to Start: Remote Run Permissive Input	Blower PLC is waiting for a contact closure on the remote run permissive input before the blowers may start.
(S014) Status: Waiting to Start: Soft Run Permissive from DCS/Central	Blower PLC is waiting for a run command from the central controller or DCS (if control by communications enabled)
(S015) Status: Not Assigned	
(S016) Status: Loading Inhibited: Low Suction Pressure	
(S017) Status: Loading Inhibited: High Discharge Pressure	

Section 11 • Alarms, Trips, Status Information & Troubleshooting

Status Message	Notes
(S018) Status: Not Assigned	
(S019) Status: Forced Unload: Low Suction Pressure	
(S020) Status: Forced Unload: High Discharge Pressure	
(S021) Status: Not Assigned	
(S022) Status: Not Assigned	
(S023) Status: Comms Faulted, Reverted to Local Mode	If "Control by Communications" is enabled and "Alarm and Revert to Local" is selected as the communications fault action.
(S024) Status: User SUPER Logged In	
(S025) Status: User OP1 Logged In	
(S026) Status: User OP2 Logged In	
(S027) Status: User OP3 Logged In	
(S028) Status: User OP4 Logged In	
(S029) Status: User OP5 Logged In	
(S030) Status: Blower 1 Motor Forced ON	
(S031) Status: Blower 2 Motor Forced ON	
(S032) Status: Blower 3 Motor Forced ON	
(S033) Status: Blower 4 Motor Forced ON	
(S034) Status: Blower 1 Oil Cooler Forced ON	
(S035) Status: Blower 2 Oil Cooler Forced ON	
(S036) Status: Blower 3 Oil Cooler Forced ON	
(S037) Status: Blower 4 Oil Cooler Forced ON	
(S038) Status: Blower 1 Oil Pump Forced ON	
(S039) Status: Blower 2 Oil Pump Forced ON	
(S040) Status: Blower 3 Oil Pump Forced ON	
(S041) Status: Blower 4 Oil Pump Forced ON	
(S042) Status: Not Assigned	
(S043) Status: Not Assigned	
(S044) Status: Aftercooler 1 VFD FORCED ON	
(S045) Status: Aftercooler 1 Fan 1 FORCED ON	
(S046) Status: Aftercooler 1 Fan 2 FORCED ON	
(S047) Status: Aftercooler 1 Fan 3 FORCED ON	
(S048) Status: Aftercooler 1 Fan 4 FORCED ON	
(S049) Status: Aftercooler 1 Fan 5 FORCED ON	
(S050) Status: Aftercooler 1 Fan 6 FORCED ON	
(S051) Status: Aftercooler 1 Fan 7 FORCED ON	
(S052) Status: Aftercooler 1 Fan 8 FORCED ON	
(S053) Status: Aftercooler 1 Fan 9 FORCED ON	
(S054) Status: Aftercooler 1 Fan 10 FORCED ON	
(S055) Status: Not Assigned	
(S056) Status: Not Assigned	

Section 11 • Alarms, Trips, Status Information & Troubleshooting

Status Message	Notes
(S057) Status: Not Assigned	
(S058) Status: Not Assigned	
(S059) Status: Not Assigned	
(S060) Status: Not Assigned	
(S061) Status: Blower 1 Supplemental Shutdown Forced ON	
(S062) Status: Blower 2 Supplemental Shutdown Forced ON	
(S063) Status: Blower 3 Supplemental Shutdown Forced ON	
(S064) Status: Blower 4 Supplemental Shutdown Forced ON	
(S065) Status: Not Assigned	
(S066) Status: Not Assigned	
(S067) Status: Not Assigned	
(S068) Status: Not Assigned	
(S069) Status: Not Assigned	
(S070) Status: Not Assigned	
(S071) Status: Not Assigned	
(S072) Status: Not Assigned	
(S073) Status: Not Assigned	
(S074) Status: Not Assigned	
(S075) Status: Not Assigned	
(S076) Status: Not Assigned	
(S077) Status: Not Assigned	
(S078) Status: Not Assigned	
(S079) Status: Not Assigned	
(S080) Status: Discharge Recycle Valve FORCED ON	
(S081) Status: Not Assigned	
(S082) Status: Not Assigned	
(S083) Status: Alarm Indication FORCED ON	
(S084) Status: Trip Indication FORCED ON	
(S085) Status: Not Assigned	
(S086) Status: Not Assigned	
(S087) Status: Not Assigned	
(S088) Status: Not Assigned	
(S089) Status: Not Assigned	
(S090) Status: Not Assigned	
(S091) Status: Inlet Scrubber Drain Pump Forced ON	
(S092) Status: Inlet Scrubber Drain Solenoid Forced ON	
(S093) Status: Outlet Scrubber Drain Pump Forced ON	
(S094) Status: Outlet Scrubber Drain Solenoid Forced ON	

Section 11 • Alarms, Trips, Status Information & Troubleshooting

Status Message	Notes
(S095) Status: Not Assigned	
(S096) Status: Not Assigned	
(S097) Status: Not Assigned	
(S098) Status: Not Assigned	
(S099) Status: Not Assigned	
(S100) Status: Not Assigned	
(S101) Status: Not Assigned	
(S102) Status: Not Assigned	
(S103) Status: Not Assigned	
(S104) Status: INLET SCRUBBER - PUMP 2 FORCED ON	
(S105) Status: OUTLET SCRUBBER - PUMP 2 FORCED ON	
(S106) Status: Not Assigned	
(S107) Status: Not Assigned	
(S108) Status: Not Assigned	
(S109) Status: User MGR Logged In	
(S110) Status: Not Assigned	
(S111) Status: Not Assigned	
(S112) Status: Not Assigned	
(S113) Status: Aftercooler 1 Valve Forced	
(S114) Status: Not Assigned	
(S115) Status: Not Assigned	
(S116) Status: Not Assigned	
(S117) Status: Not Assigned	
(S118) Status: Rung Edit Detected	Indicates that the Blower PLC program has been edited.
(S119) Status: Not Assigned	
(S120) Status: Not Assigned	
(S121) Status: Not Assigned	
(S122) Status: Not Assigned	

Troubleshooting

IF THE BLOWER(S) WILL NOT START

In order to initiate a start at the blower package, make sure all permissives to initiate a start are met.

To initiate a start, the following conditions must be met:

- Control Power is ON (Emergency Stop button is not pressed and Master Control Relay is energized, indicated by pilot light on front of panel)
- No Active Trips

If a start has been initiated and the blower has not started, it is in standby mode. When in standby mode, the status banner will indicate the condition that is preventing the blower from starting.

IF CONTROL POWER WILL NOT TURN ON

If unable to turn on control power/reset an emergency stop, check the following conditions:

To energize the Master Control Relay, the following conditions must be met:

- Blower PLC Panel must be supplied with 120VAC power.
- “Master Power” Selector Switch must be ON
- Local Emergency Stop pushbutton (mounted on PLC enclosure door) must be pulled out.
- DC power supplies must be powered up and functional, “DC OK” Relay must be energized.
- CompactLogix processor must be powered up and functional, “PLC OK” Output must be ON.
- Optional/External Emergency Stop Devices are not tripped.

Communication with a Central Controller/DCS

It is possible for a central controller/DCS to read live data and other information from the blower PLC as well as send commands to the blower PLC. The following section outlines the PLC addresses that are used for interface between the blower PLC and central controller/DCS.

VPN ACCESS

VPN access allows Vilter engineers and technicians connect remotely to the blower PLC for greater ease of support and troubleshooting. If possible, it is recommended that VPN access be provided.

To allow VPN access to a blower PLC, the following are required:

- A physical Ethernet Connection from the blower PLC to the site control network
- IP address, Subnet Mask, and Gateway address must be defined for each blower PLC and HMI on the site control network
- A VPN server linked to the site control network
- VPN server login information

SETTING UP COMMUNICATIONS

The blower PLC communicates using the Ethernet IP protocol. Communication to other devices compatible with Ethernet IP is as simple as setting up CIP message instructions and does not require any additional hardware other than that required for the physical connection.

Interface Data in the blower PLC is organized into arrays for simple access of data. For example, all live instrument data is arranged into a single block 200 elements long. To get all of the data, only one message would need to be configured to read an array of registers, Data type REAL, Length of 200. See the communication tables below for specifics.

NOTE

Setting up communications using a protocol other than Ethernet IP is possible (Example Modbus RTU or Modbus TCP), but additional hardware, software, programming, and setup are required.

WATCHDOG TIMER

A watchdog timer is used to monitor the status of the communication link between the blower PLC and Central Controller/DCS. It is only necessary to write watchdog logic when the Central Controller/DCS is sending

commands to the blower PLC. If reading data only, the Watchdog timer is not used.

The watchdog timer works by “passing a bit” back and forth between the Blower PLC and central controller/DCS. If the blower PLC sees the bit in the same state for a settable watchdog time, the communications are faulted. The Communication fault action is selectable between “Alarm and Revert to Local Mode” or “Trip Machine.” If “Alarm and Revert to Local Mode” is selected, the blower will continue to run if running. If “Trip Machine” is selected, the blower will trip and shut down. The settable watchdog time and communications fault action are selected on the Configuration Screen.

The watchdog bits that are used are:

- Blower to Central/DCS: BOOL_OUT[0].0
- Central/DCS to Blower: BOOL_IN[0].0

When the Blower PLC sees BOOL_IN[0].0 OFF it will turn BOOL_OUT[0].0 ON. To maintain the handshake, the Central Controller/DCS shall Turn BOOL_IN[0].0 ON When it sees BOOL_OUT[0].0 ON.

Data that can be Read from the Blower PLC

LIVE INSTRUMENT DATA

Tags “REAL_OUT[0]” through “REAL_OUT[99]” present the live data values as they appear on the HMI screen in the selected engineering units. The Tags “REAL_OUT[100]” through “REAL_OUT[199]” present all live data values in base units, which are PSIA for pressures and Degrees Fahrenheit for Temperatures. For data other than Pressures and Temperatures, the engineering units are fixed and not selectable, and will appear the same in “REAL_OUT[0]” through “REAL_OUT[99]” as they will in “REAL_OUT[100]” through “REAL_OUT[199].” The engineering units selected are presented in the tags “INT_OUT[0]” through “INT_OUT[99].”

Section 12 • Communications with a Central Controller/DCS

Table 12-1. Engineered Units Value Interpretation (INT_OUT[x])

Pressure Units	INT_OUT[x] Value	Temperature Units	INT_OUT[x] Value
PSIG	0	Degrees Fahrenheit	0
PSIA (PSID)	1	Degrees Celsius	1
kPa[A] (kPa[D])	2	Kelvin	2
kPa[G]	12	Degrees Rankine	3
kg/cm ² [A] (kg/cm ² [D])	3		
kg/cm ² [G]	13		
inHg (vac) PSIG (pressure) (If positive, value is in PSIG. If negative, value is in inches Hg.)	4		
inWC	15		
Bar[A]	6		
Bar[G]	16		
Torr[A]	7		
Torr[G]	17		

Table 12-2. Live Instrument Data

Live Instrument Data: "REAL_OUT" (Data Type = REAL, Length = 200)		
Interface Tag	Description	Units
REAL_OUT[0]	Inlet Scrubber Inlet Pressure	INT_OUT[0]
REAL_OUT[1]	Inlet Scrubber Outlet Pressure	INT_OUT[1]
REAL_OUT[2]	Inlet Scrubber Pressure Drop	INT_OUT[2]
REAL_OUT[3]	Outlet Scrubber Inlet Pressure	INT_OUT[3]
REAL_OUT[4]	Outlet Scrubber Outlet Pressure	INT_OUT[4]
REAL_OUT[5]	Outlet Scrubber Pressure Drop	INT_OUT[5]
REAL_OUT[6]	Suction Header Pressure	INT_OUT[6]
REAL_OUT[7]	Discharge Header Pressure	INT_OUT[7]
REAL_OUT[8]	Aftercooler 1 Outlet Temp	INT_OUT[8]
REAL_OUT[9]	Aftercooler 1 VFD Speed	% Speed (100%=60Hz)
REAL_OUT[10]	Discharge Recycle Control Pressure	INT_OUT[10]
REAL_OUT[11]	Discharge Recycle Commanded Postion	% Position
REAL_OUT[12]		
REAL_OUT[13]		
REAL_OUT[14]		
REAL_OUT[15]		
REAL_OUT[16]		
REAL_OUT[17]		
REAL_OUT[18]		
REAL_OUT[19]		

Section 12 • Communications with a Central Controller/DCS

Interface Tag	Description	Units
REAL_OUT[20]	Blower 1 Suction Temperature	INT_OUT[20]
REAL_OUT[21]	Blower 1 Discharge Temperature	INT_OUT[21]
REAL_OUT[22]	Blower 1 Suction Pressure	INT_OUT[22]
REAL_OUT[23]	Blower 1 Discharge Pressure	INT_OUT[23]
REAL_OUT[24]	Blower 1 Commanded Speed	% Speed (100%=60Hz)
REAL_OUT[25]	Blower 1 Actual Speed	% Speed (100%=60Hz)
REAL_OUT[26]	Blower 1 Motor Amps	Amps
REAL_OUT[27]	Blower 1 Phase A Temperature	INT_OUT[27]
REAL_OUT[28]	Blower 1 Phase B Temperature	INT_OUT[28]
REAL_OUT[29]	Blower 1 Phase C Temperature	INT_OUT[29]
REAL_OUT[30]	Blower 1 ODE Bearing Temp	INT_OUT[30]
REAL_OUT[31]	Blower 1 DE Bearing Temp	INT_OUT[31]
REAL_OUT[32]	Blower 1 Runtime Hours	Hours
REAL_OUT[33]	Blower 1 Runtime Minutes	Minutes
REAL_OUT[34]		
REAL_OUT[35]		
REAL_OUT[36]		
REAL_OUT[37]		
REAL_OUT[38]		
REAL_OUT[39]		
REAL_OUT[40]	Blower 2 Suction Temperature	INT_OUT[40]
REAL_OUT[41]	Blower 2 Discharge Temperature	INT_OUT[41]
REAL_OUT[42]	Blower 2 Suction Pressure	INT_OUT[42]
REAL_OUT[43]	Blower 2 Discharge Pressure	INT_OUT[43]
REAL_OUT[44]	Blower 2 Commanded Speed	% Speed (100%=60Hz)
REAL_OUT[45]	Blower 2 Actual Speed	% Speed (100%=60Hz)
REAL_OUT[46]	Blower 2 Motor Amps	Amps
REAL_OUT[47]	Blower 2 Phase A Temperature	INT_OUT[47]
REAL_OUT[48]	Blower 2 Phase B Temperature	INT_OUT[48]
REAL_OUT[49]	Blower 2 Phase C Temperature	INT_OUT[49]
REAL_OUT[50]	Blower 2 ODE Bearing Temp	INT_OUT[50]
REAL_OUT[51]	Blower 2 DE Bearing Temp	INT_OUT[51]
REAL_OUT[52]	Blower 2 Runtime Hours	Hours
REAL_OUT[53]	Blower 2 Runtime Minutes	Minutes
REAL_OUT[54]		
REAL_OUT[55]		
REAL_OUT[56]		
REAL_OUT[57]		
REAL_OUT[58]		
REAL_OUT[59]		
REAL_OUT[60]	Blower 3 Suction Temperature	INT_OUT[60]

Section 12 • Communications with a Central Controller/DCS

Interface Tag	Description	Units
REAL_OUT[61]	Blower 3 Discharge Temperature	INT_OUT[61]
REAL_OUT[62]	Blower 3 Suction Pressure	INT_OUT[62]
REAL_OUT[63]	Blower 3 Discharge Pressure	INT_OUT[63]
REAL_OUT[64]	Blower 3 Commanded Speed	% Speed (100%=60Hz)
REAL_OUT[65]	Blower 3 Actual Speed	% Speed (100%=60Hz)
REAL_OUT[66]	Blower 3 Motor Amps	Amps
REAL_OUT[67]	Blower 3 Phase A Temperature	INT_OUT[67]
REAL_OUT[68]	Blower 3 Phase B Temperature	INT_OUT[68]
REAL_OUT[69]	Blower 3 Phase C Temperature	INT_OUT[69]
REAL_OUT[70]	Blower 3 ODE Bearing Temp	INT_OUT[70]
REAL_OUT[71]	Blower 3 DE Bearing Temp	INT_OUT[71]
REAL_OUT[72]	Blower 3 Runtime Hours	Hours
REAL_OUT[73]	Blower 3 Runtime Minutes	Minutes
REAL_OUT[74]		
REAL_OUT[75]		
REAL_OUT[76]		
REAL_OUT[77]		
REAL_OUT[78]		
REAL_OUT[79]		
REAL_OUT[80]	Blower 4 Suction Temperature	INT_OUT[80]
REAL_OUT[81]	Blower 4 Discharge Temperature	INT_OUT[81]
REAL_OUT[82]	Blower 4 Suction Pressure	INT_OUT[82]
REAL_OUT[83]	Blower 4 Discharge Pressure	INT_OUT[83]
REAL_OUT[84]	Blower 4 Commanded Speed	% Speed (100%=60Hz)
REAL_OUT[85]	Blower 4 Actual Speed	% Speed (100%=60Hz)
REAL_OUT[86]	Blower 4 Motor Amps	Amps
REAL_OUT[87]	Blower 4 Phase A Temperature	INT_OUT[87]
REAL_OUT[88]	Blower 4 Phase B Temperature	INT_OUT[88]
REAL_OUT[89]	Blower 4 Phase C Temperature	INT_OUT[89]
REAL_OUT[90]	Blower 4 ODE Bearing Temp	INT_OUT[90]
REAL_OUT[91]	Blower 4 DE Bearing Temp	INT_OUT[91]
REAL_OUT[92]	Blower 4 Runtime Hours	Hours
REAL_OUT[93]	Blower 4 Runtime Minutes	Minutes
REAL_OUT[94]		
REAL_OUT[95]		
REAL_OUT[96]		
REAL_OUT[97]		
REAL_OUT[98]		
REAL_OUT[99]		
REAL_OUT[100]	Inlet Scrubber Inlet Pressure	PSIA
REAL_OUT[101]	Inlet Scrubber Outlet Pressure	PSIA

Section 12 • Communications with a Central Controller/DCS

Interface Tag	Description	Units
REAL_OUT[102]	Inlet Scrubber Pressure Drop	PSID
REAL_OUT[103]	Outlet Scrubber Inlet Pressure	PSIA
REAL_OUT[104]	Outlet Scrubber Outlet Pressure	PSIA
REAL_OUT[105]	Outlet Scrubber Pressure Drop	PSID
REAL_OUT[106]	Suction Header Pressure	PSIA
REAL_OUT[107]	Discharge Header Pressure	PSIA
REAL_OUT[108]	Aftercooler 1 Outlet Temp	DEG F
REAL_OUT[109]	Aftercooler 1 VFD Speed	% Speed (100%=60Hz)
REAL_OUT[110]	Discharge Recycle Control Pressure	PSIA
REAL_OUT[111]	Discharge Recycle Commanded Postion	% Position
REAL_OUT[112]		
REAL_OUT[113]		
REAL_OUT[114]		
REAL_OUT[115]		
REAL_OUT[116]		
REAL_OUT[117]		
REAL_OUT[118]		
REAL_OUT[119]		
REAL_OUT[120]	Blower 1 Suction Temperature	DEG F
REAL_OUT[121]	Blower 1 Discharge Temperature	DEG F
REAL_OUT[122]	Blower 1 Suction Pressure	PSIA
REAL_OUT[123]	Blower 1 Discharge Pressure	PSIA
REAL_OUT[124]	Blower 1 Commanded Speed	% Speed (100%=60Hz)
REAL_OUT[125]	Blower 1 Actual Speed	% Speed (100%=60Hz)
REAL_OUT[126]	Blower 1 Motor Amps	Amps
REAL_OUT[127]	Blower 1 Phase A Temperature	DEG F
REAL_OUT[128]	Blower 1 Phase B Temperature	DEG F
REAL_OUT[129]	Blower 1 Phase C Temperature	DEG F
REAL_OUT[130]	Blower 1 ODE Bearing Temp	DEG F
REAL_OUT[131]	Blower 1 DE Bearing Temp	DEG F
REAL_OUT[132]	Blower 1 Runtime Hours	Hours
REAL_OUT[133]	Blower 1 Runtime Minutes	Minutes
REAL_OUT[134]		
REAL_OUT[135]		
REAL_OUT[136]		
REAL_OUT[137]		
REAL_OUT[138]		
REAL_OUT[139]		
REAL_OUT[140]	Blower 2 Suction Temperature	DEG F
REAL_OUT[141]	Blower 2 Discharge Temperature	DEG F
REAL_OUT[142]	Blower 2 Suction Pressure	PSIA

Section 12 • Communications with a Central Controller/DCS

Interface Tag	Description	Units
REAL_OUT[143]	Blower 2 Discharge Pressure	PSIA
REAL_OUT[144]	Blower 2 Commanded Speed	% Speed (100%=60Hz)
REAL_OUT[145]	Blower 2 Actual Speed	% Speed (100%=60Hz)
REAL_OUT[146]	Blower 2 Motor Amps	Amps
REAL_OUT[147]	Blower 2 Phase A Temperature	DEG F
REAL_OUT[148]	Blower 2 Phase B Temperature	DEG F
REAL_OUT[149]	Blower 2 Phase C Temperature	DEG F
REAL_OUT[150]	Blower 2 ODE Bearing Temp	DEG F
REAL_OUT[151]	Blower 2 DE Bearing Temp	DEG F
REAL_OUT[152]	Blower 2 Runtime Hours	Hours
REAL_OUT[153]	Blower 2 Runtime Minutes	Minutes
REAL_OUT[154]		
REAL_OUT[155]		
REAL_OUT[156]		
REAL_OUT[157]		
REAL_OUT[158]		
REAL_OUT[159]		
REAL_OUT[160]	Blower 3 Suction Temperature	DEG F
REAL_OUT[161]	Blower 3 Discharge Temperature	DEG F
REAL_OUT[162]	Blower 3 Suction Pressure	PSIA
REAL_OUT[163]	Blower 3 Discharge Pressure	PSIA
REAL_OUT[164]	Blower 3 Commanded Speed	% Speed (100%=60Hz)
REAL_OUT[165]	Blower 3 Actual Speed	% Speed (100%=60Hz)
REAL_OUT[166]	Blower 3 Motor Amps	Amps
REAL_OUT[167]	Blower 3 Phase A Temperature	DEG F
REAL_OUT[168]	Blower 3 Phase B Temperature	DEG F
REAL_OUT[169]	Blower 3 Phase C Temperature	DEG F
REAL_OUT[170]	Blower 3 ODE Bearing Temp	DEG F
REAL_OUT[171]	Blower 3 DE Bearing Temp	DEG F
REAL_OUT[172]	Blower 3 Runtime Hours	Hours
REAL_OUT[173]	Blower 3 Runtime Minutes	Minutes
REAL_OUT[174]		
REAL_OUT[175]		
REAL_OUT[176]		
REAL_OUT[177]		
REAL_OUT[178]		
REAL_OUT[179]		
REAL_OUT[180]	Blower 4 Suction Temperature	DEG F
REAL_OUT[181]	Blower 4 Discharge Temperature	DEG F
REAL_OUT[182]	Blower 4 Suction Pressure	PSIA

Section 12 • Communications with a Central Controller/DCS

Interface Tag	Description	Units
REAL_OUT[183]	Blower 4 Discharge Pressure	PSIA
REAL_OUT[184]	Blower 4 Commanded Speed	% Speed (100%=60Hz)
REAL_OUT[185]	Blower 4 Actual Speed	% Speed (100%=60Hz)
REAL_OUT[186]	Blower 4 Motor Amps	Amps
REAL_OUT[187]	Blower 4 Phase A Temperature	DEG F
REAL_OUT[188]	Blower 4 Phase B Temperature	DEG F
REAL_OUT[189]	Blower 4 Phase C Temperature	DEG F
REAL_OUT[190]	Blower 4 ODE Bearing Temp	DEG F
REAL_OUT[191]	Blower 4 DE Bearing Temp	DEG F
REAL_OUT[192]	Blower 4 Runtime Hours	Hours
REAL_OUT[193]	Blower 4 Runtime Minutes	Minutes
REAL_OUT[194]		
REAL_OUT[195]		
REAL_OUT[196]		
REAL_OUT[197]		
REAL_OUT[198]		
REAL_OUT[199]		

Alarm and Trip Data

Alarm and Trip Data is presented in Double Integer Format. To interpret the Alarm and Trip data, it is necessary to address the specific bits of the Double Integer.

Table 12-3. Alarm Data

ALARMS AND TRIPS (Data Type = DINT)	
Interface Tag	Description
BOOL_OUT[1].0	(A001) Alarm:
BOOL_OUT[1].1	(A002) Alarm: PLC to Central Comms Faulted
BOOL_OUT[1].2	(A003) Alarm:
BOOL_OUT[1].3	(A004) Alarm:
BOOL_OUT[1].4	(A005) Alarm:
BOOL_OUT[1].5	(A006) Alarm:
BOOL_OUT[1].6	(A007) Alarm:
BOOL_OUT[1].7	(A008) Alarm:
BOOL_OUT[1].8	(A009) Alarm:
BOOL_OUT[1].9	(A010) Alarm: Low Suction Header Pressure
BOOL_OUT[1].10	(A011) Alarm: High Discharge Header Pressure
BOOL_OUT[1].11	(A012) Alarm: Aftercooler VFD Fault
BOOL_OUT[1].12	(A013) Alarm: Aftercooler Fan Starter Fault
BOOL_OUT[1].13	(A014) Alarm:
BOOL_OUT[1].14	(A015) Alarm: User Defined Alarm 1
BOOL_OUT[1].15	(A016) Alarm: User Defined Alarm 2
BOOL_OUT[1].16	(A017) Alarm: User Defined Alarm 3
BOOL_OUT[1].17	(A018) Alarm: User Defined Alarm 4
BOOL_OUT[1].18	(A019) Alarm: User Defined Alarm 5
BOOL_OUT[1].19	(A020) Alarm: Blower 1 - High Discharge Temperature
BOOL_OUT[1].20	(A021) Alarm: Blower 1 - High Discharge Pressure
BOOL_OUT[1].21	(A022) Alarm: Blower 1 - Low Suction Pressure
BOOL_OUT[1].22	(A023) Alarm: Blower 1 - High Phase A Temperature
BOOL_OUT[1].23	(A024) Alarm: Blower 1 - High Phase B Temperature
BOOL_OUT[1].24	(A025) Alarm: Blower 1 - High Phase C Temperature
BOOL_OUT[1].25	(A026) Alarm: Blower 1 - High ODE Bearing Temperature
BOOL_OUT[1].26	(A027) Alarm: Blower 1 - High DE Bearing Temperature
BOOL_OUT[1].27	(A028) Alarm: Blower 1 - High Motor Amps
BOOL_OUT[1].28	(A029) Alarm: Blower 1 - VFD Speed Reference Fault
BOOL_OUT[1].29	(A030) Alarm: Blower 1 - Oil Cooler Fan Fault
BOOL_OUT[1].30	(A031) Alarm:
BOOL_OUT[1].31	(A032) Alarm:
BOOL_OUT[2].0	(A033) Alarm:

Section 12 • Communications with a Central Controller/DCS

Interface Tag	Description
BOOL_OUT[2].1	(A034) Alarm:
BOOL_OUT[2].2	(A035) Alarm:
BOOL_OUT[2].3	(A036) Alarm:
BOOL_OUT[2].4	(A037) Alarm:
BOOL_OUT[2].5	(A038) Alarm:
BOOL_OUT[2].6	(A039) Alarm:
BOOL_OUT[2].7	(A040) Alarm: Blower 2 - High Discharge Temperature
BOOL_OUT[2].8	(A041) Alarm: Blower 2 - High Discharge Pressure
BOOL_OUT[2].9	(A042) Alarm: Blower 2 - Low Suction Pressure
BOOL_OUT[2].10	(A043) Alarm: Blower 2 - High Phase A Temperature
BOOL_OUT[2].11	(A044) Alarm: Blower 2 - High Phase B Temperature
BOOL_OUT[2].12	(A045) Alarm: Blower 2 - High Phase C Temperature
BOOL_OUT[2].13	(A046) Alarm: Blower 2 - High ODE Bearing Temperature
BOOL_OUT[2].14	(A047) Alarm: Blower 2 - High DE Bearing Temperature
BOOL_OUT[2].15	(A048) Alarm: Blower 2 - High Motor Amps
BOOL_OUT[2].16	(A049) Alarm: Blower 2 - VFD Speed Reference Fault
BOOL_OUT[2].17	(A050) Alarm: Blower 2 - Oil Cooler Fan Fault
BOOL_OUT[2].18	(A051) Alarm:
BOOL_OUT[2].19	(A052) Alarm:
BOOL_OUT[2].20	(A053) Alarm:
BOOL_OUT[2].21	(A054) Alarm:
BOOL_OUT[2].22	(A055) Alarm:
BOOL_OUT[2].23	(A056) Alarm:
BOOL_OUT[2].24	(A057) Alarm:
BOOL_OUT[2].25	(A058) Alarm:
BOOL_OUT[2].26	(A059) Alarm:
BOOL_OUT[2].27	(A060) Alarm: Blower 3 - High Discharge Temperature
BOOL_OUT[2].28	(A061) Alarm: Blower 3 - High Discharge Pressure
BOOL_OUT[2].29	(A062) Alarm: Blower 3 - Low Suction Pressure
BOOL_OUT[2].30	(A063) Alarm: Blower 3 - High Phase A Temperature
BOOL_OUT[2].31	(A064) Alarm: Blower 3 - High Phase B Temperature
BOOL_OUT[3].0	(A065) Alarm: Blower 3 - High Phase C Temperature
BOOL_OUT[3].1	(A066) Alarm: Blower 3 - High ODE Bearing Temperature
BOOL_OUT[3].2	(A067) Alarm: Blower 3 - High DE Bearing Temperature
BOOL_OUT[3].3	(A068) Alarm: Blower 3 - High Motor Amps
BOOL_OUT[3].4	(A069) Alarm: Blower 3 - VFD Speed Reference Fault
BOOL_OUT[3].5	(A070) Alarm: Blower 3 - Oil Cooler Fan Fault
BOOL_OUT[3].6	(A071) Alarm:
BOOL_OUT[3].7	(A072) Alarm:
BOOL_OUT[3].8	(A073) Alarm:
BOOL_OUT[3].9	(A074) Alarm:

Section 12 • Communications with a Central Controller/DCS

Interface Tag	Description
BOOL_OUT[3].10	(A075) Alarm:
BOOL_OUT[3].11	(A076) Alarm:
BOOL_OUT[3].12	(A077) Alarm:
BOOL_OUT[3].13	(A078) Alarm:
BOOL_OUT[3].14	(A079) Alarm:
BOOL_OUT[3].15	(A080) Alarm: Blower 4 - High Discharge Temperature
BOOL_OUT[3].16	(A081) Alarm: Blower 4 - High Discharge Pressure
BOOL_OUT[3].17	(A082) Alarm: Blower 4 - Low Suction Pressure
BOOL_OUT[3].18	(A083) Alarm: Blower 4 - High Phase A Temperature
BOOL_OUT[3].19	(A084) Alarm: Blower 4 - High Phase B Temperature
BOOL_OUT[3].20	(A085) Alarm: Blower 4 - High Phase C Temperature
BOOL_OUT[3].21	(A086) Alarm: Blower 4 - High ODE Bearing Temperature
BOOL_OUT[3].22	(A087) Alarm: Blower 4 - High DE Bearing Temperature
BOOL_OUT[3].23	(A088) Alarm: Blower 4 - High Motor Amps
BOOL_OUT[3].24	(A089) Alarm: Blower 4 - VFD Speed Reference Fault
BOOL_OUT[3].25	(A090) Alarm: Blower 4 - Oil Cooler Fan Fault
BOOL_OUT[3].26	(A091) Alarm:
BOOL_OUT[3].27	(A092) Alarm:
BOOL_OUT[3].28	(A093) Alarm:
BOOL_OUT[3].29	(A094) Alarm:
BOOL_OUT[3].30	(A095) Alarm:
BOOL_OUT[3].31	(A096) Alarm:
BOOL_OUT[4].0	(A097) Alarm:
BOOL_OUT[4].1	(A098) Alarm:
BOOL_OUT[4].2	(A099) Alarm:
BOOL_OUT[4].3	(A100) Alarm: Inlet Scrubber High Level
BOOL_OUT[4].4	(A101) Alarm: Inlet Scrubber High High Level
BOOL_OUT[4].5	(A102) Alarm: Inlet Scrubber Low Low Level
BOOL_OUT[4].6	(A103) Alarm: Upper Inlet Scrubber High Level
BOOL_OUT[4].7	(A104) Alarm: Upper Inlet Scrubber High High Level
BOOL_OUT[4].8	(A105) Alarm: (Unassigned)
BOOL_OUT[4].9	(A106) Alarm: Lower Inlet Scrubber High Level
BOOL_OUT[4].10	(A107) Alarm: Lower Inlet Scrubber High High Level
BOOL_OUT[4].11	(A108) Alarm: Inlet Scrubber High Pressure Drop
BOOL_OUT[4].12	(A109) Alarm: Inlet Scrubber Condensate Pump Starter Fault
BOOL_OUT[4].13	(A110) Alarm: Outlet Scrubber High Level
BOOL_OUT[4].14	(A111) Alarm: Outlet Scrubber High High Level
BOOL_OUT[4].15	(A112) Alarm: Outlet Scrubber Low Low Level
BOOL_OUT[4].16	(A113) Alarm: Upper Outlet Scrubber High Level
BOOL_OUT[4].17	(A114) Alarm: Upper Outlet Scrubber High High Level
BOOL_OUT[4].18	(A115) Alarm: (Unassigned)

Section 12 • Communications with a Central Controller/DCS

Interface Tag	Description
BOOL_OUT[4].19	(A116) Alarm: Lower Outlet Scrubber High Level
BOOL_OUT[4].20	(A117) Alarm: Lower Outlet Scrubber High High Level
BOOL_OUT[4].21	(A118) Alarm: Outlet Scrubber High Pressure Drop
BOOL_OUT[4].22	(A119) Alarm: Outlet Scrubber Condensate Pump Starter Fault
BOOL_OUT[4].23	(A120) Alarm: Out Of Range: Inlet Scrubber Inlet Pressure
BOOL_OUT[4].24	(A121) Alarm: Out Of Range: Inlet Scrubber Outlet Pressure
BOOL_OUT[4].25	(A122) Alarm: Out Of Range: Blower 1 Suction Temperature
BOOL_OUT[4].26	(A123) Alarm: Out Of Range: Blower 2 Suction Temperature
BOOL_OUT[4].27	(A124) Alarm: Out Of Range: Blower 3 Suction Temperature
BOOL_OUT[4].28	(A125) Alarm: Out Of Range: Blower 4 Suction Temperature
BOOL_OUT[4].29	(A126) Alarm: Out Of Range: Aftercooler Outlet Temperature
BOOL_OUT[4].30	(A127) Alarm: Out Of Range: Outlet Scrubber Inlet Pressure
BOOL_OUT[4].31	(A128) Alarm: Out Of Range: Outlet Scrubber Outlet Pressure
BOOL_OUT[5].0	(A129) Alarm: Out Of Range: Discharge Recycle Control Pressure
BOOL_OUT[5].1	(A130) Alarm: Unassigned
BOOL_OUT[5].2	(A131) Alarm: Unassigned
BOOL_OUT[5].3	(A132) Alarm: Unassigned
BOOL_OUT[5].4	(A133) Alarm: Unassigned
BOOL_OUT[5].5	(A134) Alarm: Unassigned
BOOL_OUT[5].6	(A135) Alarm: Unassigned
BOOL_OUT[5].7	(A136) Alarm: Unassigned
BOOL_OUT[5].8	(A137) Alarm: Unassigned
BOOL_OUT[5].9	(A138) Alarm: Unassigned
BOOL_OUT[5].10	(A139) Alarm: Unassigned
BOOL_OUT[5].11	(A140) Alarm: Unassigned
BOOL_OUT[5].12	(A141) Alarm: Unassigned
BOOL_OUT[5].13	(A142) Alarm: Unassigned
BOOL_OUT[5].14	(A143) Alarm: Unassigned
BOOL_OUT[5].15	(A144) Alarm: Unassigned
BOOL_OUT[5].16	(A145) Alarm: Unassigned
BOOL_OUT[5].17	(A146) Alarm: Unassigned
BOOL_OUT[5].18	(A147) Alarm: Unassigned
BOOL_OUT[5].19	(A148) Alarm: Unassigned
BOOL_OUT[5].20	(A149) Alarm: Unassigned
BOOL_OUT[5].21	(A150) Alarm: Unassigned
BOOL_OUT[5].22	(A151) Alarm: Unassigned
BOOL_OUT[5].23	(A152) Alarm: Unassigned
BOOL_OUT[5].24	(A153) Alarm: Unassigned
BOOL_OUT[5].25	(A154) Alarm: Unassigned
BOOL_OUT[5].26	(A155) Alarm: Unassigned
BOOL_OUT[5].27	(A156) Alarm: Unassigned

Section 12 • Communications with a Central Controller/DCS

Interface Tag	Description
BOOL_OUT[5].28	(A157) Alarm: Unassigned
BOOL_OUT[5].29	(A158) Alarm: Unassigned
BOOL_OUT[5].30	(A159) Alarm: Unassigned
BOOL_OUT[5].31	

Table 12-4. Trip Data

TRIPS (Data Type = Double Integer)	
Interface Tag	Description
BOOL_OUT[11].0	(T001) Trip: MCR Not Energized/E-Stop Active
BOOL_OUT[11].1	(T002) Trip: PLC to Central Comms Faulted
BOOL_OUT[11].2	(T003) Trip:
BOOL_OUT[11].3	(T004) Trip: Setpoint out of Range - See Menu Screen
BOOL_OUT[11].4	(T005) Trip: Invalid Blower Configuration
BOOL_OUT[11].5	(T006) Trip:
BOOL_OUT[11].6	(T007) Trip: Faulted I/O Module Connection or Module Type
BOOL_OUT[11].7	(T008) Trip:
BOOL_OUT[11].8	(T009) Trip:
BOOL_OUT[11].9	(T010) Trip: Low Suction Header Pressure
BOOL_OUT[11].10	(T011) Trip: High Discharge Header Pressure
BOOL_OUT[11].11	(T012) Trip:
BOOL_OUT[11].12	(T013) Trip:
BOOL_OUT[11].13	(T014) Trip:
BOOL_OUT[11].14	(T015) Trip: User Defined Trip 1
BOOL_OUT[11].15	(T016) Trip: User Defined Trip 2
BOOL_OUT[11].16	(T017) Trip: User Defined Trip 3
BOOL_OUT[11].17	(T018) Trip: User Defined Trip 4
BOOL_OUT[11].18	(T019) Trip: User Defined Trip 5
BOOL_OUT[11].19	(T020) Trip: Blower 1 - High Discharge Temperature
BOOL_OUT[11].20	(T021) Trip: Blower 1 - High Discharge Pressure
BOOL_OUT[11].21	(T022) Trip: Blower 1 - Low Suction Pressure
BOOL_OUT[11].22	(T023) Trip: Blower 1 - High Phase A Temperature
BOOL_OUT[11].23	(T024) Trip: Blower 1 - High Phase B Temperature
BOOL_OUT[11].24	(T025) Trip: Blower 1 - High Phase C Temperature
BOOL_OUT[11].25	(T026) Trip: Blower 1 - High ODE Bearing Temperature
BOOL_OUT[11].26	(T027) Trip: Blower 1 - High DE Bearing Temperature
BOOL_OUT[11].27	(T028) Trip: Blower 1 - High Motor Amps
BOOL_OUT[11].28	(T029) Trip: Blower 1 - Low Oil Pressure (Pressure Switch)

Section 12 • Communications with a Central Controller/DCS

Interface Tag	Description
BOOL_OUT[11].29	(T030) Trip: Blower 1 - VFD Faulted
BOOL_OUT[11].30	(T031) Trip:
BOOL_OUT[11].31	(T032) Trip:
BOOL_OUT[12].0	(T033) Trip:
BOOL_OUT[12].1	(T034) Trip:
BOOL_OUT[12].2	(T035) Trip: Blower 1 - Oil Pump Fault
BOOL_OUT[12].3	(T036) Trip:
BOOL_OUT[12].4	(T037) Trip:
BOOL_OUT[12].5	(T038) Trip:
BOOL_OUT[12].6	(T039) Trip:
BOOL_OUT[12].7	(T040) Trip: Blower 2 - High Discharge Temperature
BOOL_OUT[12].8	(T041) Trip: Blower 2 - High Discharge Pressure
BOOL_OUT[12].9	(T042) Trip: Blower 2 - Low Suction Pressure
BOOL_OUT[12].10	(T043) Trip: Blower 2 - High Phase A Temperature
BOOL_OUT[12].11	(T044) Trip: Blower 2 - High Phase B Temperature
BOOL_OUT[12].12	(T045) Trip: Blower 2 - High Phase C Temperature
BOOL_OUT[12].13	(T046) Trip: Blower 2 - High ODE Bearing Temperature
BOOL_OUT[12].14	(T047) Trip: Blower 2 - High DE Bearing Temperature
BOOL_OUT[12].15	(T048) Trip: Blower 2 - High Motor Amps
BOOL_OUT[12].16	(T049) Trip: Blower 2 - Low Oil Pressure (Pressure Switch)
BOOL_OUT[12].17	(T050) Trip: Blower 2 - VFD Faulted
BOOL_OUT[12].18	(T051) Trip:
BOOL_OUT[12].19	(T052) Trip:
BOOL_OUT[12].20	(T053) Trip:
BOOL_OUT[12].21	(T054) Trip:
BOOL_OUT[12].22	(T055) Trip: Blower 2 - Oil Pump Fault
BOOL_OUT[12].23	(T056) Trip:
BOOL_OUT[12].24	(T057) Trip:
BOOL_OUT[12].25	(T058) Trip:
BOOL_OUT[12].26	(T059) Trip:
BOOL_OUT[12].27	(T060) Trip: Blower 3 - High Discharge Temperature
BOOL_OUT[12].28	(T061) Trip: Blower 3 - High Discharge Pressure
BOOL_OUT[12].29	(T062) Trip: Blower 3 - Low Suction Pressure
BOOL_OUT[12].30	(T063) Trip: Blower 3 - High Phase A Temperature
BOOL_OUT[12].31	(T064) Trip: Blower 3 - High Phase B Temperature
BOOL_OUT[13].0	(T065) Trip: Blower 3 - High Phase C Temperature
BOOL_OUT[13].1	(T066) Trip: Blower 3 - High ODE Bearing Temperature
BOOL_OUT[13].2	(T067) Trip: Blower 3 - High DE Bearing Temperature
BOOL_OUT[13].3	(T068) Trip: Blower 3 - High Motor Amps
BOOL_OUT[13].4	(T069) Trip: Blower 3 - Low Oil Pressure (Pressure Switch)
BOOL_OUT[13].5	(T070) Trip: Blower 3 - VFD Faulted

Section 12 • Communications with a Central Controller/DCS

Interface Tag	Description
BOOL_OUT[13].6	(T071) Trip:
BOOL_OUT[13].7	(T072) Trip:
BOOL_OUT[13].8	(T073) Trip:
BOOL_OUT[13].9	(T074) Trip:
BOOL_OUT[13].10	(T075) Trip: Blower 3 - Oil Pump Fault
BOOL_OUT[13].11	(T076) Trip: (Unassigned)
BOOL_OUT[13].12	(T077) Trip: (Unassigned)
BOOL_OUT[13].13	(T078) Trip: (Unassigned)
BOOL_OUT[13].14	(T079) Trip:
BOOL_OUT[13].15	(T080) Trip: Blower 4 - High Discharge Temperature
BOOL_OUT[13].16	(T081) Trip: Blower 4 - High Discharge Pressure
BOOL_OUT[13].17	(T082) Trip: Blower 4 - Low Suction Pressure
BOOL_OUT[13].18	(T083) Trip: Blower 4 - High Phase A Temperature
BOOL_OUT[13].19	(T084) Trip: Blower 4 - High Phase B Temperature
BOOL_OUT[13].20	(T085) Trip: Blower 4 - High Phase C Temperature
BOOL_OUT[13].21	(T086) Trip: Blower 4 - High ODE Bearing Temperature
BOOL_OUT[13].22	(T087) Trip: Blower 4 - High DE Bearing Temperature
BOOL_OUT[13].23	(T088) Trip: Blower 4 - High Motor Amps
BOOL_OUT[13].24	(T089) Trip: Blower 4 - Low Oil Pressure (Pressure Switch)
BOOL_OUT[13].25	(T090) Trip: Blower 4 - VFD Faulted
BOOL_OUT[13].26	(T091) Trip:
BOOL_OUT[13].27	(T092) Trip:
BOOL_OUT[13].28	(T093) Trip:
BOOL_OUT[13].29	(T094) Trip:
BOOL_OUT[13].30	(T095) Trip: Blower 4 - Oil Pump Fault
BOOL_OUT[13].31	(T096) Trip: (Unassigned)
BOOL_OUT[14].0	(T097) Trip: (Unassigned)
BOOL_OUT[14].1	(T098) Trip:
BOOL_OUT[14].2	(T099) Trip: (Unassigned)
BOOL_OUT[14].3	(T100) Trip: (Unassigned)
BOOL_OUT[14].4	(T101) Trip: Inlet Scrubber High High Level
BOOL_OUT[14].5	(T102) Trip: Inlet Scrubber Low Low Level
BOOL_OUT[14].6	(T103) Trip: (Unassigned)
BOOL_OUT[14].7	(A104) Alarm: Upper Inlet Scrubber High High Level
BOOL_OUT[14].8	(T105) Trip: (Unassigned)
BOOL_OUT[14].9	(T106) Trip: (Unassigned)
BOOL_OUT[14].10	(T107) Alarm: Lower Inlet Scrubber High High Level
BOOL_OUT[14].11	(T108) Trip: (Unassigned)
BOOL_OUT[14].12	(T109) Trip: (Unassigned)
BOOL_OUT[14].14	(T110) Trip: (Unassigned)
BOOL_OUT[14].14	(T111) Alarm: Outlet Scrubber High High Level

Section 12 • Communications with a Central Controller/DCS

Interface Tag	Description
BOOL_OUT[14].15	(T112) Alarm: Outlet Scrubber Low Low Level
BOOL_OUT[14].16	(T113) Trip: (Unassigned)
BOOL_OUT[14].17	(T114) Alarm: Upper Outlet Scrubber High High Level
BOOL_OUT[14].18	(T115) Trip: (Unassigned)
BOOL_OUT[14].19	(T116) Trip: (Unassigned)
BOOL_OUT[14].20	(T117) Alarm: Lower Outlet Scrubber High High Level
BOOL_OUT[14].21	(T118) Trip: (Unassigned)
BOOL_OUT[14].22	(T119) Trip: (Unassigned)
BOOL_OUT[14].23	(T120) Trip: Out Of Range: Suction Header Pressure
BOOL_OUT[14].24	(T121) Trip: Out Of Range: Blower 1 Suction Pressure
BOOL_OUT[14].25	(T122) Trip: Out Of Range: Blower 1 Discharge Pressure
BOOL_OUT[14].26	(T123) Trip: Out Of Range: Blower 1 Discharge Temperature
BOOL_OUT[14].27	(T124) Trip: Out Of Range: Blower 1 Phase A Temperature
BOOL_OUT[14].28	(T125) Trip: Out Of Range: Blower 1 Phase B Temperature
BOOL_OUT[14].29	(T126) Trip: Out Of Range: Blower 1 Phase C Temperature
BOOL_OUT[14].30	(T127) Trip: Out Of Range: Blower 1 ODE Temperature
BOOL_OUT[14].31	(T128) Trip: Out Of Range: Blower 1 DE Temperature
BOOL_OUT[15].0	(T129) Trip: Out Of Range: Blower 1 Motor Amps
BOOL_OUT[15].1	(T130) Trip: Out Of Range: Blower 2 Suction Pressure
BOOL_OUT[15].2	(T131) Trip: Out Of Range: Blower 2 Discharge Pressure
BOOL_OUT[15].3	(T132) Trip: Out Of Range: Blower 2 Discharge Temperature
BOOL_OUT[15].4	(T133) Trip: Out Of Range: Blower 2 Phase A Temperature
BOOL_OUT[15].5	(T134) Trip: Out Of Range: Blower 2 Phase B Temperature
BOOL_OUT[15].6	(T135) Trip: Out Of Range: Blower 2 Phase C Temperature
BOOL_OUT[15].7	(T136) Trip: Out Of Range: Blower 2 ODE Temperature
BOOL_OUT[15].8	(T137) Trip: Out Of Range: Blower 2 DE Temperature
BOOL_OUT[15].9	(T138) Trip: Out Of Range: Blower 2 Motor Amps
BOOL_OUT[15].10	(T139) Trip: Out Of Range: Blower 3 Suction Pressure
BOOL_OUT[15].11	(T140) Trip: Out Of Range: Blower 3 Discharge Pressure
BOOL_OUT[15].12	(T141) Trip: Out Of Range: Blower 3 Discharge Temperature
BOOL_OUT[15].15	(T142) Trip: Out Of Range: Blower 3 Phase A Temperature
BOOL_OUT[15].15	(T143) Trip: Out Of Range: Blower 3 Phase B Temperature
BOOL_OUT[15].15	(T144) Trip: Out Of Range: Blower 3 Phase C Temperature
BOOL_OUT[15].16	(T145) Trip: Out Of Range: Blower 3 ODE Temperature
BOOL_OUT[15].17	(T146) Trip: Out Of Range: Blower 3 DE Temperature
BOOL_OUT[15].18	(T147) Trip: Out Of Range: Blower 3 Motor Amps
BOOL_OUT[15].19	(T148) Trip: Out Of Range: Blower 4 Suction Pressure
BOOL_OUT[15].20	(T149) Trip: Out Of Range: Blower 4 Discharge Pressure
BOOL_OUT[15].21	(T150) Trip: Out Of Range: Blower 4 Discharge Temperature
BOOL_OUT[15].22	(T151) Trip: Out Of Range: Blower 4 Phase A Temperature
BOOL_OUT[15].23	(T152) Trip: Out Of Range: Blower 4 Phase B Temperature

Section 12 • Communications with a Central Controller/DCS

Interface Tag	Description
BOOL_OUT[15].24	(T153) Trip: Out Of Range: Blower 4 Phase C Temperature
BOOL_OUT[15].25	(T154) Trip: Out Of Range: Blower 4 ODE Temperature
BOOL_OUT[15].26	(T155) Trip: Out Of Range: Blower 4 DE Temperature
BOOL_OUT[15].27	(T156) Trip: Out Of Range: Blower 4 Motor Amps
BOOL_OUT[15].28	(T157) Trip: Unassigned
BOOL_OUT[15].29	(T158) Trip: Unassigned
BOOL_OUT[15].30	(T159) Trip: Unassigned
BOOL_OUT[15].31	

Status Data

Blower Status Data is presented in Double Integer Format. To interpret the blower status data, it is necessary to address the specific bits of the Double Integer.

Table 12-5. Status Data

STATUS (Data Type = DINT, Length = 10)	
Interface Tag	Description
BOOL_OUT[21].0	(S001) Status: Blower 1 Stopped
BOOL_OUT[21].1	(S002) Status: Blower 1 Started
BOOL_OUT[21].2	(S003) Status: Blower 2 Stopped
BOOL_OUT[21].3	(S004) Status: Blower 2 Started
BOOL_OUT[21].4	(S005) Status: Blower 3 Stopped
BOOL_OUT[21].5	(S006) Status: Blower 3 Started
BOOL_OUT[21].6	(S007) Status: Blower 4 Stopped
BOOL_OUT[21].7	(S008) Status: Blower 4 Started
BOOL_OUT[21].8	(S009) Status: Blower 1 Anti-Recycle
BOOL_OUT[21].9	(S010) Status: Blower 2 Anti-Recycle
BOOL_OUT[21].10	(S011) Status: Blower 3 Anti-Recycle
BOOL_OUT[21].11	(S012) Status: Blower 4 Anti-Recycle
BOOL_OUT[21].12	(S013) Status: Waiting to Start: Remote Run Permissive Input
BOOL_OUT[21].13	(S014) Status: Waiting to Start: Soft Run Permissive from DCS/Central
BOOL_OUT[21].14	(S015) Status: Not Assigned
BOOL_OUT[21].15	(S016) Status: Loading Inhibited: Low Suction Pressure
BOOL_OUT[21].16	(S017) Status: Loading Inhibited: High Discharge Pressure
BOOL_OUT[21].17	(S018) Status: Not Assigned
BOOL_OUT[21].18	(S019) Status: Forced Unload: Low Suction Pressure
BOOL_OUT[21].19	(S020) Status: Forced Unload: High Discharge Pressure
BOOL_OUT[21].20	(S021) Status: Not Assigned
BOOL_OUT[21].21	(S022) Status: Not Assigned
BOOL_OUT[21].22	(S023) Status: Comms Faulted, Reverted to Local Mode
BOOL_OUT[21].23	(S024) Status: User SUPER Logged In
BOOL_OUT[21].24	(S025) Status: User OP1 Logged In
BOOL_OUT[21].25	(S026) Status: User OP2 Logged In
BOOL_OUT[21].26	(S027) Status: User OP3 Logged In
BOOL_OUT[21].27	(S028) Status: User OP4 Logged In
BOOL_OUT[21].28	(S029) Status: User OP5 Logged In
BOOL_OUT[21].29	(S030) Status: Blower 1 Motor Forced ON
BOOL_OUT[21].30	(S031) Status: Blower 2 Motor Forced ON
BOOL_OUT[21].31	(S032) Status: Blower 3 Motor Forced ON
BOOL_OUT[22].0	(S033) Status: Blower 4 Motor Forced ON

Section 12 • Communications with a Central Controller/DCS

Interface Tag	Description
BOOL_OUT[22].1	(S034) Status: Blower 1 Oil Cooler Forced ON
BOOL_OUT[22].2	(S035) Status: Blower 2 Oil Cooler Forced ON
BOOL_OUT[22].3	(S036) Status: Blower 3 Oil Cooler Forced ON
BOOL_OUT[22].4	(S037) Status: Blower 4 Oil Cooler Forced ON
BOOL_OUT[22].5	(S038) Status: Blower 1 Oil Pump Forced ON
BOOL_OUT[22].6	(S039) Status: Blower 2 Oil Pump Forced ON
BOOL_OUT[22].7	(S040) Status: Blower 3 Oil Pump Forced ON
BOOL_OUT[22].8	(S041) Status: Blower 4 Oil Pump Forced ON
BOOL_OUT[22].9	(S042) Status: Not Assigned
BOOL_OUT[22].10	(S043) Status: Not Assigned
BOOL_OUT[22].11	(S044) Status: Aftercooler 1 VFD FORCED ON
BOOL_OUT[22].12	(S045) Status: Aftercooler 1 Fan 1 FORCED ON
BOOL_OUT[22].13	(S046) Status: Aftercooler 1 Fan 2 FORCED ON
BOOL_OUT[22].14	(S047) Status: Aftercooler 1 Fan 3 FORCED ON
BOOL_OUT[22].15	(S048) Status: Aftercooler 1 Fan 4 FORCED ON
BOOL_OUT[22].16	(S049) Status: Aftercooler 1 Fan 5 FORCED ON
BOOL_OUT[22].17	(S050) Status: Aftercooler 1 Fan 6 FORCED ON
BOOL_OUT[22].18	(S051) Status: Aftercooler 1 Fan 7 FORCED ON
BOOL_OUT[22].19	(S052) Status: Aftercooler 1 Fan 8 FORCED ON
BOOL_OUT[22].20	(S053) Status: Aftercooler 1 Fan 9 FORCED ON
BOOL_OUT[22].21	(S054) Status: Aftercooler 1 Fan 10 FORCED ON
BOOL_OUT[22].22	(S055) Status: Not Assigned
BOOL_OUT[22].23	(S056) Status: Not Assigned
BOOL_OUT[22].24	(S057) Status: Not Assigned
BOOL_OUT[22].25	(S058) Status: Not Assigned
BOOL_OUT[22].26	(S059) Status: Not Assigned
BOOL_OUT[22].27	(S060) Status: Not Assigned
BOOL_OUT[22].28	(S061) Status: Blower 1 Supplemental Shutdown Forced ON
BOOL_OUT[22].29	(S062) Status: Blower 2 Supplemental Shutdown Forced ON
BOOL_OUT[22].30	(S063) Status: Blower 3 Supplemental Shutdown Forced ON
BOOL_OUT[22].31	(S064) Status: Blower 4 Supplemental Shutdown Forced ON
BOOL_OUT[23].0	(S065) Status: Not Assigned
BOOL_OUT[23].1	(S066) Status: Not Assigned
BOOL_OUT[23].2	(S067) Status: Not Assigned
BOOL_OUT[23].3	(S068) Status: Not Assigned
BOOL_OUT[23].4	(S069) Status: Not Assigned
BOOL_OUT[23].5	(S070) Status: Not Assigned
BOOL_OUT[23].6	(S071) Status: Not Assigned
BOOL_OUT[23].7	(S072) Status: Not Assigned
BOOL_OUT[23].8	(S073) Status: Not Assigned
BOOL_OUT[23].9	(S074) Status: Not Assigned

Section 12 • Communications with a Central Controller/DCS

Interface Tag	Description
BOOL_OUT[23].10	(S075) Status: Not Assigned
BOOL_OUT[23].11	(S076) Status: Not Assigned
BOOL_OUT[23].12	(S077) Status: Not Assigned
BOOL_OUT[23].13	(S078) Status: Not Assigned
BOOL_OUT[23].14	(S079) Status: Not Assigned
BOOL_OUT[23].15	(S080) Status: Discharge Recycle Valve FORCED ON
BOOL_OUT[23].16	(S081) Status: Not Assigned
BOOL_OUT[23].17	(S082) Status: Not Assigned
BOOL_OUT[23].18	(S083) Status: Alarm Indication FORCED ON
BOOL_OUT[23].19	(S084) Status: Trip Indication FORCED ON
BOOL_OUT[23].20	(S085) Status: Not Assigned
BOOL_OUT[23].21	(S086) Status: Not Assigned
BOOL_OUT[23].22	(S087) Status: Not Assigned
BOOL_OUT[23].23	(S088) Status: Not Assigned
BOOL_OUT[23].24	(S089) Status: Not Assigned
BOOL_OUT[23].25	(S090) Status: Not Assigned
BOOL_OUT[23].26	(S091) Status: Inlet Scrubber Drain Pump Forced ON
BOOL_OUT[23].27	(S092) Status: Inlet Scrubber Drain Solenoid Forced ON
BOOL_OUT[23].28	(S093) Status: Outlet Scrubber Drain Pump Forced ON
BOOL_OUT[23].29	(S094) Status: Outlet Scrubber Drain Solenoid Forced ON
BOOL_OUT[23].30	(S095) Status: Not Assigned
BOOL_OUT[23].31	(S096) Status: Not Assigned
BOOL_OUT[24].0	(S097) Status: Not Assigned
BOOL_OUT[24].1	(S098) Status: Not Assigned
BOOL_OUT[24].2	(S099) Status: Not Assigned
BOOL_OUT[24].3	(S100) Status: Not Assigned
BOOL_OUT[24].4	(S101) Status: Not Assigned
BOOL_OUT[24].5	(S102) Status: Not Assigned
BOOL_OUT[24].6	(S103) Status: Not Assigned
BOOL_OUT[24].7	(S104) Status: INLET SCRUBBER - PUMP 2 FORCED ON
BOOL_OUT[24].8	(S105) Status: OUTLET SCRUBBER - PUMP 2 FORCED ON
BOOL_OUT[24].9	(S106) Status: Not Assigned
BOOL_OUT[24].10	(S107) Status: Not Assigned
BOOL_OUT[24].11	(S108) Status: Not Assigned
BOOL_OUT[24].12	(S109) Status: User MGR Logged In
BOOL_OUT[24].13	(S110) Status: Not Assigned
BOOL_OUT[24].14	(S111) Status: Not Assigned
BOOL_OUT[24].15	(S112) Status: Not Assigned
BOOL_OUT[24].16	(S113) Status: Aftercooler 1 Valve Forced
BOOL_OUT[24].17	(S114) Status: Not Assigned
BOOL_OUT[24].18	(S115) Status: Not Assigned

Section 12 • Communications with a Central Controller/DCS

Interface Tag	Description
BOOL_OUT[24].19	(S116) Status: Not Assigned
BOOL_OUT[24].20	(S117) Status: Not Assigned
BOOL_OUT[24].21	(S118) Status: Rung Edit Detected
BOOL_OUT[24].22	(S119) Status: Not Assigned
BOOL_OUT[24].23	(S120) Status: Not Assigned
BOOL_OUT[24].24	(S121) Status: Not Assigned
BOOL_OUT[24].25	(S122) Status: Not Assigned

States of Discrete I/O

States of the Discrete Inputs and Outputs is presented in Double Integer Format. To interpret the IO State data, it is necessary to address the specific bits of the Double Integer.

Table 12-6. Discrete Input

Discrete Input States (Data Type = DINT)	
Interface Tag	Description
BOOL_OUT[31].0	Aftercooler 1 Fan Aux Contact (Step Type)
BOOL_OUT[31].1	Aftercooler 1 Fan Aux Contact (Step Type)
BOOL_OUT[31].2	Aftercooler 1 Fan Aux Contact (Step Type)
BOOL_OUT[31].3	Aftercooler 1 Fan Aux Contact (Step Type)
BOOL_OUT[31].4	Aftercooler 1 Fan Aux Contact (Step Type)
BOOL_OUT[31].5	Aftercooler 1 Fan Aux Contact (Step Type)
BOOL_OUT[31].6	Aftercooler 1 Fan Aux Contact (Step Type)
BOOL_OUT[31].7	Aftercooler 1 Fan Aux Contact (Step Type)
BOOL_OUT[31].8	Aftercooler 1 Fan Aux Contact (Step Type)
BOOL_OUT[31].9	Aftercooler 1 Fan Aux Contact (Step Type)
BOOL_OUT[31].10	Aftercooler 1 VFD Faulted (VFD Type)
BOOL_OUT[31].11	Aftercooler 1 VFD Running
BOOL_OUT[31].12	Blower 1 Oil Pressure Switch (1=OK)
BOOL_OUT[31].13	Blower 1 Oil Cooler Fan Running
BOOL_OUT[31].14	Blower 1 Oil Pump Running
BOOL_OUT[31].15	Blower 1 VFD Faulted (0=Faulted)
BOOL_OUT[31].16	Blower 1 VFD Running
BOOL_OUT[31].17	Blower 2 Oil Pressure Switch (1=OK)
BOOL_OUT[31].18	Blower 2 Oil Cooler Fan Running
BOOL_OUT[31].19	Blower 2 Oil Pump Running
BOOL_OUT[31].20	Blower 2 VFD Faulted (0=Faulted)
BOOL_OUT[31].21	Blower 2 VFD Running
BOOL_OUT[31].22	Blower 3 Oil Pressure Switch (1=OK)
BOOL_OUT[31].23	Blower 3 Oil Cooler Fan Running
BOOL_OUT[31].24	Blower 3 Oil Pump Running
BOOL_OUT[31].25	Blower 3 VFD Faulted (0=Faulted)
BOOL_OUT[31].26	Blower 3 VFD Running
BOOL_OUT[31].27	Blower 4 Oil Pressure Switch (1=OK)
BOOL_OUT[31].28	Blower 4 Oil Cooler Fan Running
BOOL_OUT[31].29	Blower 4 Oil Pump Running
BOOL_OUT[31].30	Blower 4 VFD Faulted (0=Faulted)
BOOL_OUT[31].31	Blower 4 VFD Running
BOOL_OUT[32].0	E-stop OK and MCR energized

Section 12 • Communications with a Central Controller/DCS

Interface Tag	Description
BOOL_OUT[32].1	Lower Inlet Scrubber High Alarm (Coalescing)
BOOL_OUT[32].2	Lower Inlet Scrubber High Trip (Coalescing)
BOOL_OUT[32].3	Upper Inlet Scrubber High Alarm (Coalescing)
BOOL_OUT[32].4	Upper Inlet Scrubber High Trip (Coalescing)
BOOL_OUT[32].5	Inlet Scrubber Condensate Drain Cutin Switch
BOOL_OUT[32].6	Inlet Scrubber Condensate Drain Cutout Switch
BOOL_OUT[32].7	Inlet Scrubber High Alarm (Vane type)
BOOL_OUT[32].8	Inlet Scrubber High Trip (Vane Type)
BOOL_OUT[32].9	Inlet Scrubber Low Level (Vane Type)
BOOL_OUT[32].10	Inlet Scrubber Condensate Pump Aux Contact
BOOL_OUT[32].11	Inlet Scrubber Condensate Pump Aux Contact
BOOL_OUT[32].12	Lower Outlet Scrubber High Alarm (Coalescing)
BOOL_OUT[32].13	Lower Outlet Scrubber High Trip (Coalescing)
BOOL_OUT[32].14	Upper Outlet Scrubber High Alarm (Coalescing)
BOOL_OUT[32].15	Upper Outlet Scrubber High Trip (Coalescing)
BOOL_OUT[32].16	Outlet Scrubber Condensate Drain Cutin Switch
BOOL_OUT[32].17	Outlet Scrubber Condensate Drain Cutout Switch
BOOL_OUT[32].18	Outlet Scrubber High Alarm (Vane type)
BOOL_OUT[32].19	Outlet Scrubber High Trip (Vane Type)
BOOL_OUT[32].20	Outlet Scrubber Low Level (Vane Type)
BOOL_OUT[32].21	Outlet Scrubber Condensate Pump Aux Contact
BOOL_OUT[32].22	Outlet Scrubber Condensate Pump Aux Contact
BOOL_OUT[32].23	User Defined Alarm Input 1
BOOL_OUT[32].24	User Defined Alarm Input 2
BOOL_OUT[32].25	User Defined Alarm Input 3
BOOL_OUT[32].26	User Defined Alarm Input 4
BOOL_OUT[32].27	User Defined Alarm Input 5
BOOL_OUT[32].28	Remote Permissive hardwired input
BOOL_OUT[32].29	User Defined Trip Input 1
BOOL_OUT[32].30	User Defined Trip Input 2
BOOL_OUT[32].31	User Defined Trip Input 3
BOOL_OUT[33].0	User Defined Trip Input 4
BOOL_OUT[33].1	User Defined Trip Input 5
BOOL_OUT[33].2	Oil Cooler VFD Faulted (VFD Type)
BOOL_OUT[33].3	Oil Cooler VFD Running
BOOL_OUT[33].4	Oil Recovery Enable Switch
BOOL_OUT[33].5	Oil Separator Low Level Switch
BOOL_OUT[33].6	Outlet Scrubber Condensate Pump Aux Contact
BOOL_OUT[33].7	Outlet Scrubber Condensate Pump Aux Contact
BOOL_OUT[33].8	Lower Outlet Scrubber High Alarm (Coalescing)
BOOL_OUT[33].9	Lower Outlet Scrubber High Trip (Coalescing)

Section 12 • Communications with a Central Controller/DCS

Interface Tag	Description
BOOL_OUT[33].10	Upper Outlet Scrubber High Alarm (Coalescing)
BOOL_OUT[33].11	Upper Outlet Scrubber High Trip (Coalescing)
BOOL_OUT[33].12	Outlet Scrubber Condensate Drain Cutin Switch
BOOL_OUT[33].13	Outlet Scrubber Condensate Drain Cutout Switch
BOOL_OUT[33].14	Outlet Scrubber High Alarm (Vane type)
BOOL_OUT[33].15	Outlet Scrubber High Trip (Vane Type)
BOOL_OUT[33].16	Outlet Scrubber Low Level (Vane Type)
BOOL_OUT[33].17	User Defined Alarm Input 1
BOOL_OUT[33].18	User Defined Alarm Input 2
BOOL_OUT[33].19	User Defined Alarm Input 3
BOOL_OUT[33].20	User Defined Alarm Input 4
BOOL_OUT[33].21	User Defined Alarm Input 5
BOOL_OUT[33].22	Remote Manual Capacity Decrease Input
BOOL_OUT[33].23	Remote Manual Capacity Increase Input
BOOL_OUT[33].24	Remote Permissive hardwired input
BOOL_OUT[33].25	User Defined Trip Input 1
BOOL_OUT[33].26	User Defined Trip Input 2
BOOL_OUT[33].27	User Defined Trip Input 3
BOOL_OUT[33].28	User Defined Trip Input 4
BOOL_OUT[33].29	User Defined Trip Input 5
BOOL_OUT[33].30	Smoke Detector Input
BOOL_OUT[33].31	

Table 12-7. Discrete Output

Discrete Output States (Data Type = DINT)	
Interface Tag	Description
BOOL_OUT[36].0	Aftercooler 1 Fan Starter (Step Type)
BOOL_OUT[36].1	Aftercooler 1 Fan Starter (Step Type)
BOOL_OUT[36].2	Aftercooler 1 Fan Starter (Step Type)
BOOL_OUT[36].3	Aftercooler 1 Fan Starter (Step Type)
BOOL_OUT[36].4	Aftercooler 1 Fan Starter (Step Type)
BOOL_OUT[36].5	Aftercooler 1 Fan Starter (Step Type)
BOOL_OUT[36].6	Aftercooler 1 Fan Starter (Step Type)
BOOL_OUT[36].7	Aftercooler 1 Fan Starter (Step Type)
BOOL_OUT[36].8	Aftercooler 1 Fan Starter (Step Type)
BOOL_OUT[36].9	Aftercooler 1 Fan Starter (Step Type)
BOOL_OUT[36].10	Aftercooler 1 Fan Starter (Step Type)
BOOL_OUT[36].11	Aftercooler 1 VFD Start Command
BOOL_OUT[36].12	Alarm Indication (0=ALARM)
BOOL_OUT[36].13	Blower 1 Shunt Trip Output

Section 12 • Communications with a Central Controller/DCS

Interface Tag	Description
BOOL_OUT[36].14	Blower 1 VFD Start Output
BOOL_OUT[36].15	Blower 2 Shunt Trip Output
BOOL_OUT[36].16	Blower 2 VFD Start Output
BOOL_OUT[36].17	Blower 3 Shunt Trip Output
BOOL_OUT[36].18	Blower 3 VFD Start Output
BOOL_OUT[36].19	Blower 4 Shunt Trip Output
BOOL_OUT[36].20	Blower 4 VFD Start Output
BOOL_OUT[36].21	Discharge Recycle Valve Air Solenoid
BOOL_OUT[36].22	Inlet Scrubber Backup Drain Solenoid
BOOL_OUT[36].23	Inlet Scrubber Condensate Pump Starter
BOOL_OUT[36].24	Inlet Scrubber Condensate Pump Starter (or SV)
BOOL_OUT[36].25	Outlet Scrubber Backup Drain Solenoid
BOOL_OUT[36].26	Outlet Scrubber Condensate Pump Starter
BOOL_OUT[36].27	Outlet Scrubber Condensate Pump Starter (or SV)
BOOL_OUT[36].28	Trip Indication (0=TRIP)

Blower State Indicator

The state of the blower state indicator shown on the blower and system overview screens can be monitored.

Table 12-8. State Indicator

State Indicator (Data Type = DINT, Length = 1)	
Tag	Description
BLWR_STATE_IND[1]	BLOWER 1 State Indicator
BLWR_STATE_IND[2]	BLOWER 2 State Indicator
BLWR_STATE_IND[3]	BLOWER 3 State Indicator
BLWR_STATE_IND[4]	BLOWER 4 State Indicator
State	Description
0	Out of Service
1	Stopped
2	Anti-Recycle
3	Disabled
4	Standby
5	Running

Data that can be Written to the Blower PLC

To send commands to the Blower PLC, Control by Communications must be enabled from the Configuration screen and the watchdog must show that communications between the Blower PLC and Central Controller/DCS are not faulted. On a communication fault, the commands from the Central controller will stay in their last state/value in the blower PLC.

Table 12-9. Blower Command (Real)

Blower Commands: "REAL_IN" (Data Type = REAL)		
Interface Tag	Description	Units
REAL_IN[0]	Remote Discharge Pressure Setpoint	PSIA
REAL_IN[1]		
REAL_IN[2]	Remote Suction Pressure Setpoint	PSIA
REAL_IN[3]	Common Discharge Header Pressure From DCS	PSIA
REAL_IN[4]	Common Suction Header Pressure From DCS	PSIA
REAL_IN[5]	Blower 1 Remote Manual Speed	% Speed
REAL_IN[6]	Blower 2 Remote Manual Speed	% Speed
REAL_IN[7]	Blower 3 Remote Manual Speed	% Speed
REAL_IN[8]	Blower 4 Remote Manual Speed	% Speed

DISCRETE BLOWER COMMANDS

Discrete Blower commands are presented in Double Integer Format. To send discrete commands, it is necessary to address the specific bits of the Double Integer.

Configuration Screen, the soft run command (BOOL_IN[1].5) must be held HIGH in addition to the remote permissive physical input.

If Control by communications is enabled from the

Table 12-10. Blower Command (Double Integer)

Write Data: "BOOL_IN" (Data Type = DINT)	
Interface Tag	Description
BOOL_IN[1].0	
BOOL_IN[1].1	Blower 1 Remote Enable (1=Enable)
BOOL_IN[1].2	Blower 2 Remote Enable (1=Enable)
BOOL_IN[1].3	Blower 3 Remote Enable (1=Enable)
BOOL_IN[1].4	Blower 4 Remote Enable (1=Enable)
BOOL_IN[1].5	
BOOL_IN[1].6	Local Mode Command from DCS
BOOL_IN[1].7	Remote Mode Command from DCS
BOOL_IN[1].8	Reset Alarms from DCS
BOOL_IN[1].9	Soft Run Command from DCS

EmersonClimate.com