

Copeland™ CR Series

For Medium & High Temperature Applications
- R407C



COPELAND™

EMERSON™



About Emerson

Emerson is a global technology and engineering company providing innovative solutions for customers in industrial, commercial, and residential markets. Our Emerson Automation Solutions business helps process, hybrid, and discrete manufacturers maximize production, protect personnel and the environment while optimizing their energy and operating costs. Our Emerson Commercial and Residential Solutions business helps ensure human comfort and health, protect food quality and safety, advance energy efficiency, and create sustainable infrastructure.

Emerson Commercial and Residential Solutions India provides advanced compressors, condensing units, flow control systems and electronic controls to protect food quality while enabling operators to maximize equipment uptime and increase energy efficiency.

CR Series Compressors

Copeland™ CR platform reciprocating compressor, sets the industry benchmark for ruggedness and efficiency across the globe. Different series of CR models evolved over a period of time, like CR6, CR7, CRKQ, etc. to meet the continuously evolving customer requirements and market needs.

Living up to its status of thought-leader and innovator to the industry, Emerson has developed the next generation CR Series Compressors which utilize R407C refrigerant. These new CRK6ME & CRKQME reciprocating models provide customers with the opportunity to switch from R22 refrigerant to R407C refrigerant. These compressors are available with POE oil which allows oil and refrigerant to mix well, and provides ideal oil return back to the compressor. These highly efficient, silent and reliable CR compressors make them the best-in-class available models in the market.

These compressors deliver superior performance, have a wide operating range, offer multiple electrical options and come with a host of other features.

CRKXME Models Nomenclature

Digit	Heater
1	No Heater
2	1 Ph Heater
3	3 Ph Heater

Digit	Suction	Discharge	Process
0	Tube Upward	Tube	Tube Upward
1	Tube Angular	Tube	Tube Upward
2	Tube Angular	Tube	Other
3	Spud	Spud	Upward

Digit	Mounting	Mounting Kit	Terminal Fence
1	Long Leg	Standard	Standard
2	Long Leg	Standard	Rectangular

Typical Electrical Codes		
Code	50 Hz	60 Hz
"V"		208-230 V
"Z"	220-240 V	
"D"	380-420 V	380-460 V
"M"	380-420 V	
"5"		208-230 V
"1"	230 V	

Motor Protection Type	
"F"	Internal Protection use with Single or Three Phase Contactor

Motor Type	
"P"	Single Phase Permanent Split Capacitor
"T"	Three Phase

C R 2 4 K 6 M E - P F V - 1 0 1

Bill of Material (BOM) Suffix

Oil Type	
"Blank"	Mineral Oil (R22)
"E"	POE Oil (R407C)

Identifier	
"M"	Optimized Design

Product Family Variations	
"6, 7, 8"	CR
"Q"	CR Large

Capacity	
XX	First two digits of nominal capacity Btu/h @ 60 Hz
"K"	x1,000 multiplier

Compressor Family Series	
"CR"	CR Series Compressor

Mounting Kit Nomenclature

Standard Standard Mounting Kit & Fence Design
 Other Indicates Non Standard Requirements-
 suffixed by two digits

Terminal Fence Nomenclature

Standard Half Round for CR21/29TFM
 Half Round for CR22/30PF1
 Square for CR35/41TFM
 Square for CR36/42PFZ
 Rectangle for CR47/53/57/62TFD

Series	Compressor Model	Voltage Rating (V-Phase-Hz)	Cooling Capacity (Btu/hr)	Input Power (Watts)	EER (Btu/W-Hr)	Input Current (A)	LRA(A)	Displacement (cc/Rev.)	Weight (Approx.)	Motor Circuit	Start Capacitor Mfd	Start Capacitor VAC	Run Capacitor Mfd	Run Capacitor VAC	Standard BOM
CRK6ME	CR22K6ME-PF1	230V -1Ph -50Hz	16650	1700	9.79	7.90	54	40.8	33.1	PSC/CSCR	80-100	230	36	440	111DM
	CR30K6ME-PF1	230V -1Ph -50Hz	23500	2280	10.30	10.30	72	51.47	33.1	PSC/CSCR	150-200	230	45	440	111DE 111DM
	CR36K6ME-PFZ	220 to 240V - 1Ph - 50Hz	27400	2715	10.09	13.40	85	59.65	36	CSCR	130-156 43-52	250 330	40 45	370 370	121DM
	CR42K6ME-PFZ	220 to 240V - 1Ph - 50Hz	32350	3100	10.43	15	104	72.08	36	CSCR	64-77 189-227	330 330	60 65	370 370	101DM
	CR21K6ME-TFM	380 to 480V - 3 Ph - 50Hz	17250	1610	10.71	3.20	20	40.8	30	3 Phase	N/A	N/A	N/A	N/A	111DM
	CR29K6ME-TFM	380 to 480V - 3 Ph - 50Hz	24200	2260	10.70	4.15	28	51.47	30.6	3 Phase	N/A	N/A	N/A	N/A	111DM
	CR35K6ME-TFM	380 to 420V - 3Ph - 50Hz	29350	2650	11.07	4.80	41	59.66	32.1	3 Phase	N/A	N/A	N/A	N/A	121DM
	CR41K6ME-TFM	380 to 420V - 3Ph - 50Hz	33160	3070	10.80	5.90	45	72.09	34	3 Phase	N/A	N/A	N/A	N/A	101DM
CRKQME	CR47KQME-TFD	380 to 420V - 3Ph - 50Hz	37595	3580	10.50	6.90	60 @ 420 66 @ 480	78.78	37.5	3 Phase	N/A	N/A	N/A	N/A	203DM 233DM
	CR53KQME-TFD	380 to 420V - 3Ph - 50Hz	42436	4110	10.32	7.60	61 @ 420	88.28	37.5	3 Phase	N/A	N/A	N/A	N/A	203DM 233DM
	CR57KQME-TFD	380 to 420V - 3Ph - 50Hz	46350	4450	10.41	8.20	61 @ 420	94.61	37.5	3 Phase	N/A	N/A	N/A	N/A	203DM 233DM
	CR62KQME-TFD	380 to 420V - 3Ph - 50Hz	50985	4890	10.42	8.90	55 @ 420 65 @ 480	101.92	37.5	3 Phase	N/A	N/A	N/A	N/A	203DM 233DM

ASRE/T Rating Conditions

Rating Conditions	Evaporating Temperature °C(F)	Condensing Temperature °C(F)	Ambient Temperature °C(F)	Liquid Temperature °C(F)	Return Gas Temperature °C(F)
ASRE/T	7.2(45)	54.4(130)	35(95)	46(115)	35(95)

Motor Circuit

PSC	Permanent Split Capacitor
CSCR	Capacitor Start Capacitor Run

Notes: • Cooling capacity and power consumption are nominal values at specified rating conditions and subject to ± 5% variation.
• Cooling type(CFM)-400 • Oil charge quantity-1330cc (Approx.)

Product Range

R407C - 50Hz

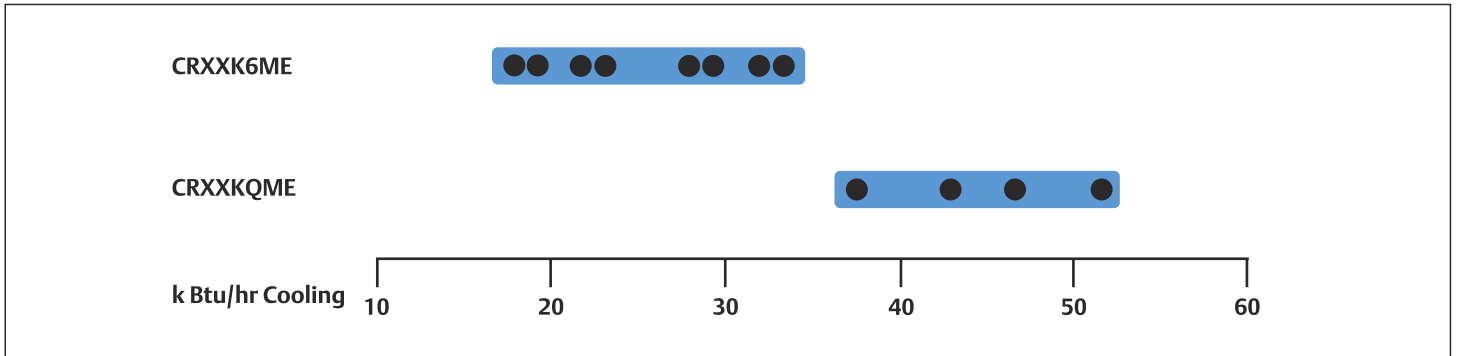

Notes: The above capacity data are given at the following conditions.
Ambient Temperature: 35°C, Evaporating Temperature: 7.2°C, Return Gas Temperature: 35°C, Condensing Temperature: 54.4°C

Wiring Diagram

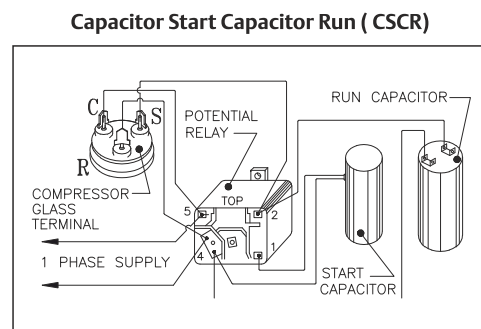
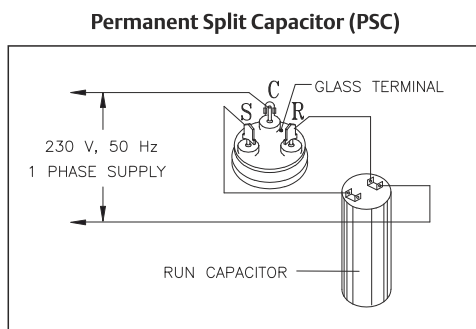

Performance Data - R407C, 50Hz, 1Ph

Compressor Models	Condensing Temperature (°C)	Refrigeration Capacity in (Btu/hr)								
		Evaporating Temperature (°C)								
		-23.3	-17.8	-12.2	-6.7	-1.1	4.4	7.2	10	12.8
CR22K6ME-PF1	43.3	-	4350	7300	10500	14000	18150	20500	23000	25800
	54.4	-	-	5200	8100	11200	14700	16650	18850	21200
CR30K6ME-PF1	43.3	-	6824	10393	14650	19600	25200	28300	31500	34900
	54.4	-	-	7227	11200	15700	20750	23500	26400	29500
CR36K6ME-PFZ	43.3	-	7100	11400	16500	22600	29900	34100	38700	43700
	54.4	-	-	8200	12400	17500	23772	27400	31425	35850
CR42K6ME-PFZ	43.3	-	8300	13450	19500	26650	35300	40250	45650	51600
	54.4	-	-	9600	14600	20650	28050	32350	37100	42325

Performance Data - R407C, 50Hz, 3Ph

Compressor Models	Condensing Temperature (°C)	Refrigeration Capacity in (Btu/hr)								
		Evaporating Temperature (°C)								
		-23.3	-17.8	-12.2	-6.7	-1.1	4.4	7.2	10	12.8
CR21K6ME-TFM	43.3	-	4900	7900	11970	14500	18750	21300	24100	27300
	54.4	-	-	5400	8300	11400	15100	17250	19600	22300
CR29K6ME-TFM	43.3	-	6900	10750	15200	20300	26050	29200	32500	36050
	54.4	-	-	7500	11550	16150	21300	24200	27100	30300
CR35K6ME-TFM	43.3	-	7600	12200	17650	24175	32000	36500	41400	46750
	54.4	-	-	8800	13250	18725	25450	29350	33625	38350
CR41K6ME-TFM	43.3	-	8500	13800	20000	27400	36250	41300	46900	52950
	54.4	-	-	9900	15000	21200	28800	33200	38100	43450
CR47KQME-TFD	43.3	-	9600	15750	22825	31200	41150	46850	53050	59825
	54.4	-	-	10725	16825	24000	32600	37400	42925	48850
CR53KQME-TFD	43.3	-	10700	17600	25565	34975	46140	52500	59450	67025
	54.4	-	-	12040	18900	26975	36620	42200	48175	54800
CR57KQME-TFD	43.3	-	11700	19250	27975	38250	50500	57450	65050	73300
	54.4	-	-	13175	20675	29500	40050	46100	52700	59950
CR62KQME-TFD	43.3	-	12900	21200	30750	42050	55500	63125	71488	80600
	54.4	-	-	14450	22700	32450	44050	50700	57950	65900

Operating Envelopes

CR22K6ME-PF1, CR30K6ME-PF1, CR35K6ME-TFM, CR47KQME-TFD, CR53KQME-TFD, CR57KQME-TFD, CR62KQME-TFD

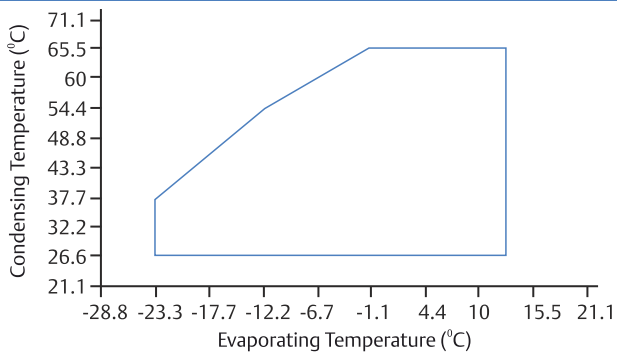

CR41K6ME-TFM

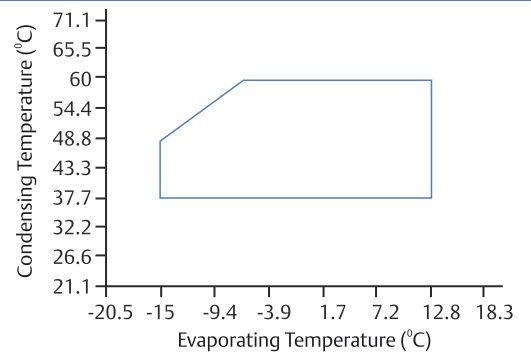

CR36K6ME-PFZ, CR42K6ME-PFZ, CR21K6ME-TFM, CR29K6ME-TFM,

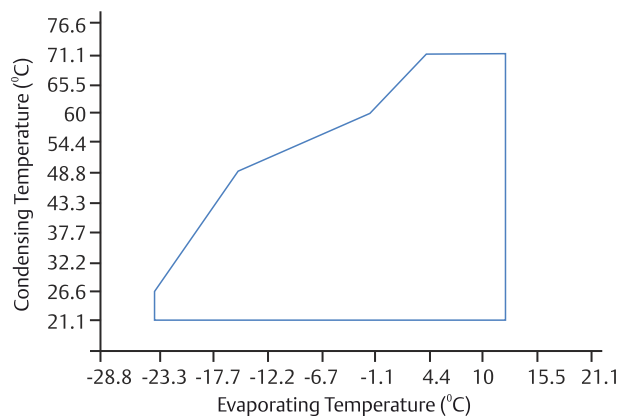

R407C Models

Compressor Model	View	Mount Type	Dist 'A'	Suction Tube ID		Discharge Tube ID	
			inch	inch	mm	inch	mm
CR22K6ME-PF1-111DM	P	Square	14.22	0.507	12.88	0.382	9.7
CR30K6ME-PF1-111DM/DE	P		14.22	0.632	16.05	0.382	9.7
CR36K6ME-PFZ-121DM	S		14.63	0.632	16.05	0.382	9.7
CR42K6ME-PFZ-101DM	T		15.13	0.758	19.25	0.382	9.7
CR21K6ME-TFM-111DM	P		14.46	0.507	12.88	0.382	9.7
CR29K6ME-TFM-111DM	P		14.46	0.632	16.05	0.382	9.7
CR35K6ME-TFM-121DM	S		14.38	0.632	16.05	0.382	9.7
CR41K6ME-TFM-101DM	T		14.88	0.758	19.25	0.382	9.7

Large CRs (with Suction & Discharge Tube)

Compressor Model	View	Mount Type	Dist 'A'	Suction Tube ID		Discharge Tube ID		Process Tube ID	
			inch	inch	mm	inch	mm	inch	mm
CR47KQME-TFD-203DM	Q	Square	15.51	0.883	22.43	0.508	12.9	0.383	9.7
CR53KQME-TFD-203DM	Q		15.51	0.883	22.43	0.508	12.9	0.383	9.7
CR57KQME-TFD-203DM	Q		15.51	0.883	22.43	0.508	12.9	0.383	9.7
CR62KQME-TFD-203DM	Q		15.51	0.883	22.43	0.508	12.9	0.383	9.7

Large CRs (with Suction & Discharge Spud)

Compressor Model	View	Mount Type	Dist 'A'	Suction Spud Dimensions	Discharge Spud Dimensions	Process Tube ID	
			inch	inch	inch	inch	mm
CR47KQME-TFD-233DM	R	Square	15.51	1 1/4	1	0.383	9.7
CR53KQME-TFD-233DM	R		15.51	1 1/4	1	0.383	9.7
CR57KQME-TFD-233DM	R		15.51	1 1/4	1	0.383	9.7
CR62KQME-TFD-233DM	R		15.51	1 1/4	1	0.383	9.7



View R - Square Mount with Suction & Discharge Spud

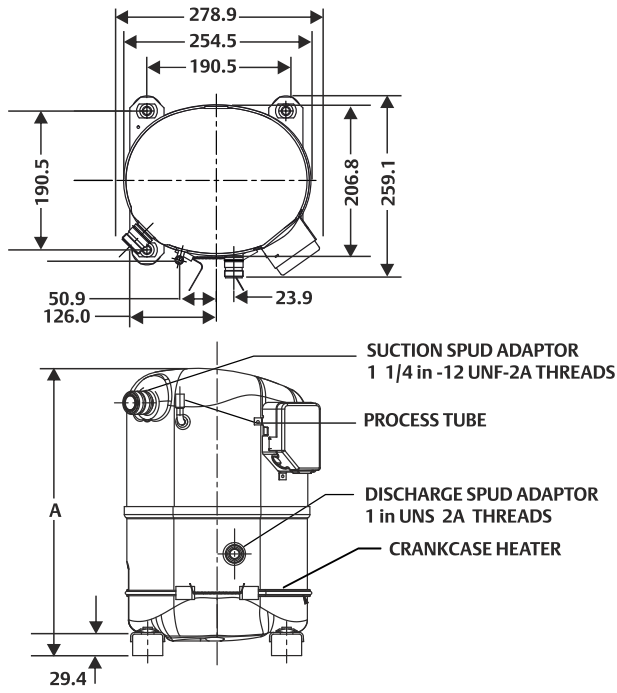

View P - Square Mount

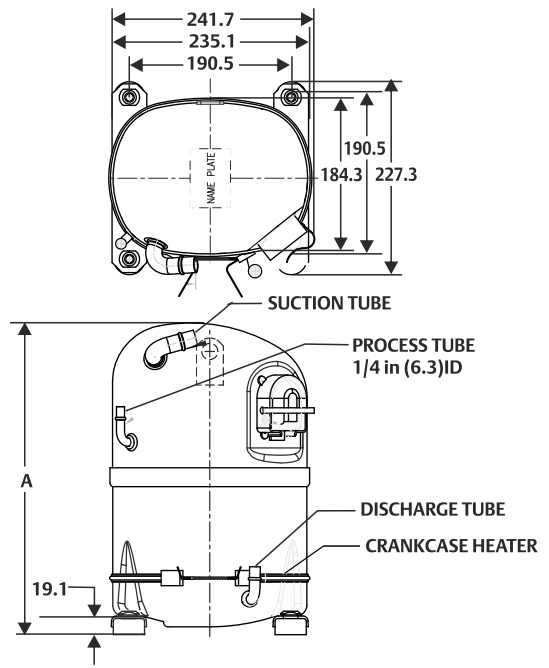

View Q - Square Mount

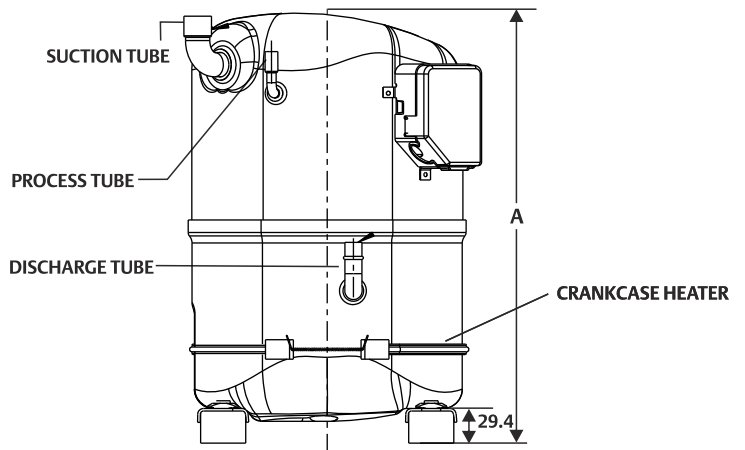
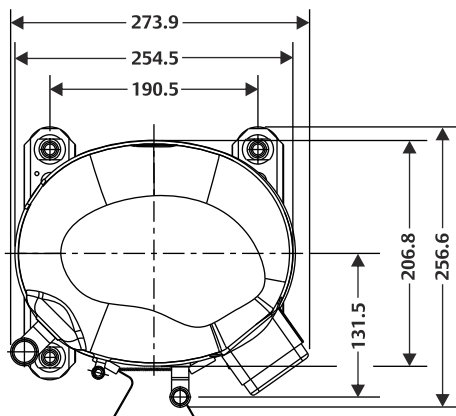

View S - Square Mount with Suction & Discharge Tube

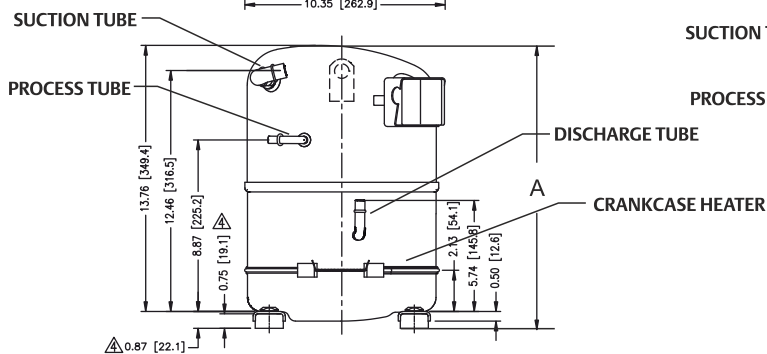
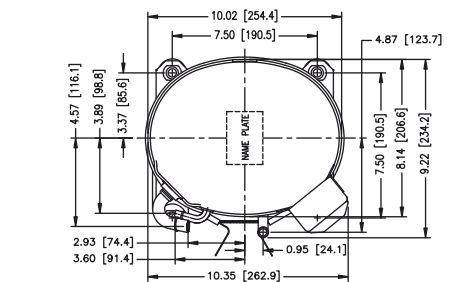

View T - Square Mount

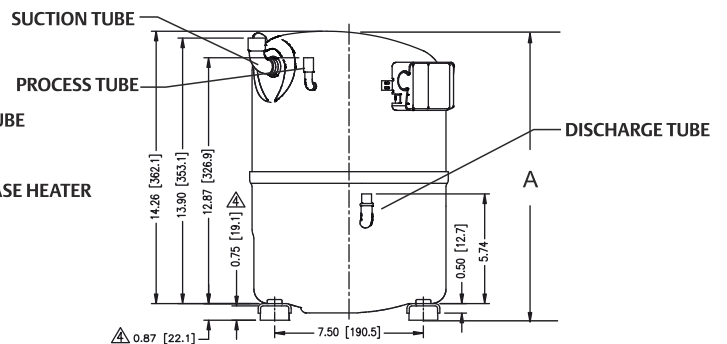
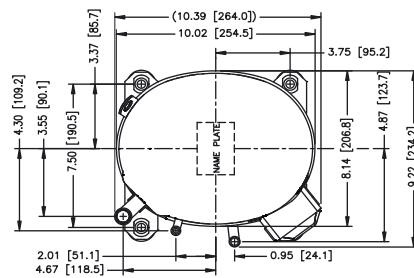

Note : All dimensions are in mm

SALES OFFICES:

Gurgaon

Emerson Climate Technologies (India) Pvt. Ltd.
18th Floor, Towers B & C,
DLF Cyber Terraces, DLF Building No. 5,
DLF Cyber City, Phase –III,
Gurgaon-122002
Tel: (91-124) 4894 500

Mumbai

Emerson Climate Technologies (India) Pvt. Ltd.
Delphi B-Wing, 601-602,
6th Floor, Central Avenue,
Hiranandani Business Park, Powai,
Mumbai- 400076
Tel: (91-22) 6662 0566

Secunderabad

Emerson Climate Technologies (India) Pvt. Ltd.
C/o Maruthi Corporate Point,
Swapnalok Complex 2nd Floor, Block -B ,
Sarojinidevi Road, Secunderabad-500003
Tel: (91-40) 3315 4018

Disclaimer

Technical data given was correct at the time of printing. Updates may occur, and should you need confirmation of a specific value, please contact Emerson stating clearly the information required. Emerson cannot be held responsible for errors in capacities, dimensions, etc., stated herein. Products, specifications and data in this literature are subject to change without notice. The information given herein is based on data and tests which Emerson believes to be reliable and which are in accordance with today's technical knowledge. It is intended for use by persons having the appropriate technical knowledge and skill, at their own discretion and risk. The products given here are designed and adapted for stationary applications only. For transport applications, Please consult with your Emerson representative.

Note

The components listed in this catalogue are not released for use with caustic, poisonous or flammable substances. Emerson cannot be held responsible for any damage caused by using these substances.

Emerson Climate Technologies (India) Pvt. Ltd.

Registered Head Office
Plot No. 23, Rajiv Gandhi Infotech Park, Phase II,
Hinjewadi, Pune - 411 507
Tel: (91-20) 4200 2000, Fax: (91-20) 4200 2099

www.Climate.Emerson.com/Asia

☎ 1800 209 1700 ✉ ClimateIndia@Emerson.com

Scan to download
the soft copy



Emerson and Copeland are trademarks of Emerson Electric Co. or one of its affiliated companies. ©2019
Emerson Climate Technologies (India) Private Limited. All rights reserved.

  @EmersonComResAP

ASIA10B0303R12219

EMERSON. CONSIDER IT SOLVED.