

**COPELAND**

21V51D-751 two-stage  
integrated furnace control

**COPELAND**

# Business and product overview

21V51D-751 two-stage integrated furnace control



# Introduction

The 21V51D-751 expands White-Rodgers' carrier & ICP family product offerings

**Integrated furnace control**

**D**  
OEM Direct

**21V51D-751**  
Carrier/ICP

Two-stage applications  
PSC/VS or EMCx blower motors  
120V HSI ignition

One board for all carrier/ICP blower motor types

**WHITE RODGERS**  
by COPELAND

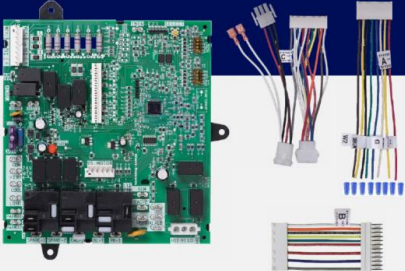

Provides an additional SKU for:



# Extensive carrier/ICP offerings

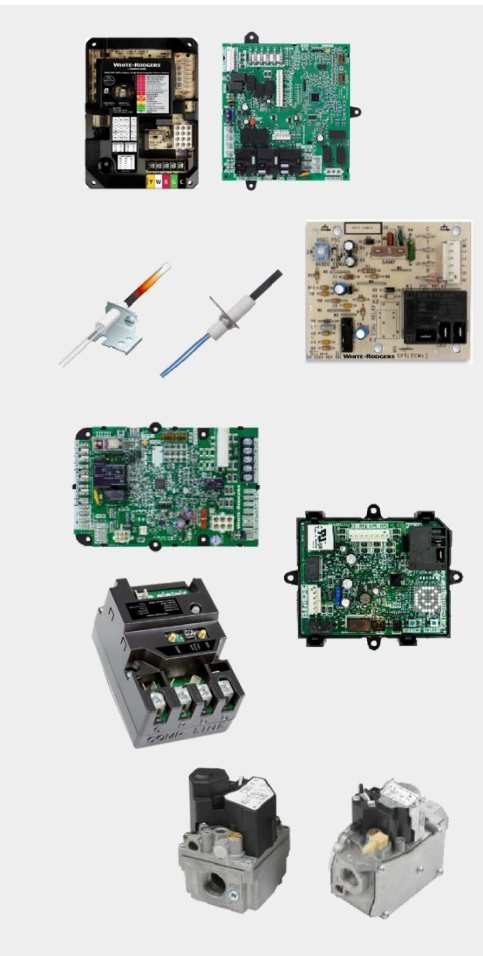

	MODEL NUMBERS	REPLACES
<b>Integrated furnace controls single &amp; 2-stage</b>	50M56U-751 21V51D-751	<b>HK42FZ</b> 004, 005, 007, 008, 009, 010, 011, 013, 015, 016, 017, 019, 020, 028, 034, 040, 041
<b>Air handler controls</b>	48M55-751 48P55-751	<b>HK61EA</b> 002, 006, 010 1171734, 1172975
<b>Ignitors, nitride &amp; carbide</b>	767A-370	<b>LH33ZS</b> 001, 002, 003, 004
	789A-751A1	LH33ZG001
	789A-751KT1/KT2	331930-751, 332505-751
<b>Flame sensor</b>	790-751A1 <i>(Available August 2020)</i>	<b>LH33WZ</b> 511, 515, 517
		LH680012, LH680014
		LH33WZ521
<b>Fan Timer – universal</b>	50F06-843	ST9120, ST9160 ICP brand intelligent valve systems
<b>Defrost control – universal</b>	47D01U-843	CES01 10063, CES0130024 & 76 HK32EA series 1052757, 1069364, 1087952 & 53, 1093410, and many more
<b>SureSwitch – universal contactor</b>	49P11-843	250+ parts replaced
<b>Gas valves</b>	36C03-333 36H32-423 36H33-412 36H64-463 36J22-214 36J54-214 36J24-214	1000+ parts replaced

# One SKU replaces 20 carrier/ICP part numbers

The 21V51D-751 kit includes all an installer needs for:

- Two-stage applications
- PSC/VS or ECMx blower motors
- 120V HSI ignition

## Integrated furnace control

**D**  
OEM Direct

**21V51D-751**  
Carrier/ICP

*Two-stage applications*

*PSC/VS or EMCx  
blower motors*

*120V HSI ignition*

*One board for  
all carrier/ICP  
blower motor types*

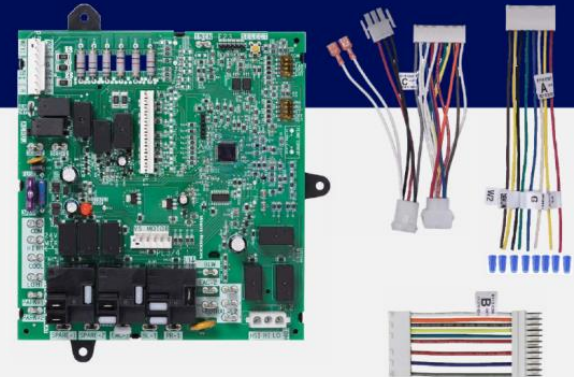

1-Year Limited Warranty

**WHITE RODGERS**  
by COPELAND



# 21V51D-751 overview

First of its kind to replace PSC, variable speed and ECMx applications

## Reduces stocking SKUs

- One SKU replaces several OEM and competitive models

## Advance diagnostics for servicing

- Tri-color LED shows operational status and fault codes
- Simple push-button to retrieve fault codes

## Premium home comfort

- Continuous low-speed fan option for better temperature balance and full-time air cleaning
- Easy dipswitch setup

## Flame current test pads

- Easy on-board checkout

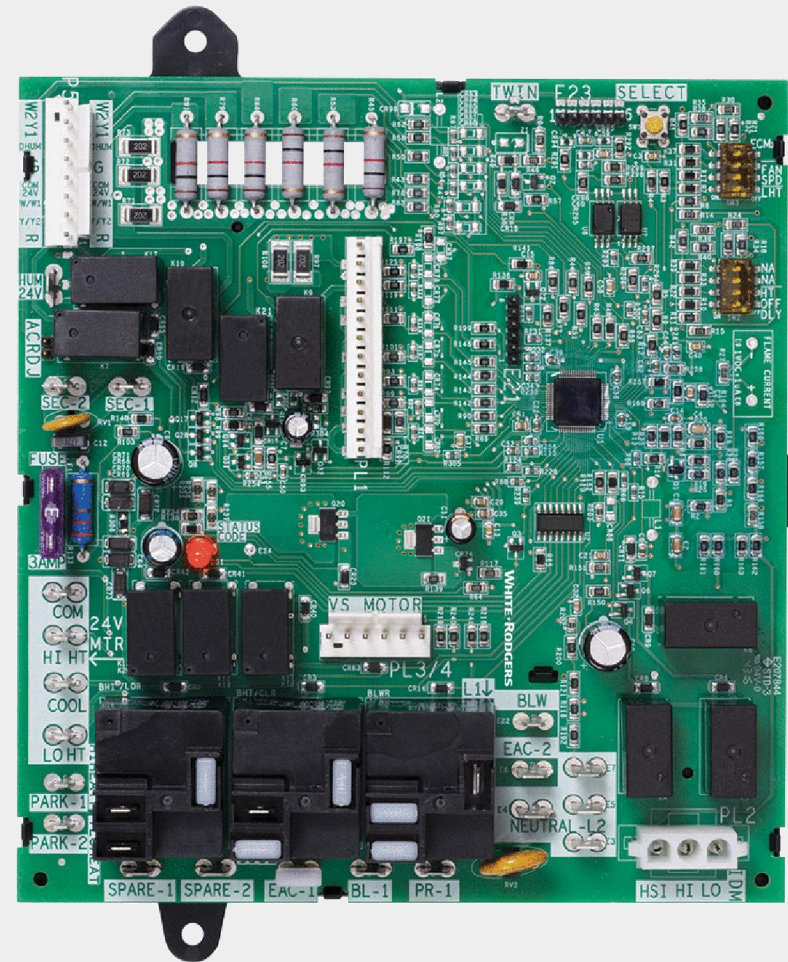

Two-Stage 21V51D-751 replaces carrier/ICP equipment brands blower motor types-PSC, variable speed and ECMx with 120V ignition.

# Installed base

Suitable for many 2-stage furnaces from 1998 to present.

1998	2003	2009	2017
PSC, vs units	PSC, vs units		
"Block" style main harness	"Inline" style main harness	ECMx units	Carrier ends production, ICP continues
			

# White-Rodgers is the Best Choice

## Carrier/ICP Two-Stage 21V51D-751 Replaces 4 OEM SKUs

- #1 Market share equipment brand
- A large installed base built since 1998 OEM product launch
- Covers most applications
  - 20 cross references, OEM SKUs, all Carrier and ICP brands
- Unique combination of the most install and service-friendly features
- Competitive price, less expensive than OEM parts with more applications

White Rodgers	ICM	Honeywell
✓	✓ PSC/VS	✗
	✗ ECMx	✗
	✗ ICP	✗

## Integrated furnace control



**21V51D-751**  
Carrier/ICP

*Two-stage applications*

*PSC/VS or EMCx  
blower motors*

*120V HSI ignition*

*One board for  
all carrier/ICP  
blower motor types*

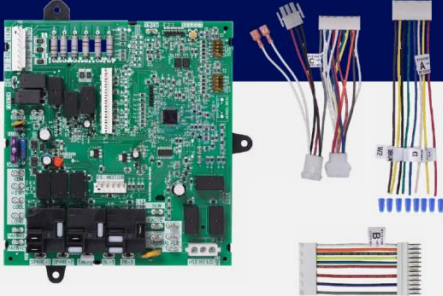

1-Year Limited Warranty

**WHITE • RODGERS**  
by COPELAND



# Replace More Parts with One SKU

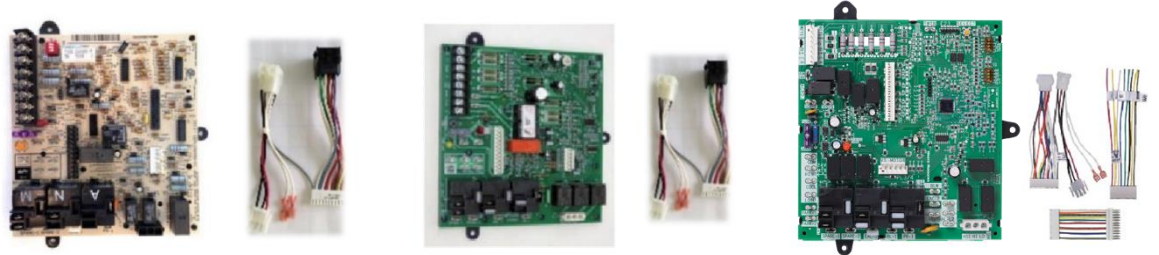

Feature	Carrier/ICP	ICM 2807	WR 21V51D-751
Brands serviced	Carrier & ICP	Carrier only	Carrier & ICP
Capacity/cross reference	4 SKU for 20 cross references	1 SKU for 6 cross references	1 SKU for 20 cross references
Blower motors supported	PSC, VS, ECMx	PSC, VS	PSC, VS, ECMx
PCB material	Cheaper CEM-1	Robust FR4	Robust FR4
Flame current test pads	✗	✗	
LED	Single color	Single color	Tri-color
Status codes (cool & heat stages, fan)	✗	✗	
Retrieve & clear faults	Unplug limit wire	Easy-push button	Easy-push button
Control field self-test	Harder-wire jumper	Harder-wire jumper	Easy-push button
Fan only speed setup	By thermostat often wrong	Jumper	Easy-dipswitch

# Customer driven packaging

Easy to merchandise, select, and use

**2**

## Integrated furnace control

**1**

D
 OEM Direct

**3** **21V51D-751**  
Carrier/ICP

**4**

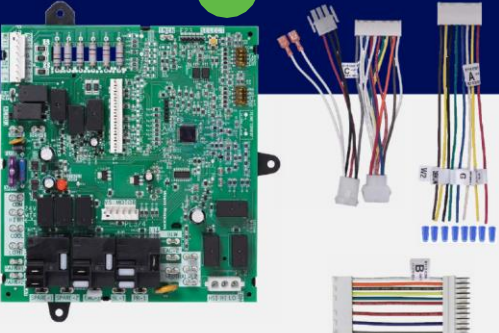

**5**

*Two-stage applications*

*PSC/VS or EMCx blower motors*

*120V HSI ignition*

*One board for all carrier/ICP blower motor types*

1-Year Limited Warranty

**WHITE RODGERS**  
by COPELAND

**6**

Cross Reference Replacement / Tableau de renvoi des remplacements

<p><b>Carrier ECMx</b></p> <p>CEPL130948-01 CEPL130948-02 HK42FZ028 HK42FZ040</p> <p><b>Carrier PSC/VS</b></p> <p>325879-751 CEPL130455-01 HK42FZ005 HK42FZ010 HK42FZ015 HK42FZ017</p> <p><b>ICM PSC/VS</b></p> <p>ICM2807</p>	<p><b>ICP ECMx</b></p> <p>1184408 CEPL131043-01 HK42FZ041</p> <p><b>ICP PSC only/seulement</b></p> <p>1172551 1172809 CEPL130591-01 CEPL130591-41 HK42FZ019 HK42FZ020</p> <p><b>White-Rodgers</b></p> <p>21V51D-751 50V51-751</p>
--	---

1. Direct OEM
2. Product type & color code
  - a) **Red** = indoor units
  - b) **Purple** = outdoor units
  - c) **Gold** = commercial
3. Model number
4. Large product image(s)
5. Key attributes
  - a) Stages
  - b) Blower motor type
  - c) Ignitor voltage
  - d) Other
6. Cross reference on carton

# Comprehensive Cross Reference & Product Information

Find the right part while on the job.

Search by OEM,  
Competitor and  
White-Rodgers  
part numbers.

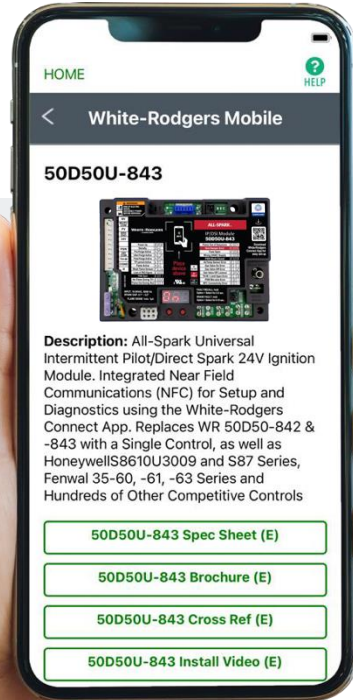

## Your on-the-go resource for:

- Complete cross reference
- Product information and spec sheets
- Installation information and videos
- Wiring diagrams
- Select product by features
- Priority technical support

## WR Mobile App

Search for “WR Mobile” in both Apple and Google Play Stores



## Desktop Version

Access the online version [HERE](#)



# White-Rodgers cross reference

Go to: [www.copeland.com/white-rodgers](http://www.copeland.com/white-rodgers)

- Hover over Support
- Click on: White-Rodgers CrossReference/ Product Information
- Enter the Model Number or click on: Search Replacement Heating Controls by Major OEM Brand

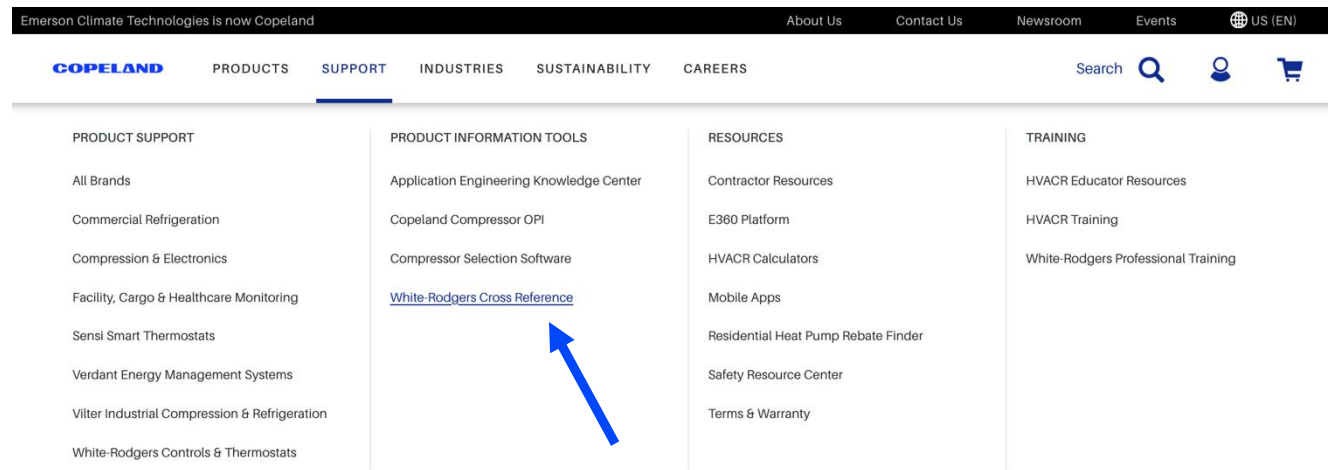

# Wholesale resource site

Access useful resources to grow your business.

Visit: [www.copeland.com/en-us/brands/white-roddgers/white-roddgers-wholesaler-resource-center](http://www.copeland.com/en-us/brands/white-roddgers/white-roddgers-wholesaler-resource-center)

You'll find videos, stocking lists and product launch information for the following product families:

- Heating controls
- Cooling controls
- Sensi smart thermostats
- Traditional thermostats
- Contractor rewards
- Product merchandising

## Online Digital Product Catalog

Our online catalog provides real-time access to product information and digital assets powered by Salsify. Please contact [Joe Thum](#) for assistance.

[ONLINE DIGITAL PRODUCT CATALOG](#)

[VIEW CATALOG](#)



# Why contractors trust White-Rodgers

## Industry leading products

- Used by more OEM's
- Offering the widest range of universal replacement controls

## Ease of installation

- Simple, easy to understand instructions

## Product reliability

- Quality control assures reliable products

## Affordable

- Competitive pricing

## Supported by knowledgeable representatives

- Contractor direct phone support





**COPELAND**

# Technical

21V51D-751 two-stage integrated furnace control



# 21V51D-751 Overview

First of its kind to replace PSC, variable speed and ECMx applications

## Reduces stocking SKUs

- One SKU replaces several OEM and competitive models

## Advance diagnostics for servicing

- Tri-color LED shows operational status and fault codes
- Simple push-button to retrieve fault codes

## Premium home comfort

- Continuous low-speed fan option for better temperature balance and full-time air cleaning
- Easy dipswitch setup

## Flame current test pads

- Easy on-board checkout

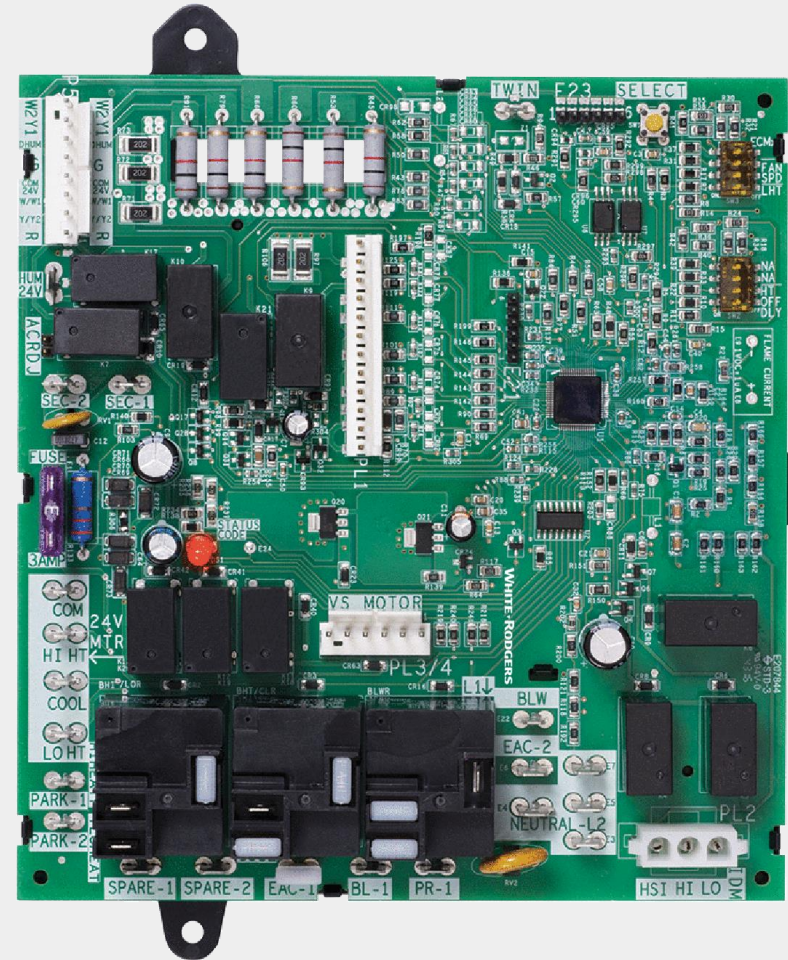

Two-Stage 21V51D-751 replaces carrier/ICP equipment brands blower motor types-PSC, variable speed and ECMxwith 120V ignition.

# 21V51D-751 board layout and key parts

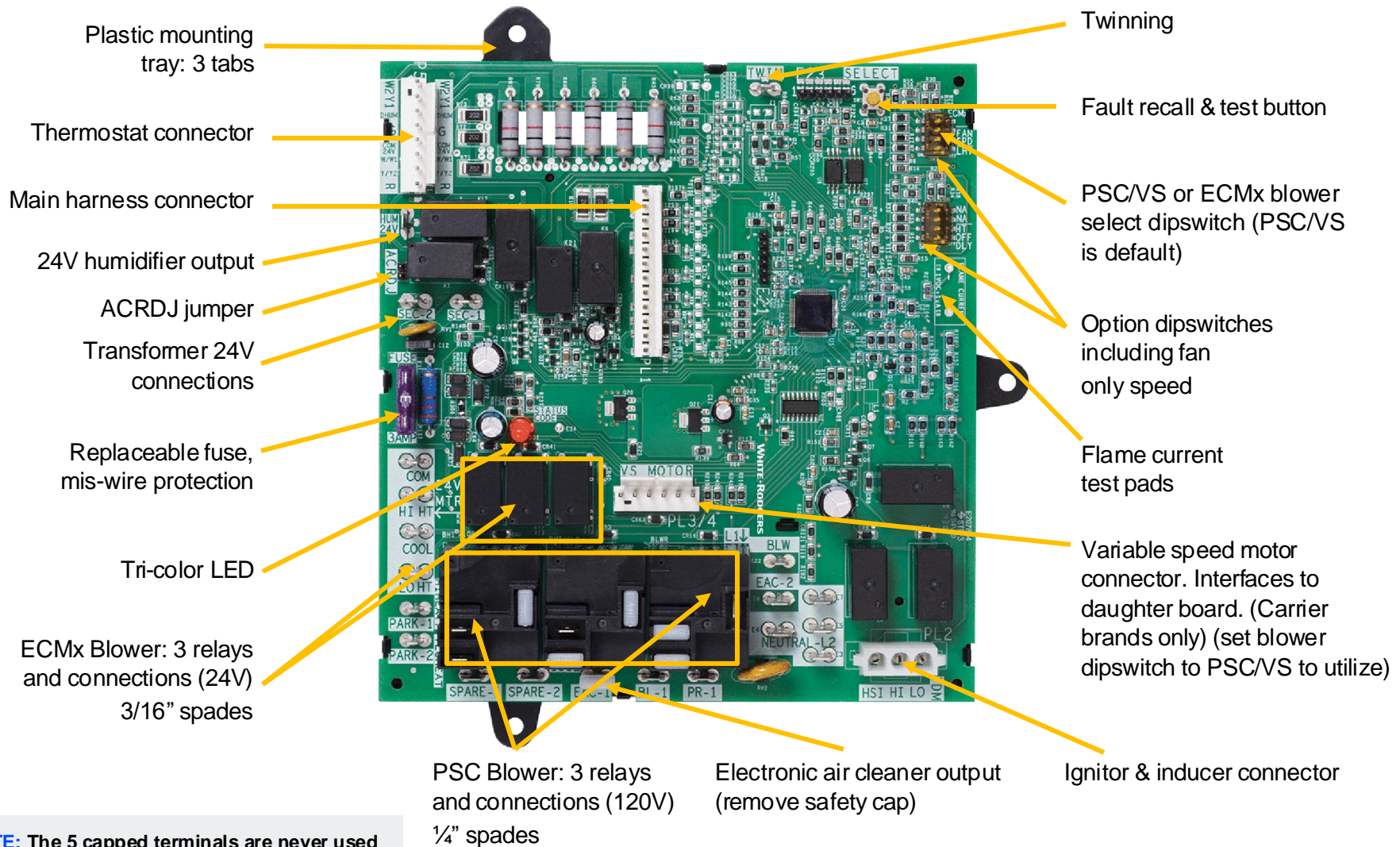

# Replace More Parts with One SKU

Feature	PSC	ECMx	ECM vs 16-pin
Capacitor or software	Capacitor	Software	Software
AC or DC motor	AC	DC	DC
Efficiency	Lower	High	Higher
Supply / control power	Line / line	Line / 24V	Line / 24V
Performance feature	Base	Constant torque	Constant CFM
Daughter card	N/A	N/A	Yes*

**NOTE:** White-Rodgers does not support ICP VS applications due to an uncommon daughterboard scheme.

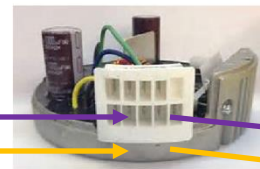

L1/2 supply  
24v control



# Cross Reference

Carrier PSC/VS	Carrier ECMx	ICP PSC Only*	ICP ECMx	ICM PSC/VS
325879-751	CEPL130948-01	1172551	1184408	ICM2807
CEPL130455-01	CEPL130948-02	1172809	CEPL131043-01	
HK42FZ005	HK42FZ028	HK42FZ019	HK42FZ041	
HK42FZ010	HK42FZ040	HK42FZ020		
HK42FZ015		CEPL130591-01		
HK42FZ017		CEPL130591-41		

**NOTE: White-Rodgers does not support ICP VS applications due to an uncommon daughterboard scheme.**



# Easy installation

- Mounts exactly like OEM board
- All key wiring connectors in the same location as original OEM board
- 120 VAC ignitor output
- Confirms installation with push-button self-test routine
- Easily-wired thermostat harness

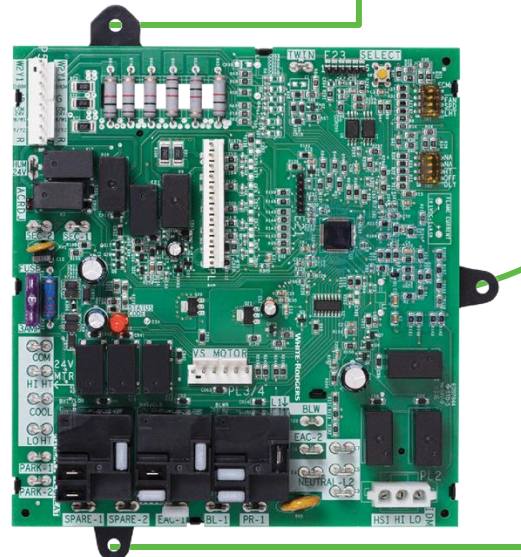
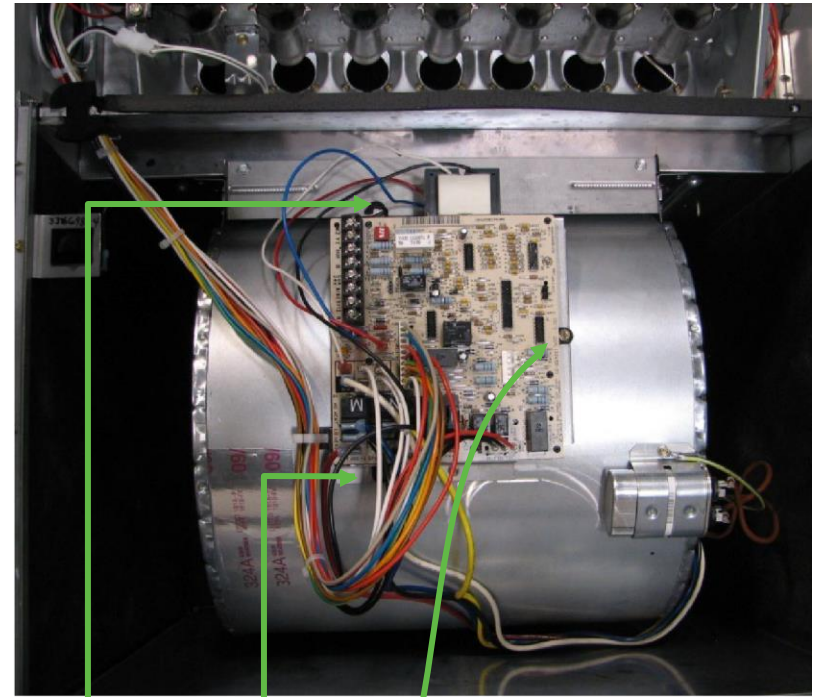



# Specs

## Electrical ratings

**Voltage input:** 18 to 30 VAC, 60 Hz

**Current:** 0.8 amp @25 VAC

## Operating temperature range

-40° to 175°F (-40° to 80°C)

## Humidity range

5 to 95% relative humidity (non-condensing)

## Gasses approved

Natural, manufactured, mixed, liquified petroleum, and LP gas air mixtures are all approved for use.

## Timing specifications

(All times are in seconds unless noted otherwise)

## Flame current requirements

**Min current to insure flame detection:** 0.25  $\mu$ A DC\*

**Max current for non-detection:** 0.1  $\mu$ A DC

**Max allowable leakage resistance:** 150 Mohms

\*Measuring with a DC voltmeter (1VDC = 2  $\mu$ A)

## Operating temperature range

-40° to 175°F (-40° to 80°C)

## Mounting

Plastic tray

Pre-purge	Ignitor warm-up	Retries	Post-purge	Lockout-time	Heat ON delay low heat/high heat	Heat OFF delay	Cool ON delay	Cool OFF delay	Auto reset
15	17	3 Times	15	240	45/25	90/120*/150/180	3	3/90*	60 Mins

\*Default

# Troubleshooting

Fault and status codes | The LED will indicate fault or status codes as shown in the table below:

Green LED Flash	Amber LED Flash	Red LED Flash	Error / Condition
Up to 5 flash codes stored in memory (auto-erased after 14 days)			
		11	No stored codes
		12	Reversed 120 VAC polarity / grounding
		14	Ignition lookout (due to excessive retries)
		15	Ignitor failure
		16	Gas valve de-energized when it should be energized
		21	Gas heating lockout (gas valve energized when it should be de-energized)
		22	Abnormal flame proving signal (flame sensed when flame should not be present)
		23	Low heat pressure switch did not open (shorted pressure switch 1st stage)
		24	Fuse is open
		25	High-heat pressure switch did not open (shorted pressure switch, 2nd stage)
		31	High-heat pressure switch or inducer relay did not close or re-opened (open pressure switch, 2nd stage)
		32	Low-heat pressure switch or inducer relay did not close or re-opened (open pressure switch 1st stage)
		33	Limit circuit fault (open limit or roll out)
		34	Ignition proving failure (due to ignition recycles)

Green LED Flash	Amber LED Flash	Red LED Flash	Error / Condition
Flash codes NOT stored in memory			
OFF	OFF	OFF	No 120VAC and 24 VAC power control circuitry lockout
Alternate	Alternate	Alternate	Self-test mode active
Solid ON			Standby
Rapid flash			Fan Only Call
1			Call for low cool
2			Call for high cool
3			Blower on after power up
	Rapid flash		Weak flame error
	1		Call for low cool
	2		Call for high cool
	3		Defrost mode
		Rapid flash	Twinning error

**NOTE:** Rapid flash LED flash code uses 250ms ON time and 250ms OFF time. Two-digit red LED flash codes use 1s ON time, 250ms OFF time. There is a 1s OFF time between 1st and 2nd digit of the error code. There is a 2s OFF time between each error code.

**COPELAND**

# Install

21V51D-751 two-stage integrated furnace control



# Introduction



The 21V51D-751 is a two-stage HSI integrated furnace control kit for many carrier and ICP equipment brands with PSC, variable speed, and ECMxBlowers configured via dipswitch selection.

With 3 harness assemblies, the 21V51D-751 cross references 20 different OEM part numbers.

**NOTE:** 21V51D-751 CANNOT be twinned with any carrier, ICP, or ICM brand controls. Both control boards must be from the same manufacturer for proper functionality.

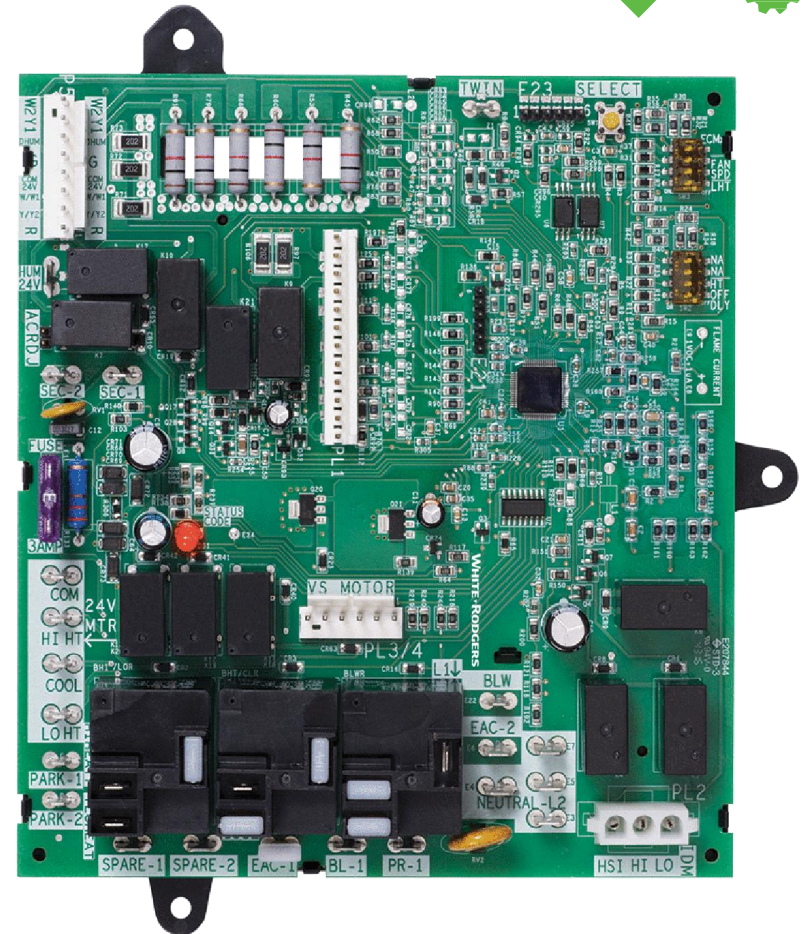

# What's in the Box?

1  
carrier  
two-stage  
21V51D-751 +  
mounting tray



1  
instruction  
sheet  
available in three  
languages (SP online)



3  
harness  
assemblies

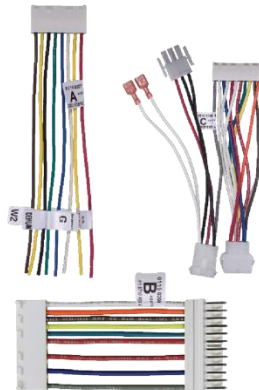

1  
control  
label



8  
wire  
nuts





# Feature and design

## Accessory wiring adapters

### Harness "A" – thermostat

Use with the included wire nuts to make the thermostat connections, then plug onto control. Wires are color coded and tagged for easy ID.

Easy wiring: make connections without working inside furnace, then plug-on when ready to finish install.

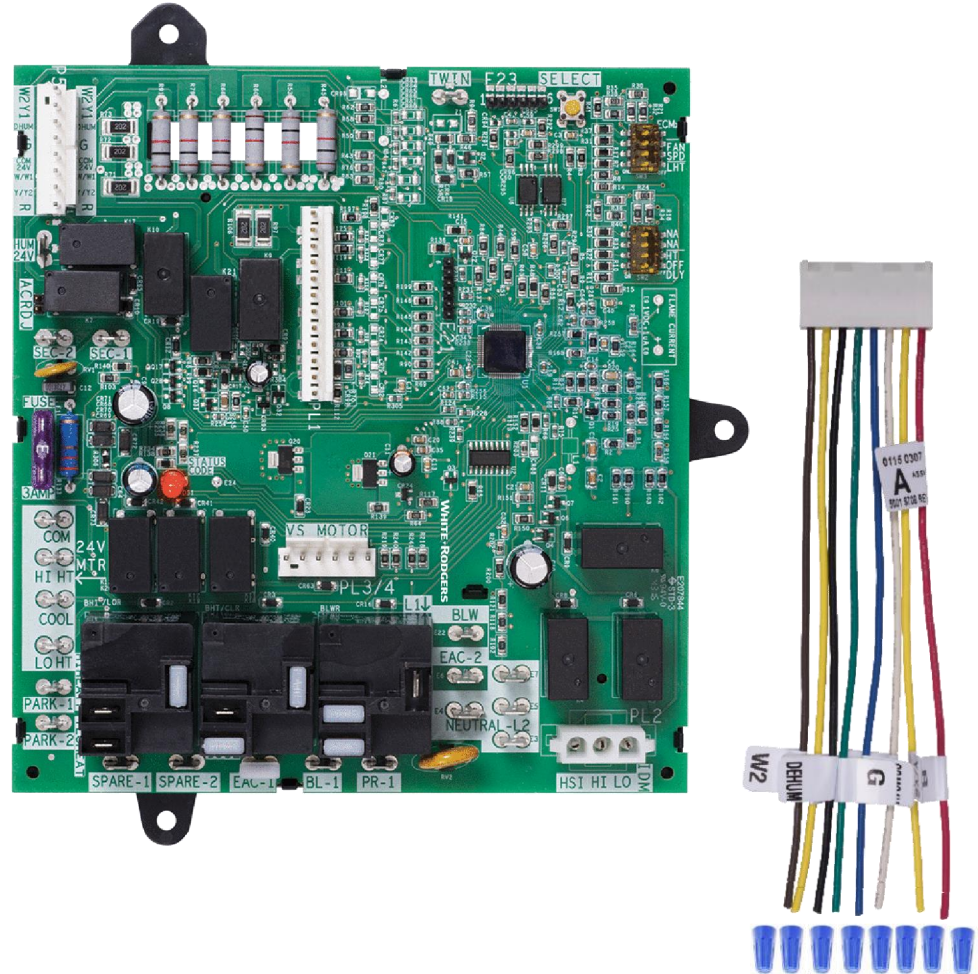



# Feature and design

Accessory wiring adapters

## Harness “B” – the ICP “Flip”

Used to convert the Carrier control board inline main harness pinout to the reversed ICP pinout.

Because of the locking polarized tab on the mating connectors, you can't simply invert the existing wiring. But flipping our B harness allows the pins to match up perfectly.

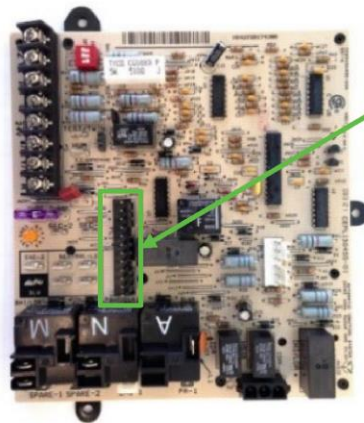

1-2-3-4-5-6-7-8-9-10-11-12

The ICP “Flip”

12-11-10-8-7-6-5-4-3-2-1



# Feature and design

Accessory wiring adapters

## Harness “C” – block to inline converter

Used with older style furnaces having “block” style main system connector.

Converts wiring to use new style board with “inline” style connector. (Carrier and ICM have a similar harness in their kits.)



“Block” style circa 1998

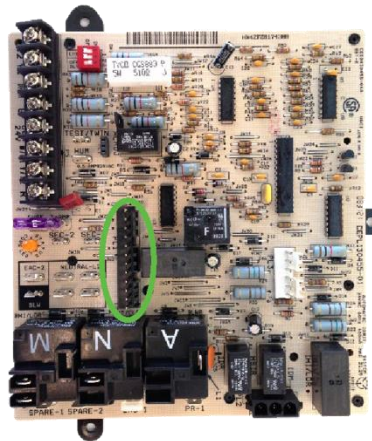

“Inline” style started 2003

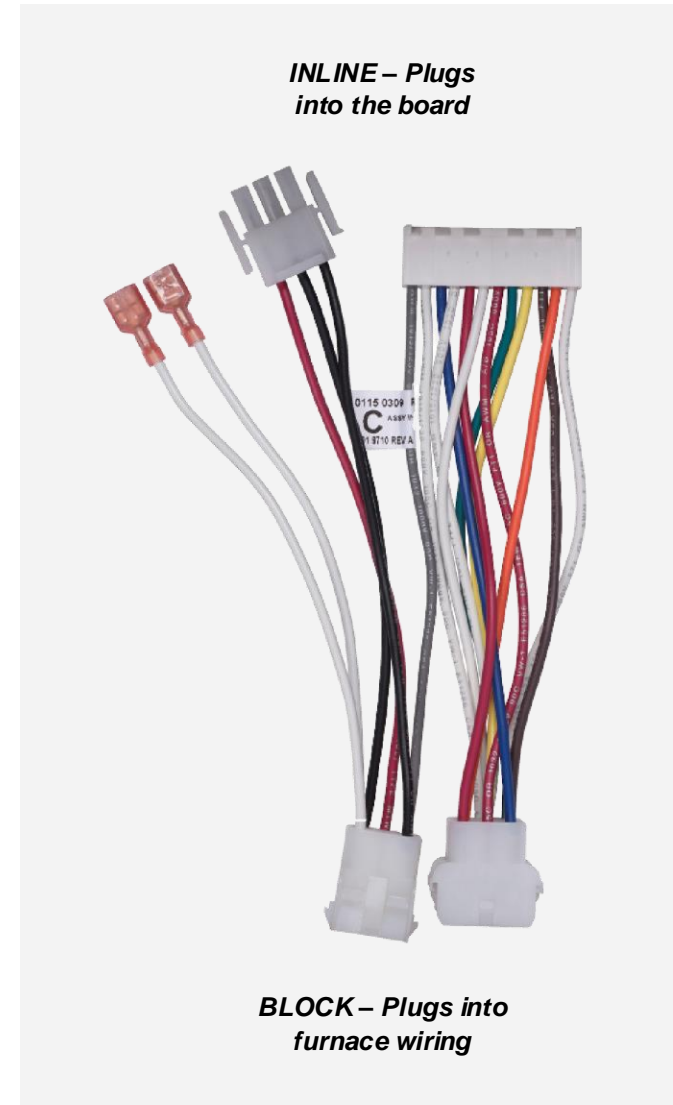

**INLINE** – Plugs into the board

**BLOCK** – Plugs into furnace wiring

# Harness selection table

Control	Brand	Blower	Thermostat “A”	ICP Flip “B”	Old Style Carrier “C”	Control
CEPL130948-01	Carrier	ECMx	✓			CEPL130948-01
CEPL130948-02						CEPL130948-02
HK42FZ028						HK42FZ028
HK42FZ040						HK42FZ040
325879-751						325879-751
CEPL130455-01		PSC / VS				CEPL130455-01
HK42FZ017						HK42FZ017
HK42FZ005						HK42FZ005
HK42FZ010						HK42FZ010
HK42FZ015						HK42FZ015
ICM2807	ICM	PSC/VS			ICM2807	
1184408	ICP	ECMx				1184408
CEPL131043-01						CEPL131043-01
HK42FZ041						HK42FZ041
1172551						1172551
1172809						1172809
CEPL130591-01		PSC Only				CEPL130591-01
CEPL130591-41						CEPL130591-41
HK42FZ019						HK42FZ019
HK42FZ020						HK42FZ020

# Pre-install steps

**NOTE:** All wiring should be installed according to local and national electrical codes and ordinances.

1. Disconnect electrical power and gas supply to unit, then remove unit access panel.
2. Mark and disconnect all wires from the existing control, then remove existing control. (It's always a good idea to snap a quick picture).
3. Refer to the harness descriptions, harness table, wiring diagram, and dipswitch configurations to connect and setup new control board to unit.

**⚠ CAUTION**

 Risk of Electric Shock. Disconnect electric power to system until installation is complete. Do not use on circuit exceeding specified voltage. Higher voltage will damage control and could cause shock or fire hazard.

 Risk of Electric Shock. Disconnect electric power to system until installation is complete. Do not use on circuit exceeding specified voltage. Higher voltage will damage control and could cause shock or fire hazard.

 This control is not intended for use in locations where it may come in contact with water.

 May cause flame rollout. Shut off main gas to heating system until installation is complete.

# Wiring diagram

**NOTE:** A full-size wiring diagram is included within the instruction sheet in every box.

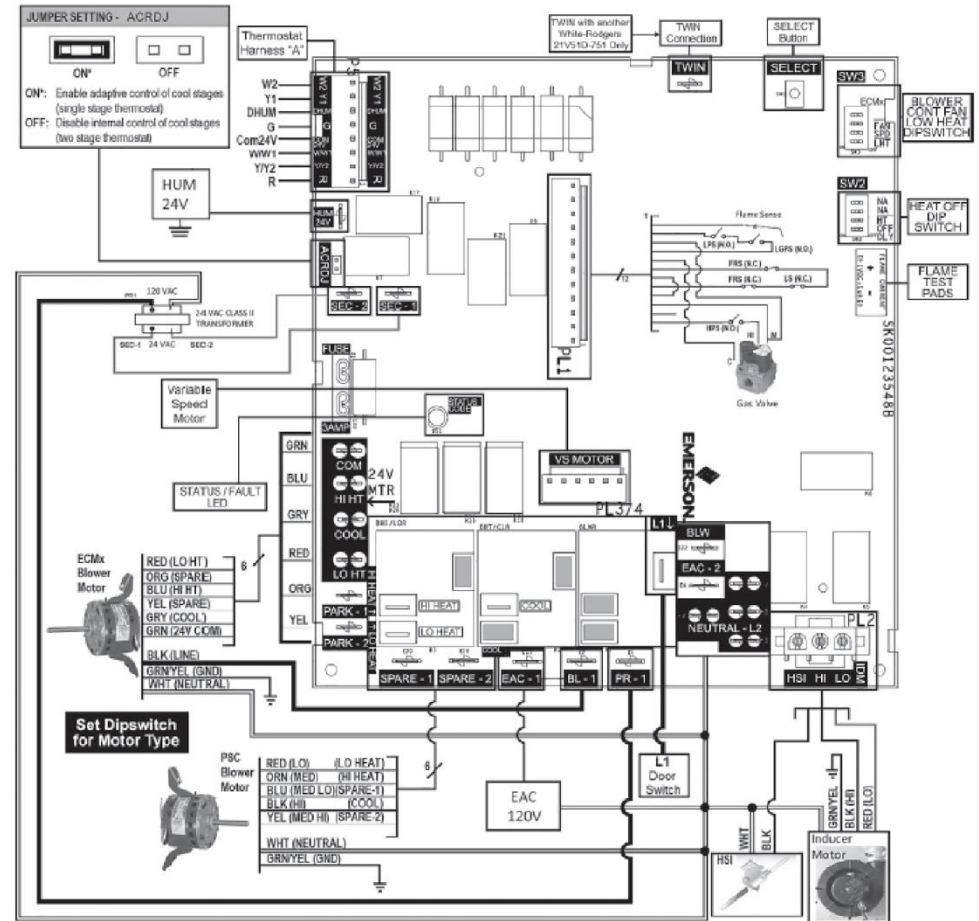



# Dipswitch configuration

**NOTE:** To change settings break through yellow protective plastic film and make adjustments.

## Blower motor type

- Default operation PSC/VS

## Low heat only mode

- Default operation OFF (single stage thermostat)

## Heat off delay

- Default operation 120 seconds

## Continuous fan speed

- Default operation low heat speed

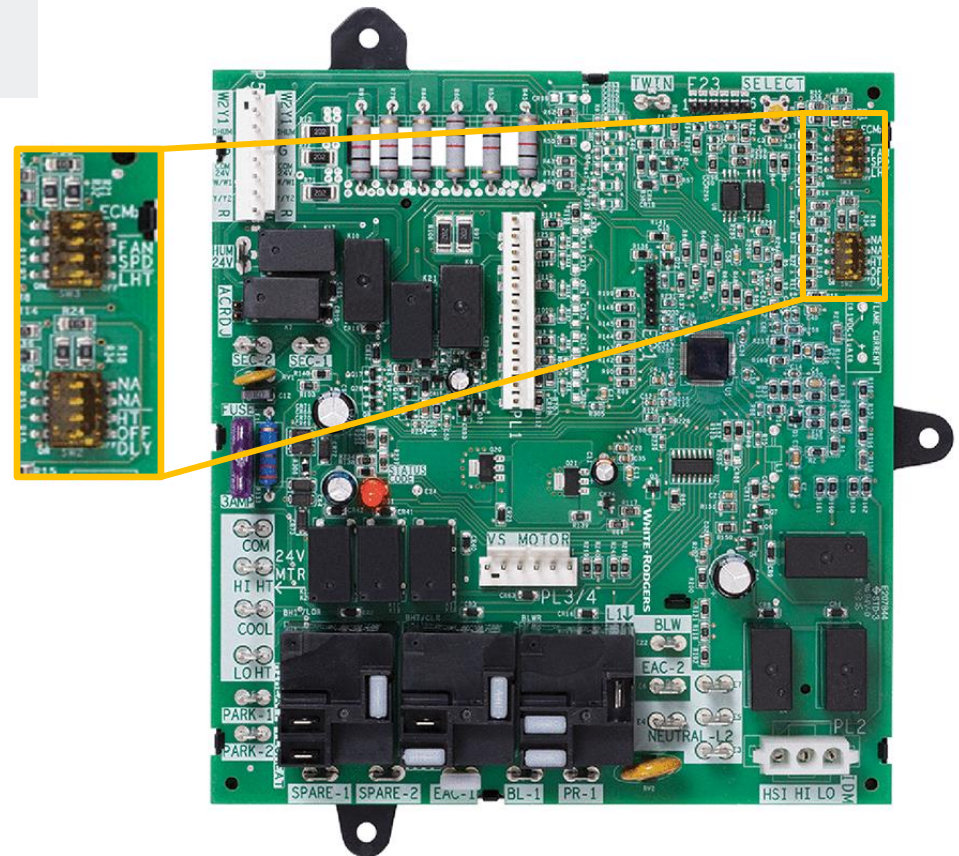

*Shown switched to ECMxin this example*



# Dipswitch configuration

Blower type and low heat only

Dipswitches must be set for blower type the board is being configured for.

**NOTE:** Cycle power after changes are made.

If configuring for ECMx, dipswitch must be switched to OFF position.

“Low Heat Only” dipswitch selection allows a single stage thermostat to remain installed, where traditionally a new thermostat would be required.

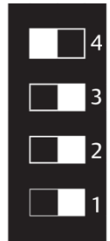
DIPSWITCH SETTINGS	
Blower Type Configuration	Low Heat Only Mode
<p>SW3</p> <p>PSC/ VS*</p>  <p>4 ECMx</p> <p>3</p> <p>2</p> <p>1</p> <p>ON OFF</p>	<p>SW3</p>  <p>4</p> <p>3</p> <p>2</p> <p>1 LHT</p> <p>ON OFF</p> <p><b>OFF*:</b> Enable adaptive control of heat stages (single stage thermostat)</p> <p><b>ON:</b> Disable internal control of heat stages (two stage thermostat)</p>

# Variable speed notes

Carrier brands only – ICP brands not supported

- Ensure blower type dipswitch is set to PSC / VS.
- The green DEHUM wire from the VS motor connects to G terminal (green wire of “A” harness) if previously connected to G on original control board. Cut the existing 1/4” spade terminal off, strip the wire and attach with a supplied wire nut.
- NOTE: The green DEHUM wire from the VS motor may have been spliced to a thermostat wire connected to a Carrier Thermidistat™ DHUM terminal. Leave it this way and DO NOT connect it to the DHUM terminal (black wire of “A” harness) on new control board.
- The 2 white wires previously connected to the 1/4” HUM spade terminal of the original control board need to be connected to the 1/4” HUM 24V terminal on the new control board.

**NOTE:** For variable speed units, plug existing 6-pin connector from daughter board to “VS MOTOR” PL3/4 on new control board.

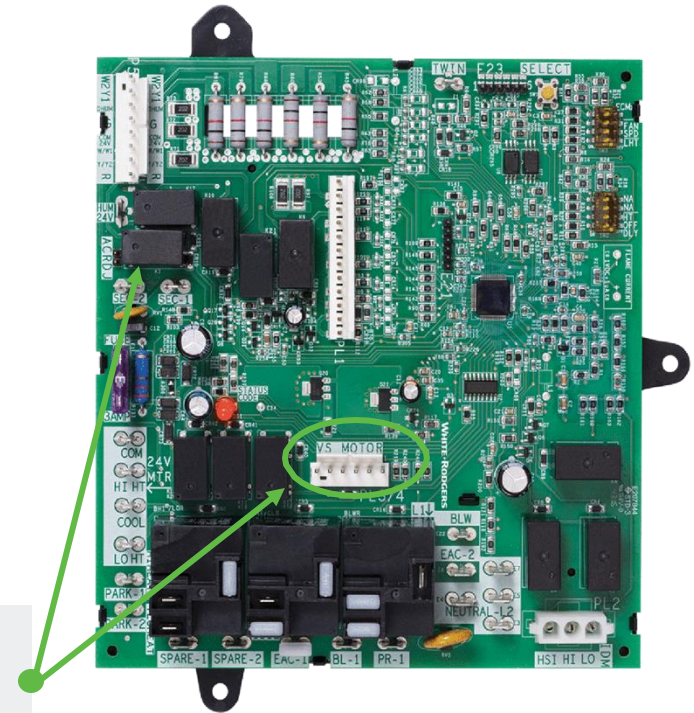
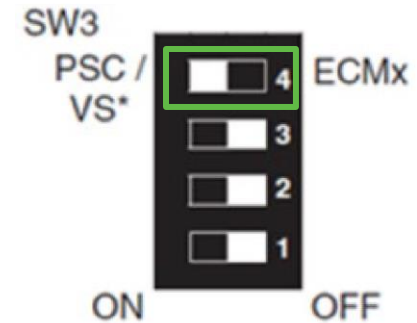

# Dipswitch configuration

## Heat off delay

Set dipswitch for desired blower run time at the end of a heating cycle.

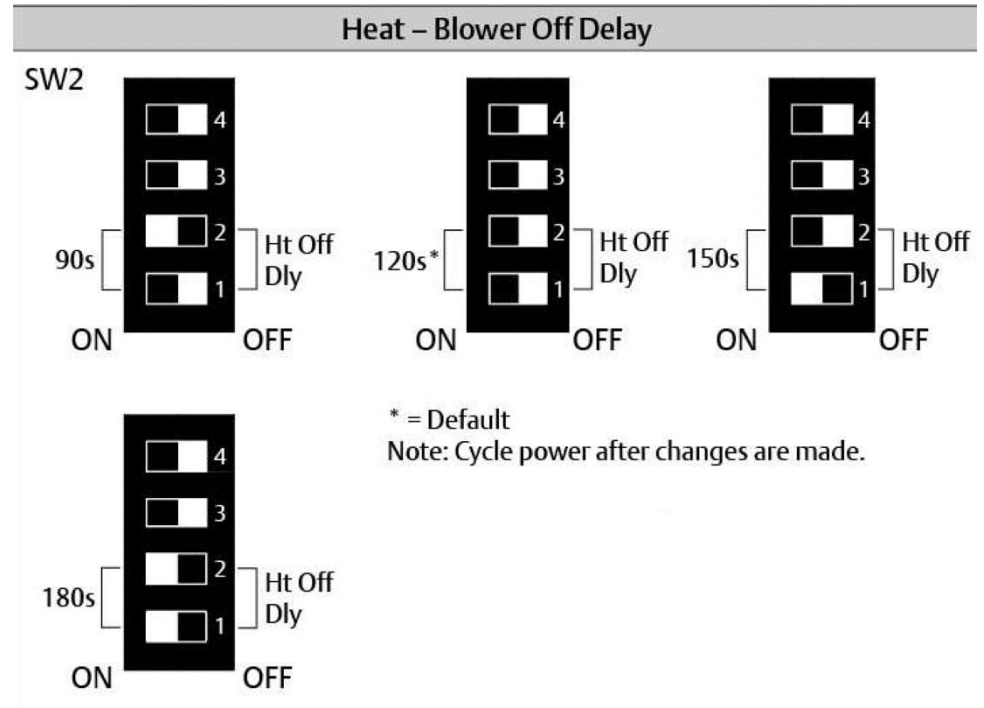

# Dipswitch configuration

## Fan only speed

Carrier requires that continuous fan speed is set through the thermostat.

- OEM control board installs can be accidentally set for an undesired fan only speed.
- Occurs when the G terminal gets “toggled” with 24VAC by accident.
- Can result in functional parts being replaced.

White-Rodgers 21V51D-751 uses easy-to-understand dipswitch to set fan speed setup which cannot get “toggled” accidentally.

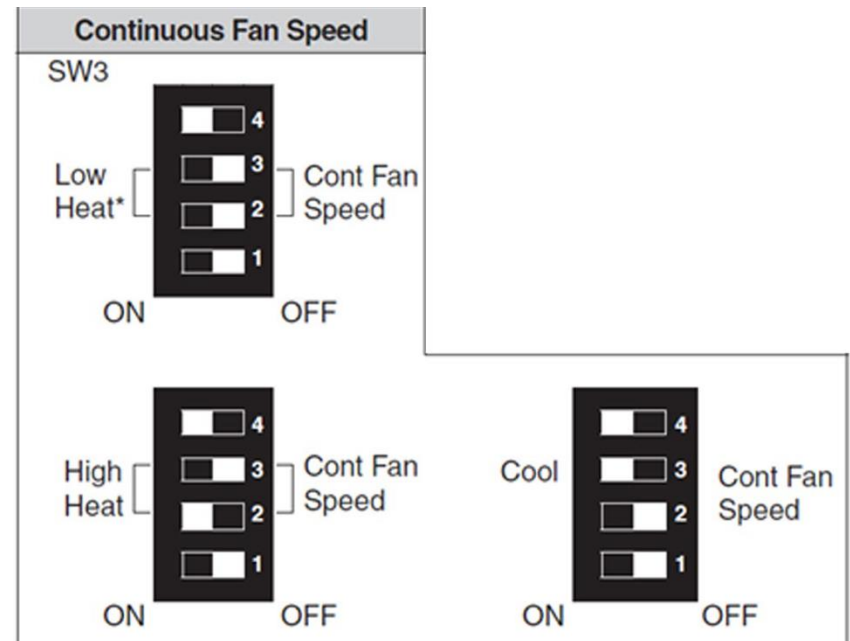

# Air conditioning relay disable jumper

(Adaptive cooling)

- The 21V51D-751 can operate a two-speed A/C unit with a single-stage thermostat using an adaptive algorithm which selects between low-cooling or high-cooling operation.
- MEANING: No need to replace a thermostat!
- Control engages a two-stage cool operation, based on run time, without a two-stage thermostat.
- For single stage thermostat applications with a two-stage outdoor unit, just ensure the **ACRDJ jumper** is present to pass operation to the 21V51D-751.

**NOTE:** For adaptive cooling operation, connect thermostat cool input to Y1 terminal (yellow wire of "A" harness).

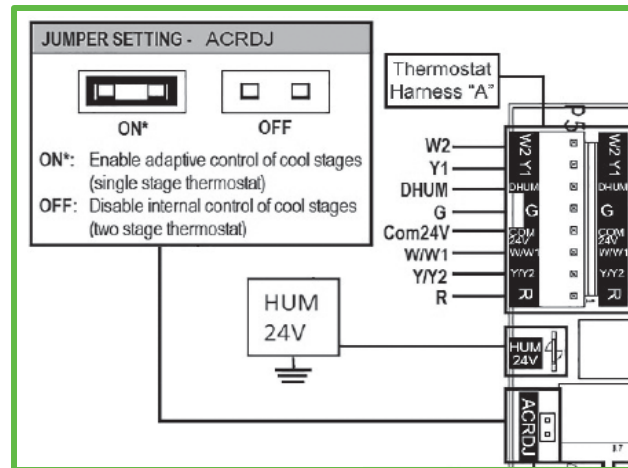





# 21V51D-751 Self-Test

## Self-Test procedure:

- Runs each component after install to ensure proper operation.
  - Checks the functionality of the control, ignitor, inducer, and blower.
- Easily-accessible push-button
- Ensure the thermostat is turned OFF or thermostat wires are disconnected to enable.

**NOTE:** Self-Test is available after power up and until a solid green LED is present (5 seconds after power up). During this time, the control will ignore all active calls. If a solid green LED is present, disconnect power for 10 seconds and retry.

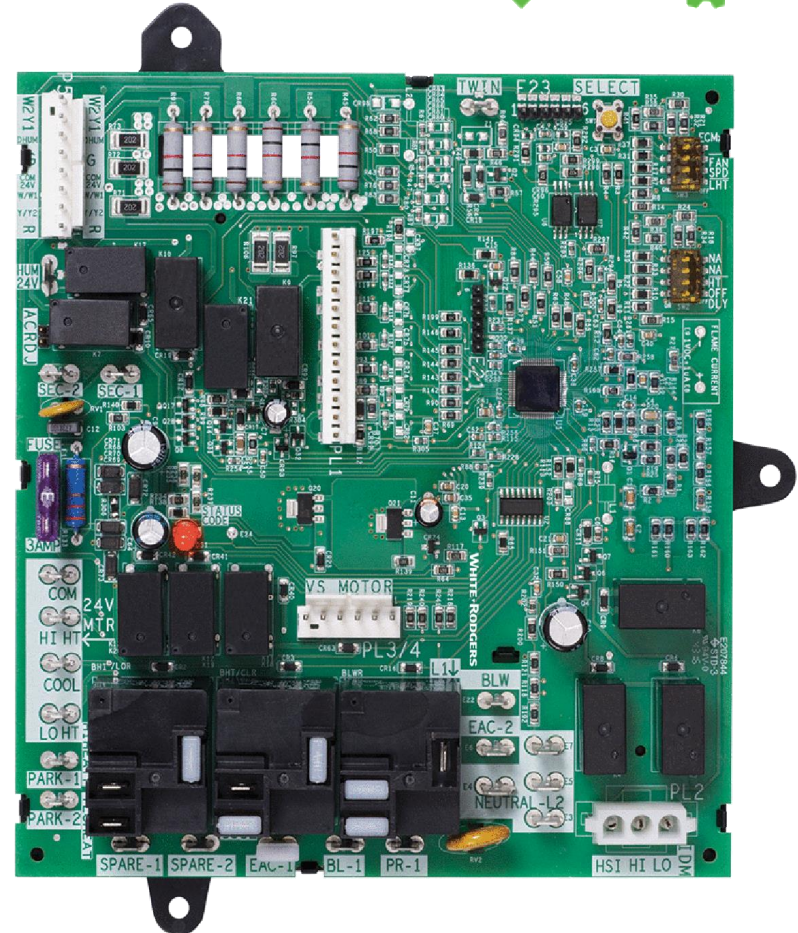

# 21V51D-751 self-test operation



## Enter Self-Test by:

- Turn on power and manually close blower door switch.
- Wait 1 second.
- Slowly double-click SELECT button within 3 seconds.



## Sequence is as follows:

- LED will flash in red the previous error code 4 times
- Afterward, the LED will slowly flash alternate colors (red, amber, green) to indicate Self-Test is active and continue until Self-Test is complete
  - Inducer motor will turn ON at HIGH speed and continue running until Self-Test is complete
  - After 7 seconds, the ignitor will turn ON for 15 seconds, then OFF
  - Blower motor operates on LOW HEAT speed for 10 seconds
  - Blower motor operates on HIGH HEAT speed for 10 seconds
  - Blower motor operates on COOL speed for 10 seconds
  - Blower motor turns OFF
  - Inducer motor goes to LOW speed for 10 seconds and then turns OFF
- LED will display solid green to indicate standby mode

# Troubleshooting

Fault and status codes | The LED will indicate fault or status codes as shown in the table below:

Green LED Flash	Amber LED Flash	Red LED Flash	Error / Condition
Up to 5 flash codes stored in memory (auto-erased after 14 days)			
		11	No stored codes
		12	Reversed 120 VAC polarity / grounding
		14	Ignition lookout (due to excessive retries)
		15	Ignitor failure
		16	Gas valve de-energized when it should be energized
		21	Gas heating lockout (gas valve energized when it should be de-energized)
		22	Abnormal flame proving signal (flame sensed when flame should not be present)
		23	Low heat pressure switch did not open (shorted pressure switch 1st stage)
		24	Fuse is open
		25	High-heat pressure switch did not open (shorted pressure switch, 2nd stage)
		31	High-heat pressure switch or inducer relay did not close or re-opened (open pressure switch, 2nd stage)
		32	Low-heat pressure switch or inducer relay did not close or re-opened (open pressure switch 1st stage)
		33	Limit circuit fault (open limit or roll out)
		34	Ignition proving failure (due to ignition recycles)

Green LED Flash	Amber LED Flash	Red LED Flash	Error / Condition
Flash codes NOT stored in memory			
OFF	OFF	OFF	No 120VAC and 24 VAC power control circuitry lockout
Alternate	Alternate	Alternate	Self-test mode active
Solid ON			Standby
Rapid flash			Fan Only Call
1			Call for low cool
2			Call for high cool
3			Blower on after power up
	Rapid flash		Weak flame error
	1		Call for low cool
	2		Call for high cool
	3		Defrost mode
		Rapid flash	Twinning error

**NOTE:** Rapid flash LED flash code uses 250ms ON time and 250ms OFF time. Two-digit red LED flash codes use 1s ON time, 250ms OFF time. There is a 1s OFF time between 1st and 2nd digit of the error code. There is a 2s OFF time between each error code.



# Troubleshooting fault recall and reset



## Fault recall

When the control is in standby mode (no call for heat or cool), press the "SELECT" button for approximately 2 to 5 seconds or until the diagnostic LED turns off. Up to 5 fault codes are stored.

**NOTE:** While displaying the stored fault codes, the control will ignore any new call for heat, cool or fan.

## Reset

When the control is in standby mode (no call for heat or cool), press the "SELECT" button for 5 to 10 seconds or until the diagnostic LED begins to rapid flash.

**NOTE:** If the switch is held pressed for over 10 seconds, the rapid flash will stop and the LED will be on to indicate return to normal status.

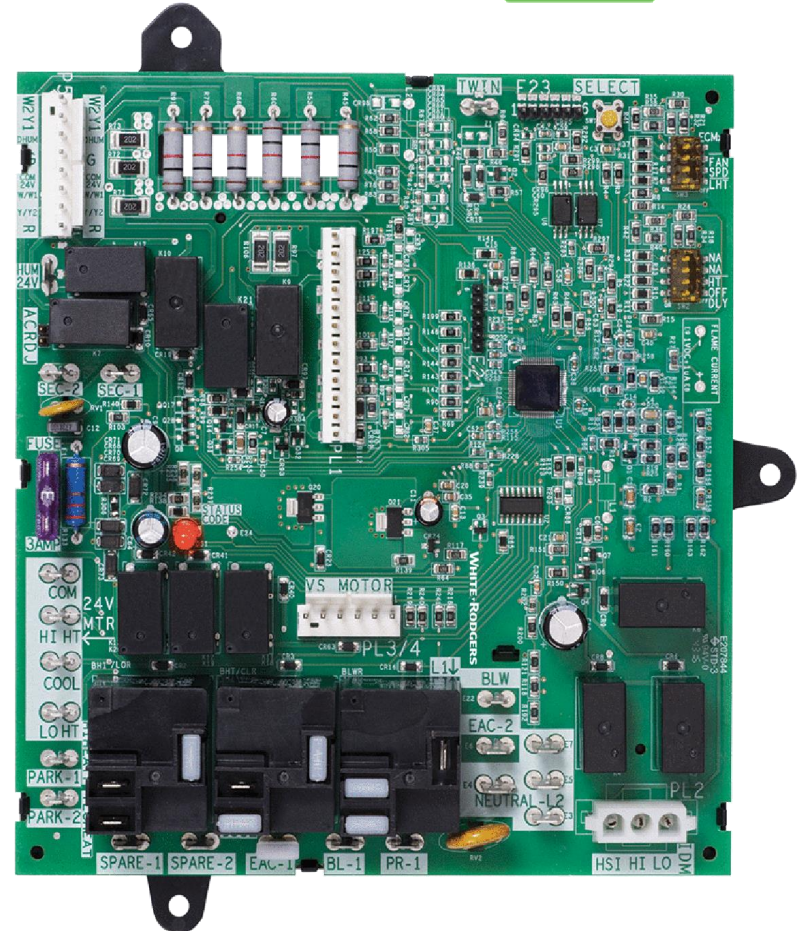



# Troubleshooting flame current test pads

## Flame current test pad feature

Easy access test pads provide valuable diagnostic information to technicians and improve service call performance.

- Set meter to DC volt scale and place leads on test pads with the furnace burners on.
- Reading results: 0.5 – 1.0 = marginal, 1.0 – 5.0 = good
- Note: Lower than acceptable readings will cause furnace control to halt operation and display a rapid **Amber LED flash** code = weak flame error (as shown on control box label). Flame sensor should be cleaned or replaced as needed.

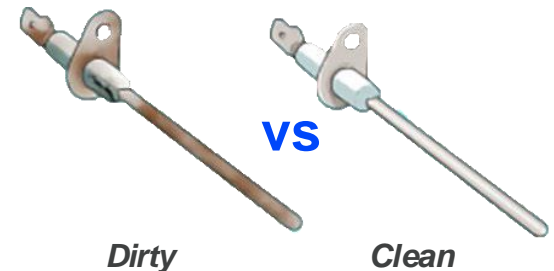
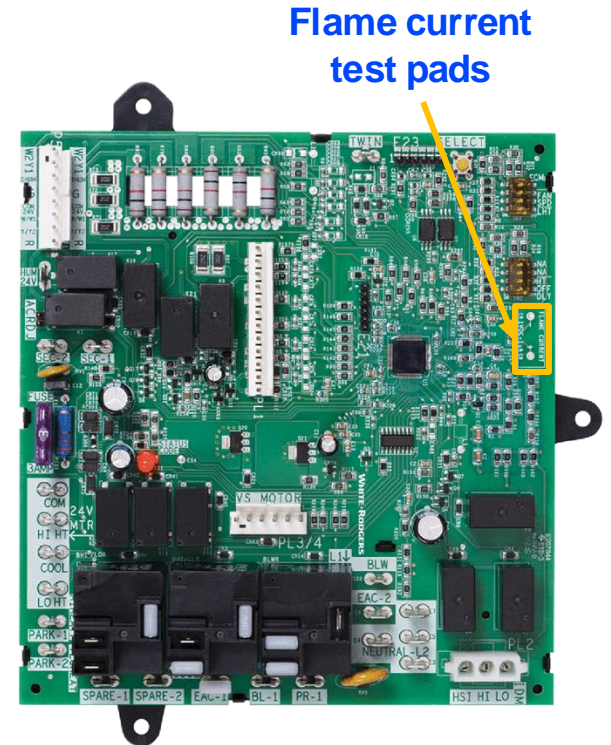

**COPELAND**