

# E2 Noise Abatement Kit Instructions

The E2 Noise Abatement Kit (P/N 637-4801) is designed to replace components on some E2 units to increase the controller's resistance to electromagnetic interference (EMI, sometimes commonly referred to as **noise**).

The kit consists of the following components:

Table 1 - Kit P/N 637-4801 Components

Component P/N	Description
335-0002	Ground wire (6 inches, 14 AWG, w/ spade lug on one end)
335-3906	39-pin replacement ribbon cable
026-4126	This document

## Kit Installation Instructions

1. Before installing this kit, it is recommended you perform a backup of the controller's configuration. Connect to the controller with UltraSite32, right-click the unit in the Tree View, and select **Backup**. Refer to the UltraSite32 User's Guide (026-1002) for instructions.
2. Open the door to the E2 controller to expose the processor board and power interface board (PIB).
3. Flip the power switch to the OFF position to power down the E2.

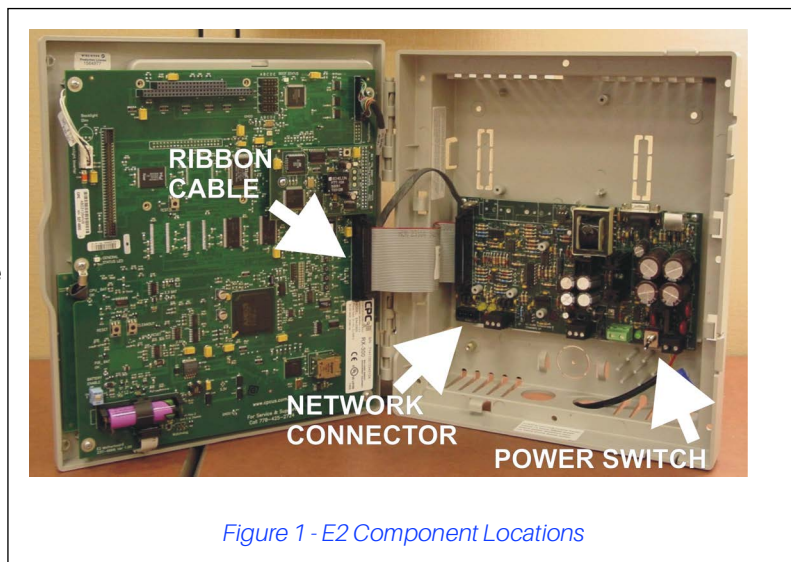

## Ribbon Cable Replacement

1. Locate the ribbon cable connecting the processor board with the PIB. If this E2 has not yet been upgraded, the cable will be gray with one red stripe along the top edge of the cable, as pictured in **Figure 1**; proceed with step 5 to replace this cable. If the cable on the E2 has a vertical blue stripe on both ends next to the connectors (similar to the 335-3906 cable in the kit), **this E2 has already been upgraded and you will not need to replace the ribbon cable.**
2. Remove the ribbon cable from the connectors on the processor board and PIB. To remove the cable ends from the connector, use your thumbs to push the tabs on the ends of the connectors outward.
3. Plug in the 39-pin replacement ribbon cable from the kit. Press the cable ends firmly into the connectors until the tabs lock the connector into place (you should hear and feel a click when seated correctly). If oriented correctly, the red stripe along the edge of the ribbon cable will be on the top side of the cable.

## RS485 Ground Wire Installation

1. Locate the two RS485 network ports on the bottom left corner of the PIB. Using the 14AWG ground wire from the kit, connect the stripped end of the wire to the 0V terminal of an RS485 port in use. Connect the end with the lug attached to a solid earth ground outside of the E2 enclosure, as shown in **Figure 2**.  
Approved earth ground types include:
  - A large metal panel or plate that is connected to a good electrical ground. A panel or plate that is at least 3 feet by 3 feet (0.9 m by 0.9 m) is desirable.
  - Earth grounded steel rack.
  - Water pipes (metal, assuming there are no plastic sections).
  - Electrical system earth ground.

**Note: If grounding against a metal plate or panel that is coated or painted, scrape away the coating to expose the bare metal before making the ground attachment.**

2. If using the I/O expansion card (COM4), you must also connect the 0V terminal of a port in use to a separate earth ground, using a 14AWG wire no longer than six (6) inches (not included in the kit).
3. If using the RS485 port on the Modem/Communication Expansion Card, for maximum noise protection it is recommended you do not connect anything to the 0V terminal. Connect the shield for the COM6 wire to an earth ground outside of the enclosure, NOT the 0V terminal on the COM6 port.
4. Restore power to the E2 controller. The controller is now upgraded and ready for use.

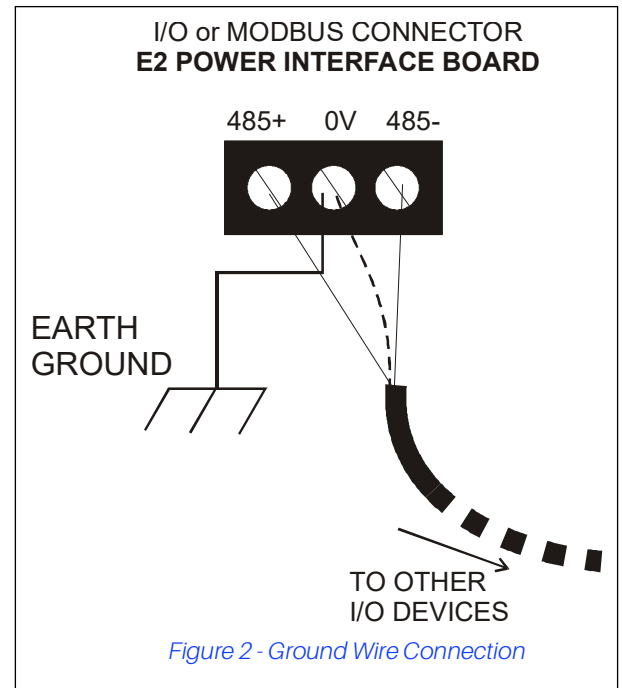

Visit our website at [copeland.com/en-us/products/controls-monitoring-systems](https://copeland.com/en-us/products/controls-monitoring-systems) for the latest technical documentation and updates.  
For Technical Support call **833-409-7505** or email [ColdChain.TechnicalServices@Copeland.com](mailto:ColdChain.TechnicalServices@Copeland.com)