

COPELAND

Copeland
digital outdoor
refrigeration unit

X-Line series



Digital X-line series

Innovative

Energy efficient

Flexible



Applications

Display cases



Convenience stores

Walk-in coolers



Supermarkets

Process chillers



Restaurants

Food preparation



Industrial

Features and benefits

Digital, multiplexing technology

Multiple cases per unit



Capacity range (95° ambient)

Medium temp R-404A +25°F evap																											
XFAM-030D				■	■	■	■	■	■	■	■	■	■	■	■	■	■	■	■	■	■	■	■	■	■	■	
XFAM-040D				■	■	■	■	■	■	■	■	■	■	■	■	■	■	■	■	■	■	■	■	■	■	■	
XFAM-050D				■	■	■	■	■	■	■	■	■	■	■	■	■	■	■	■	■	■	■	■	■	■	■	
XFAM-060D				■	■	■	■	■	■	■	■	■	■	■	■	■	■	■	■	■	■	■	■	■	■	■	
	0	2	4	6	8	10	12	14	16	18	20	22	24	26	28	30	32	34	36	38	40	42	44	46	48	50	52

Refrigeration load (kbtu/hr)

Features and benefits

Installation benefits, operational benefits, and capacity modulation

Installation benefits

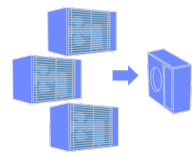

Fewer units to install and maintain

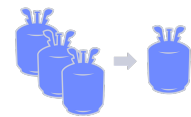

Reduced refrigerant charge and line sets



Lightweight and flexible installation options



Reduced costly call backs with advanced diagnostics



Simple and quick commissioning



Slim chassis and easy installation

Operational benefits



Advanced diagnostics

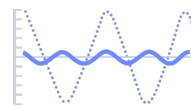

Tight temperature precision



Energy efficient



Ultra quiet operation

Capacity modulation

100% down to 20%

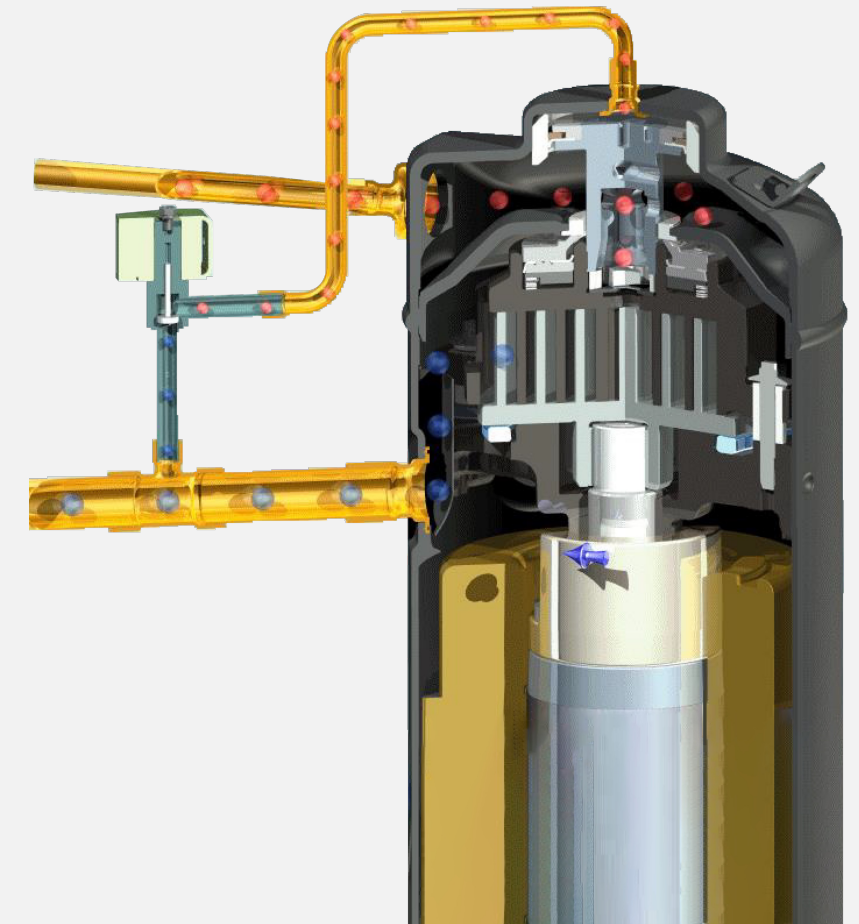

What's inside?

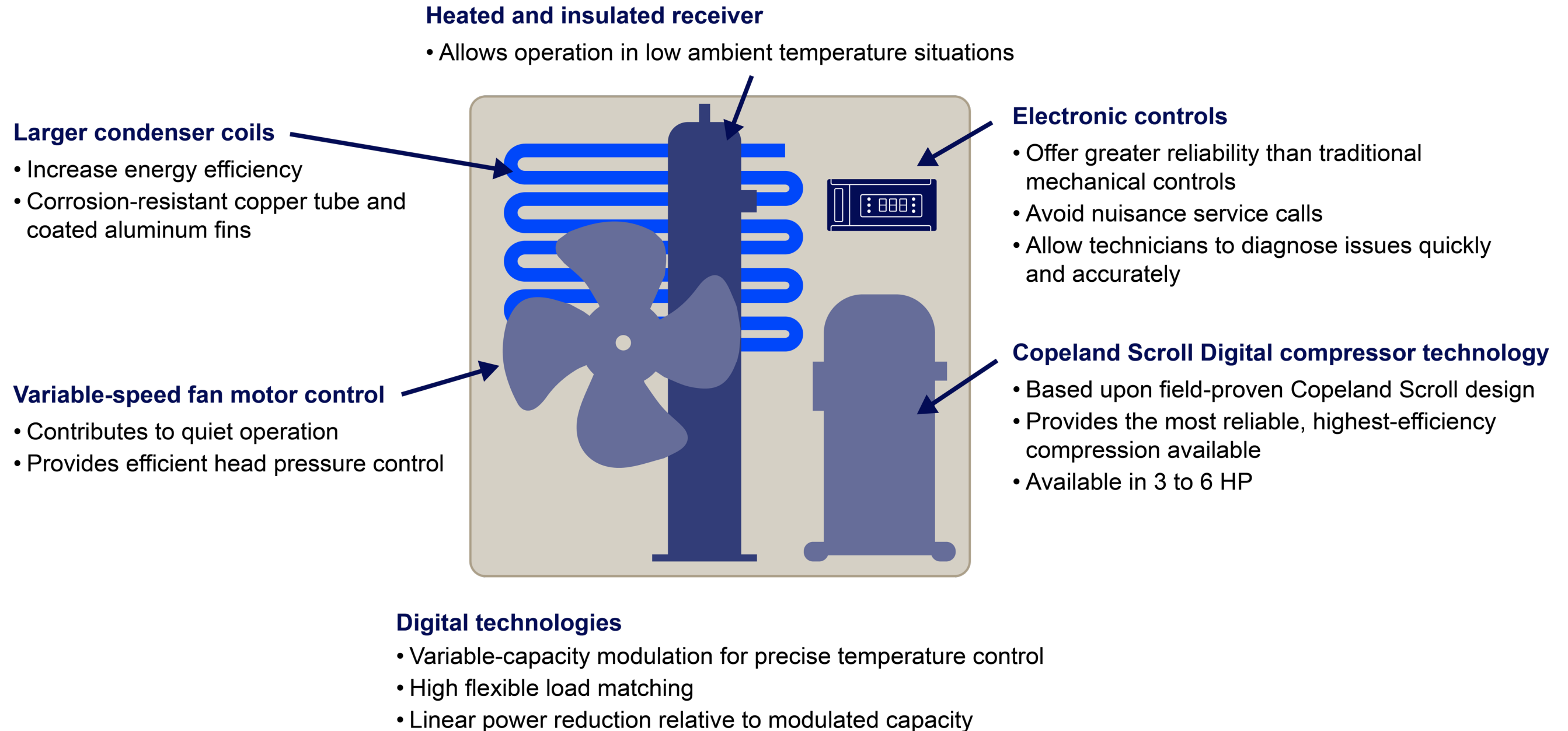

Copeland outdoor refrigeration unit, X-line series

Check out our entire line of X-Line series condensing units.

AWEF Approved ✓



Slim profile

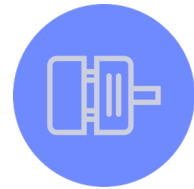

Connectivity



Quiet



Protection



Energy efficient



Visit <http://www.copeland.com/copelandoutdoorunit> to learn more.

COPELAND

Visit copeland.com/digitalxline for more information on our Copeland Digital Outdoor Refrigeration Unit, X-Line Series.