

# CC-100/CS-100

1. Connect CC-100 to a power module using output cable P/N 335-3258. If not using a Copeland power module, clip the connector from the cable, and wire based on the pinout shown below.
- 2a. If using a pulse valve, connect to the CC-100 using valve cable P/N 335-3263.
- 2b. If using a Sporlan SEI or Alco ESR stepper valve with four-pin connector, connect valve to CC-100/CS-100 using valve cable P/N 335-3261.
- 2c. If using a stepper with no four-pin connector, connect valve to CC-100/CS-100 using valve cable P/N 335-3260.
3. Wire the CC-100/CS-100 to Echelon network.

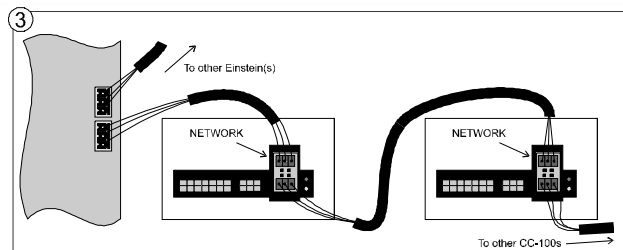
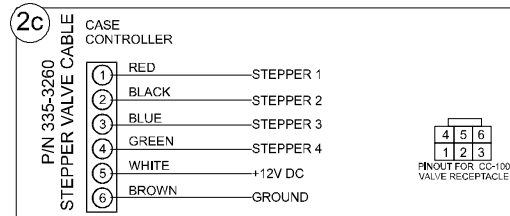
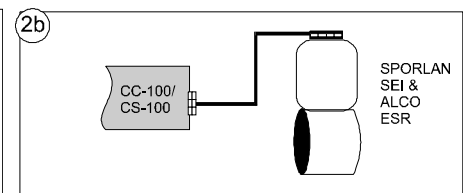
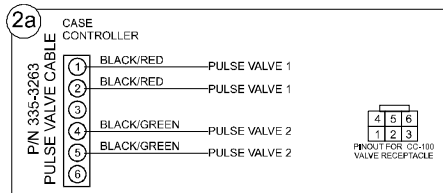
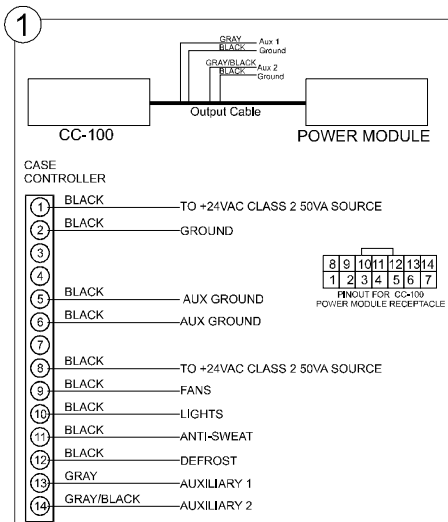
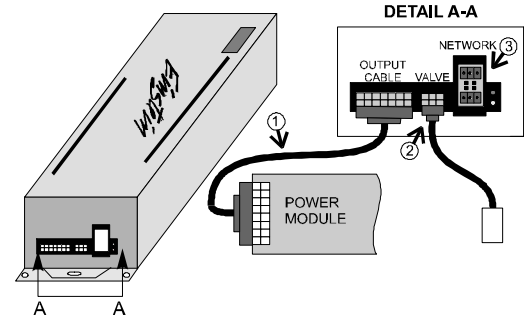

**NOTE:** This sheet is intended for use as a quick reference only. All installation technicians should read the installation and operation manuals for complete information.

Visit our website at [copeland.com/en-us/products/controls-monitoring-systems](http://copeland.com/en-us/products/controls-monitoring-systems) for the latest technical documentation and updates. For Technical Support call 833-409-7505 or email [ColdChain.TechnicalServices@Copeland.com](mailto:ColdChain.TechnicalServices@Copeland.com)