

Vission 20/20 micro-controller

Operation and service manual



VILTER™

EMERSON™
Climate Technologies

Table of Contents

Section Title	Section Number
How To Use This Manual.....	TOC-8
Section 1 • Operational Flow Charts	
Requirements to Start Compressor	1-1
Critical Compressor Run Logic at Compressor Start.....	1-1
Compressor Amperage Load Limiting	1-1
Figure 1-1. Operational Flow Charts	1-1
High Discharge Pressure Load Limiting.....	1-1
Suction Pressure Override Load Limit During Temperature Control	1-2
Section 2 • Installation Recommendations	
Proper Wiring Sizing	2-1
Voltage Source	2-1
Figure 2-1. Vission 20/20 with Individual Transformer	2-1
Figure 2-2. EMI and Vission 20/20	2-1
Grounding	2-2
Mixing Voltages	2-2
DC signals	2-2
Figure 2-3. Ground Wiring	2-2
Figure 2-4. Mixed Voltage Wiring.....	2-2
Wiring Methods.....	2-3
Figure 2-5. Correct Transformer Wiring Method	2-3
Figure 2-6. Incorrect Transformer Wiring Method	2-3
Best Practices.....	2-4
Section 3 • Hardware Architecture	
Overview	3-1
Figure 3-1. Hardware Architecture Overview	3-1
Digital Input/Output (I/O).....	3-2
Table 3-1. Digital I/O	3-3
Analog Inputs	3-4
Table 3-2. Analog Inputs.....	3-5
Analog Outputs	3-6
Digital & Analog I/O Boards Layout.....	3-6
Table 3-3. Analog Outputs.....	3-7
Figure 3-2. Digital I/O Board Layout.....	3-7
Digital Output Boards	3-8
Figure 3-3. Digital Output Board Layout	3-8
Digital Input Boards	3-9
Figure 3-4. Digital Input Board Layout	3-9
Digital In-Out Boards	3-10
Figure 3-5. Digital Input-Output Board Layout.....	3-10
Analog Input Boards	3-11
Figure 3-6. Analog Input Board Layout	3-11
Analog Input Jumper Tables	3-12
Table 3-4. Analog Input Jumper Tables.....	3-12
Analog Output Boards	3-14
Figure 3-6. Analog Output Board Layout	3-14

Table of Contents

Section Title	Section Number
Section 4 • Main Screen	
Overview	4-1
Figure 4-1. Digital I/O Board Layout.....	4-1
Top Status Bar	4-2
Figure 4-2. Top Status Bar	4-2
Parameter Bar	4-3
Figure 4-3. Parameter Bar	4-3
Figure 4-4. Unit Start Pop-Up Window	4-4
Bottom Status Bar	4-5
Figure 4-5. Bottom Status Bar	4-5
Splash Screen.....	4-6
Figure 4-6. Splash Screen	4-6
Section 5 • Menu Screen	
Overview	5-1
Navigation Buttons	5-1
Figure 5-1. Menu Screen	5-2
Section 6 • Compressor Control	
Overview	6-1
Pulse Proportional Control	6-1
Figure 6-1. Compressor Control Screen	6-1
Auto-Cycle	6-2
Figure 6-2. Proportional Band & Setpoint	6-2
Variable Frequency Drive (VFD).....	6-3
Figure 6-3. VFD One-Step Control Method	6-3
Figure 6-4. VFD Two-Step Control Method	6-3
Pumpdown Control.....	6-4
Pulldown Control	6-5
Control Mode.....	6-6
Stop load & Force unload	6-6
Capacity Slide Triggered Outputs	6-6
Volume Slide Position Offset	6-6
Soft Load	6-6
Load Anticipating.....	6-7
Oil Control	6-7
Liquid Injection	6-7
Section 7 • Alarms and Trips	
Overview	7-1
Alarms and Trips Setpoints.....	7-1
Figure 7-1. Alarms and Trips Screen.....	7-1
Compressor Inhibits.....	7-3
Safety Failure Messages	7-3
Section 8 • Timers	
Overview	8-1
Timer Setpoints	8-1
Figure 8-1. Timers Screen.....	8-1
Section 9 • Compressor Scheduling	
Overview	9-1
Scheduling Setpoint.....	9-1
Figure 9-1. Compressor Scheduling Screen	9-1

Table of Contents

Section Title	Section Number
Section 10 • Compressor Sequencing	
Overview	10-1
Pressure Control Setpoints.....	10-1
Figure 10-1. Compressor Sequencing Screen	10-1
Section 11 • Condenser Control	
Overview	11-1
Condenser Control Setpoint.....	11-1
Figure 11-1. Condenser Control Screen	11-1
Step Control.....	11-2
Figure 11-2. Step Control Screen.....	11-3
VFD Settings.....	11-3
Section 12 • Service Options	
Overview	12-1
Digital Outputs	12-1
Figure 12-1. Service Options Screen.....	12-1
Analog Outputs	12-2
Section 13 • Instruments Calibration	
Overview	13-1
Pressure and Temperature Inputs.....	13-1
Figure 13-1. Instruments Calibration Screen	13-1
Motor Current.....	13-2
Remote Capacity	13-2
Analog Inputs	13-2
Section 14 • Slide Calibration	
Overview	14-1
Capacity Slide Valve Potentiometer.....	14-1
Figure 14-1. Slide Calibration Screen.....	14-1
Volume Slide Valve Potentiometer	14-2
Slide Valve Operation.....	14-2
Slide Valve Actuator Calibration for Optical Style Motors.....	14-2
Figure 14-2. Photochopper	14-3
Command Shaft Rotation.....	14-4
Table 14-1. Command Shaft Rotation Required By Actuator.....	14-4
Slide Valve Troubleshooting Guide	14-5
Table 14-2. Slide Valve Troubleshooting Guide	14-5
Slide Valve Actuator Troubleshooting Guide Blink Code	14-7
Table 14-3. LED Blink Codes and Troubleshooting Guide.....	14-7
Section 15 • Trend Chart	
Overview	15-1
Chart Operation.....	15-1
Figure 15-1. Trend Chart Screen.....	15-1
Trend Data Storage	15-2
Setup.....	15-3
Figure 15-2. Trend Setup Screen.....	15-3

Table of Contents

Section Title	Section Number
Section 16 • Event List	
Overview	16-1
Event list Columns.....	16-1
Figure 16-1. Event List Screen.....	16-1
Section 17 • Input / Output	
Overview	17-1
Figure 17-1. Input/Output Screen	17-1
Section 18 • Auxiliary Input / Output	
Overview	18-1
Digital Inputs	18-1
Figure 18-1. Auxiliary Input/Output Screen	18-1
Digital Outputs	18-2
Analog Inputs	18-2
Analog Outputs	18-3
Control	18-3
Section 19 • Configuration	
Overview	19-1
Units.....	19-1
Time & Date.....	19-1
Figure 19-1. Configuration Screen - Page 1.....	19-1
Communications	19-2
Touchscreen	19-2
Anti-Recycle.....	19-2
Restart On Power Failure.....	19-3
Compressor Sequencing	19-3
Language.....	19-3
Model & Refrigerant.....	19-3
Figure 19-2. Configuration Screen - Page 2.....	19-4
Compressor Control.....	19-4
Optional Function Selection	19-4
Condenser Control.....	19-5
Oil Pump.....	19-5
Oil Cooling.....	19-5
Motor Current Device	19-5
Figure 19-3. Configuration Screen - Page 3.....	19-6
Digital Inputs	19-6
Analog Inputs	19-7
Figure 19-4. Configuration Screen - Page 4.....	19-7
Figure 19-5. Configuration Screen - Page 5.....	19-8
Analog Outputs	19-8
Digital Outputs	19-8
I/O Configuration.....	19-9
Figure 19-6. Configuration Screen - Page 6.....	19-9

Table of Contents

Section Title	Section Number
Section 20 • Data Backup	
Overview	20-1
Save / Load.....	20-1
Figure 20-1. Data Backup Screen - Save/Load	20-1
Migrate.....	20-3
Factory Reset	20-3
Figure 20-2. Data Backup Screen - Migrate and Factory Reset.....	20-3
Section 21 • Maintenance	
Overview	21-1
Checklist.....	21-1
Figure 21-1. Maintenance Screen	21-1
Notes.....	21-2
Log	21-2
Chart	21-2
Section 22 • User Access	
Overview	22-1
Apply	22-1
Figure 22-1. User Access Screen - Login	22-1
Figure 22-2. User Access Screen - Manage Accounts	22-2
Login	22-2
Manage Accounts	22-2
Screen Security Levels	22-3
Table 22-1. Security Access Levels	22-3
Section 23 • Help Screen	
Overview	23-1
Screen Features:.....	23-1
Figure 23-1. Help Screen	23-1
Figure 23-2. Version Pop-Up Screen	23-2
Section 24 • Twin Screw Control	
Overview	24-1
Setup.....	24-1
Figure 24-1. Twin Screw Control Screen	24-1
Operation	24-2
Section 25 • Cool Compression Control	
Overview	25-1
Setup.....	25-1
Figure 25-1. Cool Compression Control Screen.....	25-1
Figure 25-2. Cool Compression Control Functions Screen.....	25-2
Control Functions	25-2
Operational Differences from Single Screw	25-3

List of Tables and Figures

Table/Figure	Page Number
Table 3-1. Digital I/O	3-3
Table 3-2. Analog Inputs.....	3-5
Table 3-3. Analog Outputs.....	3-7
Table 3-4. Analog Input Jumper Tables.....	3-12
Table 14-1. Command Shaft Rotation Required By Actuator	14-4
Table 14-2. Slide Valve Troubleshooting Guide	14-5
Table 14-3. LED Blink Codes and Troubleshooting Guide.....	14-7
Table 22-1. Security Access Levels	22-3
Figure 1-1. Operational Flow Charts	1-1
Figure 2-1. Vission 20/20 with Individual Transformer	2-1
Figure 2-2. EMI and Vission 20/20	2-1
Figure 2-3. Ground Wiring	2-2
Figure 2-4. Mixed Voltage Wiring	2-2
Figure 2-5. Correct Transformer Wiring Method	2-3
Figure 2-6. Incorrect Transformer Wiring Method	2-3
Figure 3-1. Hardware Architecture Overview	3-1
Figure 3-2. Digital I/O Board Layout.....	3-7
Figure 3-3. Digital Output Board Layout.....	3-8
Figure 3-4. Digital Input Board Layout	3-9
Figure 3-5. Digital Input-Output Board Layout.....	3-10
Figure 3-6. Analog Input Board Layout	3-11
Figure 3-7. Analog Output Board Layout	3-14
Figure 4-1. Digital I/O Board Layout.....	4-1
Figure 4-2. Top Status Bar	4-2
Figure 4-3. Parameter Bar	4-3
Figure 4-4. Unit Start Pop-Up Window	4-4
Figure 4-5. Bottom Status Bar	4-5
Figure 4-6. Splash Screen	4-6
Figure 5-1. Menu Screen	5-2
Figure 6-1. Compressor Control Screen	6-1
Figure 6-2. Proportional Band & Setpoint.....	6-2
Figure 6-3. VFD One-Step Control Method	6-3
Figure 6-4. VFD Two-Step Control Method	6-3
Figure 7-1. Alarms and Trips Screen.....	7-1
Figure 8-1. Timers Screen.....	8-1
Figure 9-1. Compressor Scheduling Screen	9-1
Figure 10-1. Compressor Sequencing Screen	10-1
Figure 11-1. Condenser Control Screen	11-1
Figure 11-2. Step Control Screen.....	11-3
Figure 12-1. Service Options Screen.....	12-1
Figure 13-1. Instruments Calibration Screen	13-1
Figure 14-1. Slide Calibration Screen.....	14-1
Figure 14-2. Photochopper	14-3
Figure 15-1. Trend Chart Screen.....	15-1
Figure 15-2. Trend Setup Screen.....	15-3
Figure 16-1. Event List Screen.....	16-1
Figure 17-1. Input/Output Screen	17-1
Figure 18-1. Auxiliary Input/Output Screen	18-1
Figure 19-1. Configuration Screen - Page 1.....	19-1
Figure 19-2. Configuration Screen - Page 2.....	19-4
Figure 19-3. Configuration Screen - Page 3.....	19-6

List of Tables and Figures

Table/Figure	Page Number
Figure 19-4. Configuration Screen - Page 4.....	19-7
Figure 19-5. Configuration Screen - Page 5.....	19-8
Figure 19-6. Configuration Screen - Page 6.....	19-9
Figure 20-1. Data Backup Screen - Save/Load	20-1
Figure 20-2. Data Backup Screen - Migrate and Factory Reset.....	20-3
Figure 21-1. Maintenance Screen	21-1
Figure 22-1. User Access Screen - Login	22-1
Figure 22-2. User Access Screen - Manage Accounts	22-2
Figure 23-1. Help Screen	23-1
Figure 23-2. Version Pop-Up Screen	23-2
Figure 24-1. Twin Screw Control Screen	24-1
Figure 25-1. Cool Compression Control Screen.....	25-1
Figure 25-2. Cool Compression Control Functions Screen.....	25-2

How to Use This Manual

This manual contains instructions for the Vission 20/20 Operation & Service Manual. It has been divided into 25 sections.

- Section 1: Operational Flow Charts
- Section 2: Installation Recommendations
- Section 3: Hardware Architecture
- Section 4: Main Screen
- Section 5: Menu Screen
- Section 6: Compressor Control
- Section 7: Alarms & Trips
- Section 8: Timers
- Section 9: Compressor Scheduling
- Section 10: Compressor Sequencing
- Section 11: Condensor Control
- Section 12: Service Options
- Section 13: Instruments Calibration
- Section 14: Slide Calibration
- Section 15: Trend Chart
- Section 16: Event List
- Section 17: Input/Output
- Section 18: Auxiliary Input/Output
- Section 19: Configuration
- Section 20: Data Backup
- Section 21: Maintenance
- Section 22: User Access
- Section 23: Help Screen
- Section 24: Twin Screw Control
- Section 25: Cool Compression Control

It is highly recommended that the manual be reviewed prior to servicing the Vission 20/20 system parts.

Figures and tables are included to illustrate key concepts.

Safety precautions are shown throughout the manual. They are defined as the following:

WARNING - Warning statements are shown when there are hazardous situations, if not avoided, will result in serious injury or death.

CAUTION - Caution statements are shown when there are potentially hazardous situations, if not avoided, will result in damage to equipment.

NOTE - Notes are shown when there are additional information pertaining to the instructions explained.

NOTICE - Notices are shown when there are important information that can help avoid system failure.

For additional information pertaining to the Vission 20/20, refer to www.Vission2020.net/documents. Information that can be found on the site are:

- Manuals
- Release Advisories
- Application Notes
- Videos

Section 1 • Operational Flow Charts

Requirements to Start Compressor

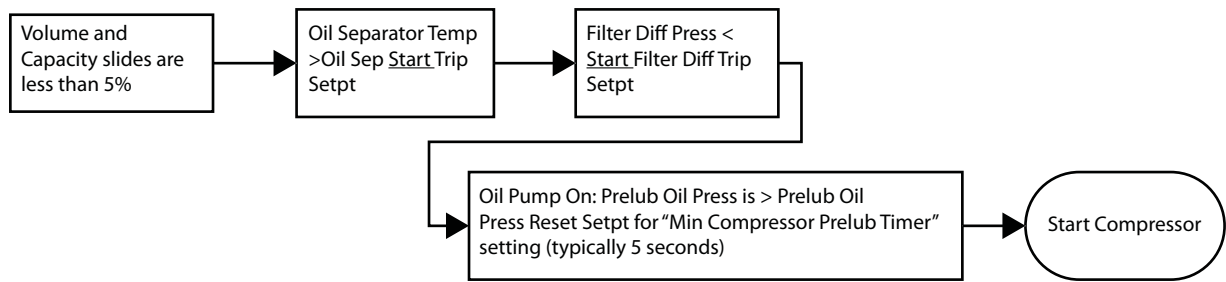

Critical Compressor Run Logic at Compressor Start

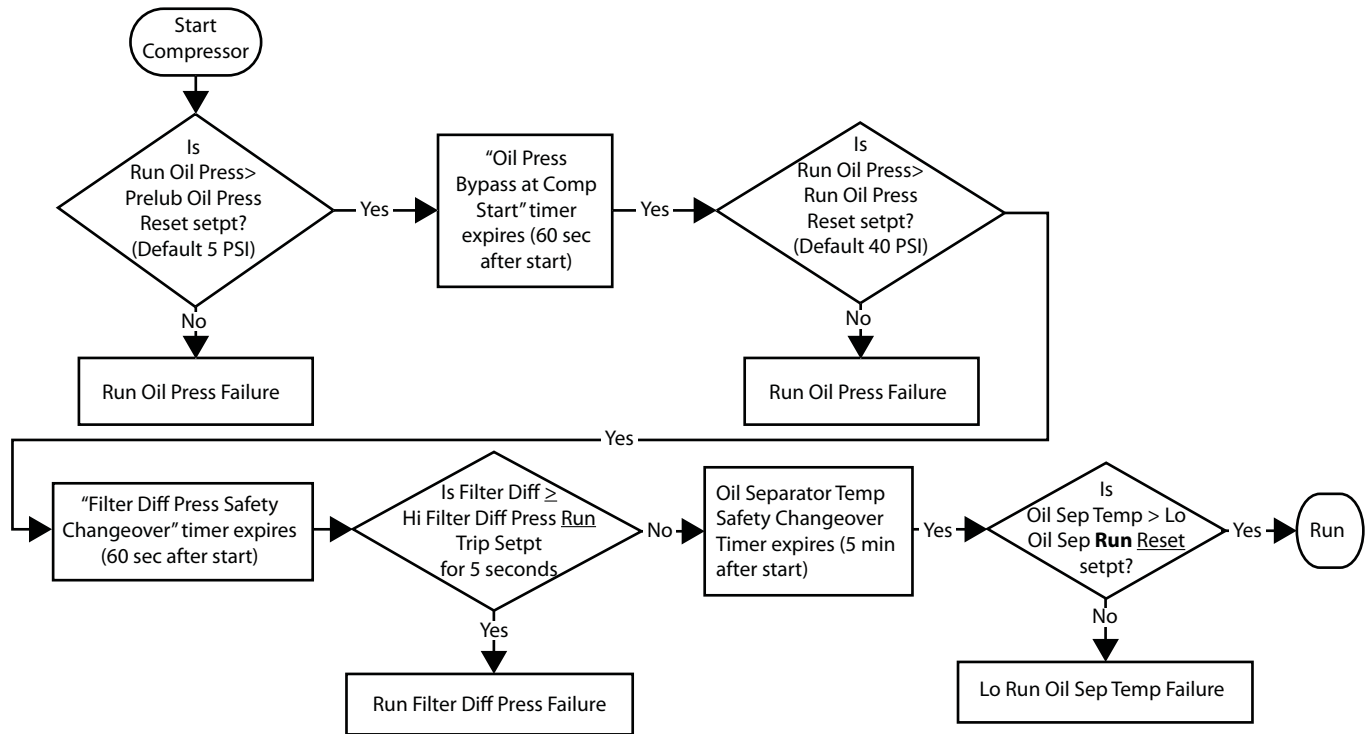

Compressor Amperage Load Limiting

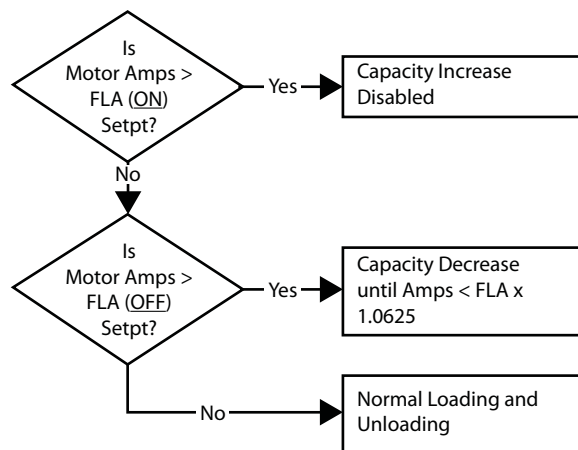

High Discharge Pressure Load Limiting

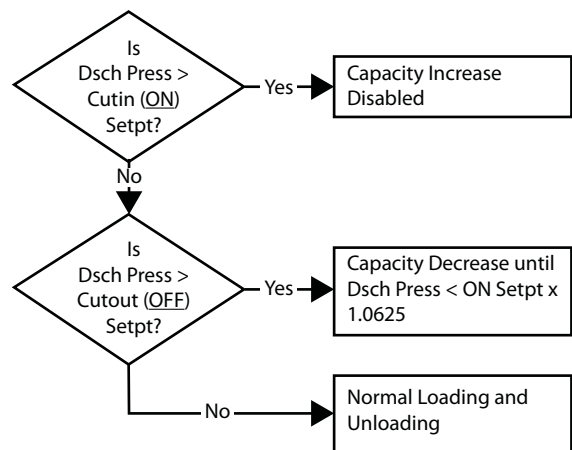

Figure 1-1. Operational Flow Charts (1 of 2)

Section 1 • Operational Flow Charts

Suction Pressure Override Load Limit During Temperature Control

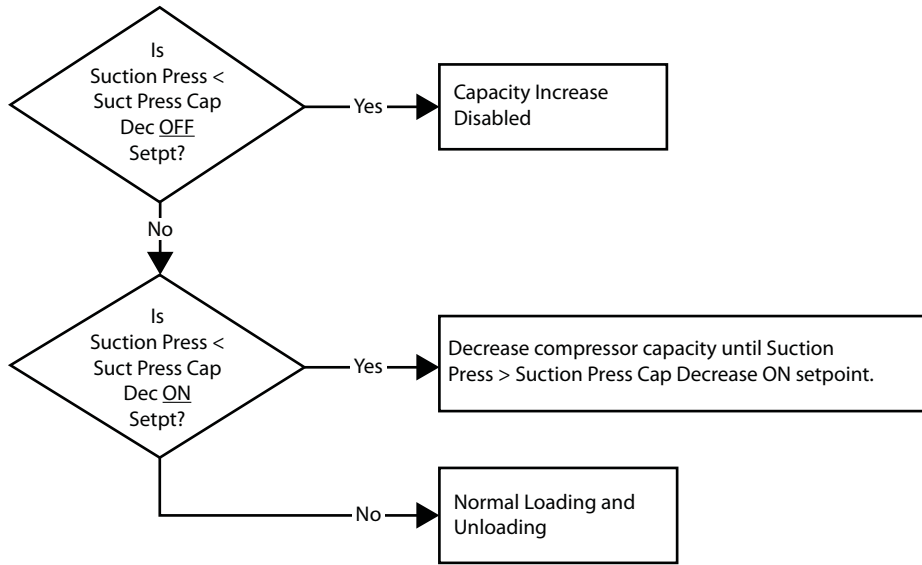

Figure 1-1. Operational Flow Charts (2 of 2)

Section 2 • Installation Recommendations

Proper Wiring Sizing

- Always size wire gauges as specified by the National Electrical Code (NEC) for electronic control devices.
- For improved noise immunity, install one size larger wire gauge than the NEC requirement to assure ample current-carrying capability.
- Never under size wire gauges.

Voltage Source

- Transformers block a large percentage of

Electro-Magnetic Interference (EMI). The Vilter Vision 20/20 should be isolated with its own control transformer for the most reliable operation, see Figure 2-1. Vision 20/20 with Individual Transformer.

- Connecting the Vilter Vision 20/20 to breaker panels and central control transformers exposes the Vision 20/20 to large amounts of EMI emitted from the other devices connected to the secondary terminals of the transformer. This practice should be avoided if possible, see Figure 2-2. EMI and Vision 20/20.

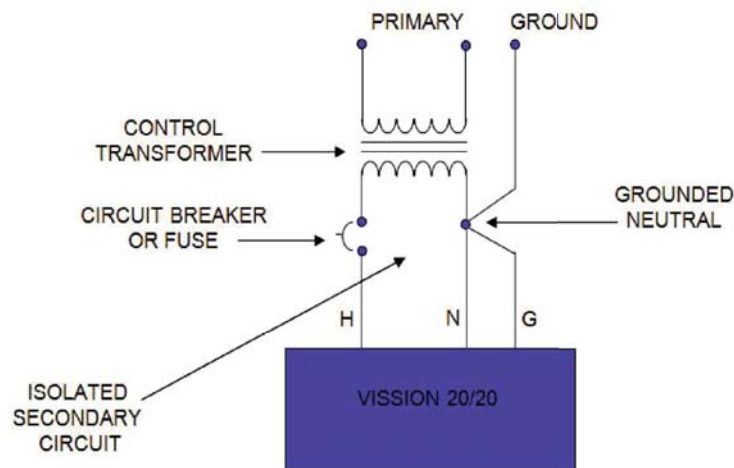

Figure 2-1. Vision 20/20 with Individual Transformer

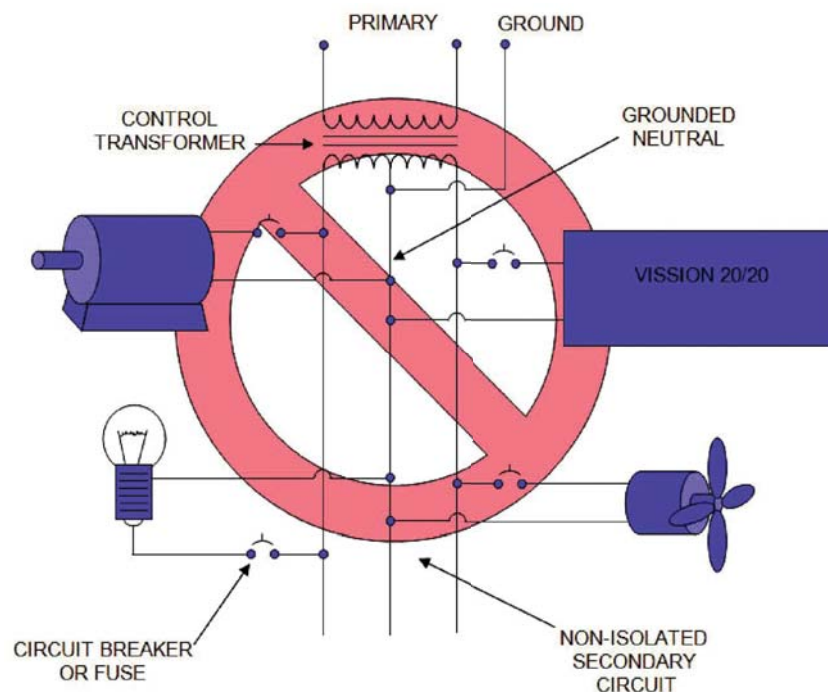

Figure 2-2. EMI and Vision 20/20

Section 2 • Installation Recommendations

Grounding

- Continuous grounds must be run from the utility ground to the Vision 20/20, see Figure 2-3. Grounding.
- Grounds must be copper or aluminum wire.
- Never use conduit grounds.

Each voltage level must be run in separate conduit:

- 460 VAC
- 230 VAC
- 120 VAC
- 24 VAC

Mixing Voltages

- Separate different voltages from each other and separate AC from DC, see Figure 2-4. Mixed Voltage Wiring.

DC signals

- If your installation site has wire-ways or conduit trays, dividers must be installed between the different voltages.

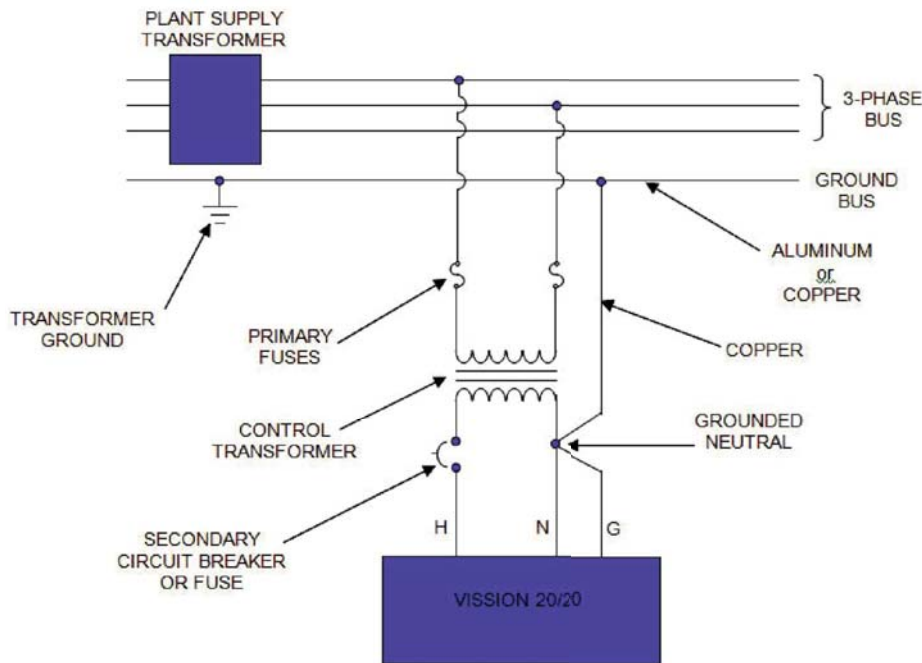

Figure 2-3. Ground Wiring

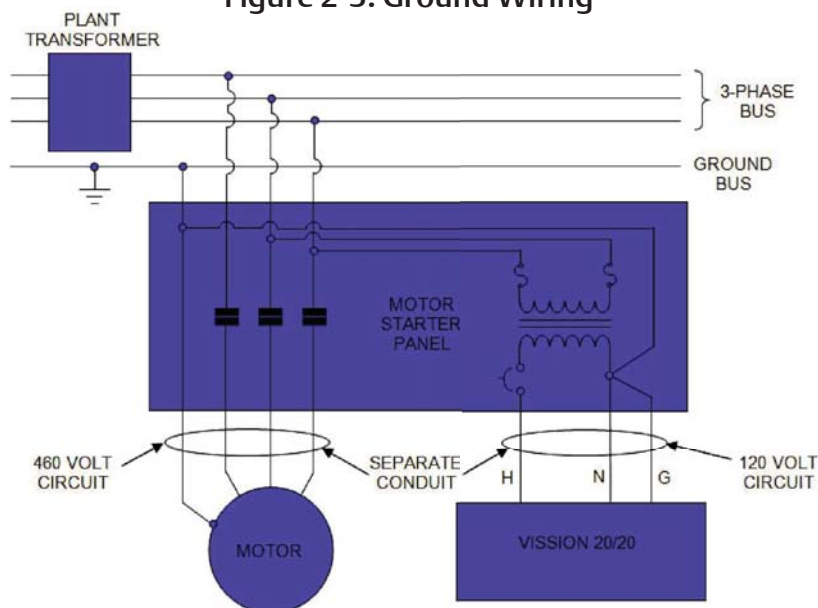

Figure 2-4. Mixed Voltage Wiring

Section 2 • Installation Recommendations

Wiring Methods

- Each Vission 20/20 panel should have its own individual control transformer, see Figure 2-5. Correct Transformer Wiring Method and Figure 2-6. Incorrect Transformer Wiring Method.

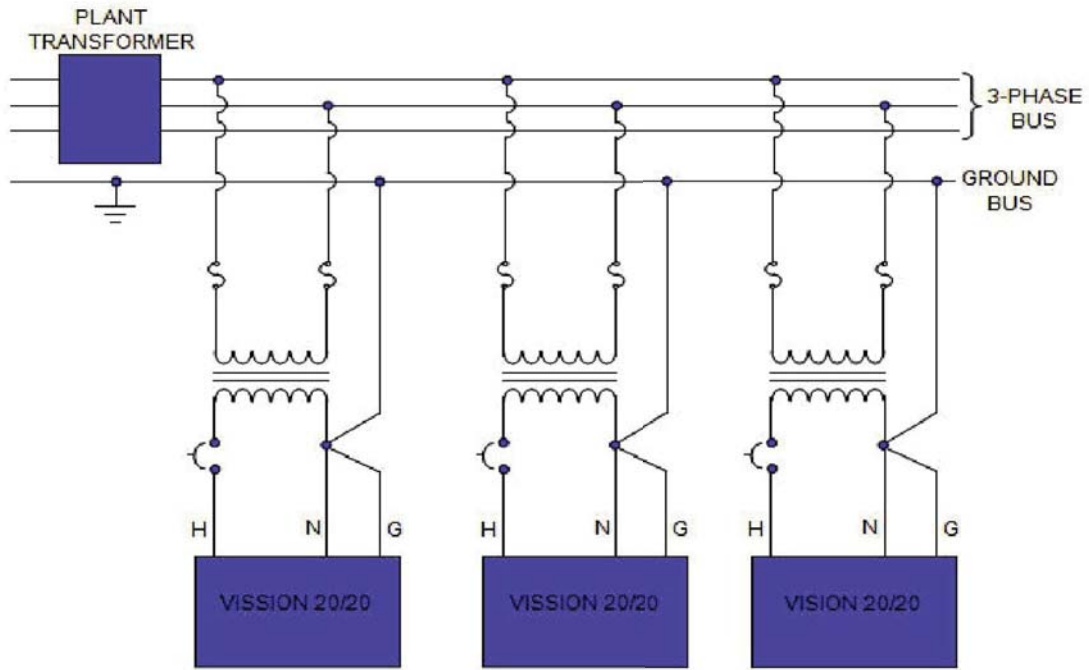

Figure 2-5. Correct Transformer Wiring Method

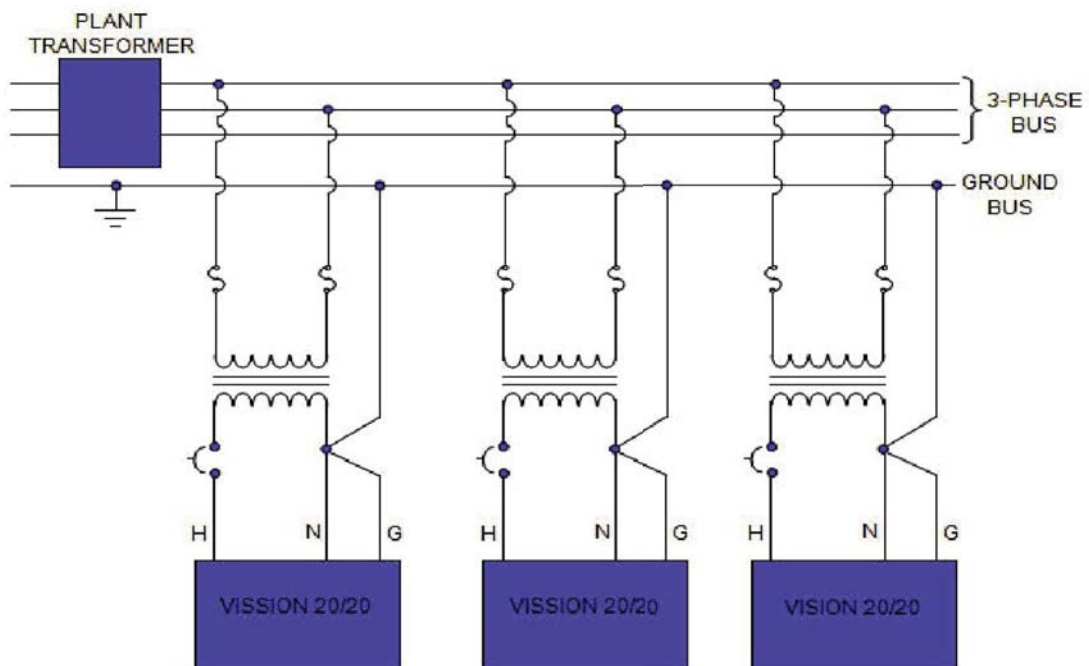

Figure 2-6. Incorrect Transformer Wiring Method

Section 2 • Installation Recommendations

Best Practices

- Do:
 - Keep AC wires away from circuit boards.
 - Always run conduit into the bottom or sides of an enclosure.
 - If the conduit must be placed in the top of an enclosure, use a water-tight conduit fitting to keep water from entering the enclosure.
 - The Vission 20/20 is supplied with pre-punched conduit holes. Use them!
- Don't:
 - Don't run wires through the Vission 20/20 enclosure that are not related to the compressor control.
 - Don't add relays, timers, transformers, etc. in the Vission 20/20 enclosure without first checking with Vilter.
 - Don't run conduit into the top of an enclosure.
 - Don't run refrigerant tubing inside the enclosure.
 - Don't drill metal enclosures without taking proper precautions to protect circuit boards from damage.

Section 3 • Hardware Architecture

Overview

The Vission 20/20 control panel utilizes X-86 PC technology with a Linux operating system. For hardware architecture, see Figure 3-1 Hardware Architecture Overview.

The Vission 20/20 has the following attributes:

- Low power, Industrial rated X-86 CPU.
- 15" XGA, high resolution LCD display. (Outdoor viewable LCD optional).
- 8-wire touch screen operator interface.
- Flexible and expandable I/O.
- NEMA-4 enclosure (NEMA-4X optional).
- Industrial temperature range design.

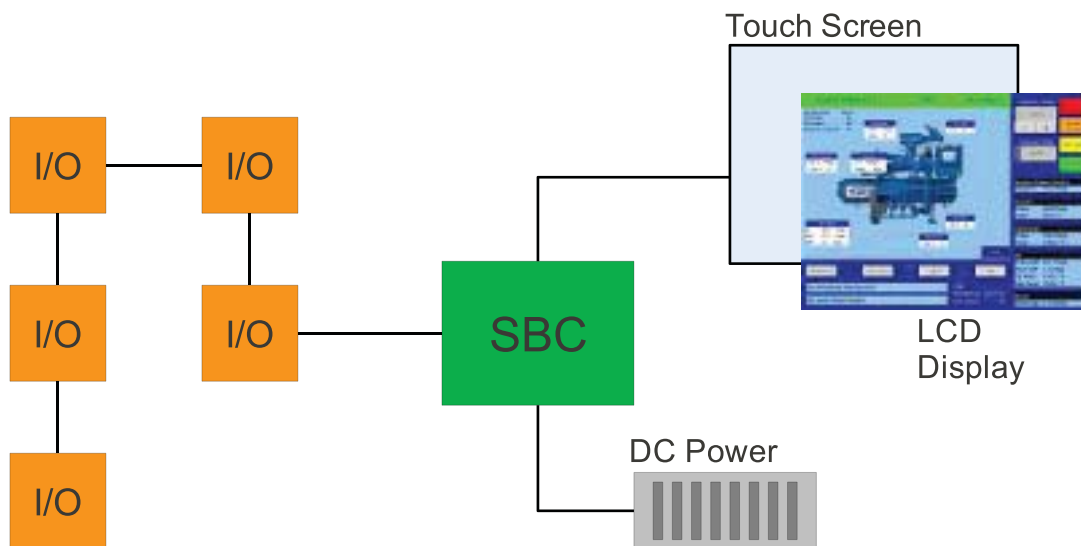

Figure 3-1. Hardware Architecture Overview

Section 3 • Hardware Architecture

Digital Input/Output (I/O)

Refer to Table 2-1. Digital I/O.

Compressor Start Output:

- When the Vission 20/20 signals the compressor to start, this output is energized. When the Vission 20/20 signals the compressor to stop, this output is de-energized.

Oil Pump Start Output:

- When the Vission 20/20 signals the oil pump to start, this output is energized. When the Vission 20/20 signals the oil pump to stop, this output is de-energized.

Capacity Increase Output:

- This output is only active when the compressor is running. When the Vission 20/20 determines that the compressor should increase capacity by moving the slide valve to a higher percentage, this output is energized. Once the slide valve reaches 100%, this output will not energize.

Capacity Decrease Output:

- This output is only active when the compressor is running. When the Vission 20/20 determines that the compressor should decrease capacity by moving the slide valve to a lower percentage, this output is energized. Once the slide valve reaches 0%, this output will not energize.

Volume Increase Output:

- This output is only active when the compressor is running. When the Vission 20/20 determines that the compressor should increase Volume Index (VI) by moving the volume slide to a higher percentage, this output is energized. Once the volume slide reaches 100%, this output will not energize.

Volume Decrease Output:

- This output is only active when the compressor is running. When the Vission 20/20 determines that the compressor should decrease Volume Index (VI) by moving the volume slide to a lower percentage, this output is energized. Once the volume slide reaches 0%, this output will not energize.

Oil Sump Heater Output:

- This output is active and energized when the oil separator temperature is lower than the oil separator temperature setpoint. It is de-energized when the oil separator temperature is higher than the oil separator temperature setpoint.

Trip Output:

- This output is energized when the system has no Trips. If a trip is issued, the output de-energizes and stays de-energized until the trip condition is cleared.

Slide Valve Setpoint #1 Output (Economizer):

- Normally used for an economizer solenoid, but could be used for other devices. When the compressor slide valve percentage is equal to or greater than “slide valve set-point #1”, the output is energized. When the compressor slide valve percentage is less than “slide valve set-point #1”, the output is de-energized.

Slide Valve Setpoint #2 Output (Hot Gas):

- Normally used for a hot gas solenoid, but could be used for other devices. When the compressor slide valve percentage is equal to or greater than “slide valve set-point #2”, the output is energized. When the compressor slide valve percentage is less than “slide valve set-point #2”, the output is de-energized.

Alarm Output:

- This output is energized when the system has no alarms. If an alarm is issued, the output de-energizes and stays de-energized until the alarm condition is cleared.

Unused:

- This output has no current function.

Liquid Injection #1 Output:

- If the compressor has liquid injection oil cooling, this output is active. When the compressor is running and the discharge temperature is above the oil separator temperature override setpoint and the oil separator temperature is above the override setpoint, then the output is energized. The output is de-energized when the discharge temperature falls below the “on” setpoint minus the solenoid differential.

Liquid Injection #2 Output:

- Not Defined

Remote Enabled Output:

- This output is energized when the Vission 20/20 panel is enabled for remote control. The compressor can be running or stopped, but is available to the remote system. If the compressor has an alarm or is placed into the manual stop position, this output is de-energized.

Shunt Trip:

- Not defined.

Comp Motor Starter Auxiliary Contact:

- This input looks for a feedback signal from the compressor starter, confirming that the compressor starter is energized.

Section 3 • Hardware Architecture

Table 3-1. Digital I/O (1 of 2)

Board	I/O #	Description	Type
1	1	Compressor Start	OUTPUT
1	2	Oil Pump Start	OUTPUT
1	3	Capacity Increase	OUTPUT
1	4	Capacity Decrease	OUTPUT
1	5	Volume Increase	OUTPUT
1	6	Volume Decrease	OUTPUT
1	7	Oil Separator Heater	OUTPUT
2	8	Trip indicator (ON=Normal)	OUTPUT
2	9	Slide Valve Set point #1 (Economizer)	OUTPUT
2	10	Slide Valve Set point #2 (Hot Gas)	OUTPUT
2	11	Alarm	OUTPUT
2	12	Unused	OUTPUT
2	13	Liquid Injection #1	OUTPUT
2	14	Liquid Injection #2	OUTPUT
2	15	Remote Enabled	OUTPUT
2	16	Shunt Trip	OUTPUT
3	17	Comp Motor Starter Auxiliary Contact	INPUT
3	18	High Level Shutdown	INPUT
3	19	Oil Level Float Switch #1	INPUT
3	20	Oil Level Float Switch #2	INPUT
3	21	Remote Setpoint #1/#2 Selection	INPUT
3	22	Remote Start/Stop	INPUT
3	23	Remote Capacity Increase	INPUT
3	24	Remote Capacity Decrease	INPUT
4	25	Condenser Step #1	OUTPUT
4	26	Condenser Step #2	OUTPUT
4	27	Condenser Step #3	OUTPUT
4	28	Condenser Step #4	OUTPUT
4	29	Auxiliary Input #1	INPUT
4	30	Auxiliary Input #2	INPUT
4	31	Auxiliary Input #3	INPUT
4	32	Auxiliary Input #4	INPUT

Section 3 • Hardware Architecture

High Level Shutdown Input:

- This input must be energized in order for the compressor to operate. If de-energized, the compressor will shut down and issue a high level trip.

Oil Level Float Switch #1 Input:

- Used for Cool Compression.

Oil Level Float Switch #2 Input:

- Used for Cool Compression.

Remote Select #1/#2 Input:

- This input enables or disables remote I/O control. Energizing this input enables the Remote Capacity Increase and Remote Capacity Decrease inputs.

Remote Start/Stop Input:

- If the compressor is enabled for remote I/O control, this input is enabled. Energizing this input will issue a start for the compressor as long as it is available to run. De-energizing this input stops the compressor.

Remote Capacity Increase Input:

NOTE

The scan interval on the remote increase and decrease inputs is approximately ONE SECOND. Please take that into account when developing a control scheme using the remote increase and remote decrease inputs for compressor control.

- If the compressor is enabled for remote I/O control, this input is enabled. Operational only when the compressor is running. Energizing this input will increase the slide valve position.
- The slide valve will continuously increase as long as this input is energized. The slide valve will not increase when this input is de-energized.

Remote Capacity Decrease Input:

- Operational only when the compressor is running. This input is enabled if the compressor is enabled for remote I/O control. Energizing this input will decrease the slide valve position. The slide valve will continuously decrease as long as this input is energized. The slide valve will not decrease when this input is de-energized.

Condenser Step #1 Output:

- This output is enabled when condenser control option is selected. A condenser fan or pump will be turned on or off by this output.

Condenser Step #2 Output:

- This output is enabled when condenser control option is selected. A condenser fan or pump will be turned on or off by this output.

Condenser Step #3 Output:

- This output is enabled when condenser control option is selected. A condenser fan or pump will be turned on or off by this output.

Condenser Step #4 Output:

- This output is enabled when condenser control option is selected. A condenser fan or pump will be turned on or off by this output.

Auxiliary Inputs #1 - #8:

- Optional inputs that can be configured as an alarm or trip. Typically connected to external switched devices.

Auxiliary Outputs #1 - #4:

- Optional outputs that can be configured as an alarm or trip. Typically connected to external switched devices.

Analog Inputs

Refer to Table 2-2. Analog Inputs.

Motor Current:

- Default is a 0-5 Amp current transformer (CT). Current transformer ratio is set in the calibration screen.

Suction Pressure:

- Default signal is 4-20mA. Suction pressure transducer range and calibration is set in the calibration screen.

Discharge Pressure

- Default signal is 4-20mA. Discharge pressure transducer range and calibration is set in the calibration screen.

Oil Filter Inlet Pressure:

- Default signal is 4-20mA. Oil filter pressure transducer range and calibration is set in the calibration screen.

Oil Manifold Pressure:

- Default signal is 4-20mA. Oil manifold pressure transducer range and calibration is set in the calibration screen.

Economizer Pressure:

- Default signal is 4-20mA. Economizer pressure transducer range and calibration is set in the calibration screen.

Slide Valve Position:

- Reads the 0-5 volt signal back from the slide position motor actuator to indicate current slide valve position.

Section 3 • Hardware Architecture

Table 3-1. Digital I/O (2 of 2)

Board	I/O #	Description	Type
5	33	Auxiliary Output #1	OUTPUT
5	34	Auxiliary Output #2	OUTPUT
5	35	Auxiliary Output #3	OUTPUT
5	36	Auxiliary Output #4	OUTPUT
5	37	Auxiliary Input #5	INPUT
5	38	Auxiliary Input #6	INPUT
5	39	Auxiliary Input #7	INPUT
5	40	Auxiliary Input #8	INPUT

Table 3-2. Analog Inputs (1 of 2)

Board	I/O #	Description	Type
6	1	Motor Current	4-20 mA, 0-5A
6	2	Suction Pressure	0-5V, 1-5 V, 0-10V, 4-20 mA
6	3	Discharge Pressure	0-5V, 1-5 V, 0-10V, 4-20 mA
6	4	Oil Filter Inlet Pressure	0-5V, 1-5 V, 0-10V, 4-20 mA
6	5	Oil Manifold Pressure	0-5V, 1-5 V, 0-10V, 4-20 mA
6	6	Economizer Pressure	0-5V, 1-5 V, 0-10V, 4-20 mA
6	7	% Slide Valve Position	0-5V, 4-20 mA, Potentiometer
6	8	% Volume Position	0-5V, 4-20 mA, Potentiometer
7	9	Suction Temperature	4-20 mA, RTD, ICTD
7	10	Discharge Temperature	4-20 mA, RTD, ICTD
7	11	Oil Separator Temperature	4-20 mA, RTD, ICTD
7	12	Oil Manifold Temperature	4-20 mA, RTD, ICTD
7	13	Process Temperature	4-20 mA, RTD, ICTD
7	14	Chiller Inlet Temperature	4-20 mA, RTD, ICTD
7	15	Condenser Pressure	0-5V, 1-5 V, 0-10V, 4-20 mA, RTD, ICTD
7	16	Remote Caphold Setpoint	0-5V, 4-20 mA, RTD, ICTD
8	17	Auxiliary #1	0-5V, 1-5 V, 0-10V, 4-20 mA, RTD, ICTD
8	18	Auxiliary #2	0-5V, 1-5 V, 0-10V, 4-20 mA, RTD, ICTD
8	19	Auxiliary #3	0-5V, 1-5 V, 0-10V, 4-20 mA, RTD, ICTD
8	20	Auxiliary #4	0-5V, 1-5 V, 0-10V, 4-20 mA, RTD, ICTD
8	21	Auxiliary #5	0-5V, 1-5 V, 0-10V, 4-20 mA, RTD, ICTD
8	22	Auxiliary #6	0-5V, 1-5 V, 0-10V, 4-20 mA, RTD, ICTD
8	23	Auxiliary #7	0-5V, 1-5 V, 0-10V, 4-20 mA, RTD, ICTD
8	24	Auxiliary #8	0-5V, 1-5 V, 0-10V, 4-20 mA, RTD, ICTD
9	25	Auxiliary #9	0-5V, 1-5 V, 0-10V, 4-20 mA, RTD, ICTD
9	26	Auxiliary #10	0-5V, 1-5 V, 0-10V, 4-20 mA, RTD, ICTD
9	27	Auxiliary #11	0-5V, 1-5 V, 0-10V, 4-20 mA, RTD, ICTD

Section 3 • Hardware Architecture

Volume Position:

- Reads the 0-5 volt signal back from the slide volume motor actuator to indicate current volume position.

Suction Temperature:

- Default signal is RTD. Suction temperature calibration is set in the calibration screen.

Discharge Temperature:

- Default signal is RTD. Discharge temperature calibration is set in the calibration screen.

Oil Separator Temperature:

- Default signal is RTD. Oil separator temperature calibration is set in the calibration screen.

Oil Manifold Temperature:

- Default signal is RTD. Oil manifold temperature calibration is set in the calibration screen.

Process Temperature:

- Default signal is 4-20mA. Process temperature calibration and range are set in the calibration screen.

Chiller Inlet Temperature:

- Default signal is 4-20mA. Measures separator level. Chiller Inlet Temperature calibration and range are set in the calibration screen.

Condenser Pressure:

- Default signal is 4-20mA. Condenser pressure transducer range and calibration is set in the calibration screen.

Remote Caphold:

- Default signal is 4-20mA. Active in “Direct I/O” mode. Adjusts the capacity of the compressor from 0-100%, proportional to the 4-20mA signal.

Auxiliary #1 - #16:

- Flexible analog inputs that can be configured to control, alarm or trip.

Analog Outputs:

Refer to Table 2-3. Analog Outputs.

Compressor VFD:

- 4-20mA output to control compressor motor speed with a Variable Frequency Drive (VFD).

Condenser VFD:

- 4-20mA output to control one condenser fan which is interleaved between the remaining condenser steps for smoother control.

% Slide Valve Position:

- 4-20mA signal that transmits the slide valve position for remote monitoring.

Motorized Valve (V+):

- For a cool compression compressor, this 4-20mA signal controls a motorized valve to regulate the liquid refrigerant level in the oil separator. For a liquid injection application on a standard single screw, this 4-20mA signal controls a motorized valve to regulate the liquid refrigerant injected into the compressor for oil cooling purposes.

Digital & Analog I/O Boards Layout

It is important to install the boards in the proper layout. For the correct digital and analog input/output (I/O) board layout, see Figure 3-2. Digital I/O Board Layout.

Dipswitches

- Each board has a dipswitch which sets its communications address so that it can communicate with the CPU board. The dipswitch settings must be correct or the I/O will not function.

Jumpers

- Jumpers are required on the analog boards to configure them for the type of sensors used. The jumper table for the analog board shows the optional jumper configurations for sensors other than the default Vilter standard. If a different sensor is to be used, the jumpers on the analog board need to be changed. In addition, the configuration for this sensor must be changed in the Instrument Calibration screen. The following illustrations show the Vilter default configurations for the Vission 20/20.

Section 3 • Hardware Architecture

Table 3-2. Analog Inputs (2 of 2)

Board	I/O #	Description	Type
9	28	Auxiliary #12	0-5V, 1-5 V, 0-10V, 4-20 mA, RTD, ICTD
9	29	Auxiliary #13	0-5V, 1-5 V, 0-10V, 4-20 mA, RTD, ICTD
9	30	Auxiliary #14	0-5V, 1-5 V, 0-10V, 4-20 mA, RTD, ICTD
9	31	Auxiliary #15	0-5V, 1-5 V, 0-10V, 4-20 mA, RTD, ICTD
9	32	Auxiliary #16	0-5V, 1-5 V, 0-10V, 4-20 mA, RTD, ICTD

Table 3-3. Analog Outputs

Board	I/O #	Description	Type
10	1	Compressor VFD	4-20 mA
10	2	Condenser VFD	4-20 mA
10	3	% Slide Valve Position	4-20 mA
10	4	Motorized Valve (Cool Compression or Liquid Injection), V+	4-20 mA
10	5	Spare / Unused	4-20 mA
10	6	Spare / Unused	4-20 mA
10	7	Spare / Unused	4-20 mA
10	8	Spare / Unused	4-20 mA

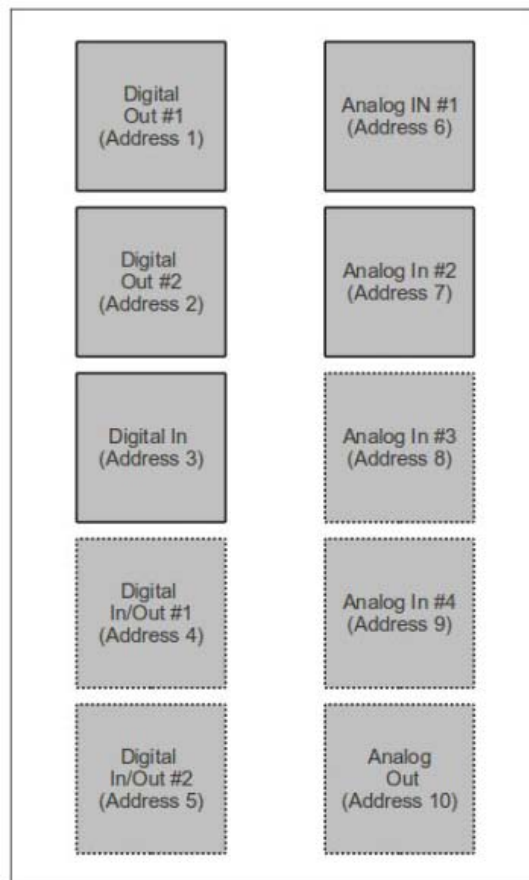

Figure 3-2. Digital I/O Board Layout

Section 3 • Hardware Architecture

Digital Output Boards

The digital output board convert signals generated by the Vision 20/20 program into 120Vac signals that can be energize or signal other devices. All the signals are digital in that the only two states available or either on or off. See board layout, Figure 3-3. Digital Output Board Layout.

Signal LED's:

- Marked in the diagram below in Blue. These LED's indicated when a 120Vac output is being produced.

Voltage LED's:

- Marked in the diagram below in Orange. These LED's indicated the correct voltage of both the 5Vdc and 24Vdc power sources.

Communication LED's:

- Marked in the diagram below in Green. These LED's Show the active communications between the digital output board and the Vision 20/20 CPU board.

Address Dipswitches:

- Marked in the diagram below in Red. These dipswitches are used to assign each board its address position. The addresses are binary and therefor the address of a digital output board will either be address as 1 (0001) or 2 (0010).

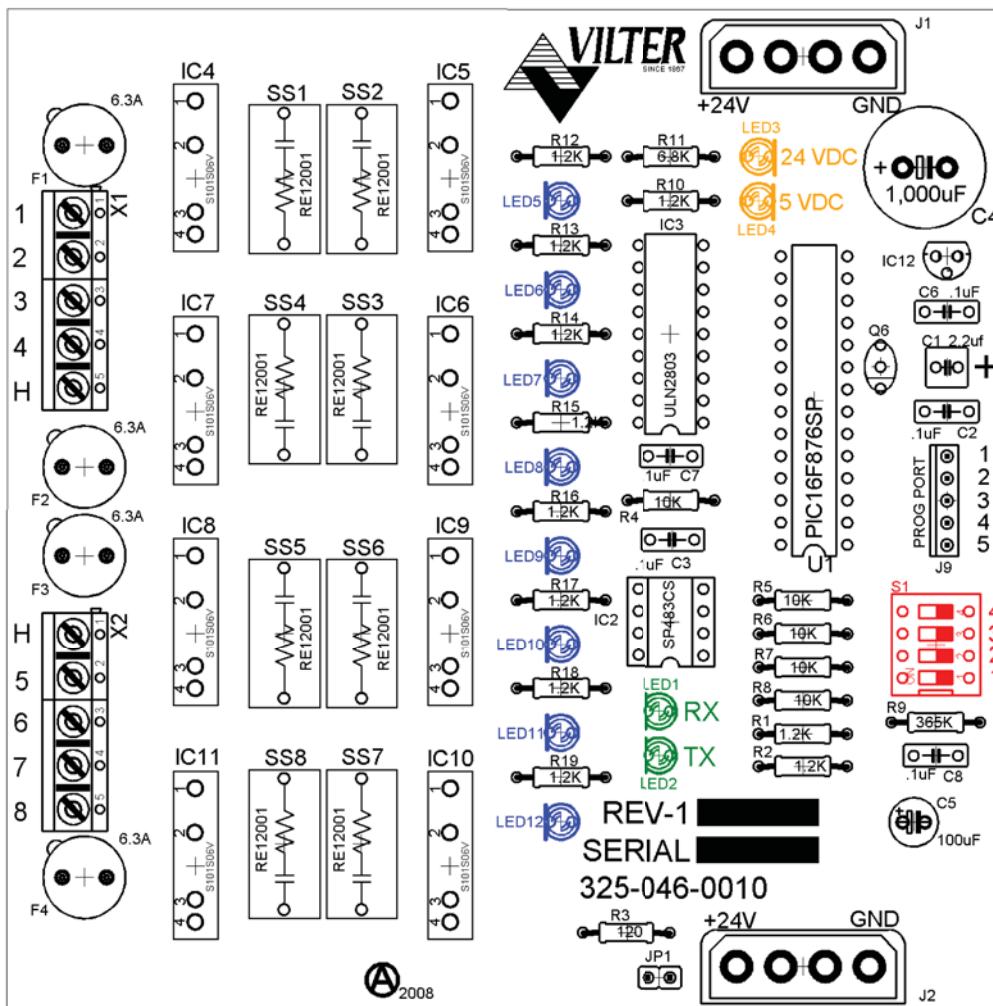

Figure 3-3. Digital Output Board Layout

Section 3 • Hardware Architecture

Digital Input Boards

The digital input board convert 120Vdc signals from external devices to signal for the Vission 20/20 program. All the signals are digital in that the only two states available or either on or off. See board layout, Figure 3-4. Digital Input Board Layout.

Signal LEDs:

- Marked in the diagram below in light Blue. These LEDs indicated when a 120Vac input is detected.

Voltage LEDs:

- Marked in the diagram below in Orange. These LEDs indicated the correct voltage of both the 5Vdc and 24Vdc power sources.

Communication LEDs:

- Marked in the diagram below in Green. These LEDs Show the active communications between the digital output board and the Vission 20/20 CPU board.

Address Dipswitches:

- Marked in the diagram below in Red. These dip-switches are used to assign each board its address position. The addresses are binary and therefor the address of a digital input board can only be addressed as 3 (0011).

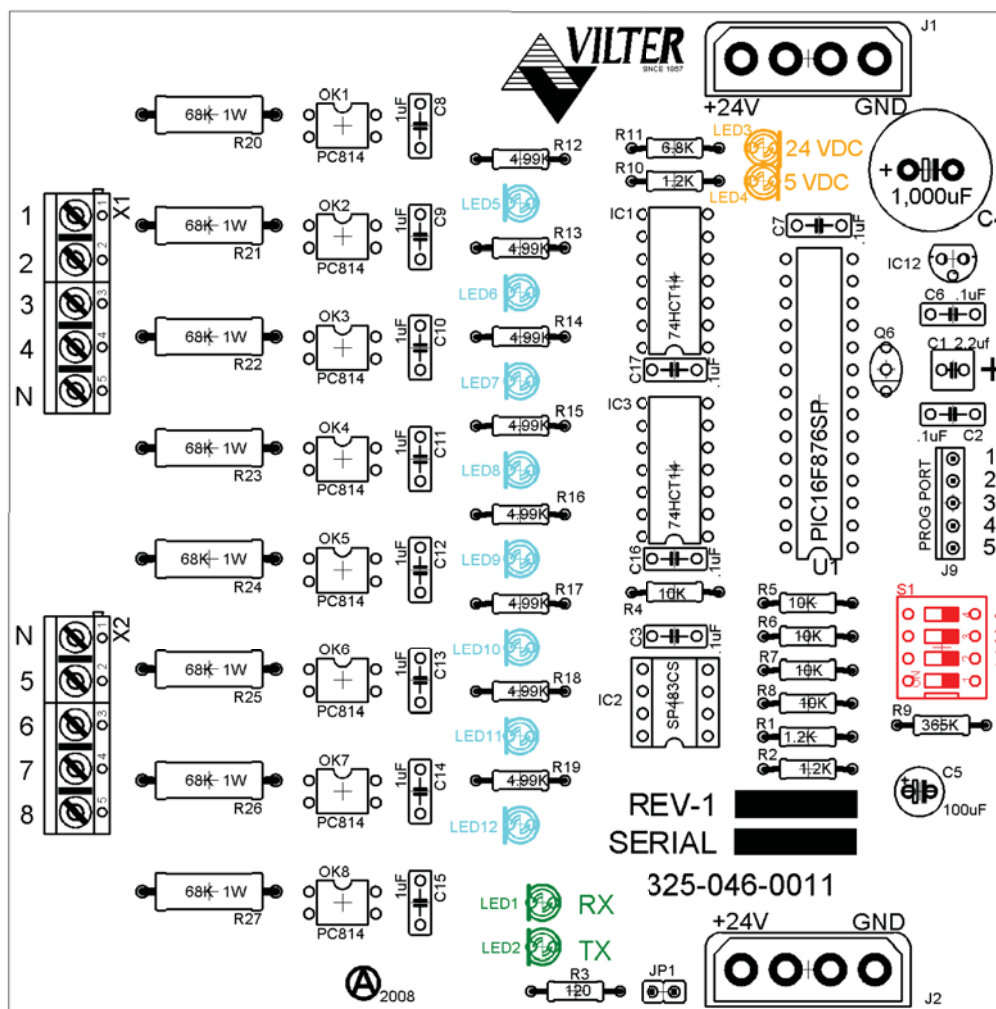

Figure 3-4. Digital Input Board Layout

Section 3 • Hardware Architecture

Digital In-Out Boards

The digital input - output board convert signals generated by the Vision 20/20 program into 120Vac signals as well as detect external 120Vac inputs to signal the Vision 20/20 program.

All the signals are digital in that the only two states available or either on or off. See board layout, Figure 3-5. Digital Input-Output Board Layout.

Signal LEDs:

- Marked in the diagram below in Blue or outputs and light blue for inputs. These LEDs indicate when a 120Vac output is being produced or a 120Vac signal is detected.

Voltage LEDs:

- Marked in the diagram below in Orange. These LEDs indicated the correct voltage of both the 5Vdc and 24Vdc power sources.

Communication LEDs:

- Marked in the diagram below in Green. These LEDs show the active communications between the digital output board and the Vision 20/20 CPU board.

Address Dipswitches:

- Marked in the diagram below in Red. These dipswitches are used to assign each board its address position. The addresses are binary and therefore the address of a digital output board will either be address as 4 (0100) or 5 (0101).

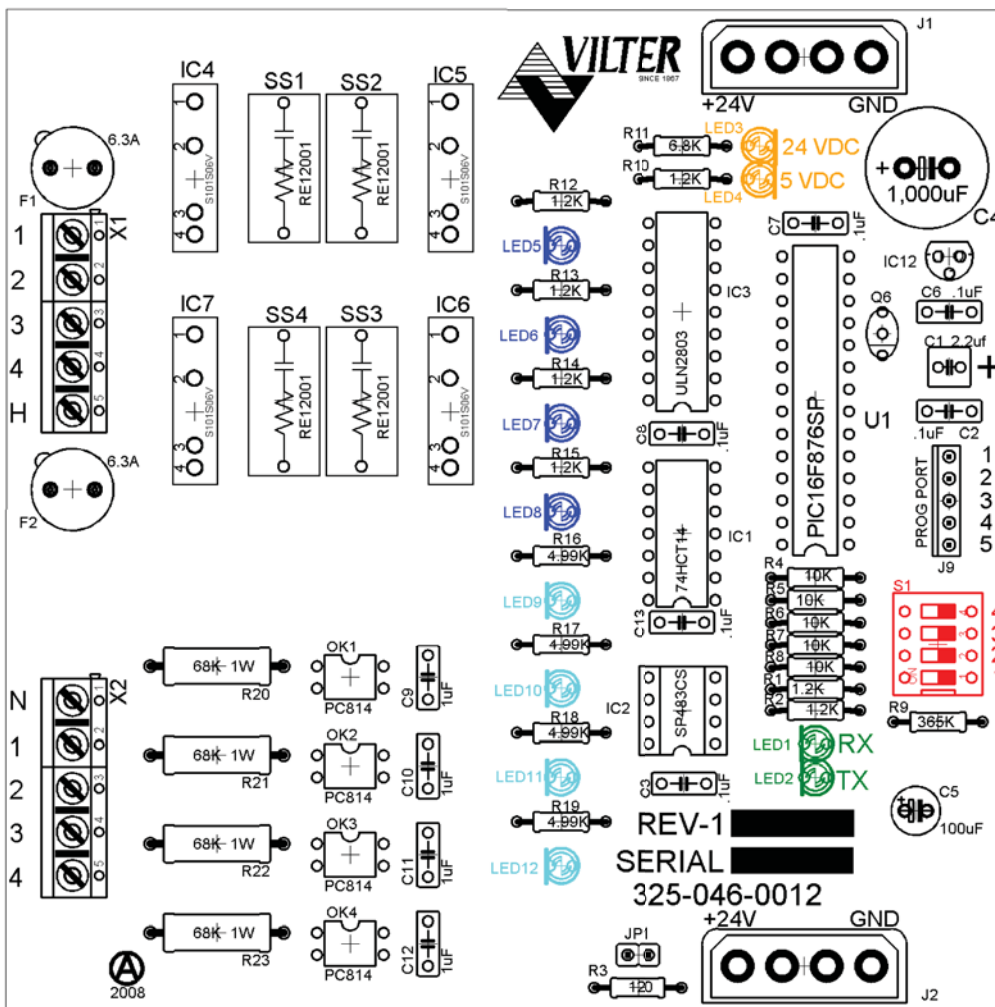

Figure 3-5. Digital Input-Output Board Layout

Section 3 • Hardware Architecture

Analog Input Boards

The analog input board convert varying DC signals into a signal that can interpreted by the Vission 20/20 program. The signals are considered analog because the input DC signal can vary from the minimum value to the maximum value. See board layout, Figure 3-6. Analog Input Board Layout.

Configuration Jumpers:

- Marked in the diagram below in Purple. The jumpers allow the operator to configure the signal type and range for incoming analog signals. For the correct jumper setting for a giving application, see Table 2-4. Analog Input Jumper Tables.

Voltage LEDs:

- Marked in the diagram below in Orange. These LEDs indicated the correct voltage of both the 5Vdc and 24Vdc power sources.

Communication LEDs:

- Marked in the diagram below in Green. These LEDs Show the active communications between the digital output board and the Vission 20/20 CPU board.

Address Dipswitches:

- Marked in the diagram below in Red. These dip-switches are used to assign each board its address position. The addresses are binary and therefore the address of a digital output board will be address as 6 (0110), 7 (0111), 8 (1000) or 9 (1001).

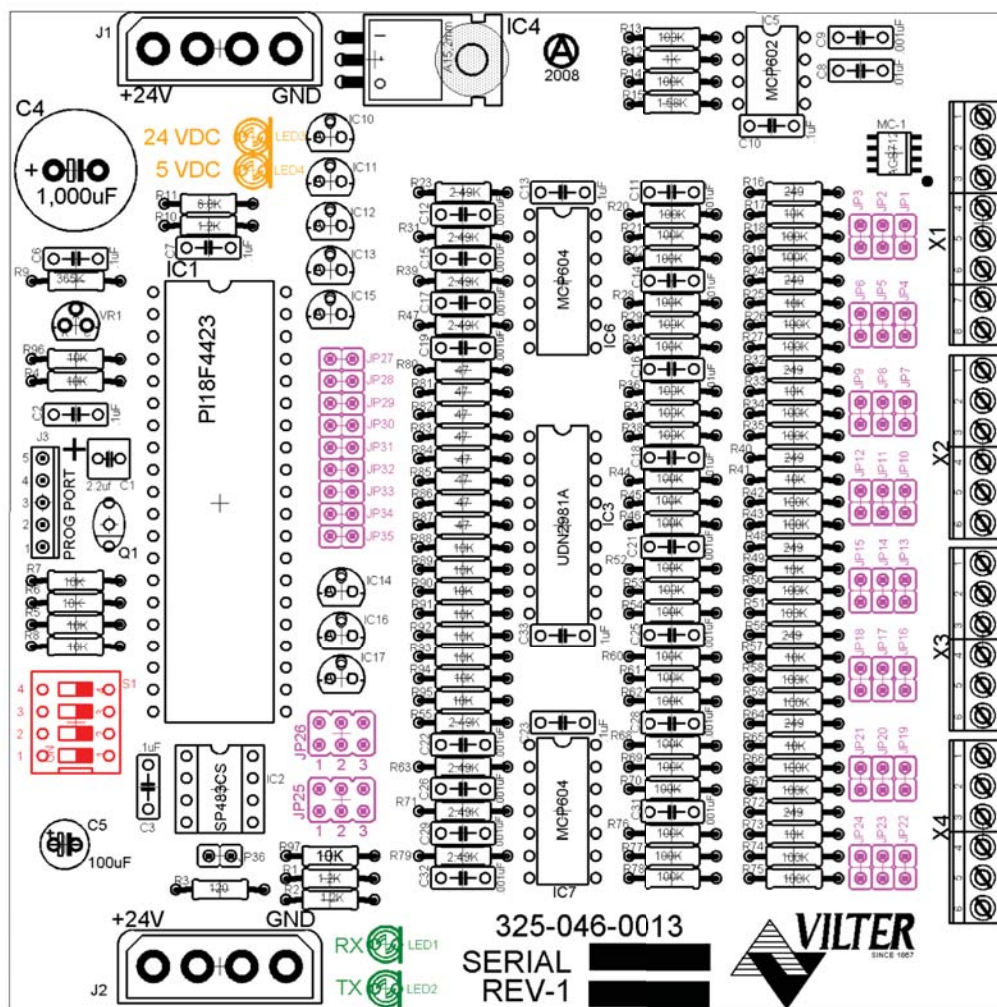

Figure 3-6. Analog Input Board Layout

Section 3 • Hardware Architecture

Analog Input Jumper Tables

The following tables are used to configure each channel of the analog input board signal type and range desired by the operator, see Table 2-4. Analog Input Jumper Tables.

Table 3-4. Analog Input Jumper Tables

CHANNEL 1	SIGNAL	JP-1	JP-2	JP-3	JP-27	JP-35
Analog Input 1-A*	0-5 AMP	OUT	OUT	OUT	OUT	IN
Analog input 1-B**	0-5 VOLT	OUT	OUT	OUT	OUT	OUT
	1-5 VOLT	OUT	OUT	OUT	OUT	OUT
	0-10 VOLT	OUT	OUT	IN	OUT	OUT
	4-20 mA	IN	OUT	OUT	OUT	OUT
	ICTD	OUT	IN	OUT	OUT	OUT
	RTD	OUT	OUT	OUT	IN	OUT

*Use Analog Input 1-A when 0-5 AMP secondary current transformers are installed in the motor starter.

**Use Analog Input 1-B when current transformers are installed in the motor starter.

CHANNEL 2	SIGNAL	JP-4	JP-5	JP-6	JP-28
Analog Input 2	0-5 VOLT	OUT	OUT	OUT	OUT
	1-5 VOLT	OUT	OUT	OUT	OUT
	0-10 VOLT	OUT	OUT	IN	OUT
	4-20 mA	IN	OUT	OUT	OUT
	ICTD	OUT	IN	OUT	OUT
	RTD	OUT	OUT	OUT	IN

CHANNEL 3	SIGNAL	JP-7	JP-8	JP-9	JP-29
Analog Input 3	0-5 VOLT	OUT	OUT	OUT	OUT
	1-5 VOLT	OUT	OUT	OUT	OUT
	0-10 VOLT	OUT	OUT	IN	OUT
	4-20 mA	IN	OUT	OUT	OUT
	ICTD	OUT	IN	OUT	OUT
	RTD	OUT	OUT	OUT	IN

CHANNEL 4	SIGNAL	JP-10	JP-11	JP-12	JP-30
Analog Input 4	0-5 VOLT	OUT	OUT	OUT	OUT
	1-5 VOLT	OUT	OUT	OUT	OUT
	0-10 VOLT	OUT	OUT	IN	OUT
	4-20 mA	IN	OUT	OUT	OUT
	ICTD	OUT	IN	OUT	OUT
	RTD	OUT	OUT	OUT	IN

Table 3-4. Analog Input Jumper Tables (Continued)

CHANNEL 5	SIGNAL	JP-13	JP-14	JP-15	JP-31
Analog Input 5	0-5 VOLT	OUT	OUT	OUT	OUT
	1-5 VOLT	OUT	OUT	OUT	OUT
	0-10 VOLT	OUT	OUT	IN	OUT
	4-20 mA	IN	OUT	OUT	OUT
	ICTD	OUT	IN	OUT	OUT
	RTD	OUT	OUT	OUT	IN

CHANNEL 6	SIGNAL	JP-16	JP-17	JP-18	JP-32
Analog Input 6	0-5 VOLT	OUT	OUT	OUT	OUT
	1-5 VOLT	OUT	OUT	OUT	OUT
	0-10 VOLT	OUT	OUT	IN	OUT
	4-20 mA	IN	OUT	OUT	OUT
	ICTD	OUT	IN	OUT	OUT
	RTD	OUT	OUT	OUT	IN

CHANNEL 7	SIGNAL	JP-19	JP-20	JP-21	JP-33	JP-25
Analog Input 7	0-5 VOLT	OUT	OUT	OUT	OUT	2
	1-5 VOLT	OUT	OUT	OUT	OUT	2
	0-10 VOLT	OUT	OUT	IN	OUT	2
	4-20 mA	IN	OUT	OUT	OUT	2
	ICTD	OUT	IN	OUT	OUT	2
	RTD	OUT	OUT	OUT	IN	2
	ACTUATOR	OUT	OUT	OUT	OUT	1
	POTENTIOMETER	OUT	OUT	OUT	OUT	3

CHANNEL 8	SIGNAL	JP-22	JP-23	JP-24	JP-34	JP-26
Analog Input 8	0-5 VOLT	OUT	OUT	OUT	OUT	2
	1-5 VOLT	OUT	OUT	OUT	OUT	2
	0-10 VOLT	OUT	OUT	IN	OUT	2
	4-20 mA	IN	OUT	OUT	OUT	2
	ICTD	OUT	IN	OUT	OUT	2
	RTD	OUT	OUT	OUT	IN	2
	ACTUATOR	OUT	OUT	OUT	OUT	1
	POTENTIOMETER	OUT	OUT	OUT	OUT	3

Section 3 • Hardware Architecture

Analog Output Boards

The Analog Output board convert signals form the Vision 20/20 program into a current ranging from 4mA to 20mA, see Figure 3-7. Analog Output Board Layout.

Voltage LEDs:

- Marked in the diagram below in Orange. These LEDs indicated the correct voltage of both the 5Vdc and 24Vdc power sources.

Communication LED's:

- Marked in the diagram below in Green. These LEDs show the active communications between the digital output board and the Vision 20/20 CPU board.

Address Dipswitches:

- Marked in the diagram below in Red. These dipswitches are used to assign each board its address position. The addresses are binary and therefore the address of a digital output board will only be addressed as 10 (1010).

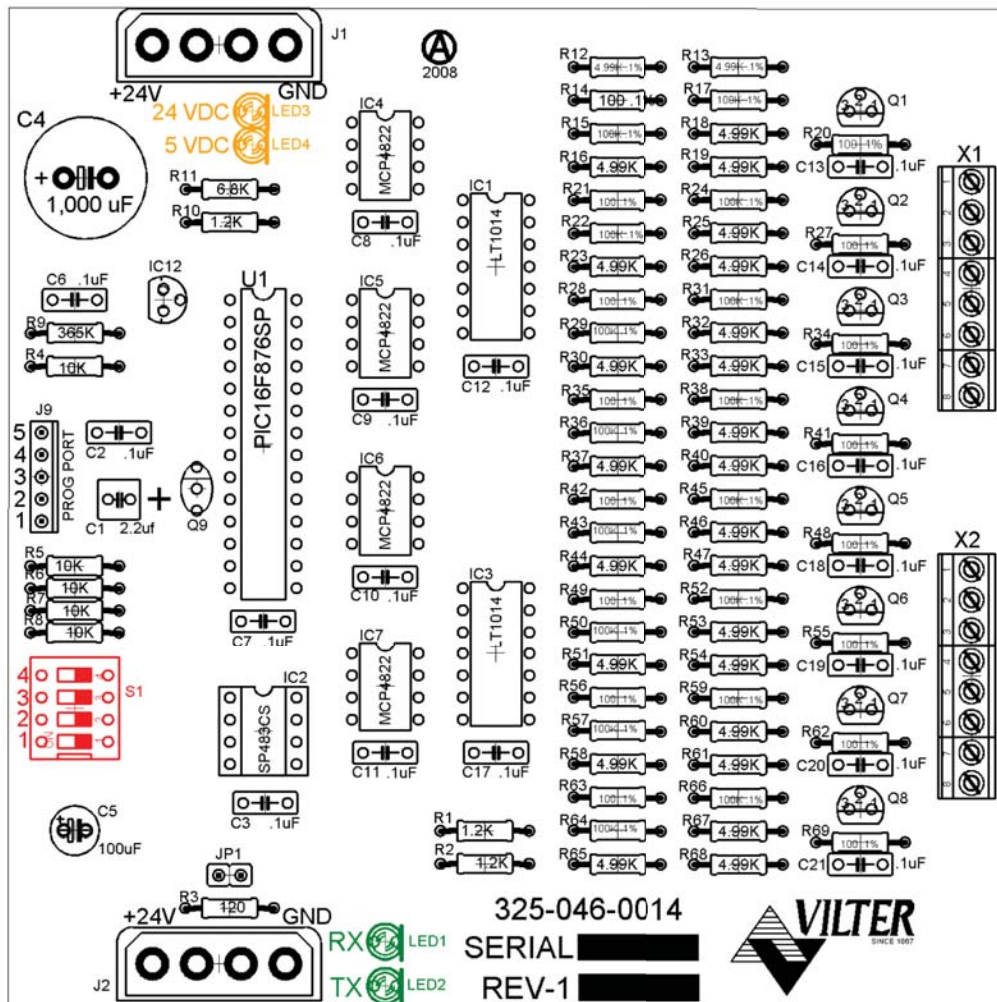

Figure 3-7. Analog Output Board Layout

Section 4 • Main Screen

Overview

The Main Screen is the first screen encountered when powering up the Vission 20/20 Panel, see Figure 4-1. Main Screen. This screen is designed as the starting point for all succeeding screens and provides as much information as possible at a glance. The Main Screen is divided into four sections. Three of the sections are static;

Top Status Bar, Bottom Status Bar and Parameters Bar. These three sections of the main screen will remain visible while navigating through other screens and provide a constant view of critical information. The splash screen is the only dynamic section. All navigation to any other screens will be performed through the Main Screen.

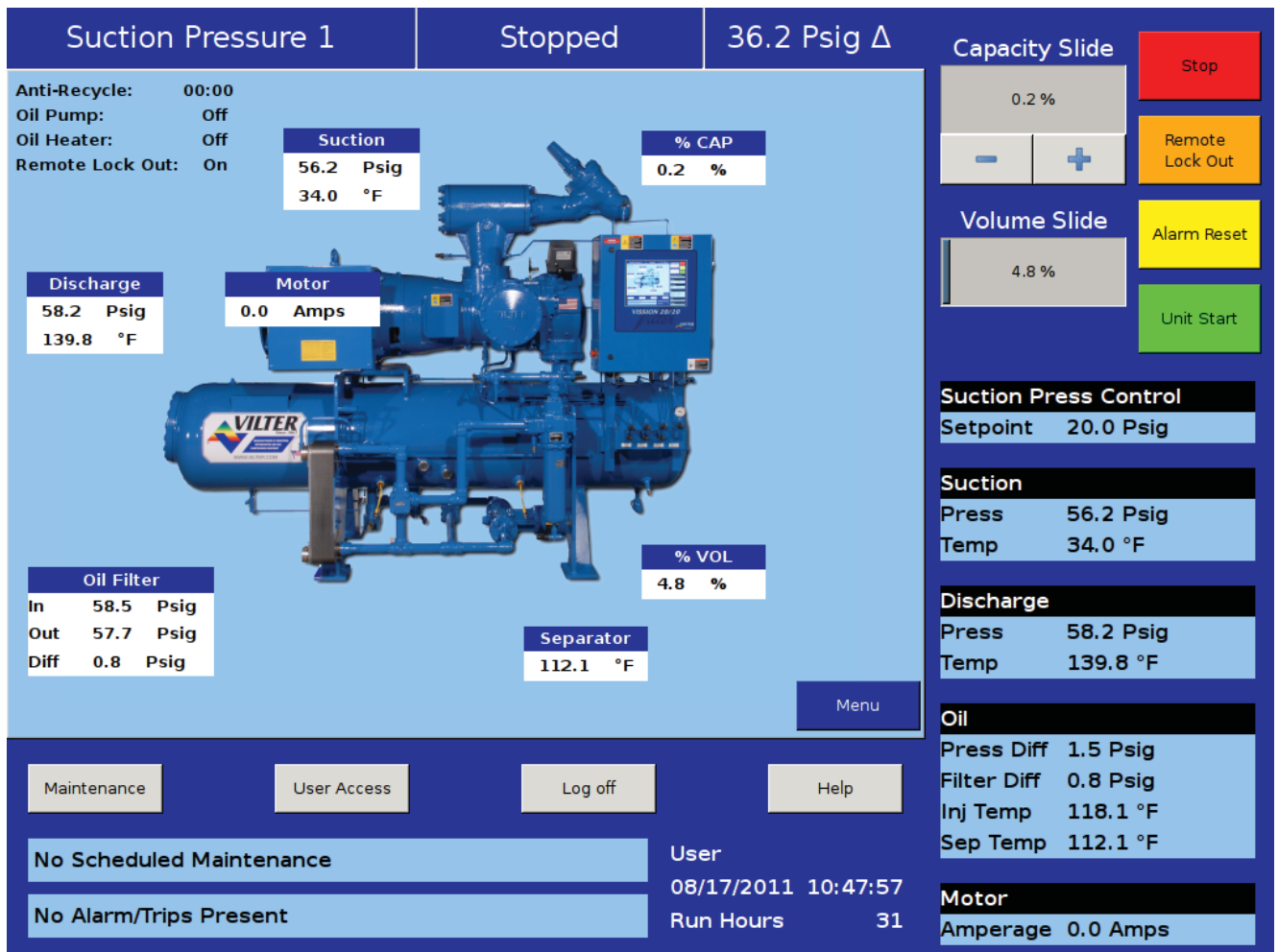

Figure 4-1. Main Screen

Section 4 • Main Screen

Top Status Bar

The standard view of the status bar shows three pieces of information. From left to right, the bar shows the control method, the current run mode, and the difference between the desired control setpoint and the actual value of the processes control value, see Figure 4-2. Top Status Bar.

The status bar also has an alternate function where it displays to the user any information that requires user attention or intervention. It accomplishes this by changing the status bar's color and/or flashing a additional information bars over the standard status bar view.

Standard Bar – blue:

- Indicates a condition where the compressor motor is not running.

Standard Bar – green:

- Informs the operator that the compressor motor is currently running.

Information Bars will flash their information over the top of the status bar. The operator will see the status bar and then one or more information bars in a repetitive sequence.

Information Bar – blue:

- Shows various operational modes that are different than normal running condition. An example of this would be a load limit condition. The compressor is not able to completely load due to some parameter like high motor current and therefore the operator is notified via this type of information bar.

Information bar – yellow

- This typically indicates an Alarm condition. Alarm conditions do not stop the compressor but it is meant to alert the operator of conditions that if corrective action is not taken, then a compressor trip can result.

Information bar – red

- Informs the operator that the compressor motor was stopped due the condition listed in the information bar. Compressor trips are designed to protect the equipment and any personnel operating the equipment.

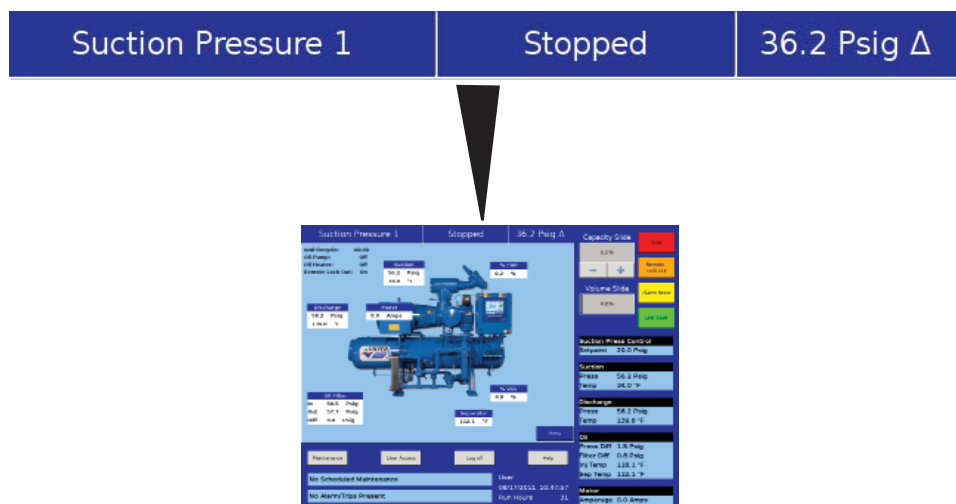

Figure 4-2. Top Status Bar

Section 4 • Main Screen

Parameter Bar

The main purpose of the Parameter Bar is to display the common operational parameters that the operator would be most concerned with. It also gives the operator access to critical buttons such as the stop and start buttons, see Figure 4-3. Parameter Bar.

Capacity Slide Indicator:

- Shows the position of the capacity slide from 0% to 100% via a horizontal blue bar. The buttons below the indicator are used in manual capacity control. The “-” button will decrease the capacity position and the “+” button will increase the position.

Volume Slide Indicator:

- Shows the position of the volume slide from 0% to 100% via a horizontal blue bar. In some cases, increase and decrease buttons will appear below the volume indicator. The buttons only appear if the operator who is logged on has sufficient privileges. If available, the buttons work to increase and decrease the volume slide position in the same manner as the capacity slide.

Stop Button:

- When pressed, stops the compressor in all cases.

Remote Lock Out Button:

- When pressed, activates the remote lock out option. This is a safety feature that prevents any external devices from assuming control and starting the compressor. To release the remote lock out, the operator must press the unit start button and then the remote button when the start dialog box appears.

Alarm Reset Button:

- When pressed, clears any current alarms, trips or status messages that may be displayed on the information bar. Note, if the condition that created the alarm, trip or status message still exists, the message will reappear.

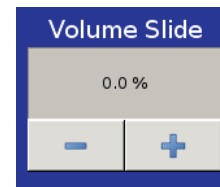
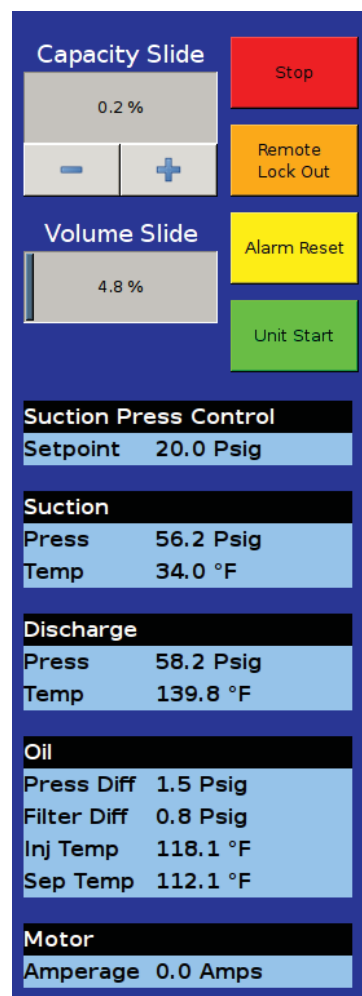
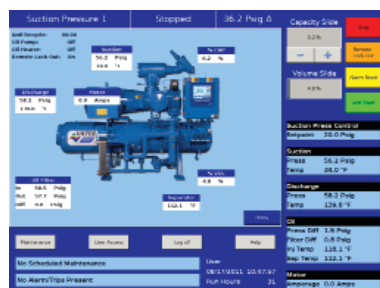

Figure 4-3. Parameter Bar

Section 4 • Main Screen

Parameter Bar (Continued)

Unit Start Button:

- When pressed, a start dialog box will appear that will give the operator a number of run options; Auto, Manual, Remote, or auto sequencing, see Figure 4-4. Unit Start Pop-Up Window.

Control Parameter Boxes:

- The parameter boxes provide updated data on several key control parameters.
 - The top box indicates the desired control setpoint that is set in the Compressor Control Screen. In the case that the Run mode is in remote capacity control, this box will show the desired capacity position.

- The suction box shows the current suction pressure and suction temperature.
- The discharge box shows the current discharge pressure and discharge temperature .
- The oil box shows the pressure differential which is calculated as oil filter out pressure minus suction pressure. Filter differential is calculated as oil filter in pressure minus oil filter out pressure. “Inj Temp” is the temperature of the oil at the oil injection port and “Sep Temp” is the temperature of the oil in the separator.
- The motor box shows the motor current.

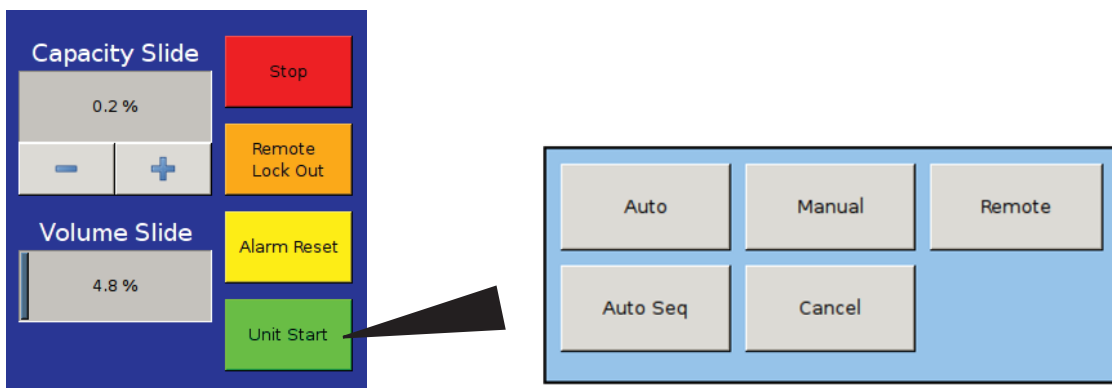

Figure 4-4. Unit Start Pop-Up Window

Section 4 • Main Screen

Bottom Status Bar

The bottom status bar gives the operator easy access to some basic functions and information. The functions are available via the four buttons, see Figure 4-5. Bottom Status Bar.

Maintenance Button:

- Pressing the maintenance button will give the operator access to the maintenance charts and sign off tables.

User Access Button:

- This button takes the operator to another login

screen to create additional users.

Log off Button:

- Pressing the log off button logs off the correct user if any are logged in.

Help Button:

- Pressing the help button takes the operator to the help screen where the operator can access an operation and service manual and also get access to program information.

Status Bars

- The information available is provided by two status bars, one for maintenance activities and the other for any alarms or trips that might be active. To the right of the status bars are positions for displaying the current user (if any are logged in), the date and time, and the total run hours of the compressor.

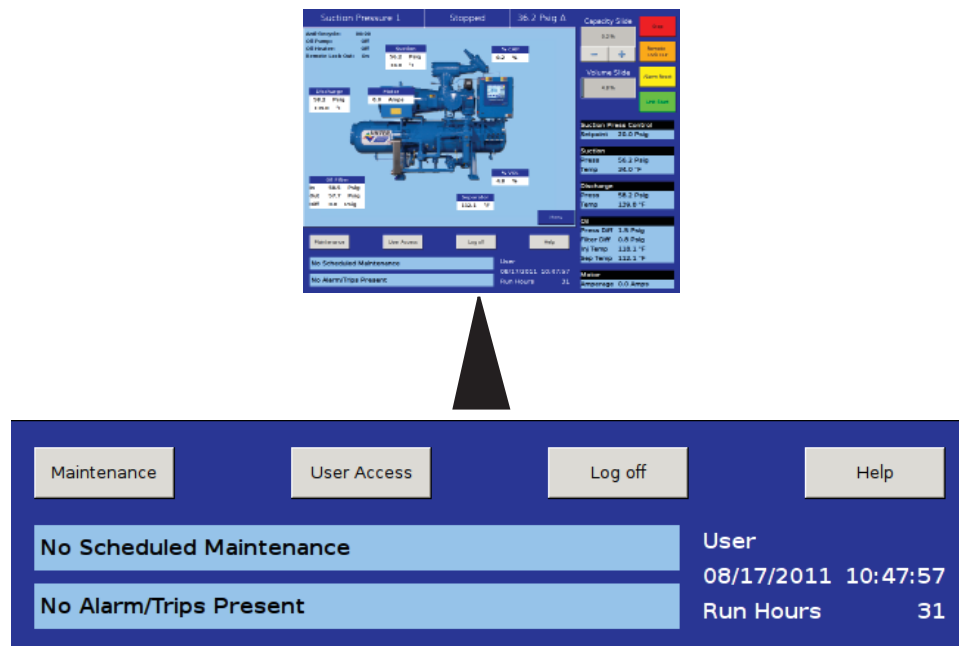

Figure 4-5. Bottom Status Bar

Section 4 • Main Screen

Splash Screen

The splash screen is the dynamic portion of the screen that will change as the operator navigates through the Vision 20/20 panel screen, see Figure 4-6. Splash Screen. The main screen shows a graphic of a Vilter compressor with a number of data boxes spread across the screen. Also on the top left are several indicators.

Discharge:

- Displays the discharge pressure and temperature.

Oil Filter:

- Displays the oil filter inlet pressure, oil filter outlet pressure, and oil differential pressure across the oil filter.

Suction:

- Displays the suction pressure and temperature.

Motor:

- Displays the motor current. When the motor VFD is enabled, this box will also display the motor RPM.

Separator:

- Displays the temperature of the oil in the separator.

% Cap:

- Displays the position of the capacity slide from 0% to 100%.

Process:

- When the Process control is selected as the control mode, this box will appear and displays the process temperature.

% Vol:

- Displays the position of the volume slide from 0% to 100% .

Anti-Recycle:

- Displays the anti-recycle time, if applicable.

Oil Pump:

- The oil pump on a Vilter compressor often cycles on and off depending on differential pressure. This indicator informs the operator when the oil pump is running.

Oil Heater:

- The oil heater often cycles on and off depending on the separator oil temperature. This indicator informs the operator when the oil heater is on.

Remote lock out:

- Displays the current status of the remote lock out. While on, no system controller can remotely assume control of the Vision 20/20 panel and start the compressor.

Menu Button:

- When pressed, navigates the operator to the menu screen.

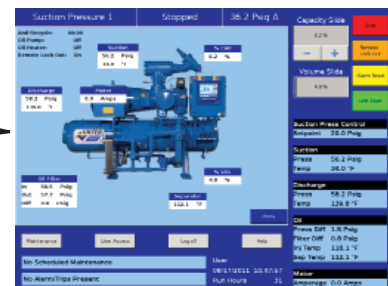
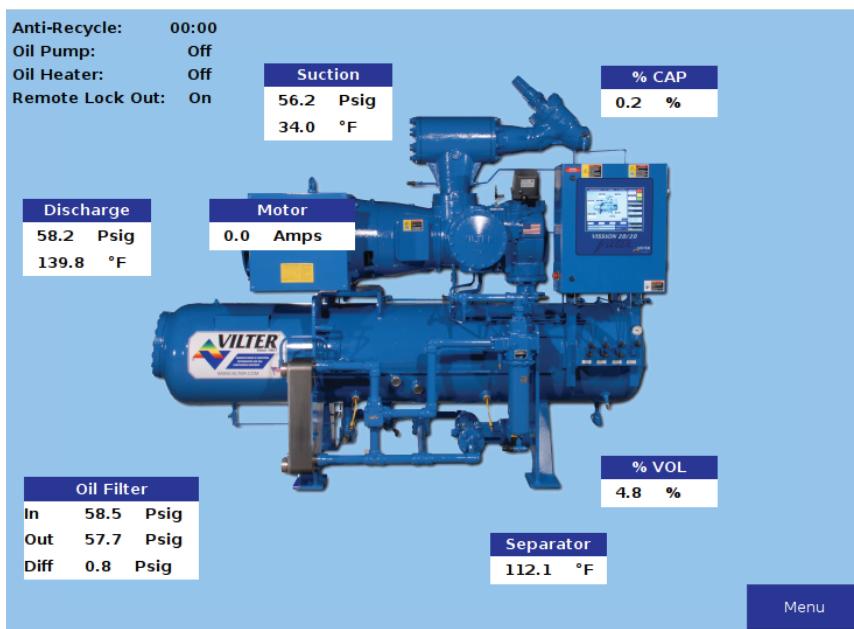

Figure 4-6. Splash Screen

Section 5 • Menu Screen

Overview

The menu screen is the launching point to every other section of the Vision 20/20 panel software. Every screen navigated to from this screen will return to the menu screen upon exiting, see Figure 5-1. Menu Screen.

Navigation Buttons

Compressor control:

- Navigates to the compressor control screen where the operator can set the various compressor control parameters.

Alarms and trips:

- Navigates to the alarms and trips screen where the operator can set the various alarm and trip parameters.

Timers:

- Navigates to the timer screen where the operator can set the various time related parameters.

Compressor scheduling:

- Navigates to the compressor scheduling screen where the operator can set the scheduler to change the control method at settable dates and times.

Compressor sequencing:

- Navigates to the compressor sequencing screen where the operator can set-up compressor to sequence up to four other compressors. This is also sometimes known as lead-lag control.

Condenser control:

- Navigates to the condenser control screen where the operator can set up local condenser control parameter.

Vilter VFD:

- Not currently available.

Service options:

- Navigates to the service options screen where the operator can manually turn on/off digital and analog outputs for maintenance and diagnostics purposes.

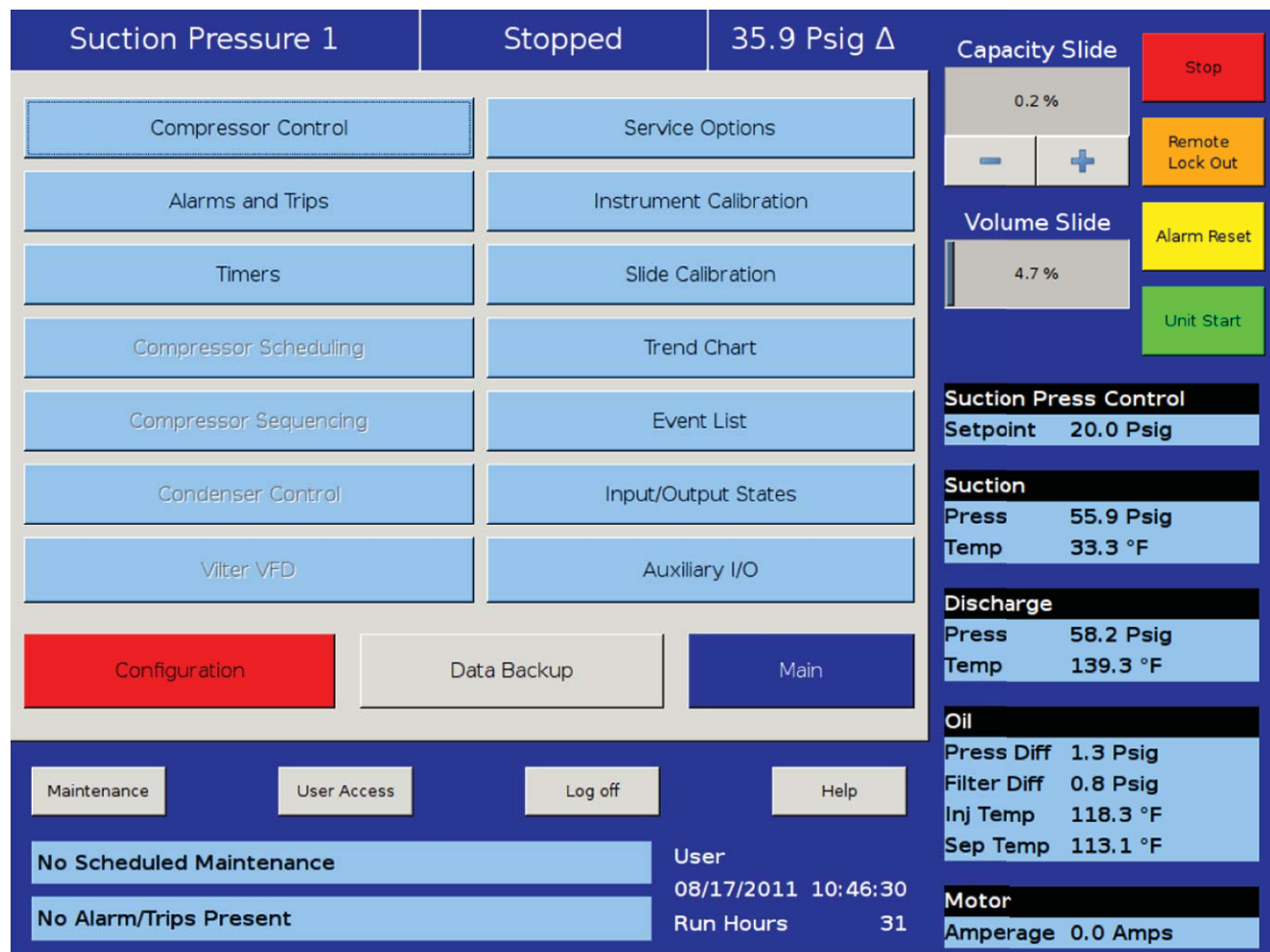

Figure 5-1. Menu Screen

Section 5 • Menu Screen

Instrument calibration:

- Navigates to the instrument calibration screen where the operator can calibrate all of the system sensors.

Slide calibration:

- Navigates to the slide calibration screen where the operator can calibrate the capacity and volume slide actuators.

Trend chart:

- Navigates to the trend chart screen where the operator can select up to four parameters for graphical historical data trending.

Event list:

- Navigates to the event list screen where the operator can view the systems events such as trips or alarms in descending chronological order.

Input/output states:

- Allows viewing of the live data of all analog and digital input and outputs. Also allows viewing of a “snapshot” of all analog and digital input and outputs at the time of the last compressor fault event.

Auxiliary I/O

- Navigates to the auxiliary I/O screen where an operator can configure any auxiliary instruments or devices.

Configuration:

- Navigates to configuration screens where the initial system parameters are configured.

Data backup:

- Allows the operator to backup setpoints, configuration parameters, and calibration settings to a USB memory device. In addition, this allows the restoration of previously saved database files.

Main:

- Navigates back to the main screen.

Section 6 • Compressor Control

Overview

The compressor control screen is where an operator can set the majority of the compressor settings. These settings define how the compressor will operate and respond to changing loads. The compressor control screen consists of several screens but in order not to overwhelm the operator with options, many of the screens may not be visible. How the compressor is configured in the configuration screen will determine what screens are displayed. It is important to note that there isn't one correct way to set these parameters. Every application is different and requires the operator to tune these settings to achieve the best operation, see Figure 6-1. Compressor Control Screen.

Pulse Proportional Control

The Vision 20/20 uses a pulse proportional control method to control the compressor capacity slide valve

in order to maintain the control setpoint. The control setpoint can either be process temperature control setpoint or suction pressure control setpoint depending on what the operator has selected as the control mode.

The proportion control uses the Interval Time Setpoint to define the time the algorithm waits to read the current setpoint and calculates the error from the process control setpoint. Based on the error from setpoint, the algorithm calculates a pulse time in which the capacity slide is moved in the direction of the error. The further away the process variable is from the control setpoint, the larger the corrective pulse will be. The duration of the pulse is limited by the Pulse Time Setpoint. By default the maximum pulse time is the same as the interval time. This means that the pulse time can be 100% of the interval time given a near continuous movement of the capacity slide. Adjusting these setpoints can be useful in slowing down the reaction time of the compressor if large thermal time contents are present in the refrigeration cycle.

The screenshot displays the Compressor Control Screen with the following sections:

- Top Status Bar:** Suction Pressure 1, Stopped, 36.2 Psig Δ
- Suction Pressure Control Panel:**
 - Pressure Control Setpoint: 20.0 Psig (Setpoint 1), 30.0 Psig (Setpoint 2)
 - Capacity Increase: Interval / Pulse Time (4.0 sec, 4.0 sec) for both setpoints
 - Proportional / Dead Band: 4.0 Psig, 10.0 % for both setpoints
 - Capacity Decrease: Interval / Pulse Time (4.0 sec, 4.0 sec) for both setpoints
 - Proportional / Dead Band: 4.0 Psig, 10.0 % for both setpoints
- Auto-cycle Section:**
 - Enable
 - Start Pressure: 28.0 Psig (Setpoint 1), 38.0 Psig (Setpoint 2)
 - Start Delay: 5 sec (both)
 - Stop Pressure: 16.0 Psig (Setpoint 1), 26.0 Psig (Setpoint 2)
 - Stop Delay: 5 sec (both)
 - Min Slide Position: 10 % (both)
- Control Sliders and Buttons:**
 - Capacity Slide: 0.2 % (with Stop, Remote Lock Out buttons)
 - Volume Slide: 4.8 % (with Alarm Reset button)
 - Unit Start button
- Summary Panels:**
 - Suction Press Control: Setpoint 20.0 Psig
 - Suction: Press 56.2 Psig, Temp 32.4 °F
 - Discharge: Press 58.0 Psig, Temp 138.2 °F
 - Oil: Press Diff 1.4 Psig, Filter Diff 0.8 Psig, Inj Temp 118.8 °F, Sep Temp 113.1 °F
 - Motor: Amperage 0.0 Amps
- Navigation and Maintenance:**
 - Page 1 (selected), 2, 3, 4, 5, 6, Menu
 - Maintenance, User Access, Log off, Help buttons
 - No Scheduled Maintenance, No Alarm/Trips Present
 - User: 08/17/2011 11:08:00, Run Hours: 31

Figure 6-1. Compressor Control Screen

Section 6 • Compressor Control

As mentioned in the above paragraph, the distance of the process variable from the control setpoint determines the size of the pulse used to move the capacity slide. This is called the proportional band and is set by the Proportional Setpoint. When the process variable is outside the proportional band, the slide will move in the direction of the error continuously. Increasing the size of the proportional band can help slow the compressors reaction by varying loads if desired, see Figure 6-2. Proportional Band & Setpoint.

The Dead Band Setpoint defines area around the control setpoint where the algorithm stops adjusting the capacity slide. This area is a percentage of the proportional band. By default the proportional band is set to 4 Psig and the dead band is set to 10% of 4 Psig. Making the dead band ± 0.4 Psig of the control setpoint. Once the process variable is within the dead band, the algorithm considers the compressor to be on setpoint. If the operator wishes the compressor to operate closer, the setpoint can be set to a smaller percentage. However this

will result in the capacity slide excessively moving to maintain the setpoint and could over heat the actuator or shorten the actuators operational life.

Auto-Cycle

The auto-cycle setpoints define the control points in which the compressor will automatically cycle on and off when the compressor has been placed into “Auto” run mode. These setpoints can be “enabled” or “disabled” using the check box. A delay can be entered to momentarily delay the start or stop from immediately occurring when the setpoint is met. If a compressor shutdown is desired on a suction pressure drop and a manual reset is required, set the OFF value below the Low Suction Pressure safety trip value. This will shut down the compressor and a Reset will be required to restart it.

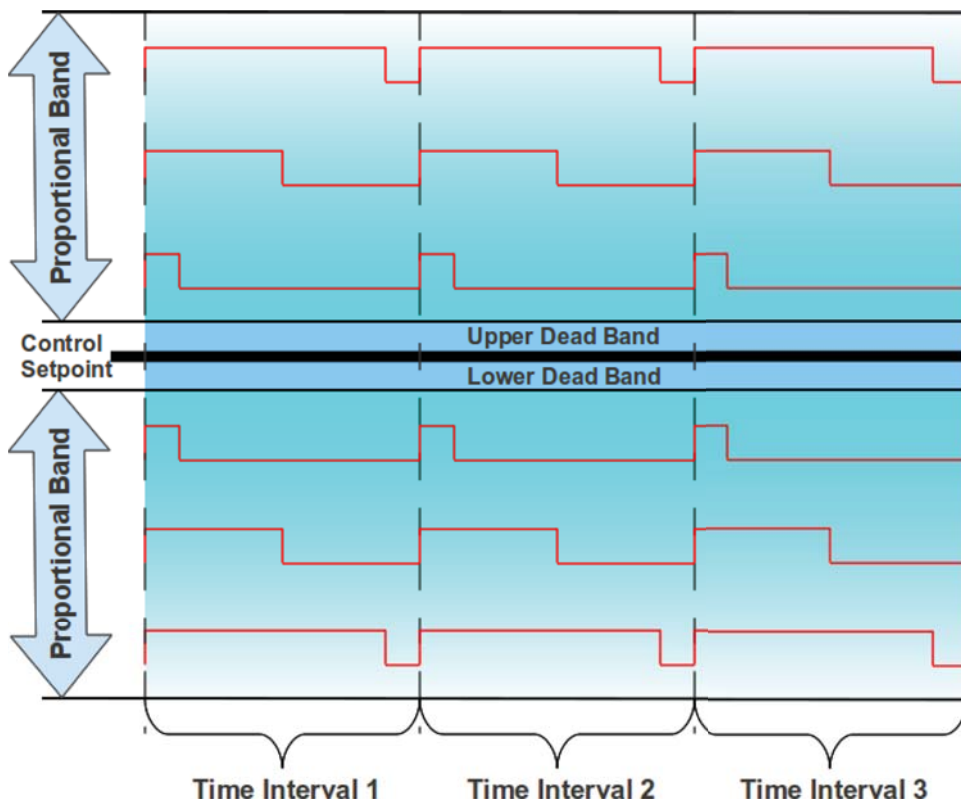

Figure 6-2. Proportional Band & Setpoint

Section 6 • Compressor Control

The auto-cycle function will operate only in local “Auto” mode and Direct I/O “Remote Auto” mode. If the auto-cycle feature is enabled while running in any other remote mode, the function will simply be ignored. However, the Minimum slide position will continue to be respected in Remote “Auto” mode. If the compressor changes from a remote mode back to Local “Auto” mode, the auto-cycle feature will operate normally.

NOTE

When the Pump-down Feature is enabled, the Auto-cycle setpoints are automatically disabled. Pump-down mode will cause the compressor to cycle off via the Pump-down Stop Pressure setpoint, and will not allow the compressor to start again.

Enable:

- Enables the Auto-cycle control. Uncheck the box to disable the Auto-cycle set-points.

Start Pressure:

- When the suction pressure meets or exceeds this setpoint, the compressor will start.

Start Delay:

- Delays the compressor from starting when the suction pressure meets or exceeds this setpoint.

Stop Pressure:

- When the suction pressure meets or falls below this setpoint, the compressor will stop.

Stop Delay:

- Delays the compressor from stopping when the suction pressure meets or exceeds this setpoint.

Minimum Slide Position:

- The minimum capacity slide position that the compressor is allowed to run at.

Variable Frequency Drive (VFD)

The VFD page is where the operator can tune the motor VFD for desired operation. A Vilter compressor uses the variable speed of a VFD controlled motor to vary the amount of work or capacity of the compressor. The basic one step VFD control will use the capacity slide to control the first half of the total available capacity and the motor speed to control the second half of the total available capacity, see Figure 6-3. VFD One-Step Control Method. For example, if the compressor needs to load to 100% of its capacity. The control algorithm will first move the capacity slide to its maximum position, then the motor speed will ramp up to its maximum speed. In the unloading direction, the motor speed will ramp down to its minimum speed, then the capacity slide will move to its minimum position.

The two-step control method works much like the one-step method but divides the control into four sections, see Figure 6-4. VFD Two-Step Control Method. While loading; the compressor will first move the capacity slide to the maximum set for step one then speed up the motor to its maximum speed for the same step. Once step one has completed, the control algorithm will again move the capacity slide to the maximum position and the maximum speed of step two. At this point the compressor would be fully loaded. Unloading occurs in the reverse direction. The two-step control method is not typical for most installations and is normally used when a Vilter engineer recommends it.

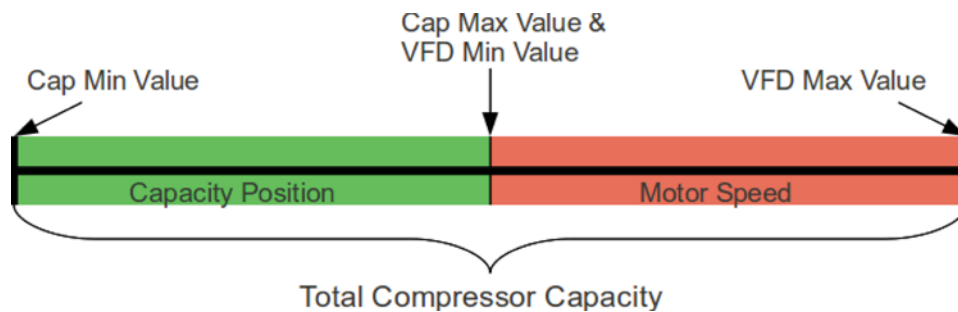

Figure 6-3. VFD One-Step Control Method



Figure 6-4. VFD Two-Step Control Method

Section 6 • Compressor Control

NOTE

VFD installation is not covered in this manual. A VFD that is not properly installed and configured has the potential of causing intermittent and dangerous problems. Please consult your VFD manual.

1 Step VFD Control:

- Enables the first step in the VFD control algorithm. This check box is not deselectable by the operator.

Capacity Slide Position:

- Defines the minimum and maximum positions for the capacity slide. While in 1 step control these values should be 0% for minimum and 100% for maximum.

VFD Speed:

- Defines the minimum and maximum speed for the motor speed. While in 1 step control these values should reflect the full range of the VFD.

2 Step VFD Control:

- Enables the second step in the VFD control algorithm.

Capacity Slide Position:

- Defines the minimum and maximum position of the capacity slide in the 2 step VFD control.

VFD Speed:

- Defines the minimum and maximum speed for the motor in the 2 step VFD control.

P = Proportional (gain) setpoint:

- Used to adjust the motor speed action in direct proportion to the difference between the control setpoint and the process variable (SP - PV error). This is a unit-less quantity and is used for coarse adjustment. This setpoint should be set to the lowest value that gives adequate control system response. Increasing the proportional setting increases the control system's sensitivity to small process fluctuations and the tendency to hunt.

I = Integral (reset) setpoint:

- Used to adjust the capacity control action, integrating the error over time, to account for a small error that has persisted for a long time. This quantity is used for fine adjustment. This setpoint is used to smooth out process variations. This setpoint should be set high enough to prevent hunting but low enough to prevent control system overshoot.

D = Derivative (rate) setpoint:

- Used to adjust the capacity control action, accounting

for how fast the error is changing, positively or negatively. A standard PID loop variable, it is not used for our applications.

Pumpdown Control

The Pumpdown Control defines a method of “pumping” down a chiller, which is to draw off refrigerant from the chiller. This feature can be enabled or disabled from this menu which is the part of Compressor Control Screen. If Pumpdown is enabled, this feature will only function when the compressor is running in local Auto Mode and Control Mode Configured is Suction Pressure.

If Pumpdown Feature is enabled, then;

- The Auto-cycle functionality is ignored. Pumpdown mode will cause the compressor to cycle off via the Pumpdown Stop Pressure setpoint. Normally, the Pumpdown Stop Pressure setpoint will be set lower than the Auto-cycle Stop setpoint. Therefore, as the suction pressure is pulled down, the compressor is prevented from shutting down prematurely via the Auto-cycle Stop setpoint by automatically ignoring the Auto-cycle feature.
- The compressor will be placed into “Stop” mode after the suction pressure is equal to, or goes below the Pumpdown Stop Pressure.

Pumpdown:

- This checkbox enables the Pumpdown feature. If this box is unchecked, Pumpdown setpoints are ignored and the user is not allowed to edit Pumpdown setpoints.

Stop Pressure:

- This setpoint defines the suction pressure value at which the compressor will cycle off. Normally, this setpoint is set below the Suction Pressure Auto-cycle Stop Pressure setpoint.

Stop Delay:

- This setpoint delays the compressor from stopping when the suction pressure is equal to or less than the Stop Pressure.

Min Slide Position:

- The minimum capacity slide is the setpoint that the compressor is allowed to run at. By forcing the compressor capacity to operate at a value above minimum, we insure that the suction pressure will be pulled down to the Stop Pressure setpoint.

Pumpdown Operation (Run/Stop):

- This button starts/stops the Pumpdown operation.

Section 6 • Compressor Control

This button is active only when compressor is in local Auto mode and Control Mode Configured is Suction Pressure. This button will display “Run” when Pumpdown operation has not started or stopped, while button will display “Stop” when Pumpdown operation is running.

When Pumpdown feature is enabled, Pulldown checkbox is automatically grayed out. Similarly when Pulldown feature is enabled, Pumpdown checkbox is automatically grayed out and hence, the user will not be able to operate Pumpdown feature. This is done to keep Pumpdown and Pulldown features mutually exclusive.

Pulldown Control

The Pulldown Control defines a method of slowly pulling the suction pressure down from a high value. This is sometimes required on systems that have liquid recirculation systems or on new building to prevent structural damage by limiting the rate at which to build is cooled.

This feature can be enabled or disabled from this menu which is the part of Compressor Control Screen. If Pulldown is enabled, this feature will only function when the compressor is running in local Auto, Auto Sequencing mode and the Control mode is Suction Pressure 1.

The Pulldown feature provides a method to slowly pull the suction pressure down to operating conditions. The pulldown method used is to step the suction pressure down over a defined time interval.

Example:

Assume the suction pressure is at 85 psig and the setpoint we want to get to is 20 psig. The operator wants to allow 48 hours of pulldown time. Pick a reasonable step pressure of 5 psig for every step. This defines a change of $(80 - 20 = 60)$ psig.

- Note: First step is applied immediately. So first step starts at $(85 - 5 = 80)$ psig
- Number of steps = delta 60 psig change * 1 step/5 psig = 12 steps.
- Delay per Step = 48 hours / 12 steps = 4 hours/step.
- So for the first 4 hours, the compressor runs at 80 psig.
- Next 4 hours @ 75 psig
- Next 4 hours @ 70 psig
- And so forth.

After the 12th step (running at 25 psig), 48 hours will have elapsed, and the new setpoint becomes 20 psig, achieving the 20 psig setpoint after 48 hours. After the pulldown setpoint is equal to or is less than the control setpoint, the pulldown feature will disable itself.

Pulldown:

- This checkbox enables the Pulldown feature. If this box is unchecked, Pulldown setpoints are ignored and the operator is not allowed to edit Pulldown setpoints.

Initiate Pulldown at Next Start:

- This checkbox when enabled, turns on the Pulldown process at the next start cycle, Pulldown operation will work in the following manners:
 - Pulldown only works when Control mode is Suction Pressure 1.
 - If not started in Suction Pressure 1 then Pulldown process will not run until stopped and restarted in Suction Pressure 1.
 - If started in Suction Pressure 1 and changed after start, then Pulldown process will be suspended and restart once Control mode is changed back to Suction Pressure 1.

Step Pressure:

- This setpoint defines the step decrements at which the suction pressure value will be controlled at.

Delay Per Step:

- This setpoint defines the time increment at which the compressor will be controlled at each step.

Stop Pressure:

- This setpoint defines the suction pressure value at which Pulldown operation will get completed. When suction pressure value is equal to or goes below this setpoint, Pulldown feature disables itself. Also “Pulldown” and “Initiate Pulldown at Next Start” checkboxes will be automatically deselected as normally this is one time use feature.

Auto Cycle Differential:

- This setpoint defines the offset pressure values for Auto Cycle Start Pressure and Stop Pressure from the Suction Pressure setpoint. Auto Cycle Start Pressure setpoint will be Suction Pressure setpoint incremented by this setpoint pressure value, while Auto Cycle Stop Pressure value will be Suction Pressure setpoint decremented by this setpoint pressure value.

When Pulldown feature is enabled, Pumpdown checkbox is automatically grayed out. Similarly when Pumpdown feature is enabled, Pulldown checkbox is automatically

Section 6 • Compressor Control

grayed out and hence, the user will not be able to operate Pulldown feature. This is done to keep Pulldown & Pumpdown features mutually exclusive.

Control Mode

This drop down box gives the operator the ability to change the type of control mode such as suction pressure control or process temperature control. The operator can also switch from setpoint 1 and setpoint 2 for each control method. What is available in this dropdown box is dependent on the number and type of control selected in the configuration screen.

Stop Load and Force Unload

The stop load and force unload feature's primary purpose is to attempt to prevent the compressor from tripping off due to particular instrument reading. For example, if the suction pressure drops too low, the compressor will trip off for safety reasons. However, the stop load & force unload algorithm recognizes a potential trip and either stops the compressor from loading up or even unloads the compressor to prevent the trip.

Stop load:

- When this value is reached, the capacity slide will not advance in any condition.

Force Unload:

- When this value is reached, the capacity slide position will decrease until the variable reading is below this value.

High Motor Amps:

- Motor current values for stop load and force unload.

High Discharge Pressure:

- Discharge pressure value for stop load and force unload.

Low Suction Pressure:

- Suction pressure values for stop load and force unload

Capacity Slide Triggered Outputs

The Vission 20/20 offers two digital outputs that can be triggered at a specified capacity slide position. By default, the outputs are preselected for economizer and hot gas bypass. However, these preselected outputs are customizable by the operator.

Slide Valve Setpoint:

- Operator editable labels for the each output.

Slide %:

- Indicates the capacity slide position where the digital output is triggered.

State Below Setpoint:

- Defines the state of the digital output when the slide position is below the "Slide %" setpoint. The operator can choose between "N.O." or "N.C."

Active:

- Check box to enable the digital output.

Volume Slide Position Offset

These setpoints offer the ability to alter the Volume position table to take advantage of potential energy savings. Since the volume position is a function of the capacity position, the offset to the volume is based on the position of the capacity slide. The volume offset can be applied to the entire capacity slide range or just a portion using the Capacity Range minimum and maximum setpoints.

Volume Slide Adjustment %:

- The value in percentage of the volume slide offset.

Capacity Range:

- Defines the range that the volume position slide offset will be applied.

Soft Load

This setpoint is used to slow the loading of the compressor. In some refrigeration systems, a loading compressor can have dramatic effects on the system parameters. This setpoint allows an operator to reduce the continuous load pulse as defined in the proportional control section to a percent duty cycle.

Soft load %:

- Defines the duty cycle of the continuous load pulse. At 100%, the continuous pulse will truly be continuous. At 50%, the continuous pulse would be reduced to half time on and half time off in the time interval defined in the proportional control section.

Section 6 • Compressor Control

Load Anticipating

The purpose of the load anticipating algorithm is to reduce the amount of overshoot of the capacity slide position while the compressor attempts to meet the control setpoint. This advanced feature of the Vission 20/20 closely monitors the rate of change of the process variable and compares it to the control setpoint. If the process variable is changing in the direction of the control setpoint at the specified rate or greater, then the normal command to move the capacity slide is interrupted. The rate is calculated between time intervals set in the proportional control section of this screen.

Enable Load Anticipation Algorithm:

- Allows the operator to choose if the load anticipation algorithm runs.

Rate Dead Band:

- Defines the rate at which the capacity slide movement will be interrupted. This value is an absolute value of the process variable. For example, the default value is 0.25. If the control mode is suction pressure, then this value is 0.25 Psig or if process temperature is the control mode then the value would be 0.25°F.

Oil Control

These setpoints determine how the Vission 20/20 will manage the oil of the compressor.

Oil Pump Press Restart Ratio:

- The on and off setpoints define when the oil pump will cycle on and off if the oil pump is selected to cycle from the configuration screen.

Oil Separator Heater Temp:

- When the oil temperature falls below this setpoint the oil heater will turn on. Note, there is a 5°F differential associated with this setpoint. For example, when set at 100°F, the heater will turn on at 95°F and off at 105°F.

Liquid Injection

The setpoints in this section are to control the behavior of the liquid refrigerant injected into the compressor for oil cooling purposes. The liquid injection solenoid control is based off of discharge temperature whether the compressor uses just an injection solenoid or a motorized valve in conjunction with the solenoid.

Liquid Injection Solenoid Control ONLY

- When using only the liquid injection solenoid, the solenoid is activated once the value of discharge temperature meets or exceeds the value of “Liquid Inj. Setpoint 1” and the value of oil separator temperature meets or exceeds the value of “Oil Sep. Temp. Override”. The injection solenoid will deactivate if either of setpoints are not met. This will prevent situations where the discharge temperature may rise quickly, but the oil temperature is still very cold. By preventing the liquid injection solenoid from turning on at this point, the oil separator will not be subjected to additional liquid refrigerant, that would cool the oil even further.

Liquid Injection Control using a 4-20ma motorized valve.

- When a motorized valve is used to control the amount of liquid being injected into the compressor the previously mentioned setpoints have a slightly different function. The Oil Sep. Temp. Override is still used in controlling the injection solenoid, however the Liquid Inj. Setpoint 1 is now used as the target temperature for the PID Algorithm that controls the position of the motorized valve. The algorithm compares the actual discharge temperature against the Liquid Inj. Setpoint 1. The difference between these is the error. The PID algorithm tries to drive the error to “zero” by moving the positioning valve to allow more or less liquid refrigerant to be injected into the compressor.
- PID algorithm can be notoriously hard to tune. As a result the Vission 20/20 offers a couple of additional features to help control wild fluctuations in oil temperatures that could result in the compressor tripping off. The operator can choose to enable the minimum value position that automatically sets the liquid injection motorized value to the specified value whenever the discharge temperature has fallen below the Liquid inj. Setpoint 1. This feature nearly eliminates the overshoot of the PID in the downward direction and reduces the chance of the compressor tripping off due to low oil temperature. The operator can also choose to use an average of the discharge temperature and the oil manifold temperature as the control variable. The discharge temperature can vary quite drastically forcing the PID algorithm to drastically adjust the motorized value. By averaging the more stable oil manifold temperature and discharge temperature, the control variable stabilizes and the PID is more easily tuned.
- Please note that as stated above, PID algorithms can be difficult to tune and there is no one set of PID values that will work. The work required for a compressor to meet the requirement of its installation vary greatly and therefore the amount of heat transferred to the oil varies just as greatly. We recommend the

Section 6 • Compressor Control

operator consult PID tuning guides available from many different source before attempting to tune this PID.

Liquid inj. Setpoint 1:

- Setpoint at which the liquid solenoid will activate if in solenoid control or if the setting for the control variable for the PID is in liquid motorized value control.

Liquid inj. Setpoint 2:

- Not yet available

Oil Sep. Temp. Override:

- Defines the temperature the oil must reach before the liquid injection solenoid is allowed to be activated.

P = Proportional (Gain):

- Used to adjust the positioning valve in direct proportion to the difference between the control setpoint and the discharge temperature ($\text{SetPt} - \text{DT} = \text{error}$). The proportional term is a unit-less quantity and is used for coarse adjustment. This setpoint should be set to the lowest value that gives adequate response to the control system. Increasing the proportional setting increases the control system's sensitivity to small discharge temperature fluctuations and the tendency to hunt.

I = Integral (reset):

- This parameter integrates the error over time, to account for a small error that has persisted for a long time. This quantity is used for fine adjustment. This setpoint is used to smooth out discharge temperature variations. This setpoint should be set high enough to prevent hunting but not too high or it will cause control system overshoot.

D = Derivative (rate):

- This parameter accounts for how fast the error is changing, positively or negatively.

Minimum Valve Open %:

- When enabled, this is the valve position used whenever the control variable drops below Liquid inj. Setpoint 1. Use only if the compressor is tripping off for low oil temperature due to large overshoots and all other tuning methods have failed.

Avg. with Oil Manifold Temperature:

- When enabled, averages the Oil manifold temperature and the discharge temperature. This creates a more stable control variable and should result in more stable control.

Section 7 • Alarms and Trips

Overview

The Alarms and Trips screen allows the operator to view and adjust settings for compressor safety and alarm settings, see Figure 7-1. Alarms and Trips Screen. Vission 20/20 uses Alarms as a way to notify the operator of running parameters that if left unchecked could result in the compressor shutting down due to a trip. Trips are the conditions that exceed the safety limits of the compressor or refrigeration system and stops the compressor. Trips are always displayed as a red banner and alarms are yellow banners on the top and bottoms status bars. Alarms and trip conditions are also logged to provide an operational history for the operator. Both alarms and trips will be logged in the event list accessible from the menu screen. Trips also trigger the input/output screen to take a snapshot of all input and output values as freeze screen. The freeze screens are available as left side tabs in the input/output screens and are very useful as a troubleshooting tool for the operator.

Alarms and Trips Setpoints

Low Suction Pressure (Alarm & Trip):

- This is the low suction pressure safety. This safety is active in both temperature and pressure control modes. An alarm or trip will be activated if the suction pressure falls below the setpoint values.

High Discharge Pressure (Alarm & Trip):

- This is the high discharge pressure safety. The alarm or trip will be activated if the discharge pressure rises above the setpoint value.

High Process Temperature (Alarm only)

- This alarm is active when the process temperature is at or above the setpoint value. There is no trip setpoint.

Low Process Temperature (Alarm & Trip):

- This is the low control temperature safety. This safety is active when process temperature control has been

The screenshot shows the 'Alarms and Trips' configuration screen. At the top, it displays 'Suction Pressure 1', 'Stopped', and '36.1 Psig Δ'. The main area is a table for setting Alarm and Trip points for four different parameters:

	Alarm	Trip
Low Suction Pressure		
Setpoint No. 1	3.1 "Hg	4.1 "Hg
Setpoint No. 2	1.0 "Hg	2.0 "Hg
High Discharge Pressure		
Setpoint No. 1	210.0 Psig	220.0 Psig
Setpoint No. 2	220.0 Psig	230.0 Psig
High Process Temperature		
Setpoint No. 1	100.0 °F	None
Setpoint No. 2	120.0 °F	None
Low Process Temperature		
Setpoint No. 1	-50.0 °F	-55.0 °F
Setpoint No. 2	-40.0 °F	-45.0 °F

On the right side, there are control elements: 'Capacity Slide' at 0.2%, 'Volume Slide' at 4.7%, and buttons for 'Stop', 'Remote Lock Out', 'Alarm Reset', and 'Unit Start'. Below these are status panels for 'Suction Press Control' (Setpoint 20.0 Psig), 'Suction' (Press 56.1 Psig, Temp 33.3 °F), 'Discharge' (Press 58.1 Psig, Temp 139.1 °F), 'Oil' (Press Diff 1.4 Psig, Filter Diff 0.4 Psig, Inj Temp 118.3 °F, Sep Temp 112.8 °F), and 'Motor' (Amperage 0.0 Amps). At the bottom, there are navigation buttons (Maintenance, User Access, Log off, Help), status bars ('No Scheduled Maintenance', 'No Alarm/Trips Present'), and user information (User Lev2, 08/17/2011 10:50:31, Run Hours 31).

Figure 7-1. Alarms and Trips Screen

Section 7 • Alarms and Trips

selected in the Control Mode dropdown selection found in the Compressor Control screen. An alarm or trip will be activated on a drop in process temperature below the setpoint value.

Low Suction Temperature (Alarm & Trip):

- This is the low suction temperature safety. The alarm or trip will be activated if the suction temperature drops below the setpoint value.

High Discharge Temperature (Alarm & Trip):

- This is the high discharge temperature safety. The alarm or trip will be activated if the discharge temperature rises above the setpoint value.

Low Oil Separator Start Temperature (Alarm & Trip):

- This is the starting low oil separator temperature safety. The compressor is prevented from starting or running if the oil in the separator is below the alarm value. After a time delay (setting of the Oil Separator Temperature Safety Changeover timer), this safety is deactivated and the Low Oil Separator Run Temperature alarm and safety setpoints become active.

Low Oil Separator Run Temperature (Alarm & Trip):

- This is the running low oil separator temperature safety. After a time delay, (setting of the Oil Separator Temperature Safety Changeover timer), the Low Oil Separator Start Temperature is bypassed and Low Oil Separator Run Temperature alarm and safety setpoints become active. The alarm or trip will be activated if the oil temperature in the separator drops below the setpoint value.

Low Oil Injection Temperature (Alarm & Trip):

- This is the low oil injection safety. The alarm and trip setpoints are bypassed at start for a time period (setting of the Oil Injection Temperature Safety Changeover timer). The alarm and trip will be activated after the time delay has expired.

High Oil Injection Temperature (Alarm & Trip):

- This is the high oil injection temperature safety. The alarm or trip will be activated if the oil injection temperature rises above the setpoint value.

Pre-lube Oil Pressure (Alarm & Trip):

- This is the pre-lube oil pump failure safety. If the pre-lube oil pressure does not rise above the alarm setting within 60 seconds for a minimum time set at Minimum Comp. Pre-lube Time, then the start sequence will be aborted. The Minimum Comp. Pre-lube Time is set on the Timer screen. The pre-lube oil pressure is defined as manifold pressure minus discharge pressure. This safety insures adequate lubrication of the the compressor at startup.

Low (Run) Oil Pressure (Alarm & Trip):

- This is the running oil pressure safety. The normal alarm and trip setpoints of this safety are “messed” as soon as the compressor starts. The “Pre lube Oil Pressure” Alarm and Trip setpoints are substituted into this safety setpoints for a time of the “Oil Pressure Bypass” timer (typically 60 seconds). After this timer expires, then the setpoints return back to the normal settings. The action of adjusting the setpoints for about a minute allows the (Run) Oil Pressure to build up to normal running pressures after the compressor starts. After the Oil Pressure Bypass Timer has expired, the Oil Pressure must be above the normal setpoints, or else an Alarm or Trip will occur. An alarm or trip will be active if the oil pressure drops below the normal setpoint values after the Oil Pressure Bypass timer has expired. This time limit is set on the Timer menu screen. Run oil pressure is defined as manifold pressure minus suction pressure.

High Filter Differential Pressure Start (Alarm & Trip):

- This safety allows a higher than normal filter differential pressure to exist during the first minute after a compressor starts. This allows time for cold oil that is present in the oil piping and filters to be passed and replaced with warmer oil. After a time delay (setting of the Filter Diff Pressure Safety Changeover timer), this safety is deactivated and the High Filter Differential Pressure-Run alarm and safety setpoints become active. An alarm or trip will be active if the filter differential (= Filter Inlet Pressure minus Filter Outlet Pressure) exceeds the setpoint value.

High Filter Differential Pressure Run (Alarm & Trip):

- This safety setpoint is active when the compressor has started and the Filter Diff Pressure Safety Changeover timer has timed out. An alarm or trip will be active if the filter differential (= Filter Inlet Pressure minus Filter Outlet Pressure) exceeds by the setpoint value.

High Motor Amps:

- This safety setpoint is active after the Volume Decrease At Start Timer expires (this timer is not settable by the operator). A trip will occur if the motor amperage exceeds the safety setpoint value. For a motor with a 1.15 Service Factor, the trip setpoint should be set at 125% of the motor full load amperage value. The alarm setpoint should be set at 120% of the motor full load amperage value.

Section 7 • Alarms and Trips

Compressor Inhibits

The Vission 20/20 uses several start inhibits to prevent the compressor from starting to protect the compressor and the refrigeration system. While starting the compressor, the inhibits are checked first before the oil pump is started or the motor is started. The failed starts due to an inhibit does not count toward any of the anti-recycle timers including hot starts. The Inhibits uses the alarm setpoint to trigger an aborted start and message. All inhibits will be logged in the event list.

Safety Failure Messages

Low Suction Pressure Trip

- This message will appear when the suction pressure falls below the safety setting of the Low Suction Pressure Trip Setpoint No. 1 or No. 2.

High Discharge Pressure Trip

- This message will appear when the discharge pressure exceeds the safety setting of the Hi Dsch Press Trip Setpoint No. 1 or No. 2.

Low Suction Temp Trip

- This message will appear when the suction temperature falls below the safety setting of the Low Suction Temperature Trip setpoint.

High Discharge Temp Trip

- This message will appear when the discharge temperature rises above the safety setting of the High Discharge Temperature Trip setpoint.

Low Oil Separator Temp Trip

- This message will appear when the Oil Separator Temp is below the Low Oil Separator Start Temp Trip setpoint. In addition this message will appear after the Oil Separator Temp Safety Changeover timer times out and the Oil Separator temperature fails to rise above the Low Oil Separator Start Temp Reset after the compressor is started.

Low Oil Separator Temp Trip

- This message will appear when the Oil Separator Temp is below the Low Oil Separator Run Temp Reset setpoint after the Oil Separator Temp Safety Changeover timer times out.

Low Process Temp Trip

- This message will appear when the Process Control Temperature falls below the safety setting of the Lo Control Temperature Trip Setpoint.

Prelube Oil Pump Inhibit

- This message will appear when the Prelube Oil Pressure (Manifold minus Discharge) has remained below the Prelube Oil Pressure Reset setpoint. The oil pump will try to generate “prelube pressure” for the time period of the Low Oil Pressure Safety Bypass timer setting.

Low Oil Pressure Trip

- This message will appear when the Running Oil Pressure (Manifold minus Suction) has remained below the low Oil Pressure Reset setpoint when the Oil Pressure Bypass Start timer times out. This message will also appear when the Running Oil Pressure falls below the Low Oil Pressure trip setpoint after the Low Oil Pressure Safety Bypass timer times out.

Low Oil Injection Temp Trip

- This message will appear when the Oil Injection temperature falls below the Low Oil Injection Temperature trip setpoint. This message will also appear when the Oil Injection temperature fails to rise above the Low Oil Injection Temperature reset setpoint after the Low Oil Injection Temp Bypass timer times out.

High Oil Injection Temp Trip

- This message will appear when the Oil Injection temperature rises above the High Oil Injection Temperature trip setpoint.

High Filter Differential Trip

- This message will appear if the Filter Differential Pressure rises above the High Fltr Diff Press – Start setpoint before the Filter Differential Pressure Safety Changeover timer times out.

High Filter Differential Trip

- This message will appear if the Filter Differential pressure rises above the High Fltr Diff Press Run setpoint after the Filter Differential Pressure Safety Changeover timer times out.

High Motor Current Trip

- This message will appear if the motor amperage rises above the Hi Motor Amps trip setpoint.

Compressor Interlock Trip

- This message will appear if the Motor Auxiliary contact fails to close before the Compressor Starter Auxiliary Contact Bypass timer times out. Refer to wiring diagram.

High Level Shutdown Trip

- This message will appear when power is removed from the input module that is designated as “Auxiliary #1 Safety” (please refer to your wiring diagram).

Section 7 • Alarms and Trips

False Start

- This message appears when the compressor stops and the motor auxiliary contact fails to open. The message will also appear if the compressor shuts down and the amperage is 20% of the maximum amp setting, indicating that the starter is still energized.

Low Oil Level Trip

- This message appears when power is removed from the designated input module, refer to wiring diagram. This safety will activate only after the oil level has been low for the time period defined by the “Low Oil Separator Safety Trip Delay” timer.

Section 8 • Timers

Overview

The timers screen allows the operator to view and adjust timer settings associated with compressor operation. There are different types of timers that the operator should be aware of listed below, see Figure 8-1. Timers Screen.

Changeover:

- The changeover timers will change from one type control to another once the compressor has started and then the timer has expired.

Bypass:

- The bypass timers prevent certain alarm and trip checks from occurring until the compressor has started and then the time has expired.

Delays:

- Delays require the condition to occur for the specified

amount of time.

Timers:

- A general timer requiring the time to expire before the listed event can occur.

Timer Setpoints

Capacity Increase Start Delay:

- At compressor startup, the capacity slide position is held at minimum position for this time period. This is to allow compressor and system conditions to stabilize. After the timer expires, the slide is free to move in accordance to the system demands.

Minimum Compressor Pre-lube Time:

- This is the length of time the oil pump will run, after establishing Pre-lube Oil Pressure, to prime the oil circuit before starting the compressor.

The screenshot displays the Timers Screen interface. At the top, it shows 'Suction Pressure 1', 'Stopped', and '36.7 Psig Δ'. The main area contains a table of timer settings:

Parameter	Value
Capacity Increase Start Delay	5 sec
Minimum Comp. Prelube Time	5 sec
Low Oil Pressure Safety Bypass	60 sec
High Filter Diff. Press Safety Changeover	60 sec
Oil level #1 Safety Trip Delay	60 sec
Oil level #2 Safety Trip Delay	60 sec
Low Oil Sep. Temp. Safety Changeover	5 min
Low Oil Injection Safety Bypass	6 min

On the right side, there are controls for 'Capacity Slide' (0.2%) and 'Volume Slide' (4.7%), along with buttons for 'Stop', 'Remote Lock Out', 'Alarm Reset', and 'Unit Start'. Below these are sections for 'Suction Press Control' (Setpoint 20.0 Psig), 'Suction' (Press 56.7 Psig, Temp 34.7 °F), 'Discharge' (Press 58.5 Psig, Temp 140.5 °F), 'Oil' (Press Diff 1.4 Psig, Filter Diff 0.5 Psig, Inj Temp 119.7 °F, Sep Temp 114.0 °F), and 'Motor' (Amperage 0.0 Amps). At the bottom, there are navigation buttons (Maintenance, User Access, Log off, Help) and status indicators: 'No Scheduled Maintenance', 'No Alarm/Trips Present', 'User 08/19/2011 01:05:27', and 'Run Hours 31'.

Figure 8-1. Timers Screen

Section 8 • Timers

Low Oil Pressure Safety Bypass:

- This is the length of time in which the normal Low (Run) Oil Pressure setpoints will be adjusted by the values of the Pre-lube Oil Pressure setpoints. After the timer has expired, the normal Low Oil Pressure setpoints become active.

High Filter Differential Pressure Safety Changeover:

- This timer bypasses the High Filter Differential Run Pressure safety settings when the compressor starts. It defines how long the High Filter Differential Start Pressure setpoints will be active after the compressor starts. After the timer has expired, then the High Filter Differential Run Pressure safety setpoints will be active.

Oil Separator Level #1 Safety Trip Delay:

- This timer bypasses the low oil level switch for momentary drops in the oil level. This timer activates when the low oil level switch opens, and deactivates when the switch closes. If the switch is still open after the timer has timed out, the compressor will be shut down and a trip message will be displayed. This timer is available if the unit is equipped with a low oil separator float switch (the oil level switch is standard on all liquid injection units and optional on all others).

Oil Separator Level #2 Safety Trip Delay:

- This timer bypasses the low oil level switch for momentary drops in the oil level. This timer activates when the low oil level switch opens, and deactivates when the switch closes. If the switch is still open after the timer has timed out, the compressor will be shut down and a trip message will be displayed. This timer is available if the unit is equipped with a low oil separator float switch (the oil level switch is standard on all liquid injection units and optional on all others).

Low Oil Separator Temperature Safety Changeover:

- This timer allows Low Oil Separator Start Temperature safety setpoint to protect the compressor against cold oil during starting. After the timer has expired, the Low Oil Separator Run Temperature is then active.

Low Oil Injection Safety Bypass:

- This timer bypasses the Low Oil Injection Temperature Safety setpoint during start-up, to allow any cold oil in the oil lines and filter to pass. After the timer expires, the Low Oil Injection Temperature safety is active.

Max Restart After Power Failure:

- This timer forces the compressor to wait for the set time period after a power failure and the panels re-starts before it can be started automatically. By staggering the time settings of this timer between other compressor panels, the compressors can be allowed to start automatically, one at a time, after a power

failure. This will prevent excessive load demand on the power system that could occur if all of the compressor equipment were to start at the same time. The Power-up Auto Re-Start [x]Enable option must be selected on the Configuration screen for this option to be active.

Hot Starts per Hour:

- This counter counts compressor starts. After every start, a one-hour timer is reset and starts timing. If the timer times out, the hot starts counter is reset. When the counter reaches its preset value, it will not allow another compressor start until the one-hour timer times out and resets the counter. The hot starts counter, therefore, will be reset when the time between compressor starts total one hour. This counter allows repetitive compressor starts, but once the counter has reached its set point, it requires a one-hour window between compressor starts in order for the counter to be reset.

True Anti-Recycle Timer:

- Once the compressor turns off, this timer will keep the compressor off for the setting of the True Anti-Recycle Timer. This timer is used to prevent short cycling of the compressor.

Accumulative Anti-Recycle Timer:

- This timer forces a specified time between compressor starts. When the compressor starts, the timer resets and starts timing and accumulates running time. Once the compressor shuts down, it will not be allowed to restart for the remainder of time left on the Accumulative Anti-Recycle Timer. Unlike the True Anti-Recycle Timer, if the compressor has run for a time period that exceeds the setpoint of the Accumulative Anti-Recycle Timer, then when the compressor shuts down, it will be allowed to restart immediately.

Compressor Interlock Bypass:

- Once the Vission 20/20 has sent a command to the compressor starter to start, a return signal is expected. This timer defines how much time to wait for that signal before setting a trip condition.

High Motor Amps Safety Bypass:

- Starting motors can typically pull much more than its rates full load amps for a short time. This timer ignores that sudden inrush of current for the specified time.

Emergency Stop Timer:

- Defines the amount of time the compressor is in a False start condition before activating the Emergency stop. The emergency stop output can be connected to a shunt-trip in the case of a run away compressor

Section 8 • Timers

to remove all power to the system.

Low Suction Pressure Safety Bypass:

- Sets the time that the compressor is allowed to run at lower suction pressure than would usually be allowed at start up.

High Superheat Temp Safety Changeover:

- This timer activates at shutdown and changes the restart parameters if the time has not been met.

Section 9 • Compressor Scheduling

Overview

This menu allows the operator to schedule control setpoint switching during the day and week. This feature can be enabled and disabled from the Compressor Schedule screen. Up to four setpoint “switch” events can be scheduled per day, see Figure 9-1. Compressor Scheduling Screen.

Scheduling Setpoint

Schedule:

- The options for selection are “Enable” & “Disable”. The operator is allowed to configure setpoints related to schedule events, but only when the schedule is disabled.
- The operator can Enable Compressor Scheduling Feature, only if Time Intervals are in order of Event 1

< Event 2 < Event 3 < Event 4 for all days. If events are not in order, invalid events are marked with caution symbol to indicate the operator to correct events and then enable feature.

Control Mode:

- These drop-down boxes allow selection of operating modes which gets switched once schedule event time is achieved.
- The list of allowable modes depends on the number of controllers selected in the configuration screen. For example, if the number of Suction Pressure Control Setpoints selected is “2” and the number of Process Temperature Control Setpoints selected is “1”, then Control Mode drop-down box will have “Unscheduled”, “Suction Pressure SP1”, “Suction Pressure SP2” and “Process Temperature SP1” as options for selection.
- If Control Mode is selected as “Unscheduled” and Time set in an event is achieved, then control mode will not get switched. Hence Control Mode can be set

The screenshot displays the Compressor Scheduling interface. At the top, it shows 'Suction Pressure 1', 'Stopped', and '19.7 Psig Δ'. The main area is divided into a 'Schedule' section and a 'Control Mode' section. The 'Schedule' section has radio buttons for 'Enabled' and 'Disabled'. Below it is a weekly calendar grid. The 'Control Mode' section lists four 'Schedule Event' entries, each with a 'Control Mode' dropdown (all set to 'Unscheduled') and a 'Time' field (all set to 12:00 AM). To the right, there are 'Capacity Slide' (100.0%) and 'Volume Slide' (13.0%) controls, along with buttons for 'Stop', 'Remote Lock', 'Alarm Reset', and 'Unit Start'. A 'Suction Press Control' section shows a 'Setpoint' of 20.0 Psig. Below that, 'Suction' and 'Discharge' parameters are listed: Suction Press (39.7 Psig), Suction Temp (33.1 °F), Discharge Press (165.1 Psig), and Discharge Temp (125.9 °F). An 'Oil' section shows 'Press Diff' (133.7 Psig), 'Filter Diff' (3.9 Psig), 'Inj Temp' (157.2 °F), and 'Sep Temp' (123.6 °F). At the bottom, there are 'Maintenance', 'Log on', 'Language', and 'Help' buttons. A status bar at the very bottom shows 'No Scheduled Maintenance', 'No Alarm/Trips Present', the date and time '03/02/2010 04:46:29', and 'Run Hours' (0).

Figure 9-1. Compressor Scheduling Screen

Section 9 • Compressor Scheduling

as “Unscheduled” if operator does not want to use all 4 events per day.

Time:

- This setpoint allows selection of Hours, Minutes and AM/PM values for an event. When time set for an event is achieved, control mode will get changed as selected for that event.
- The range of values allowed to set for Hours setpoint is 0 – 12 for 12 hour format and 0 – 23 for 24 hour format. The range of values allowed to set for Minutes setpoint is 0 – 59. AM/PM selection is active for selection only when Time Format selected in configuration screen is 12 hour.

When scheduling feature is enabled and No. of controllers for Suction Pressure Control & Process Temperature Control are changed in configuration screen which makes control modes selected in compressor scheduling screen as invalid, then feature will get disabled automatically and indication will be sent to operator to correct the setting.

Section 10 • Compressor Sequencing

Overview

Compressor sequencing screen is where more than one Vission 20/20 panels can be sequenced in network using Modbus TCP. These settings define how the master compressor should control sequenced Vission 20/20 panels. This feature is enabled from the Configuration Screen, see Figure 10-1. Compressor Sequencing Screen.

Compressor Sequencing:

- Enables Compressor Sequencing. Uncheck the box to disable compressor sequencing.

Master:

- Enables Compressor Sequencing in Master Mode.

Slave:

- Enables Compressor Sequencing in Slave Mode.

Compressor Name:

- Defines Unique name of a Compressor / Vission 20/20 Panel on sequenced network.

Pressure Control Setpoints

Compressor Sequencing screen defines settings those are used by master compressor for sequencing.

Load Rate 2 offset (outer):

- Defines the outer pressure/temp setpoint offset to monitor compressor load. If Suction pressure / process temperature surpasses Load Rate 1 offset and goes beyond Load Rate 2 setpoint offset then sequencing decisions are made according to Load Rate 2 timer.

Load Rate 1 offset (inner):

- Defines the inner pressure/temp setpoint offset to

The screenshot displays the Compressor Sequencing interface. At the top, it shows 'Suction Pressure 1', 'Auto Sequencing', and '-36.3 Psig Δ'. The main configuration table lists equipment (master, slave1, slave2, slave3, None) with their respective control states (ON/OFF), CFM values (483/0), and sequencing steps (1-5) with priority and capacity settings. Below this, 'Machine Start Time' is set to 90 seconds for both start and stop. The 'Advance Sequence Configuration' section includes 'Equalized Load Enable' (unchecked) and 'Sync Sequencing Parameters' (checked). On the right, there are control slides for 'Capacity' (0.0%) and 'Volume' (78.4%), along with buttons for 'Stop', 'Remote Lock Out', 'Alarm Reset', and 'Unit Start'. Real-time data for 'Suction Press Control' (44.0 Psig), 'Suction' (7.9 Psig, 111.0 °F), 'Discharge' (121.5 Psig, 22.3 °F), and 'Oil' (Press Diff 307.6 Psig, Filter Diff 10.7 Psig, Inj Temp 127.5 °F, Sep Temp 118.3 °F) is shown. At the bottom, there are navigation buttons (Maintenance, User Access, Log off, Help) and status indicators: 'No Scheduled Maintenance' and 'No Alarm/Trips Present'. User information (admin, 08/18/2011 04:45:44) and 'Run Hours' (39) are also displayed.

Figure 10-1. Compressor Sequencing Screen

Section 10 • Compressor Sequencing

monitor compressor load. If Suction pressure / process temperature goes beyond Load Rate 1 setpoint offset then sequencing decisions are made according to Load Rate 1 timer.

Suction Pressure/Process Temperature Control Setpoint:

- The target setpoints are read only values here. These setpoints can be changed by logging on to “Compressor Control” Screen.

Unload Rate 1 Offset (inner):

- Defines the inner pressure/temp setpoint to monitor compressor load. If Suction Pressure/Process Temperature Control drops below Unload Rate 1 setpoint offset then sequencing decisions are made according to Unload Rate 1 timer.

Unload Rate 2 Offset (outer):

- Defines the outer Pressure/Temp setpoint offset to monitor compressor load. If Suction Pressure/Process Temperature drops below Unload Rate 1 offset and goes below Unload Rate 2 setpoint offset, then sequencing decisions are made according to Unload Rate 2 timer.

Capacity Load/Unload Timers:

- One of the following Capacity Load/Unload rate timers are used to make sequencing decisions periodically. Suction Pressure/Process Temperature setpoints are monitored to identify which one of the following timers to be used.

Load Rate 1 (Inner):

- If Suction Pressure/Process Temperature goes beyond Load Rate 1 setpoint offset then Load Rate 1 timer is used to make periodic sequencing decisions.

Load Rate 2 (Outer):

- If Suction Pressure/Process Temperature surpasses Load Rate 1 offset and goes beyond Load Rate 2 setpoint offset then Load Rate 2 timer is used to make periodic sequencing decisions.

Unload Rate 1 (Inner):

- If Suction Pressure/Process Temperature goes below Unload Rate 1 setpoint offset then Unload Rate 1 timer is used to make periodic sequencing decisions.

Unload Rate 2 (Outer):

- If Suction Pressure/Process Temperature surpasses Unload Rate 1 offset and goes below Unload Rate 2 setpoint offset then Unload Rate 2 timer is used to make periodic sequencing decisions.

Compressor Sequencing Table:

- Compressor sequencing table menu allows operator to view and adjust settings those are used for compressor sequencing.

Equipment:

- Options of this combo box are updated automatically. This contains names of all the compressors in the network communicating with Master compressor. Equipment name can be selected from drop-down list. Same Equipment name should not be configured more than once in Sequencing table.

Control:

- Inclusion/exclusion of compressor partaking in the sequencing can be decided on basis of this toggle button. Compressors can be included/excluded by toggling ON/OFF.

NOTE

Switching a compressor control to OFF when running in auto seq mode puts respective slave compressor into local auto mode. This feature is used to add or remove slave compressors to sequence table when running in auto sequence mode.

CFM:

- CFM column is read only. These values are updated automatically when Equipment combo box is changed. This indicates Slave compressor capacity in CFM.

Priority:

- This defines priorities of compressors on the network. This priority will decide the sequence in which compressors will be turned on and off during sequence cycle. Lower the priority number greater the priority of the compressor.

Step:

- This parameter would decide stepwise increment or decrement value in percentage of the compressor capacity. In the case when last step makes total capacity greater than maximum capacity, total capacity will get reduced to maximum capacity. Same is applicable when last step makes total capacity lower than minimum capacity takes priority.

Min Cap:

- Defines the lowest capacity in percentage with which a compressor is allowed to run. Minimum capacity value takes preference on first step value.

Max Cap:

- Defines the highest capacity in percentage with which a compressor is allowed to run. Maximum capacity value takes preference over last step value.









Machine Start Time:

- Machine start timer shows the time in seconds that the Master Compressor will hold before starting slave compressor once (Start) decision is taken.

Section 10 • Compressor Sequencing

Status Symbols:

- Status symbols shows status of Slave compressors on the sequencing table. Please see Application Notes for more details.

-  Slave Compressor is detected but is not configured in the sequencing table.
-  Default, If slave Compressor is not present.
-  Slave Compressor is configured in sequencing table but is not configured in “Remote” mode.
-  Slave Compressor configured in sequencing table and is in ready to run state.
-  Slave Compressor is running with Alarm condition.
-  Slave Compressor stopped due to Error Condition.
-  Slave Compressor running at maximum capacity without any error.
-  Slave Compressor under active control of Master Compressor
-  Slave Compressor running into its stop timer, will be stopped.

Machine Stop Time:

- Machine Stop timer shows the time in sec that the Master Compressor will hold before stopping slave compressor once (Stop) decision is taken.

Refresh:

- Compressor Sequencing table is automatically refreshed every 1 minute. Pressing “Refresh” button refreshes the status of the Compressor Sequencing table on Master Compressor.

NOTE

Before Configuring Sequencing table on Master Compressor, log on to slave compressors one by one and enable sequencing in slave mode, put slave in remote mode. Then log on to Master Compressor and wait till all slaves show up their names under equipment List.

Section 11 • Condenser Control

Overview

This screen allows the operator to view and adjust condenser setpoint settings associated with condenser operation. This screen will only be active if the Condenser Control option has been enabled from the Configuration Screen, see Figure 11-1. Condenser Control Screen.

The Condenser Control operation allows the cycling of fans and pumps in order to maintain a specific condensing pressure. The five different steps in step control allow selection of fans, pumps and VFD in one or more steps. When a VFD is employed, VFD is allowed to reach maximum speed, if additional capacity is needed, the next fan or pump is turned on. The VFD will modulate down and then once it is back up to 100% again, then the next fan or pump is turned on. This method allows the smoothest condenser control by spacing the VFD between the fan and pump steps, while maintaining a condenser pressure that matches the setpoint.

Condenser Control Setpoint:

Run Mode:

Run Mode allows the selection of different modes of operation for condenser control. The choices for selection are:

- Run Never - The mode of operation by default. Condenser Control operation will not be performed when this mode is active.
- Run With Comp - Automatic operation of condenser control selected when control of the condenser is required to only run when the compressor is running.
- Run Always - Automatic operation of condenser control selected when control of the condenser is required to run even when the compressor is off.
- Manual - Mode for controlling condenser control operation manually. Operator controls the operation by manual stepping using an on/off toggle button at each step.

The screenshot displays the Condenser Control interface with the following data and controls:

- Top Status:** Suction Pressure 1, Stopped, 36.3 Psig Δ
- Run Mode:** Run Never (selected), Run With Comp, Run Always, Manual.
- Condenser Parameters:**
 - Condenser Press: 132.4 Psig
 - Condenser Setpoint: 120.0 Psig
 - Upper Deadband: 5.0 Psig
 - Lower Deadband: 5.0 Psig
 - Ambient Temp: []
 - Wetbulb Temp: []
 - Wetbulb Offset: 5.0 °F
 - Switch Temp: 32.0 °F
- Profile:** Summer (dropdown), Summer/Winter Auto Switch (checkbox).
- High to Low Speed Fan Delay:** 15 sec, Wettbulb Override (checkbox).
- Step Control Table:**

Steps	Out #1	Out #2	Out #3	Out #4	VFD	Step Delay	Low Speed Fan	Control
<input type="checkbox"/> Step 1	<input type="checkbox"/>	<input type="checkbox"/>	<input type="checkbox"/>	<input type="checkbox"/>	<input type="checkbox"/>	15 sec	None	OFF
<input type="checkbox"/> Step 2	<input type="checkbox"/>	<input type="checkbox"/>	<input type="checkbox"/>	<input type="checkbox"/>	<input type="checkbox"/>	15 sec	None	OFF
<input type="checkbox"/> Step 3	<input type="checkbox"/>	<input type="checkbox"/>	<input type="checkbox"/>	<input type="checkbox"/>	<input type="checkbox"/>	15 sec	None	OFF
<input type="checkbox"/> Step 4	<input type="checkbox"/>	<input type="checkbox"/>	<input type="checkbox"/>	<input type="checkbox"/>	<input type="checkbox"/>	15 sec	None	OFF
<input type="checkbox"/> Step 5	<input type="checkbox"/>	<input type="checkbox"/>	<input type="checkbox"/>	<input type="checkbox"/>	<input type="checkbox"/>	15 sec	None	OFF
- Capacity Slide:** 2.2%, Stop, Remote Lock Out.
- Volume Slide:** 2.7%, Alarm Reset, Unit Start.
- Suction Press Control:** Setpoint 20.0 Psig.
- Suction:** Press 56.3 Psig, Temp 33.1 °F.
- Discharge:** Press 68.3 Psig, Temp 138.7 °F.
- Oil:** Press Diff 11.2 Psig, Filter Diff 1.0 Psig, Inj Temp 118.1 °F, Sep Temp 112.4 °F.
- Motor:** Amperage 0.0 Amps.
- Page:** 1, Menu.
- Navigation:** Maintenance, User Access, Log off, Help.
- Status:** No Scheduled Maintenance, No Alarm/Trips Present.
- User Info:** User 08/19/2011 04:30:22, Run Hours 31.

Figure 11-1. Condenser Control Screen

Section 11 • Condenser Control

Condenser Press:

- This is the read only parameter and it displays the present value of condenser pressure.

Condenser Setpoint:

- This is the condenser pressure setpoint that needs to be maintained.

Upper Deadband:

- This is the condenser pressure setpoint upper deadband value. No additional condenser capacity is added when the condenser is selected for automatic step control and the condenser pressure falls within this deadband.

Lower Deadband:

- This is the condenser pressure setpoint lower deadband value. Condenser capacity is not reduced when the condenser is selected for automatic step control and the condenser pressure falls within this deadband.

Ambient Temp:

- This is the read only parameter and it displays the present value of ambient temperature. This is displayed only when Ambient Sensor is enabled from Configuration Screen.

Wetbulb Temp:

- This is the read only parameter and it displays the present value of wetbulb temperature. This is displayed only when Wetbulb Sensor is enabled from Configuration Screen.

Wetbulb Offset:

- This is the offset value from wetbulb temperature as the override point.

Switch Temp:

- This is the ambient temperature setpoint used for automatic switching of profile from summer to winter and vice-versa.

Profile Selection:

- Profile selection allows operator to have two different output profiles for summer and winter. Operator can have different selection of fans, pumps & VFD in five steps of step control table. Different profiles allow inclusion/exclusion of water pumps in cold weather when summer/winter auto switch is enabled. This selection is inactive when Run mode is Auto and Summer/Winter Auto Switch is enabled.

High to Low Speed Fan Delay:

- This is a time delay for the fan spin down in case of 2-speed motor/dual speed fan.

Summer/Winter Auto Switch:

- This checkbox when enabled allows profiles to switch automatically depending on ambient temperature setpoint when Run Mode is “Auto”. When ambient temperature falls below ambient temperature setpoint, winter profile is used. Similarly when ambient temperature is above ambient temperature setpoint, summer profile is used.

Wetbulb Override:

- This checkbox when enabled gives the operator a functionality to control energy wastage. When the condenser temperature reaches wetbulb temperature plus the operator given offset, then the condenser control operation does not add additional steps. This is done as it is not possible to lower the temperature anymore, and by adding more fans or pumps controls the operation by manually stepping using an on/off toggle button at each step.

Step Control

The Step Control allows the operator to setup the manner in which Fans, Pumps & VFD will be turned on/off. Fans & Pumps are connected on digital outputs Out #1 to Out #4. VFD Fan is connected on Analog Output. Each step can have maximum of five outputs connected to it. Each step can be opted in or out depending on enabling of checkbox, see Figure 11-2. Step Control Screen.

When Run Mode is Auto and condenser pressure rises above upper deadband, condenser step gets incremental from Step 1 to Step 5 and hence switching on/off Pumps, Fans & VFD connected on outputs. This holds true for decremented of steps from Step 5 to Step 1 when condenser pressure falls below lower deadband.

Step Delay:

- Allows operator to set time delays between condenser steps. Condenser Pressure must be outside upper or lower deadband continuously for delay time in order to increase or decrease condenser steps. While in a VFD step, an additional step can only be added once VFD has reached its maximum speed setpoint and the delay timers are satisfied.
- Similarly in a VFD step, a step can only be removed once VFD has reached its minimum speed setpoint and the delay timers are satisfied. Step Delay acts as “ON” timer while loading and acts as “OFF” timer while unloading for the same step.

Low Speed Fan:

- Allows steps to have option for time delay in case of fan spin down. Any of Out #1 to Out #4 can be

Section 11 • Condenser Control

Step Control						Step Delay	Low Speed Fan	Control
Steps	Out #1	Out #2	Out #3	Out #4	VFD			
<input type="checkbox"/> Step 1	<input type="checkbox"/>	<input type="checkbox"/>	<input type="checkbox"/>	<input type="checkbox"/>	<input type="checkbox"/>	15 sec	None	OFF
<input type="checkbox"/> Step 2	<input type="checkbox"/>	<input type="checkbox"/>	<input type="checkbox"/>	<input type="checkbox"/>	<input type="checkbox"/>	15 sec	None	OFF
<input type="checkbox"/> Step 3	<input type="checkbox"/>	<input type="checkbox"/>	<input type="checkbox"/>	<input type="checkbox"/>	<input type="checkbox"/>	15 sec	None	OFF
<input type="checkbox"/> Step 4	<input type="checkbox"/>	<input type="checkbox"/>	<input type="checkbox"/>	<input type="checkbox"/>	<input type="checkbox"/>	15 sec	None	OFF
<input type="checkbox"/> Step 5	<input type="checkbox"/>	<input type="checkbox"/>	<input type="checkbox"/>	<input type="checkbox"/>	<input type="checkbox"/>	15 sec	None	OFF

Figure 11-2. Step Control Screen

selected as Low Speed Fan through combo box. E.g.: Let's say Out #2 is selected as Low Speed Fan in Step 2. When step 2 becomes active during condenser control operation which is after Step 2 time-out delay, Out #2 is left off for time as set by the operator in High to Low Speed Delay. After low speed fan energizes, then timer for Step 3 starts timing.

Control:

- Toggle any of the steps On/Off during Manual operation of Condenser Control. This button is active only when Run Mode selected is Manual. During Auto operation of Condenser Control, control button for active step will be "ON".

VFD Settings

This page is active only when Condenser VFD is selected in Configuration Screen. When a VFD Fan is used for condenser control operation, the speed of the VFD is controlled using PID algorithm.

P = Proportional (gain):

- Used to adjust the fan speed action in direct proportion to the difference between the control setpoint and the process variable ($SP - PV = \text{error}$). The proportional term is a unit less quantity and is used for coarse adjustment. This setpoint should be set to the lowest value that gives adequate control system response. Increasing the proportional setting increases the control system's sensitivity to small process fluctuations and the tendency to hunt.

I = Integral (reset):

- Used to adjust the capacity control action, integrating the error over time, to account for a small error that has persisted for a long time. This quantity is used for fine adjustment. This setpoint is used to

smooth out process variations. This setpoint should be set high enough to prevent hunting but not too high or it will cause control system overshoot.

D = Derivative (rate):

- Used to adjust the capacity control action, accounting for how fast the error is changing, positively or negatively.

Maximum Speed:

- This setpoint defines the maximum speed in percentage for Condenser VFD Fan at which it should run for continuous step delay time to increase condenser steps. E.g. let's say setpoint is kept at 95%. Then condenser VFD fan will have to run at speed of 95% or more to advance to next step. Maximum Speed can be set as 100%, which is when analog output (at which condenser VFD fan is connected) reaches to 20mA in its normal range of 4-20 mA

Minimum Speed:

- This setpoint defines the minimum speed in percentage for Condenser VFD Fan at which it should run for continuous step delay time to decrease condenser steps. E.g. let's say setpoint is kept at 5%. Then condenser VFD fan will have to run at speed 5% or less to advance to next step. Minimum Speed can be set as 0%, which is when analog output (at which condenser VFD fan is connected) reaches 4mA in its normal range of 4-20 mA.

Section 12 • Service Options

Overview

The Service Option screen allows the operator the ability to force individual digital or analog outputs ON. This feature is used for diagnostic purposes during initial setup and/or if the operator suspects an issue with the outputs. The buttons in this screen are not available while the compressor is running, see Figure 12-1 Service Options Screen.

Digital Outputs

The digital output buttons are momentary toggle buttons. The output will be active while the operator has his finger on the button. The output will deactivate when the operators finger is removed. The operator can measure the output at the terminal block or view the output by watching the LEDs located on the cards.

Compressor Start:

- Activates the output assigned to the compressor motor starter. The output is connected to terminal 11 and is the 1st LED on card 1.

Oil Pump Start:

- Activates the output assigned to the oil pump. The output is connected to terminal 12 and is the 2nd LED down on card 1.

Capacity Increase Motor:

- Activates the output assigned to the increase input of the capacity actuator. The output is connected to terminal 13 and is the 3rd LED down on card 1.

Capacity Decrease Motor:

- Activates the output assigned to the decrease input of the capacity actuator. The output is connected to terminal 14 and is the 4th LED down on card 1.

Volume Increase Motor:

- Activates the output assigned to the increase input

The screenshot displays the Service Options screen with the following components:

- Top Bar:** Suction Pressure 1, Stopped, 36.1 Psig Δ
- Digital Outputs Table:**

Output Name	Status
Compressor Start	OFF
Oil Pump Start	OFF
Capacity Increase Motor	OFF
Capacity Decrease Motor	OFF
Volume Increase Motor	OFF
Volume Decrease Motor	OFF
Oil Separator Heater	OFF
Alarm	ON
- Capacity Slide:** 0.0% with Stop, Remote Lock Out, and Unit Start buttons.
- Volume Slide:** 0.0% with Alarm Reset button.
- Suction Press Control:** Setpoint 20.0 Psig
- Suction:** Press 56.1 Psig, Temp 33.3 °F
- Discharge:** Press 57.8 Psig, Temp 139.3 °F
- Oil:** Press Diff 1.1 Psig, Filter Diff 0.6 Psig, Inj Temp 118.1 °F, Sep Temp 113.1 °F
- Motor:** Amperage 0.0 Amps
- Page Navigation:** Page 1, 2, 3, 4, Menu
- System Status:** Maintenance, User Access, Log off, Help, No Scheduled Maintenance, No Alarm/Trips Present, User 08/19/2011 03:50:22, Run Hours 31

Figure 12-1. Service Options Screen

Section 12 • Service Options

of the volume actuator. The output is connected to terminal 15 and is the 5th LED down on card 1.

Volume Decrease Motor:

- Activates the output assigned to the decrease input of the volume actuator. The output is connected to terminal 16 and is the 6th LED down on card 1.

Oil Separator Heater

- Activates the output assigned to the oil separator heater. The output is connected to terminal 17 and is the 7th LED down on card 1.

Trip:

- Deactivates the output during a trip or inhibit condition. This is a reverse acting output. The output is connected to terminal 18 and is the bottom LED on card 1.

Slide Valve Setpoint # 1 (Economizer):

- Activates the output typically assigned to the economizer solenoid, but can be changed by the operator. The output is connected to terminal 21 and is the 1st LED on card 2.

Slide Valve Setpoint # 2 (Hot Gas Bypass):

- Activates the output typically assigned to the hot gas bypass solenoid, but can be changed by the operator. The output is connected to terminal 22 and is the 2nd LED on card 2.

Alarm:

- Activates the output during an alarm condition. This is a reverse acting output. The output is connected to terminal 23 and is the 3rd LED on card 2.

Liquid Injection # 1:

- Activates the output assigned to the liquid injection solenoid. The output is connected on terminal 25 and is the 5th LED on card 2.

Liquid Injection # 2:

- Not currently enabled

Remote Enabled:

- Activates the output assigned to notify a central control system of the Vission 20/20 run status. The output is connected to terminal 27 and is the 7th LED on card 2.

Shunt Trip:

- Activates the output during a false start condition and the emergency stop timer has expired. This output could be wired the a breaker with a shunt trip that feeds power to a starter to force a shutdown. The output is connected to terminal 28 and is the 8th LED on card 2.

Condenser Step # 1:

- Activates the output assigned to the 1st step of the condenser. The output is connected to terminal 41 and is the 1st LED on card 4.

Condenser Step # 2:

- Activates the output assigned to the 2nd step of the condenser. The output is connected to terminal 42 and is the 2nd LED on card 4.

Condenser Step # 3:

- Activates the output assigned to the 3rd step of the condenser. The output is connected to terminal 43 and is the 3rd LED on card 4.

Condenser Step # 4:

- Activates the output assigned to the 4th step of the condenser. The output is connected to terminal 44 and is the 4th LED on card 4.

Analog Outputs

The Analog Output (AO) selections allow the operator to enter a desired value of the output then turn on the output. The operator will have to measure the output using meter capable of measuring a 4-20mA signal.

Compressor VFD:

- Sets the analog output assigned to the compressor VFD. The output is connected to AO #1 on card 10.

Condenser VFD:

- Sets the analog output assigned to the condenser VFD. The output is connected to AO #2 on card 10.

% Slide Valve Position

- Sets the analog output assigned to the Slide Value position used to inform a central control system of the capacity position. The output is connected to AO #3 on card 10.

Liquid injection Motorized Valve:

- Sets the analog output assigned to the liquid injection motorized value position. The output is connected to AO #4 on card 10.

Section 13 • Instruments Calibration

Overview

The Instrument Calibration screen allows the operator to define how the Vission 20/20 will interpret the signal from any devices attached to the panel's analog inputs. The instrument calibration screen is organized up to six pages. Each page is then divided into several left side selected tabs. Each tab will be headed with an information bar labeled "I/O" that give the basic information for that device. The "A/D bit Value" display box shows the unmodified value read by the Vission 20/20 analog to digital converters. This display box is not affected by any changes to the calibrations settings. As long as a device is connected to the associated input, there will be a value in this display box. The "Calibrated Value" display box shows the end result of the calibration process. Therefore, any changes to the calibration setpoint will effect what value is shown, see Figure 13-1 Instruments Calibration Screen.

All instruments are calibrated using a two point linear

calibration process. Any device that has a non-linear response to environmental stimuli will not be able to be calibrated through the Vission 20/20.

Pressure and Temperature Inputs

The most commonly used instruments are temperature and pressure sensors. The first two pages of the Instrument Calibration screen are dedicated to these instruments.

Each tab on these two pages are divided into two sections, Device Calibration and Channel Calibration. The device calibration section is where the operation parameters of the instrument is defined. The channel calibration defines the type of signal sent by the instrument.

Default Devices:

- By selecting this option, the operator will have access via a drop-down box of several common devices. The

The screenshot displays the 'Suction Pressure 1' calibration screen. At the top, it shows 'Stopped' and '37.5 Psig Δ'. The main area is divided into 'Analog Inputs' (with a list of inputs like Suction Press, Discharge Press, etc.), 'I/O' (showing A/D bit Value: 1383 and Calibrated Value: 57.5 Psig), 'Device Calibration' (with 'Default Devices' selected and a dropdown menu), and 'Channel Calibration' (with 'Offset' and 'Range' settings). On the right, there are 'Capacity Slide' (0.2%) and 'Volume Slide' (4.7%) controls, along with buttons for 'Stop', 'Remote Lock Out', 'Alarm Reset', and 'Unit Start'. Below these are status panels for 'Suction Press Control' (Setpoint: 20.0 Psig), 'Suction' (Press: 57.5 Psig, Temp: 36.0 °F), 'Discharge' (Press: 59.1 Psig, Temp: 140.9 °F), 'Oil' (Press Diff: 0.9 Psig, Filter Diff: 0.6 Psig, Inj Temp: 120.6 °F, Sep Temp: 114.7 °F), and 'Motor' (Amperage: 0.0 Amps). At the bottom, there are navigation buttons (Maintenance, User Access, Log off, Help) and a status bar showing 'No Scheduled Maintenance', 'No Alarm/Trips Present', 'User: 08/19/2011 10:49:52', and 'Run Hours: 31'.

Figure 13-1. Instruments Calibration Screen

Section 13 • Instruments Calibration

devices are predefined and if one is selected, then all the setpoints will be set for the operator.

Custom Device:

- This option allows the operator to choose the minimum and maximum value of the instrument being used.

Offset:

- Once the two point calibration is completed, it is not uncommon for there to be a small error. By entering the value of the error from the calibrated value and the actual value into the adjustment entry box, that error will be added/subtracted from the total offset. The offset is applied to the calibrated value which should correct the error.

Range:

- This option is available when the custom device option is chosen. Here the operator defines the signal type and range transmitted by the instrument. The operator can choose from several predefined ranges in the drop-down box or enter a value.

Motor Current

The Vission 20/20 has two options for measuring motor current. A 4-20mA signal transmitted from an external device or a 0-5Amp AC current Transformer. The type of device being used is selected in the configuration screen.

The motor current tab has the ability to calibrate both measurement options through the 4-20mA scale and current transformer ratio sections. However, the device type that is selected in the configuration screen will be the only section that will be available to the operator.

The calibration differs from all other calibration procedures in that the motor current must be calibrated while the compressor is running at close to full load amps as possible. In addition, the operator will need to enter a value into the “Enter Desired Value” entry box that is equal to the measured value in amps by a calibrating measurement device. After entering the measured value, the displayed motor current may still be off slightly. In this case reenter the desired value and the displayed value should get progressively closer.

4-20mA Scale:

- 4mA:
 - Not editable by the operator. Defines the minimum value in amps represented by a 4ma inputs.
-

- 20mA:
 - Defines the maximum value in amps represented by a 20ma inputs.
- Enter Desired Value:
 - The operator enters the correct current value. Each entry will recalculate the point-slope calculations of the current calibration.
- Total Error:
 - Not editable by the operator. Displays the total error offset of entries from the “Enter Desired Value” setpoint.

Current Transformer Ratio:

- Primary
 - Defines the upper value of the current transformer.
- Secondary:
 - Not editable by the operator. Defines the minimum value of the current transformer.
- Enter Desired Value:
 - The operator enters the value of the correct current value. Each entry will recalculate the point-slope calculations of the current calibration.
- Total Error:
 - Not editable by the operator. Displays the total error offset of entries from the “Enter Desired Value” setpoint

Remote Capacity

The remote capacity input allows a system controller such as the PLC to control the capacity position during direct I/O control.

Control Input:

- This drop-down box is not used at this time.

Scale:

- Defines the minimum and maximum Capacity position between 0% & 100% for the 4-20ma input.

Offset:

- Used to correct any error in the capacity position. By entering a value into the Adjustment entry box, that value will be added to the total offset displayed in the “total offset” entry box.

Section 13 • Instruments Calibration

Analog Inputs

This section of the Calibration screen allows the operator to define the parameters of an installed auxiliary analog instrument. These instruments are usually not part of a typical compressor setup but Vission 20/20 provides a way for the operator to add additional capabilities. The layout of this screen is typical to the pressure and temperature calibration screens.

Device Calibration:

- These setpoints allow the operator to define what the input from the auxiliary instrument means in terms of units and range. If a temperature measuring instrument is connected, then the operator would select temperature from the Unit drop-down box then set the maximum and minimum value for the scale.

Offset:

- Once the two-point calibration is completed, it is not uncommon for there to be a small error. By entering the value of the error from the calibrated value and the actual value into the adjustment entry box, that error will be added/subtracted from the total offset. The offset is applied to the calibrated value which should correct the error.

Range:

- Here the operator defines the signal type and range transmitted by the instrument. The operator can choose from several predefined ranges in the drop-down box or enter a value.

Section 14 • Slide Calibration

Overview

The Slide Calibration screen is used in calibrating the slide actuators and to establish Vission 20/20 control parameters. It is important that the operator uses caution while operating in this screen, see Figure 14-1. Slide Calibration Screen. The normal safety checks that prevent the slide from colliding with the mechanical stops are overridden. When the calibration process is completed and the operator exits the screen, Both actuator will return the slides back to their minimum positions.

Capacity Slide Valve Potentiometer

This section provides critical information and control parameters related to the capacity slide actuator. The “% cap” display shows the actual value in percent of the capacity slide with out any conditioning that might be applied to the other capacity position displays. In addition,

this section displays the value of the actuator signals in millivolts in the “input Value” display box.

“-” Button:

- When the operator presses and holds this button, the output associated with capacity slide decrease is energized. If the actuator does not turn in the correct direction when this button is pressed, then the operator will have to alter how the actuator is wired to the panel.

“+” Button:

- When the operator presses and holds this button, the output associated with capacity slide increase is energized. If the actuator does not turn in the correct direction when this button is pressed, then the operator will have to alter how the actuator is wired to the panel.

Software limit setpoint:

- The Vission 20/20 uses the “Min Limit” and “Max Limit” setpoint to define an area within the

The screenshot displays the Slide Calibration interface with the following components:

- Top Status Bar:** Suction Pressure 1, Stopped, 37.5 Psig Δ
- Analog Inputs:**
 - Suction Press
 - Discharge Press
 - Oil Filter In Press
 - Oil Manifold Press
 - Condenser Press
 - Economizer Press
- I/O Section:**
 - A/D bit Value: 1383
 - Calibrated Value: 57.5 Psig
- Device Calibration:**
 - Default Devices (selected)
 - Range: 0-414.5 psia (4-20ma)
 - Min: -14.7 Psig
 - Max: 400 Psig
- Channel Calibration:**
 - Offset Adjustment: 0
 - Range: 4ma - 20ma
 - Min: 4 ma
 - Max: 20 ma
- Control Buttons:** Stop, Remote Lock Out, Alarm Reset, Unit Start
- Slide Status:** Capacity Slide (0.2%), Volume Slide (4.7%)
- Suction Press Control:** Setpoint 20.0 Psig
- Suction:** Press 57.5 Psig, Temp 36.0 °F
- Discharge:** Press 59.1 Psig, Temp 140.9 °F
- Oil:** Press Diff 0.9 Psig, Filter Diff 0.6 Psig, Inj Temp 120.6 °F, Sep Temp 114.7 °F
- Motor:** Amperage 0.0 Amps
- Page Navigation:** Page 1, 2, 3, 4, 5, 6, Menu
- System Status:** Maintenance, User Access, Log off, Help
- Alerts:** No Scheduled Maintenance, No Alarm/Trips Present
- User Info:** User 08/19/2011 10:49:52, Run Hours 31

Figure 14-1. Slide Calibration Screen

Section 14 • Slide Calibration

mechanical stops for normal slide travel. These software limits purpose is to prevent the slide from actually hitting the mechanical stops which could result in a number of undesirable consequences. By default, the software limits are set to 150mV from either end point. The position percentage is calculated from the software limits. Therefore, it is possible to read a value greater than 100% or less than 0% if inertial carries the slides after these limits are reached.

Volume Slide Valve Potentiometer

- This section provided critical information and control parameters related to the volume slide actuator. The “% Vol” display shows the actual value in percent of the volume slide with out any conditioning that might be applied to the other volume position displays. In addition, this section displays the value of the actuator signals in millivolts in the “input Value” display box.

“-” Button:

- When the operator presses and holds this button, the output associated with volume slide decreases is energized. If the actuator does not turn in the correct direction when this button is pressed, then the operator will have to alter how the actuator is wired to the panel.

“+” Button:

- When the operator presses and holds this button, the output associated with volume slide increase is energized. If the actuator does not turn in the correct direction when this button is pressed, then the operator will have to alter how the actuator is wired to the panel.

Software limit setpoint:

- The Vission 20/20 uses the “Min Limit” and “Max Limit” setpoint to define an area within the mechanical stops for normal slide travel. These software limits purpose is to prevent the slide from actually hitting the mechanical stops which could result in a number of undesirable consequences. By default, the software limits are set to 150mV from either end point. The position percentage is calculated from the software limits. Therefore It is possible to read a value greater than 100% or less than 0% if inertial carries the slides after these limits are reached.

Slide Valve Operation

The slide valve actuator is a gear-motor with a position sensor. The motor is powered in the forward and reverse

directions from the main computer in the control panel. The position sensor tells the main computer the position of the slide valve. The main computer uses the position and process information to decide where to move the slide valve next.

During calibration, the position sensor records the high and low count of motor turns. The operator tells the position sensor when the actuator is at the high or low position with the push button. Refer to the calibration instructions for the detailed calibration procedure.

The position sensor can get “lost” if the motor is moved while the position sensor is not powered. To prevent this, the motor can only be moved electrically while the position sensor is powered. When the position sensor loses power, power is cut to the motor. A capacitor stores enough energy to keep the position sensor circuitry alive long enough for the motor to come to a complete stop and then save the motor position to non-volatile EEPROM memory. When power is restored, the saved motor position is read from EEPROM memory and the actuators resumes normal function This scheme is not foolproof. If the motor is moved manually while the power is off or the motor brake has failed, allowing the motor to free wheel for too long after the position sensor loses power, the actuator will loose its calibrated position.

A brake failure can sometimes be detected by the position sensor. If the motor never stops turning after a power loss, the position sensor detects this, knows it will be lost, and goes immediately into calibrate mode when power is restored.

Slide Valve Actuator Calibration for Optical Style Motors

Assuming that the actuator motors have not been calibrated, the transmitter output of the actuator motor will fluctuate wildly until they are calibrated. To prevent damage to actuator motors, do not connect the Power Cable (Yellow TURCK cable) or the Position Transmitter Cable (Gray TURCK cable) until instructed to do so in this procedure.

1. Open the plastic cover of the capacity motor by removing the four #10 Pan Head Phillips screws. Gently lift the cover and tilt it toward the TURCK connectors. Raise the cover enough to be able to press the blue calibrate button and to be able to see the red LED on the top of the assembly, see Figure 14-2. Photochopper.
2. Remove actuator motor cover(s).
3. Log In on the Vission 20/20.

Section 14 • Slide Calibration

4. From the main screen select the Menu button.
5. On the menu screen select the Slide Calibration button. When the “Slide Valve Calibration” screen appears, then you can safely connect the Power Cable (Yellow TURCK cable) and the Position Transmitter Cable (Gray TURCK cable) to the Capacity motor. Press “+” or “-” to move the slide valves to check the rotation. (See Table 1 below for proper shaft rotation). If for any reason the “+” or “-” command on the panel does not correspond to the slide increase or decrease, swap the blue & brown wires of the Yellow TURCK cable in the control panel to reverse the rotation of the motor.

CAUTION

DO NOT CONTINUE TO ENERGIZE THE ACTUATOR MOTOR AFTER THE SLIDE HAS REACHED THE MECHANICAL STOP. Doing so may cause mechanical damage to the motor or shear the motor shaft key. When the slide has reached the mechanical stop position, press the button in the center of the photochopper to release the brake, and thereby release the tension on the actuator motor.

6. Quickly press and release the BLUE CALIBRATION BUTTON on the ACTUATOR motor once. This instructs the ACTUATOR motor to enter the calibration mode. The red LED on the actuator control board will begin flashing. Use the “-” button on the Vission 20/20 panel to drive the capacity slide to its minimum mechanical stop position.

This will be apparent by a slowing of the motor rotation and a winding sound from the actuator motor. When you hear the motor wind-up, release the “-” button.

Then use the “+” button to pulse the motor so that the capacity slide is “just off” of its minimum position and there is no tension on the motor shaft.

7. Quickly press and release the BLUE CALIBRATION BUTTON on the ACTUATOR motor once. The red LED will now flash at a slower rate. This now instructs the ACTUATOR motor that this point is the minimum slide position. This point will correspond to 0 volts AFTER the ACTUATOR calibration procedure is completed.

8. Use the “+” button on the Vission 20/20 to drive the capacity slide to its maximum mechanical stop position. This will be apparent by a slowing of the motor rotation and a winding sound from the actuator motor. When you hear the motor wind-up, release the “+” button.

9. Quickly press and release the BLUE CALIBRATION BUTTON on the ACTUATOR motor once. The RED LED will stop flashing. This now instructs the ACTUATOR motor that this point is the maximum slide position. This point corresponds to 5 volts. The ACTUATOR calibration procedure is completed.

Now the Capacity Channel is automatically calibrated based on the calibration settings made to the actuator.

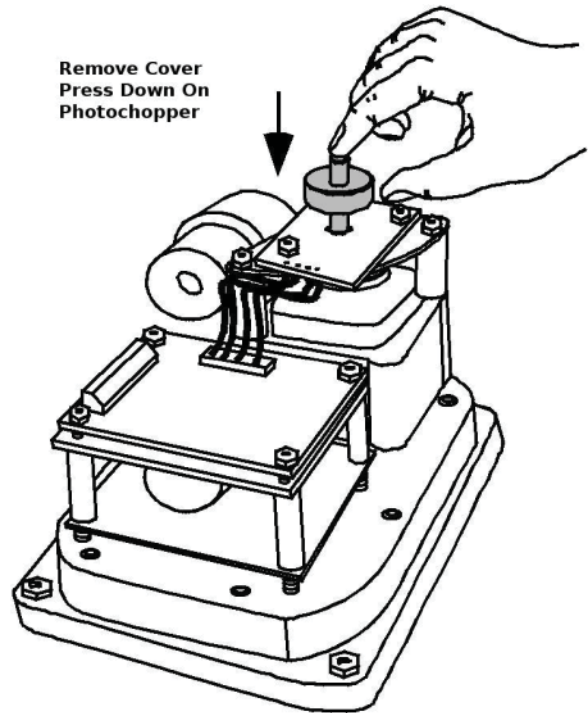

Figure 14-2. Photochopper

CAUTION

Do not over tighten screws. Failure to comply may result in damage to equipment.

10. Gently lower the plastic cover to where it contacts the base and O-ring seal. After making sure that the cover is not binding, gently tighten the four # 10 Phillips screws.

11. Repeat the same procedure for the Volume slide motor.

Section 14 • Slide Calibration

Command Shaft Rotation

The following table describes the rotation direction required by the actuator. Every optical actuator has the ability to be wired to rotate in either direction. Energizing the blue actuator wire results in a CCW rotation and energizing the brown wire results in a CW rotation, see Table 14-1. Command Shaft Rotation Required By Actuator.

Table 14-1. Command Shaft Rotation Required By Actuator

Compressor Model Number	Command Shaft Rotation			
	Capacity		Volume	
	Increase	Decrease	Increase	Decrease
71	CW	CCW	CW	CCW
91	CW	CCW	CW	CCW
101	CW	CCW	CW	CCW
111	CW	CCW	CW	CCW
151	CW	CCW	CW	CCW
181	CW	CCW	CW	CCW
201	CW	CCW	CW	CCW
211	CW	CCW	CW	CCW
291	CW	CCW	CW	CCW
301	CW	CCW	CW	CCW
341	CW	CCW	CW	CCW
361	CW	CCW	CW	CCW
401	CW	CCW	CW	CCW
451	CW	CCW	CW	CCW
501	CCW	CW	CCW	CW
601 (VSM)	CW	CW	CCW	CW
601 (VSS)	CW	CCW	CW	CCW
701	CCW	CW	CCW	CW
751	CCW	CW	CCW	CW
791	CCW	CW	CCW	CW
891	CCW	CW	CCW	CW
901	CCW	CW	CCW	CW
1051	CCW	CW	CCW	CW
1201	CCW	CW	CCW	CW
1501	CCW	CW	CCW	CW
1551	CCW	CW	CCW	CW
1801	CCW	CW	CCW	CW
1851	CCW	CW	CCW	CW
2101	CCW	CW	CCW	CW
2401	CCW	CW	CCW	CW
2601	CCW	CW	CCW	CW
2801	CCW	CW	CCW	CW
3001	CCW	CW	CCW	CW

Section 14 • Slide Calibration

Slide Valve Troubleshooting Guide

The Analog output card of the Vission 20/20 produces a 4–20mA signal to any attached devices. However, it is not uncommon that small differences in the board components might result in small differences in the output. So this screen offers the operator the ability to fine tune the upper and lower output values, see Table 14-2. Slide Valve Troubleshooting Guide.

Table 14-2. Slide Valve Troubleshooting Guide (1 of 2)

Problem	Reason	Solution
The actuator cannot be calibrated.	Dirt or debris is blocking one or both optocoupler slots.	Clean the optocoupler slots with a cotton swab and rubbing alcohol.
	The photochopper fence extends less than about half way into the optocoupler slots.	Adjust the photochopper so that the fence extends further into the optocoupler slots. Make sure the motor brake operates freely and the photochopper will not contact the optocouplers when the shaft is pressed down.
	The white calibrate wire in the grey Turck cable is grounded.	Tape the end of the white wire in the panel and make sure that it cannot touch metal.
	Dirt and/or condensation on the position sensor boards are causing it to malfunction.	Clean the boards with an electronics cleaner or compressed air.
	The calibrate button is stuck down.	Try to free the stuck button.
	The position sensor has failed.	Replace the actuator.
The actuator goes into calibration mode spontaneously.	Push button is being held down for more that $\frac{3}{4}$ second when going through the calibration procedure.	Depress the button quickly and then let go. Each $\frac{3}{4}$ second the button is held down counts as another press.
	The white calibrate wire in the grey Turck cable is grounding intermittently.	Tape the end of the white wire in the panel and make sure that it cannot touch metal.
	A very strong source of electromagnetic interference (EMI), such as a contactor, is in the vicinity of the actuator or grey cable.	Increase the distance between the EMI source and the actuator. Install additional metal shielding material between the EMI source and the actuator or cable.
The actuator does not transmit the correct position after a power loss.	The motor was manually moved while the position sensor was not powered.	Recalibrate.
	The motor brake is not working properly.	Get the motor brake to where it operates freely and then recalibrate.
	The position sensor's EEPROM memory has failed.	Replace the actuator.
There is a rapid clicking noise when the motor is operating.	The photochopper is misaligned with the slotted optocouplers.	Try to realign or replace the actuator.
	The motor brake is not working properly.	Get the motor brake to where it operates freely and then recalibrate.

Section 14 • Slide Calibration

Table 14-2. Slide Valve Troubleshooting Guide (2 of 2)

Problem	Reason	Solution
There is a rapid clicking noise when the motor is operating. (Continued)	The position sensor's EEPROM memory has failed.	Replace the actuator.
There is a rapid clicking noise when the motor is operating.	The photochopper is misaligned with the slotted optocouplers.	Try to realign or replace the actuator.
	The photochopper is positioned too low on the motor shaft.	Adjust the photochopper so that the fence extends further into the optocoupler slots.
	A motor bearing has failed.	Replace the actuator.
The motor operates in one direction only.	There is a loose connection in the screw terminal blocks.	Tighten.
	There is a loose or dirty connection in the yellow Turck cable.	Clean and tighten.
	The position sensor has failed.	Replace the actuator.
	There is a broken motor lead or winding.	Replace the actuator.
The motor will not move in either direction.	The thermal switch has tripped because the motor is overheated.	The motor will resume operation when it cools. This could be caused by a malfunctioning control panel. Consult the factory.
	Any of the reasons listed in "The motor operates in one direction only".	See above.
	The command shaft is jammed.	Free the command shaft.
	Broken gears in the gear-motor.	Replace the actuator.
The motor runs intermittently, several minutes on, several minutes off.	Motor is overheating and the thermal switch is tripping.	This could be caused by a malfunctioning control panel. Consult the factory.
The motor runs sporadically.	Bad thermal switch.	Replace the actuator.
	Any of the reasons listed in "The motor will not move in either direction".	See above.
The motor runs but output shaft will not turn.	Stripped gears inside the gear rotor, or the armature has come unpressed from the armature shaft.	Replace the actuator.

Section 14 • Slide Calibration

Slide Valve Actuator Troubleshooting Guide Blink Code

Vilter actuators communicate problems discovered by the internal diagnostics to the technician by LED blink codes. Only one blink code is displayed, even though it is possible that more than one problem has been detected. The actuator motor will not operate until the error code is cleared by pressing the blue bottom, see Table 14-3. LED Blink Codes and Troubleshooting Guide.

Table 14-3. LED Blink Codes and Troubleshooting Guide (1 of 2)

Flash Pattern * = ON - = OFF	Meaning
* _ * _ * _ * _ * _ * _ * _ * _	Calibration step 1.
* _ _ _ * _ _ _ * _ _ _ * _ _ _	Calibration step 2.
* _ _ * _ _ _ _ _ _ _ _ _ _ _ _ _ _	<p>This indicates a zero span. This error can only occur during calibration. The typical cause is forgetting to move the actuator when setting the upper limit of the span. If this is the case, press the blue button to restart the calibration procedure. This error can also occur if either or both of the slotted optocouplers are not working. If this is the case, the slide valve actuator will have to be replaced.</p> <p>The operation of the slotted optocouplers can be tested as follows:</p> <ol style="list-style-type: none"> 1. Manually rotate the motor shaft until the aluminum photochopper fence is not blocking either of the optocoupler slots. 2. Using a digital multimeter, measure the DC voltage between terminal 3 of the small terminal block and TP1 on the circuit board (see Note 1). The measurement should be between 0.1 and 0.2 Volts. 3. Next, measure the DC voltage between terminal 3 and TP2 on the circuit board. You should measure between 0.1 and 0.2 Volts.
* _ _ _ _ _ _ _ _ _ _ _ _ _ _ _ _ _ _	<p>A motor over-speed occurred. At some time during operation, the motor armature spun too fast for the encoder to measure. A nonfunctional motor brake is usually to blame. This error means that the slide valve actuator is no longer transmitting accurate position information. The actuator should be recalibrated as soon as possible, after the cause of the over-speed is identified and corrected. This error will not clear until the actuator is re-calibrated.</p>

Note 1: TP1 and TP2 are plated-thru holes located close to the slotted optocouplers on the board. They are clearly marked on the board silkscreen legend.

Section 15 • Trend Chart

Overview

This screen allows the operator to view and adjust settings for the trend chart, see Figure 15-1. Trend Chart Screen. Trending feature can be started & stopped from this screen. Up to four variables can be selected for plotting on screen. Each variable is assigned one of four colors; the plotted trace and the vertical axis labels for a variable will be in its assigned color. The operator can select from viewing the plot to selecting which variables and time intervals to show as often as necessary. The vertical axis scaling and offset for each variable plotted is based on its range of values over the entire data plotted on screen. The data available for display is 120 hours maximum.

Chart Operation

Pen Selection:

- Pen selection allows operator to select different pens for plotting of data on the screen. The operator can select “None” as an option for disabling plotting of data for particular pen. Options in pen selection drop-down box will depend on channels selected in Trend Setup screen.

Start/Stop:

- This button allows the operator to start/stop trend feature. When trend feature is not running, button will display “Start” and will be green in color. While trend feature is running, button will display “Stop” and will be red in color. When “Stop” button is pressed, trend data is saved to a file.

Zoom In/Out:

- These buttons allow the operator to adjust the number of data points plotted on the screen. At maximum

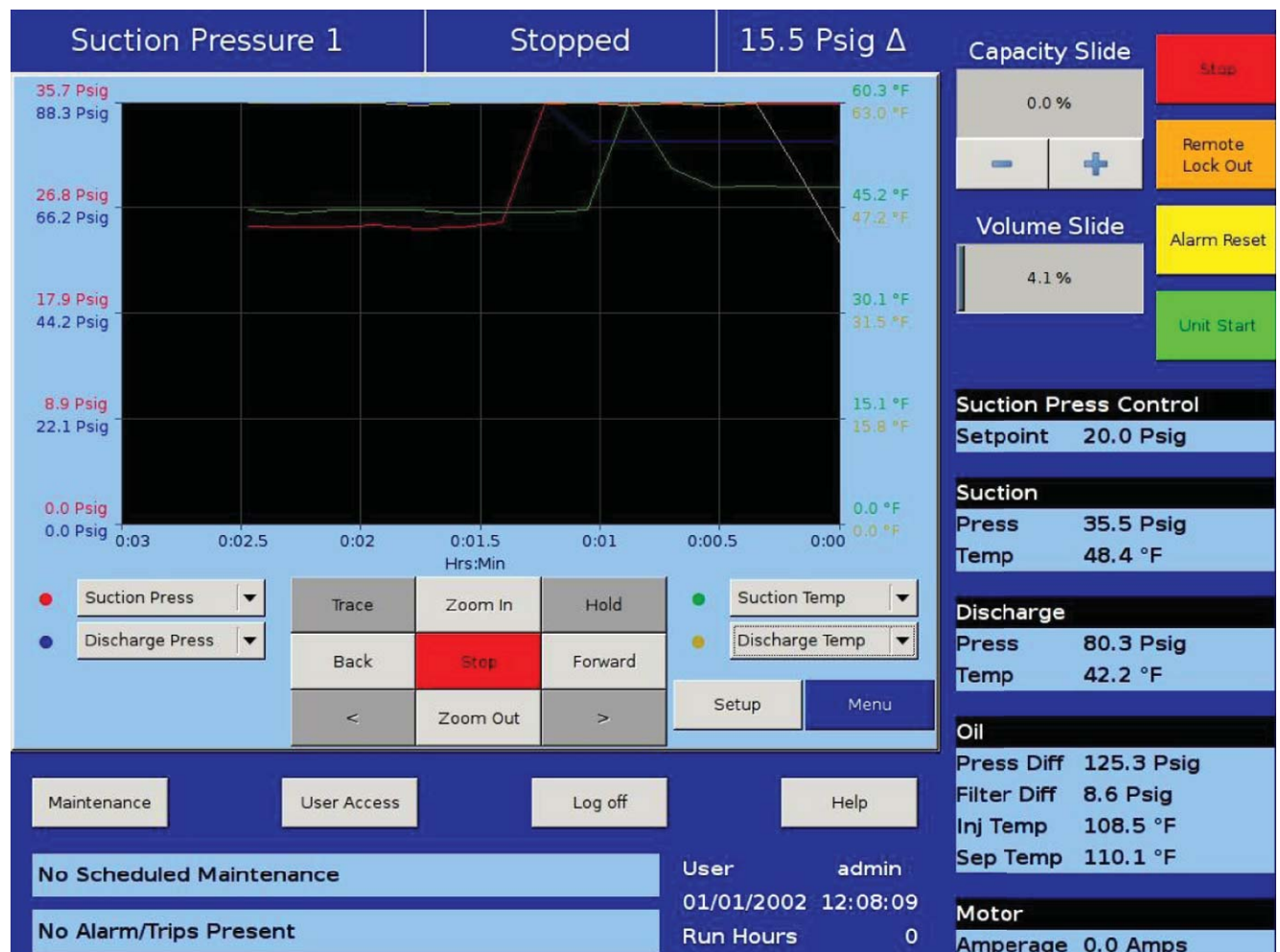

Figure 15-1. Trend Chart Screen

Section 15 • Trend Chart

zoom level operator can view 3 minutes of trend data and Zoom In button will be inactive. At minimum zoom level operator can view full 120 hours of trend data and Zoom Out button will be inactive.

Back/Forward:

- These buttons allow the operator to move the plot and view trend data at different time intervals.
- Forward button will be inactive when the operator is viewing the first data point plotted on the screen (i.e. when time interval is displaying 0:00). Back button will be inactive when the operator is viewing the last data point on the screen (i.e. when time interval is displaying 120:00). At minimum zoom level, Back & Forward buttons will be inactive.

Trace:

- This button allows the operator to move a white cursor line across all four trend lines and receive a read-out of all four variables at that point in time. When the Trace button is pressed, cursor position is displayed along with value of all four variables on the screen.

Hold:

- This button allows the operator to stop the data from advancing on the display without stopping the trend feature. When the Hold button is pressed, Hold Time is displayed on the screen.

Trace Back(<) / Forward (>):

- These buttons allow the operator to move a white cursor line across trend lines and view trend data value at that point. These buttons will only be active when Trace button is pressed. When these buttons are pressed, cursor is moved and trace position is updated on the screen.

Setup:

- This button allows operator to open the Trend Setup screen. This button is inactive when the trend feature is running.

Trend Data Storage

The trend analysis screen shows recorded data for problem analysis or tuning improvements. A logging buffer holds 5 minutes of data sampled at 10 second intervals.

When the logging buffer fills with 5 minutes of data, it is automatically transferred to a temp csv file. A temp trend file will hold up to 1MB of accumulated data. When the temp file has accumulated 1MB of data, data from temp file is written to new trend file and temp file is overwritten with new data in logging buffer till next 1MB of data. When a total of 15MB of trend data is accumulated, and the logging buffer has filled with another 5 minutes of data to write, the file with the oldest trend data is deleted.

Section 15 • Trend Chart

Setup

The operator can modify options for pen selection drop-down box from trend setup screen, see Figure 15-2. Trend Setup Screen.

Trend setup screen will appear on press of Setup button when trending feature is not running. Trend Setup screen allows the operator to select a maximum of 10 analog I/O channels for trending. The operator can also set a path for trend data files from the drop-down box in the setup screen. The USB will appear as an option in drop-down box only when a USB drive is mounted on the panel.

If there is no space available on the USB or when the USB is unmounted from the panel and USB is selected for saving trend files, trend data files will be written to hard disk.

If the operator changes Press/Temp units from configuration screen when trending feature is running, then background trending is stopped.

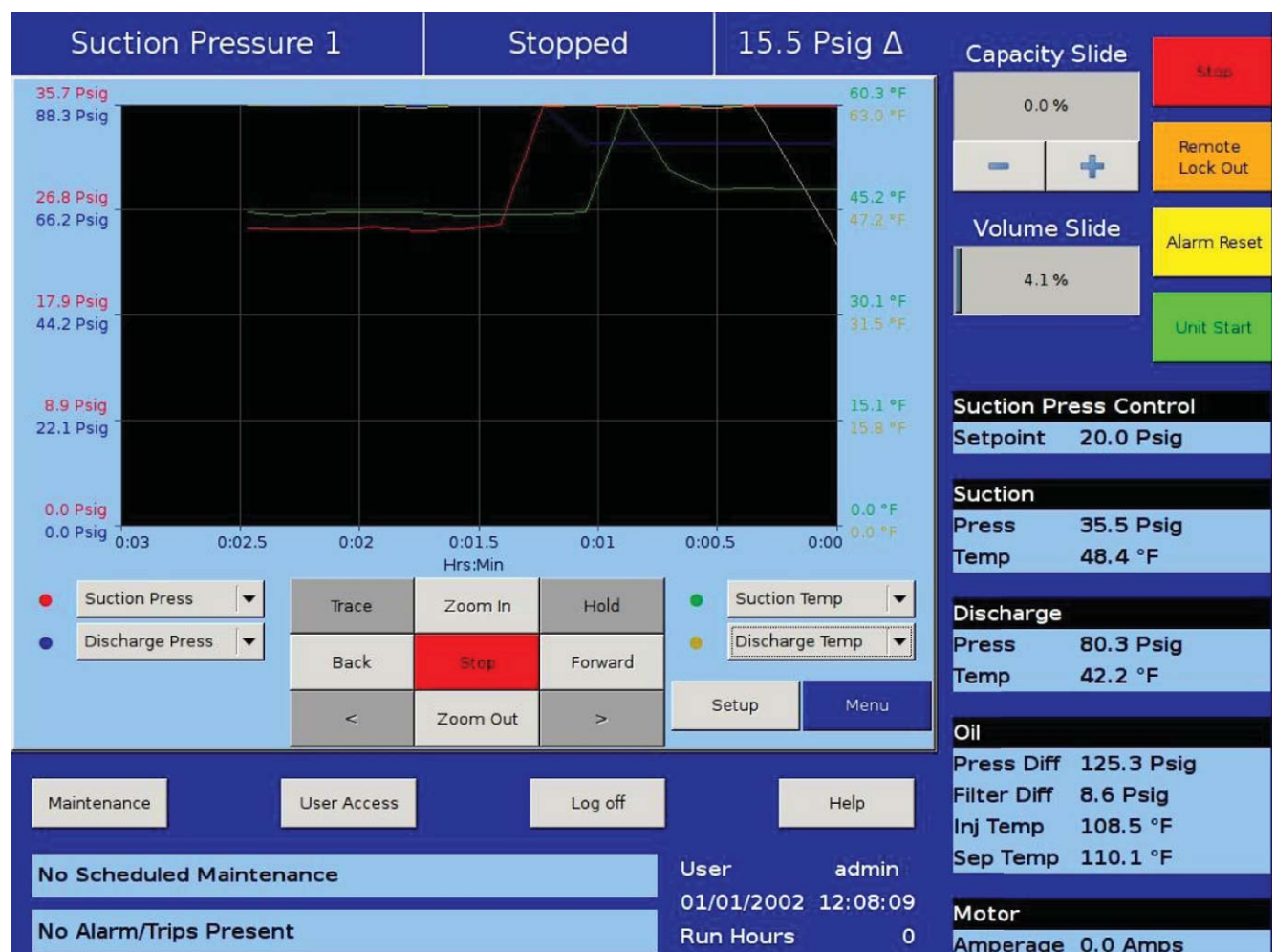

Figure 15-2. Trend Setup Screen

Section 16 • Event List

Overview

This screen is designed to display compressor events in chronological order. The information available on the screen is valuable for understanding the operation of the compressor and troubleshooting, see Figure 16-1. Event List Screen. This screen is divided into four columns and can list up to 128 separate events. The operator can download the information on the event list through the Data Backup Screen.

Event list Columns

Date:

- Displays the date of the event in MM-DD-YYYY format.

Time:

- Displays the time of the event in HH:MM:SS format.

Event Type:

- Displays the type of message for a particular listing. Common type are “Start”, “Stop”, “Trip”, “Inhibit”, “Alarm”, and “System”. These help the operator to understand the meaning of the message in the next column.

Message:

- Displays the informational string that describes the event.

The screenshot displays the Event List Screen with the following components:

- Header:** Suction Pressure 1, Stopped, 35.9 Psig Δ
- Event List Table:**

Date	Time	Event Type	Message
08-19-2011	03:53:06 PM	System	Power Up
08-19-2011	03:52:18 PM	System	Power Up
08-19-2011	03:51:47 PM	System	Power Up
08-19-2011	03:50:55 PM	System	Power Up
08-19-2011	03:50:08 PM	System	Power Up
08-19-2011	03:48:39 PM	Stop	Stopped
08-19-2011	03:25:04 PM	Start	Auto
08-19-2011	03:25:04 PM	Alarm	Remote Comm Time-out
08-19-2011	03:21:05 PM	Start	Remote
08-19-2011	02:25:46 PM	System	Power Up
08-19-2011	02:24:22 PM	System	Power Up
08-19-2011	02:22:12 PM	System	Power Up
08-19-2011	02:21:06 PM	System	Power Up
08-19-2011	02:20:06 PM	System	Power Up
08-19-2011	02:19:01 PM	System	Power Up
08-19-2011	02:18:20 PM	System	Power Up
08-19-2011	02:17:40 PM	System	Power Up
08-19-2011	01:15:01 PM	System	Power Up
- Control Panels:**
 - Capacity Slide:** 0.0% (Stop, Remote Lock Out buttons)
 - Volume Slide:** 0.0% (Alarm Reset, Unit Start buttons)
 - Suction Press Control:** Setpoint 20.0 Psig
 - Suction:** Press 55.9 Psig, Temp 33.8 °F
 - Discharge:** Press 57.7 Psig, Temp 137.7 °F
 - Oil:** Press Diff 1.0 Psig, Filter Diff 0.5 Psig, Inj Temp 115.8 °F, Sep Temp 110.8 °F
 - Motor:** Amperage 0.0 Amps
- Bottom Bar:** Maintenance, User Access, Log off, Help, Update, Menu, No Scheduled Maintenance, No Alarm/Trips Present, User 08/19/2011 03:53:24, Run Hours 31

Figure 16-1. Event List Screen

Section 17 • Input / Output

Overview

This screen displays “Live Data” of all the analog points and digital points being monitored, see Figure 17-1. Input/Output Screen. There are four pages of Input / Outputs (I/O) available for viewing. This screen also takes a snapshot of all the I/O points if the compressor experiences a trip condition and saves this data as Freeze pages. Up to five Freeze pages can be saved. The oldest Freeze page will be removed when more than five Freeze events occur. These Freeze events can be downloaded to a USB drive through the Data Backup screen.

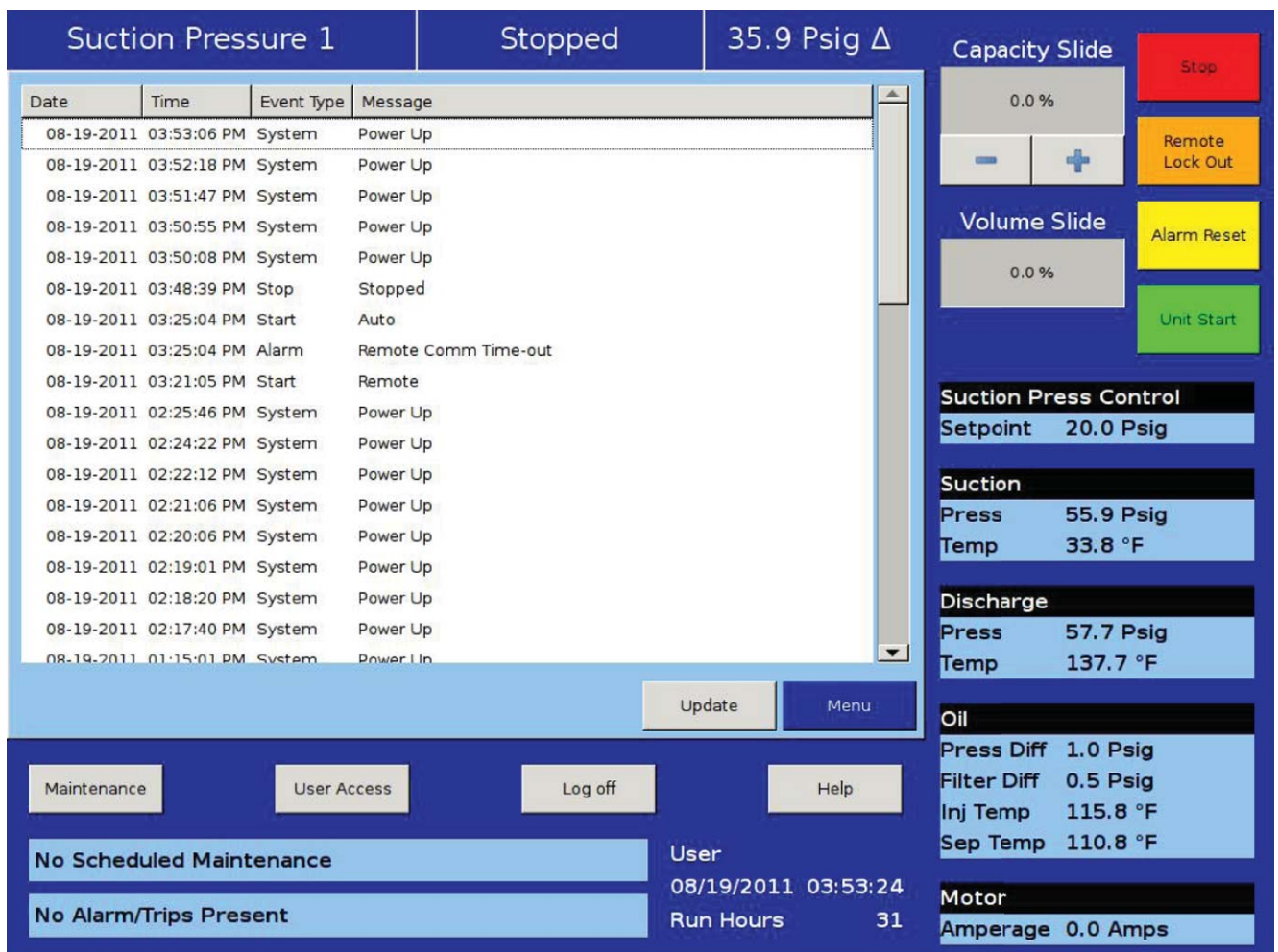

Figure 17-1. Input/Output Screen

Section 18 • Auxiliary Input / Output

Overview

The Auxiliary Input/Output (I/O) section of the Vission 20/20 gives the operator flexibility to add peripheral instruments and/or devices such as motors, valves and solenoids. With these additions, customer configurable I/Os are useful in expanding the functions of the Vission 20/20 where it was not explicitly designed to control, see Figure 18-1. Auxiliary Input/Output Screen.

Setting up one or more of the auxiliary inputs or outputs start with the configuration screen. In order to enable the auxiliary I/O, the Vission 20/20 must first be equipped with one of the available expandable I/O cards and the card must be selected on page 6 of the configuration screen. Once the appropriate card is available, then the operator will be permitted to enable and name the desired auxiliary I/O. The operator can then navigate to the Auxiliary I/O screen where the operator can define how that I/O will operate.

Digital Inputs:

The Digital Inputs section of the auxiliary I/O allows an operator to configure the auxiliary digital inputs. The digital input can be configured to produce an alarm, a trip, and an inhibit on either a high or low input. A low input is 0vac and a high is 120vac on the enabled input. Leaving all options in their default setting will mean no action will be taken on an enable input. The input will simply be available for viewing at the panel or by communications.

Trip/Alarm Check:

- Selecting this checkbox enables the alarms and/or trip functions of the Vission 20/20 for the desired digital input. The accompanying drop-down box gives the operator the flexibility to choose whether the alarm and/or tip occurs if the input is high or low.

The screenshot displays the Auxiliary Input/Output configuration screen. At the top, it shows 'Suction Pressure 1' at 'Stopped' with a value of '22.0 Psig Δ'. The main area is divided into two columns for 'Analog Aux out 1' and 'Analog Aux out 2'. Each column has radio buttons for 'Standard Input' (selected) and 'Auxiliary Input', a dropdown for 'Active Input' (set to 'None'), and a 'Run Always' checkbox. Below these are 'Trigger' settings with radio buttons for 'Analog Input' (selected) and 'Digital Input', a dropdown for 'Trigger Input' (set to 'None'), and a dropdown for 'Enable If Above / O' (set to 'O'). 'Trigger Value' is 0.0 and 'Differential' is 2.0. The 'Control Method' section has radio buttons for 'PID Control' and 'Scalable Control' (selected), with input fields for P (Gain), I (Reset), and D (Rate), and a 'Setpoint' field. Min and Max input/output values are also set. On the right, there are 'Capacity Slide' (0.0%) and 'Volume Slide' (4.7%) with minus and plus buttons, and buttons for 'Stop', 'Remote Lock Out', 'Alarm Reset', and 'Unit Start'. Below the slides are status sections for 'Suction Press Control' (Setpoint 20.0 Psig), 'Suction' (Press 42.0 Psig, Temp 45.0 °F), 'Discharge' (Press 88.1 Psig, Temp 63.2 °F), 'Oil' (Press Diff 119.0 Psig, Filter Diff 8.5 Psig, Inj Temp 108.5 °F, Sep Temp 110.1 °F), and 'Motor' (Amperage 0.0 Amps). At the bottom, there are navigation buttons (Page 1-7, Menu), 'Maintenance', 'User Access', 'Log off', and 'Help' buttons. A status bar shows 'No Scheduled Maintenance' and 'No Alarm/Trips Present', along with user information: 'User Vilter', '01/07/2002 11:00:36', and 'Run Hours 0'.

Figure 18-1. Auxiliary Input/Output Screen

Section 18 • Auxiliary Input / Output

Inhibit Check:

- Selecting this checkbox enables the inhibit function of the Vission 20/20 for the desired digital input. An inhibit check prevents the compressor from starting if the condition is true where a trip will shut down the compressor after it as started. The inhibit can be selected to inhibit on a high or low input and can be selected to work with or without the alarm and trip function

Digital Outputs

The digital outputs section of the Auxiliary I/O screen allows an operator to configure the auxiliary digital outputs. The digital output can be configured to activate (go High, 120vac) based on either a digital input or a specified level on an analog input. Every digital and analog input in the Vission 20/20 are made available for controlling a digital output.

Analog Input:

- Selecting the Analog Input radio button fills the Active Input drop-down box with all available analog inputs. One of the analog inputs can then be selected to control the digital outputs.

Digital Input:

- Selecting the Digital Input radio button fills the Active Input drop-down box with all available digital inputs. One of the digital inputs can then be selected to control the digital outputs.

Run Always:

- Selecting this checkbox enables the function that controls the digital output to operate only when the compressor is running or runs all the time.

Analog Trigger:

- The analog trigger toggles the digital output based on a specified value plus the specified differential value.
- Analog Trigger value:
 - This defines the specified value in which the output will toggle. This is an absolute value and not based on units. For example, 100 could mean temperature or pressure depending on the type of input selected.
- N/O & N/C:
 - Choosing the Normally Open (N/O) or Normally Closed (N/C) radio buttons defines what the output will be above or below the trigger value. In the N/O setting, the output will be

off (0vac) while the input value is below the trigger value.

- Differential:
 - This is the differential around the trigger value. For example, if a trigger value of 100 is entered with a differential of 1, then as the value increases to 101, the output will be triggered. If the value decreases to 99, then the output will be toggled in the opposite direction.

Digital Relay:

- The digital relay option is used to pass along the information from a digital input to another control device or to operate a peripheral device. This output can be configured to either reflect the selected input or show the opposite value.
- Mirror:
 - Selecting this option will produce a high output when the selected input is High; and produce a low output when the selected input is low.
- Invert:
 - Selecting this option will produce a low output when the selected input is high; and produce a High output when the selected input is low.

Analog Inputs

The Analog inputs section of the auxiliary I/O screen allows an operator to define the function of an instrument connected to the Vission 20/20. The analog inputs can be configured to simply monitor an input for informational purposes or used as a control input for the auxiliary digital and analog outputs. The analog inputs can also be configured to alarm, trip, and inhibit on specified values.

- Alarm / Trip:
 - This drop-down box allows the operator to select whether the analog input should generate an alarm, trip, or both when the input value exceeds the limits entered into the alarm and trip entry boxes.
- Inhibit:
 - Selecting this checkbox will prevent a start if the input value exceeds the alarm limit values.
- Low Alarm:
 - This defines the lower limit of the input value that when exceeded will generate an alarm.

Section 18 • Auxiliary Input / Output

- High Alarm:
 - This defines the upper limit of the input value, that when exceeded will generate an alarm.
- Low Trip:
 - Defines the lower limit of the input value that when exceeded will generate a trip.
- High Trip:
 - Defines the upper limit of the input value that when exceeded will generate a trip.

Analog Outputs

This screen allows to map any standard analog input or auxiliary input to any of the four analog auxiliary outputs. There are two pages of auxiliary output configuration, each consists of two analog auxiliary outputs.

- Active Input:
 - Active Input can be selected from available standard analog inputs or auxiliary inputs. Selected Active Input gets mapped to auxiliary output.
- Run Always:
 - “Run Always” option can be selected to enable mapped auxiliary output irrespective of the compressor’s run state. If “Run Always” is not selected then the mapped auxiliary output is enabled only when compressor is running.
- Trigger:
 - Trigger configuration is used to enable / disable auxiliary output according to the configured trigger input. Trigger input can be selected from available standard analog inputs , auxiliary analog inputs or digital inputs. Trigger value and differential in combination with trigger type (“enable if above / On” or “enable if below / Off”) enables or disables auxiliary output.

Control

Auxiliary outputs can be PID Controlled or Scalable Controlled.

P = Proportional (gain):

- Used to adjust the auxiliary output in direct proportion to the difference between the control setpoint and the active input . The proportional term is a unit less quantity and is used for coarse adjustment. This

setpoint should be set to the lowest value that gives adequate control system response. Increasing the proportional setting increases the control system’s sensitivity to small process fluctuations and the tendency to hunt.

I = Integral (reset):

- Used to integrate the error over time, to account for a small error that has persisted for a long time. This quantity is used for fine adjustment. This setpoint is used to smooth out process variations. This setpoint should be set high enough to prevent hunting but not too high or it will cause control system overshoot.

D = Derivative (rate):

- Used to account for how fast the error is changing, positively or negatively.

Scalable Control:

- Minimum Input / Maximum Input:
 - These setpoints defines minimum and maximum Input range for configured active input .
- Minimum Output / Maximum Output:
 - These setpoints defines minimum and maximum output. The Auxiliary output produces a linear value based on these settings.

Section 19 • Configuration

Overview

The configuration screen is where most of the Vission 20/20 features are enabled and configured, see Figure 19-1. Configuration Screen - Page 1. The initial Setup of the Vission 20/20 will generally start here. Depending on what is selected, different portions of the Vission 20/20 will be available to the operator.

Units

This section sets how values will be represented through out the program.

Temp Units:

- Drop-down box to select the temperature units from Fahrenheit and Celsius. Once selected, all screen temperatures will be displayed in the chosen units.

Press Units:

- Drop-down Box to select the pressure units. Psig, Bar, and Kpa are the possible selections and the units will be displayed for every pressure value throughout the screens.

Order Num:

- Identifies the Order number of the purchase of the compressor. This Number will be needed if the operator requires help from Vilter.

Run Hours:

- Offers the ability to change the compressor run hours. This is typically used when replacing an older micro controller on an existing compressor with a new Vission 20/20.

Time & Date

This section sets the time and date of the Vission 20/20. Accurate time and date are accentual for accurate

The screenshot shows the configuration interface for the Vission 20/20 compressor. It is organized into several functional areas:

- Units:** Temp. Units (°F), Press. Units (Psig), Order Num. (1), Run Hours (31).
- Time & Date:** Time Format (24 hour, 12 hour), Current (Hour: 01, PM, Minute: 06, Second: 46), Date (Year: 2011, Month: 08, Day: 19).
- Communications:** Active Remote Control (Ethernet), Direct I/O --> Auto Capacity (checked), Serial (Modbus RTU) (unchecked), Ethernet (checked). Settings include Panel ID (1), Port (P12 / RS485), Baud Rate (9600), Data Bits (8), Stop Bits (1), Parity (Even), IP Address (192.168.1.98), Subnet Mask (255.255.255.0), Gateway (192.168.1.1), and Protocol (Modbus TCP).
- Touchscreen:** Calibrate button.
- Anti-Recycle:** Hot Starts (dropdown menu).
- Restart on Power Failure:** Radio buttons for Always, Never, Timed, Remote Lock Off, and Boot in Remote (Direct I/O).
- Compressor Sequencing:** Radio buttons for Master and Slave, Compressor Name (None).
- Language:** English (dropdown menu).

At the bottom, there is a Page navigation bar (1-6) and Apply/Close buttons.

Figure 19-1. Configuration Screen - Page 1

Section 19 • Configuration

logging and troubleshooting. Setting these parameter will set the hardware clock embedded in the Vission 20/20 CPU. If the time is not retained after powering down the panel, the operator should check and/or replace the coin style battery on the panel SBC behind the touchscreen.

Format:

- Selection to choose between 12 hour or 24 hours clock.

Hour:

- Entry box to set the clock hours. AM or PM drop-down box will available if the 12 hour format is selected.

Minute:

- Entry Box to set the clock minutes.

Second:

- Entry Box to set the clock seconds.

Year:

- Entry Box to set the current year.

Month:

- Entry Box to set the current month.

Day:

- Entry Box to set the current date.

Communications

The communication section is the control center for all communications to the Vission 20/20 panel. It is possible to have multiple modes of communications enabled and used. However, only one mode can be used to control the Vission 20/20 which is selected in the “Active Remote Control” drop-down box. For a complete list of communication registers, please refer to the Vission 20/20 communication table.

Active Remote Control:

- Selects the mode of remote control. The operator can select between Direct I/O, Serial, or Ethernet.

Direct I/O:

- Enables the Direct I/O inputs. Once selected a pop-up will be displayed and the operator will need to choose a one of the three Direct I/O options

Serial (Modbus RTU):

- Enables the Serial Modbus RTU protocol. Once selected, the remainder of the serial setpoints will be available for editing.

Panel ID:

- Panel Identifier used by the controller when communicating with multiple panels.

Port:

- The Vission 20/20 has two ways to communicate on serial bus. Either via the built in serial port, P12, or through one of the USB ports. This drop-down box allows the operator to chose which one will be used.

Baud Rate:

- Sets the Baud Rate for the serial communication.

Data Bits:

- Fixed at 8 Data bits.

Stop Bits:

- Identifies the end of character for re-synchronizing.

Parity:

- Identifies the type of error detection.

Ethernet:

- Enables the Ethernet port. Once selected, the remainder of the Ethernet setpoints will be available for editing.

Panel ID:

- Panel Identifier used by the controller when communicating with multiple panels.

IP Address:

- Entry box to set the IP address.

Subnet Mask:

- Entry box to set the Subnet Mask.

Gateway:

- Entry box to set the Gateway address.

Protocol:

- Drop-down box to select the type of protocol used to remotely control the Vission 20/20.

Touchscreen

The “Calibrate” button changes the screen into touchscreen calibration mode. Calibrating the touchscreen is only required if the operator finds that the pointer arrow no longer follows his finger. The calibration mode requires the operator to touch the four corners of the touchscreen and then the accept button.

Anti-Recycle

Anti-Recycle defines the method of motor protection

Section 19 • Configuration

due to repeated motor starts. The operator has 3 choices of protection. Hot starts allows only a certain number of starts per hour before setting an hour to the anti-recycle timer. The number of starts is set in the timer page. Accumulative immediately adds time to the anti-recycle timer once the compressor is started and the time can be set in the timers screen. True anti-recycle adds to the anti-recycle timer once the compressor is shutdown. The motor of the compressor can not be restarted as long as there is anti-recycle time left and the operator can view this time on the top left corner of the main screen.

Restart On Power Failure

This feature of the Vission 20/20 offers the ability to define how the Vission 20/20 will handle a power failure. This can also be useful to allow system controller to regain control of the Vission panel without the need for operator intervention.

Always:

- When selected, initiates a start after the panel powers back up after a power failure, but only if the compressor was running before the power failure and starts the compressor in Auto mode.

Never:

- When selected, prevents any automatic action once the panel powers back up after a power failure.

Timed:

- When selected, initiates a start after the panel powers back up after a power failure and the operator set timer runs out. When there are multiple compressor in a larger system, it is recommended that the operator gives each compressor a different start times. A restart will only occur if the compressor was running before the power failure and starts the compressor in Auto mode.

Remote Lock Off:

- When selected, turns the remote lock out off when the panel powers up. Select this option if the operator wishes a system controller to regain control of the Vission 20/20 without human interference.

Boot in Remote (Direct I/O)

- When selected, places the panel into remote mode when the panel powers up. Select this option when under direct I/O control and the system controller is to gain control of the Vission 20/20 without human interference.

Compressor Sequencing

The compressor sequencing is a feature of the Vission 20/20 that allows the operator to setup as many as five compressor to automatically start, stop and maintain system loads. The compressor that is designated as the master will monitor systems parameter and make decisions on how many compressor are required to meet the load as efficiently as possible.

Compressor Sequencing:

- Enables the compressor sequencing algorithms and allows access to the compressor sequencing screen.

Master:

- Identifies the panel as the master while in sequencing control.

Slave:

- Identifies the panel as a slave while in sequencing control.

Compressor Name:

- Unique identifier that is broadcasted to all other Vission 20/20 units in the sequencing network.

Language

Allows the operator to select the language in which all screens will be displayed in.

Model & Refrigerant

The values in this section provides the Vission 20/20 algorithm critical information on how to efficiently and safely control the compressor, see Figure 19-2. Configuration Screen - Page 2.

Compressor:

- Drop-down box to select the compressor type. This selection is critical for proper volume slide control.

Model:

- Drop-down box to select the compressor size. This selection is critical for proper volume slide control.

Refrigerant:

- Drop-down box to select the type of refrigerant. This selection is critical for proper volume slide control.

Other (K-Factor):

- Optional setting to adjust volume slide control.

Section 19 • Configuration

Compressor Control

Vilter compressors typically run in one of two control modes, suction pressure or process temperature control, see Figure 19-2. Configuration Screen - Page 2.

Suction Pressure Control:

- This defines the suction pressure input as the process variable and all controls will be based on suction pressure. The operator has the option to select up to two controllers where each can have its own set of setpoints.

Process Temp. Control:

- This defines the process temperature input as the process variable and all controls will be based on the process temperature. The operator has the option to select up to two controllers where each can have its own set of setpoints.

Optional Function Selection

The following options are additional features of the Vission 20/20 that can be selected. Some of these options will not be available for selection unless the proper I/O cards are installed and enabled, see Figure 19-2. Configuration Screen - Page 2.

Compressor VFD:

- Enables the compressor motor VFD option.

% Slide Volume Position:

- Unused.

Economizer Pressure:

- Enables the economizer pressure input.

Superheat Monitor:

- Enables the superheat safety algorithms.

Compressor: VSM
Model: 501
Refrigerant: R717 - Cool Comp
Other (K-Factor): 1

Compressor Control # Controllers

Suction Pressure Control 1
 Process Temp. Control 1

Optional Function Selection

Compressor VFD
 % Slide Volume Position
 Economizer Pressure
 Superheat Monitor

Condenser Control

Ambient Sensor
 Wetbulb Sensor
 VFD Fan

Superheat

T-SAT vs. Oil Sep. Temp: 1 °F
T-SAT vs. Oil Sep. Temp Delay: 1 sec
T-SAT vs. Disch. Temp: 1 °F
T-SAT vs. Disch. Temp Delay: 1 sec

Oil Pump

No Pump
 Cycling
 Full Time
Pumps: 1
 Cool Compression

Oil Cooling

Thermosyphon
 H2O Oil Cooler
 Liquid Injection
 Solenoids 1
 Motorized Valve
 Cool Compression

Separator Velocity

Factor 1: 1
Factor 2: 1
Factor 3: 1

Motor Current Device

Current Transformer
 4-20ma Transmitter

Page: 1 2 3 4 5 6 Apply Close

Figure 19-2. Configuration Screen - Page 2

Section 19 • Configuration

Condenser Control

The values in this section enables the condenser control feature of the Vission 20/20. Once selected the checkboxes will become available for selection and the condenser control screen will be available via the menu screen. Some of the options check boxes in this section may not be available for selection unless the proper I/O cards are installed and enabled, see Figure 19-2. Configuration Screen - Page 2.

Ambient Sensor:

- Enables the ambient temperature option for the condenser control algorithm.

Wetbulb Sensor:

- Enables the wetbulb temperature override option for the condenser control algorithm.

VFD Fan:

- Enables the VFD output option for the condenser control algorithm.

Oil Pump

This section defines how the Vission 20/20 will control the oil pump, see Figure 19-2. Configuration Screen - Page 2.

No Pump:

- Disables all functions for oil pump control.

Cycling:

- Enables option for cycling oil pump. Oil pump is cycled on and off depending on compressor differential pressure.

Full Time:

- Enables option for full time oil pump. Oil pump will always be running while the compressor is running.

Pumps:

- Not currently used

Oil Cooling

The section defines how the Vission 20/20 will monitor and/or control the temperature of the compressor oil, see Figure 19-2. Configuration Screen - Page 2.

Thermosyphon:

- This defines the compressor oil cooling method as thermosyphon.

H2O Oil Cooler:

- This defines the compressor oil cooling method as water heat exchange.

Liquid Injection:

- This defines the compressor oil cooling method as liquid refrigerant injection.

Solenoids:

- Enables the solenoid for liquid injection control.

Motorized Valve:

- Enables the motorized valve for liquid injection controlled by PID settings.

Motor Current Device

The Vission 20/20 can read the motor current in a couple of different ways. The following selections defines the method, see Figure 19-2. Configuration Screen - Page 2.

Current Transformer:

- This defines the input used for motor current when a current transformer is used.

4-20ma Transformer:

- This defines the input used for motor current.

Section 19 • Configuration

Digital Inputs

The Vission 20/20 has several digital inputs that the operator can choose how the input will be used. Once an input is enabled, the Auxiliary I/O screen will be available from the menu screen where the operator can further define the inputs operation, see Figure 19-3. Configuration Screen - Page 3.

Enable Input #:

- Enables the selected digital input.

Set Name:

- Allows the operator to assign a name to the input.

Digital Auxiliaries

Digital Inputs

<input checked="" type="checkbox"/> Enable Input #1	Set Name <input type="text" value="Motor High Temp"/>	<input type="checkbox"/> Enable Input #5	Set Name <input type="text" value="Digital Aux in 5"/>
<input type="checkbox"/> Enable Input #2	Set Name <input type="text" value="Digital Aux in 2"/>	<input type="checkbox"/> Enable Input #6	Set Name <input type="text" value="Digital Aux in 6"/>
<input type="checkbox"/> Enable Input #3	Set Name <input type="text" value="Digital Aux in 3"/>	<input type="checkbox"/> Enable Input #7	Set Name <input type="text" value="Digital Aux in 7"/>
<input type="checkbox"/> Enable Input #4	Set Name <input type="text" value="Digital Aux in 4"/>	<input type="checkbox"/> Enable Input #8	Set Name <input type="text" value="Digital Aux in 8"/>

Page 1 2 3 4 5 6 Apply Close

Figure 19-3. Configuration Screen - Page 3

Section 19 • Configuration

Analog Inputs

The Vission 20/20 has several Analog inputs that the operator can choose how the input will be used. Once an input is enabled, the Auxiliary I/O screen will be available from the menu screen where the operator can further define the inputs operation, see Figure 19-4. Configuration Screen - Page 4.

Enable Input #:

- Enables the selected analog input.

Set Name:

- Allows the operator to assign a name to the input.

Enable Input #	Set Name	Enable Input #	Set Name
<input checked="" type="checkbox"/> Enable Input #1	Chiller Low Temp	<input type="checkbox"/> Enable Input #9	Analog Aux in 9
<input type="checkbox"/> Enable Input #2	Analog Aux in 2	<input type="checkbox"/> Enable Input #10	Analog Aux in 10
<input type="checkbox"/> Enable Input #3	Analog Aux in 3	<input type="checkbox"/> Enable Input #11	Analog Aux in 11
<input type="checkbox"/> Enable Input #4	Analog Aux in 4	<input type="checkbox"/> Enable Input #12	Analog Aux in 12
<input type="checkbox"/> Enable Input #5	Analog Aux in 5	<input type="checkbox"/> Enable Input #13	Analog Aux in 13
<input type="checkbox"/> Enable Input #6	Analog Aux in 6	<input type="checkbox"/> Enable Input #14	Analog Aux in 14
<input type="checkbox"/> Enable Input #7	Analog Aux in 7	<input type="checkbox"/> Enable Input #15	Analog Aux in 15
<input type="checkbox"/> Enable Input #8	Analog Aux in 8	<input type="checkbox"/> Enable Input #16	Analog Aux in 16

Page 1 2 3 4 5 6 Apply Close

Figure 19-4. Configuration Screen - Page 4

Section 19 • Configuration

Analog Outputs

The Vission 20/20 has several Analog outputs that the operator can choose how the outputs will be used. Once an output is enabled, the Auxiliary I/O screen will be available from the menu screen where the operator can further define the outputs operation, see Figure 19-5. Configuration Screen - Page 5.

Enable Output #:

- Enables the selected analog output.

Set Name:

- Allows the operator to assign a name to the output.

Digital Outputs

The Vission 20/20 has several Digital outputs that the operator can choose how the output will be used. Once an output is enabled, the Auxiliary I/O screen will be available from the menu screen where the operator can further define the outputs operation, see Figure 19-5. Configuration Screen - Page 5.

Enable Output #:

- Enables the selected digital output.

Set Name:

- Allows the operator to assign a name to the output

Auxiliary Outputs

Analog Outputs

<input type="checkbox"/> Enable Output #1	Set Name <input type="text" value="Analog Aux out 1"/>	<input type="checkbox"/> Enable Output #3	Set Name <input type="text" value="Analog Aux out 3"/>
<input type="checkbox"/> Enable Output #2	Set Name <input type="text" value="Analog Aux out 2"/>	<input type="checkbox"/> Enable Output #4	Set Name <input type="text" value="Analog Aux out 4"/>

Digital Outputs

<input type="checkbox"/> Enable Output #1	Set Name <input type="text" value="Digital Aux out 1"/>	<input type="checkbox"/> Enable Output #3	Set Name <input type="text" value="Digital Aux out 3"/>
<input type="checkbox"/> Enable Output #2	Set Name <input type="text" value="Digital Aux out 2"/>	<input type="checkbox"/> Enable Output #4	Set Name <input type="text" value="Digital Aux out 4"/>

Page 1 2 3 4 5 6 Apply Close

Figure 19-5. Configuration Screen - Page 5

Section 19 • Configuration

I/O Configuration

If any additional I/O card are added to Vission 20/20, this is where these cards are enabled for use by the Vission 20/20 algorithms. Some feature of the Vission 20/20 will not be available unless specific expansions cards are selected, see Figure 19-6. Configuration Screen - Page 6.

Digital Output 1:

- Not editable by the operator. Identifies that the Digital Output card 1 is enabled.

Digital Output 2:

- Not editable by the operator. Identifies that the Digital Output card 2 is enabled.

Digital Input 1:

- Not editable by the operator. Identifies that the Digital Input card 1 is enabled.

Digital Input/Output 1:

- Enables the optional digital input/output card 1

Digital Input/Output 2:

- Enables the optional digital input/output card 2

Analog Input 1:

- Not editable by the operator. Identifies that the Analog Input card 1 is enabled.

Analog Input 2:

- Not editable by the operator. Identifies that the Analog Input card 2 is enabled.

Analog Input 3:

- Enables the optional Analog input card 3.

Analog Input 4:

- Enables the optional Analog input card 4.

Analog Output:

- Enables the optional Analog Output card.

I/O Configuration

Digital Output 1

OPEN			
O	O	O	
			X
4	3	2	1

Digital Output 2

OPEN			
O	O		O
		X	
4	3	2	1

Digital Input 1

OPEN			
O	O		
		X	X
4	3	2	1

Digital Input/Output 1

OPEN			
O		O	O
	X		
4	3	2	1

Digital Input/Output 2

OPEN			
O		O	
	X		X
4	3	2	1

Analog Input 1

OPEN			
O			O
	X	X	
4	3	2	1

Analog Input 2

OPEN			
O			
	X	X	X
4	3	2	1

Analog Input 3

OPEN			
	O	O	O
X			
4	3	2	1

Analog Input 4

OPEN			
	O	O	
X			X
4	3	2	1

Analog Output

OPEN			
	O		O
X		X	
4	3	2	1

Page 1 2 3 4 5 6 Apply Close

Figure 19-6. Configuration Screen - Page 6

Section 20 • Data Backup

Overview

The database backup screen provides the operator a way to extract information out of the Vission 20/20 for backup purposes or diagnostics, see Figure 20-1 Data Backup Screen. Through this screen, the operator can download all the Setpoint Databases, Maintenance Logs, Event Lists, Freeze Data, Trend Data and Compressor Run Hours to a portable USB flash drive. That information can then be uploaded back to the Vission 20/20 in the case of data corruption or to update the Vission program. Built in migrate function examines the previous setpoint databases, compares it with newer program setpoint database, and moves the old information into the new program. In addition, this screen also allows the operator to reset all values to the factory defaults.

All of the information saved to the USB flash drive is open information. Meaning none of the information is encrypted and the operator is free to examine it. The log files are all saved as simple ASCII text and the databases can be examined with SQLite.

Refresh:

- The Refresh button is used to initiate a scan of the USB ports and list any devices found in the “Available Devices” window.

Save / Load

Save / Load section is where the operator can either save the Vission 20/20 setpoints and log information to a USB flash drive or load from a USB flash drive back to the Vission 20/20.

Save:

- Selecting save allows the operator to save the Vission 20/20 data to a USB flash drive using the information provided further down the screen. The bottom button will be labeled “Save” when this is selected.

Suction Pressure 1 Stopped 12.4 Psig Δ

Save / Load

Save Load

Available Devices: /media/usb0

Select Folder/File: db08062013.zip, 123.zip

Filename: /media/usb0/

Settings: All Select

Compressor Control Alarms & Trips Timers Maintenance

Compressor Sequencing Compressor Scheduling Condenser Control Users

Calibration Configuration Auxiliary I/O Trend Chart

Data Items: Run Hours Maintenance Logs Event List Freeze Data Trend Data

Buttons: Unmount, Back, Save, Refresh, Menu

Capacity Slide: 0.0% Stop

Volume Slide: 2.8% Alarm Reset Unit Start

Suction Press Control: Setpoint 20.0 Psig

Suction: Press 32.4 Psig Temp 48.6 °F

Discharge: Press 100.2 Psig Temp 122.9 °F

Oil: Press Diff 128.3 Psig Filter Diff 8.8 Psig Inj Temp 99.1 °F Sep Temp 115.8 °F

Motor: Amperage 0.0 Amps

Maintenance User Access Log off Help

No Scheduled Maintenance User Vilter

No Alarm/Trips Present 01/02/2002 12:53:20

Run Hours 0

Figure 20-1. Data Backup Screen - Save/Load

Section 20 • Data Backup

Load:

- Selecting load allows the operator to load data from a USB flash drive to the Vission 20/20 using the information provided further down the screen. The bottom button will be labeled “Load” when this is selected.

Available Devices:

- This window displays any USB flash drive plugged into one of the Vission 20/20 USB ports. Once one of the available devices is selected, then the drives contents will be displayed in the “Select Folder / File” window. If the USB flash drive that is plugged in by the operator is not showing up, then the operator can try pressing the “Refresh” button at the bottom of the screen. Unfortunately, not all USB flash drives are compatible with the Vission 20/20 and will never show up as available device.

Select Folder/File:

- This window displays the folders and files contained in the USB flash drive selected in the “Available Devices” window. The information from the Vission 20/20 will be contained into a .zip file. So a zip file will have to be selected to load or overwritten when saved. Once a zip files is selected, the name will be shown in the filename window.

Unmount:

- By pressing the Unmount button, any USB drive selected in the “Available Devices” window will be disconnected from the operating system and can be safely removed from the USB port.

Back:

- The back button returns the operator to the preceding window display of files and folders.

Filename:

- This window is where the operator can give a name to a saved backup file. This field will automatically be populated if a file is selected in the “Select Folder/ File” window.

Settings:

- Using this table, the operator can choose to save or load all or part of the information contained in the Vission 20/20.

Data Items:

- Using this table, the operator can choose to save or load all or part of the information contained in the Vission 20/20 according to checkbox selections.

Save / Load Button:

- This button initiates the save or load process.

Section 20 • Data Backup

Migrate:

Loading data from an older version of the Vission 20/20 software to a newer one can be complicated due to differences in databases. This migrate function closely examines each field in the database being loaded and determines whether it can be used in the new program. The Migrate function is executed automatically when a data is loaded from a USB flash drive. The only time an operator should have to use the following migrate button is if a new Vission 20/20 program is loaded over an existing Flash card, see Figure 20-2. Data Backup Screen - Migrate and Factory Reset.

Migrate:

- This button initiates the migrate function.

Factory Reset:

The Factory reset button offers the operator the ability to reset all the Vission 20/20 setpoints back to the factory default settings or a specific database. If the operator finds that a screen will not load when selected, it is likely that the database associated with that screen has been corrupted. Unfortunately, data corruption is always a possibility in any system. So this function was designed to help the operator to regain control, see Figure 20-2. Data Backup Screen - Migrate and Factory Reset.

Reset:

- This button initiates the process to revert the Vission 20/20 back to the factory default settings.

The screenshot displays the 'Data Backup Screen - Migrate and Factory Reset' interface. At the top, it shows 'Suction Pressure 1', 'Stopped', and '12.4 Psig Δ'. The main area is divided into two sections: 'Migrate' and 'Factory Reset'. The 'Migrate' section includes a 'Migrate' button and instructions. The 'Factory Reset' section includes a 'Reset' button and a 'Settings' list with checkboxes for various system components. On the right side, there are control panels for 'Capacity Slide' (0.0%), 'Volume Slide' (2.8%), and 'Suction Press Control' (Setpoint 20.0 Psig). Below these are readouts for 'Suction' (Press 32.4 Psig, Temp 48.4 °F) and 'Discharge' (Press 100.3 Psig, Temp 123.6 °F). At the bottom, there are status indicators for 'No Scheduled Maintenance' and 'No Alarm/Trips Present', along with user and system information like 'User: Vilter', 'Run Hours: 0', and 'Motor Amperage: 0.0 Amps'.

Figure 20-2. Data Backup Screen - Migrate and Factory Reset

Section 21 • Maintenance

Overview

The maintenance screen is a convenient place to keep track of the the maintenance performed and any upcoming maintenance recommended by Vilter. Based on this page, banners will be displayed on the lower status bar. Yellow banners are to warn the operator of any upcoming maintenance and red banners indicate maintenance that is overdue, see Figure 20-1. Maintenance Screen.

Checklist

The check list is where the operator will perform the maintenance sign-off. Once the operator has selected the item to sign off, pressing the “Update” button at the bottom of the page will perform the sign-off operation and list the maintenance performed in the maintenance log.

Maintenance Name:

- This column of tasks that should be performed at the run hours indicated in Maintenance interval column. Select the checkbox from the maintenance task name and press “update” button to perform the sign-off.

Maintenance Interval (Hours):

- This column indicates the Run hours at which the task in the first column should be performed. When a task is selected, the maintenance interval will change to reflect the next interval.

Time Remaining (Hours):

- This column indicates the Run hours left before the maintenance task should be performed.

The screenshot displays the Maintenance Screen interface. At the top, it shows 'Suction Pressure 1' as 'Stopped' at '35.9 Psig Δ'. The main area features a checklist table with columns for task name, Maintenance Interval (Hours), and Time Remaining (Hours). To the right of the table are control panels for Capacity Slide (2.2%), Volume Slide (2.7%), Suction Press Control (Setpoint 20.0 Psig), Discharge (Press 67.9 Psig, Temp 138.4 °F), Oil (Press Diff 11.4 Psig, Filter Diff 0.8 Psig, Inj Temp 116.9 °F, Sep Temp 111.9 °F), and Motor (Amperage 0.0 Amps). The bottom status bar shows 'No Scheduled Maintenance', 'No Alarm/Trips Present', and user information: User admin, 08/19/2011 04:27:20, Run Hours 31.

Checklist	Maintenance Interval (Hours)	Time Remaining (Hours)
<input type="checkbox"/> Oil Change	5000	4969
<input type="checkbox"/> Oil Analysis	5000	4969
<input type="checkbox"/> Oil Filters	200	169
<input type="checkbox"/> Oil Strainer	200	169
<input type="checkbox"/> Coalescing Elements	30000	29969
<input type="checkbox"/> Suction Screen	200	169
<input type="checkbox"/> Liquid Line Strainers	200	169
<input type="checkbox"/> Coupling Alignment	200	169
<input type="checkbox"/> Transducer Calibration	200	169
<input type="checkbox"/> RTD Calibration	200	169
<input type="checkbox"/> Inspect Compressor	5000	4969
<input type="checkbox"/> Inspect Bearings	120000	119969

Figure 21-1. Maintenance Screen

Section 21 • Maintenance

Notes

The notes tab allows the operator to make notes to any other personnel that might have access to the Vission 20/20.

Log

The maintenance log tab lists all the maintenance tasks performed in descending order.

Date:

- Lists the date the maintenance task was performed.

Time:

- Lists the time the maintenance task was performed.

User:

- Lists the operator name who performed the maintenance task.

Maintenance Performed:

- Lists the maintenance task that was performed.

Run Hours:

- Lists the run hours at which the maintenance task was performed.

Chart

This chart is the original maintenance chart that is provided with the compressor.

Section 22 • User Access

Overview

The user access screen is where all operators go to log in. In the Vission 20/20, each screen has a security level, whereby allowing operators, technicians and/or supervisors the ability to modify different sets of setpoints. The Vission 20/20 has four levels of security, see Figure 22-1. User Access Screen - Login.

- Level 0 – This is the default level with no operator logged in. The function available to the operator are very limited and basically only allows someone to start and stop the compressor.
- Level 1 – This is a technician level of access. All the setpoints needed to operate and adjust the performance of the compressor will be available to an operator with this level of access.
- Level 2 – This is a supervisor level of access. Setpoints that require a higher level of knowledge such as

calibrating instrument will be available to an operator with this level of access.

- Level 3 – This is considered a contractor level of access. The setpoints available at this level have the most potential of causing damage to the compressor. Therefore, this access is restricted to those only with the highest level of competence.

The user access screen is also where new operators are added, changed or removed. Any operator can add an additional operator but can only add an operator of lesser or equal security level.

Apply

When selected, applies the user name and password for security evaluation. If the User name and password matches an existing user then the operators name will be applied to the lower status bar and the operator will be given access to screens of equal security level.

Figure 22-1. User Access Screen - Login

Section 22 • User Access

Login

The login tab is where an operator will enter the users name and password in order to gain access to Vission 20/20 screens.

Operators:

- All operators that have been added to the Vission 20/20 user tables will be displayed in this window. If a name of an operator is selected from this window, the name is added to the “Operator Name” entry box.

Operator Name:

- This entry box is for the operator’s username. The operator can either select the username from the operators window or enter the username manually by touching the entry box and entering the name via the pop-up keyboard.

Operator Password:

- This entry box is for the operator’s password. The

password can be entered by touching the password entry box and entering the password via the pop-up keyboard.

Manage Accounts

This tab allows the addition, removal, and modification of authorized users, see Figure 22-2. User Access Screen - Manage Accounts.

Operators:

- This window contains the list of authorized users already added to the Vission 20/20. Selecting a name from this list will add that name to the “Operator Name” entry box.

Operator Name:

- This entry box is for the operator’s username who is to be added, removed or modified. The operator can

The screenshot displays the 'Manage Accounts' interface. At the top, system status is shown: 'Suction Pressure 1' is 'Stopped' at '6.9 Psig Δ'. The 'Manage Accounts' window is open, showing a list of operators with 'josh' selected. The 'Operator Name' field contains 'josh'. The 'Operator Password' and 'Verify Password' fields are masked with dots. The 'Security Level' is set to '3'. There are 'Add/Update' and 'Delete' buttons. The background interface includes a 'Capacity Slide' (0.0%), 'Volume Slide' (0.0%), 'Suction Press Control' (Setpoint 20.0 Psig, Press 26.9 Psig, Temp 33.1 °F), 'Discharge' (Press 165.1 Psig, Temp 134.8 °F), 'Oil' (Press Diff 146.4 Psig, Filter Diff 4.1 Psig, Inj Temp 131.1 °F, Sep Temp 123.6 °F), and 'Motor' (Amperage 0.0 Amps). The bottom status bar shows 'No Scheduled Maintenance', 'No Alarm/Trips Present', the date '03/02/2010 05:49:04', and 'Run Hours 0'.

Figure 22-2. User Access Screen - Manage Accounts

Section 22 • User Access

either select the username from the operators window or enter the username manually by touching the entry box and entering the name via the pop-up keyboard.

Operator Password:

- This entry box is for the operator's password. The password can be entered by touching the password entry box and entering the password via the pop-up keyboard.

Verify Password:

- This entry box is to verify the operator's password. Verifying the password can be entered by touching the "Verify Password" entry box and entering the password via the pop-up keyboard.

Security Level:

- Select a security level for the account being added or modified. Only levels that are equal to or less than the

operator's own security level will be shown.

Add / Update:

- Pressing this button will initiate the creation or modification of the specified account.

Delete:

- Pressing this button will delete the specified account.

Screen Security Levels

The following table lists all screen and their base security levels. The majority of the screens have more than one security level. The base security level gives the user access to the setpoints that can change to performance of the compressor. The secondary security level is typically level 3 and is reserved for those setpoints that require great care and knowledge of the system in order to change safely.

Table 22-1. Security Access Levels

Security Access Levels		
Page	User Level	* Note
Event List	Level 0	-
Input/Output States	Level 0	-
Trend Chart	Level 0	-
Help	Level 0	-
Alarms & Trips	Level 1 *	Level 3 required for constraints
Compressor Scheduling	Level 1	-
Compressor Sequencing	Level 1	-
Condenser Control	Level 1 *	Level 3 required for constraints
Compressor Control	Level 1 *	Level 3 required for constraints
Maintenance	Level 1	-
Data Backup	Level 1 *	Level 3 required to upload data
Instrument Calibration	Level 2	-
Service Option	Level 2	-
Configuration	Level 2 *	Level 3 required for pages 3 - 6
Slide Calibration	Level 2	-
Timers	Level 2 *	Level 3 required for constraints

Section 23 • Help Screen

Overview

Use this screen to receive help on other setpoint screens contained within the software. These help files can be accessed from any screen. The help files describe the functionality of that screen as well as compressor operation, see Figure 23-1. Help Screen.

Screen Features:

Manual Tab:

- Contains the list of available manual sections to be displayed in the display window.

USB tab:

- The operator as the option to view other manuals, typically Vilter compressor manuals on the Vission 20/20 from a USB drive. If there are any PDF type documents on a connected USB drive, the names

will be listed in this section. The operator will have to navigate through the file structure of the USB drive to find the documents. The top box in the USB drive will display any USB drives mounted to the Vission 20/20 OS.

- Touching one of the listed USB devices will select that device and list any files or PDF documents contained on the USB drive. Selecting a folder will open that folder and display any sub-folders of PDF documents.

Unmount:

- Pressing the unmount button will disconnect the USB drive from the Vission 20/20 operating system. Once the device has been remove from the device list, the USB drive can be safely removed

Refresh:

- Pressing this button will reread the USB ports and display any new USB drives.

The screenshot shows the 'Section 6 - Compressor Control' help screen. It features a 'Manual' tab with a list of sections on the left, a central text area with an overview and technical data, and a right-hand panel with control slides and status indicators.

Section 6 - Compressor Control

Overview:
The compressor control screen is where an operator can set the majority of the compressor settings. These setting define how the compressor will operate and respond to changing loads. The compressor control screen consists of several screens but in order not to overwhelm operator with options, many of the screens may not be visible. How the compressor is configured in the configuration screen will determine what screens are displayed. It is important to note that there isn't one correct way to set these parameters. Every application is different and requires the operator to tune these setting to achieve the best operation.

Pulse Proportional Control:

Suction Press Control	
Setpoint	20.0 Psig
Suction	
Press	21.6 Psig
Temp	101.2 °F
Discharge	
Press	72.2 Psig
Temp	128.8 °F
Oil	
Press Diff	75.7 Psig
Filter Diff	4.6 Psig
Inj Temp	103.7 °F
Sep Temp	139.8 °F
Motor	
Amperage	0.0 Amps

Additional screen elements include: 'Capacity Slide' (0.0%), 'Volume Slide' (4.3%), 'Stop' button, 'Remote Lock Out', 'Alarm Reset', 'Unit Start', 'Full Screen', 'Page 1', 'Previous', 'Next', 'Version', 'OK', 'Maintenance', 'User Access', 'Log off', 'Help', 'No Scheduled Maintenance', 'No Alarm/Trips Present', 'User: Vilter', '05/16/2012 06:00:47', 'Run Hours: 0'.

Figure 23-1. Help Screen

Section 23 • Help Screen

Back:

- Pressing the back button will rewrite the file/folder list with the previous folder level.

Display Window:

- This window displays the context of the manual.

Fullscreen:

- Pressing this button expand the display window to fit the entire screen.

Page:

- Enter the page number the operator wishes to be displayed in the display window.

Previous:

- Changes the page in the display window one page less than what was showing.

Next:

- Changes the page in the display window one page more than what was showing.

Version:

- Pressing the Version button displays a pop-up screen that gives the operator information of the version of software running on the Vission 20/20, see Figure 23-2. Version Pop-Up Screen.

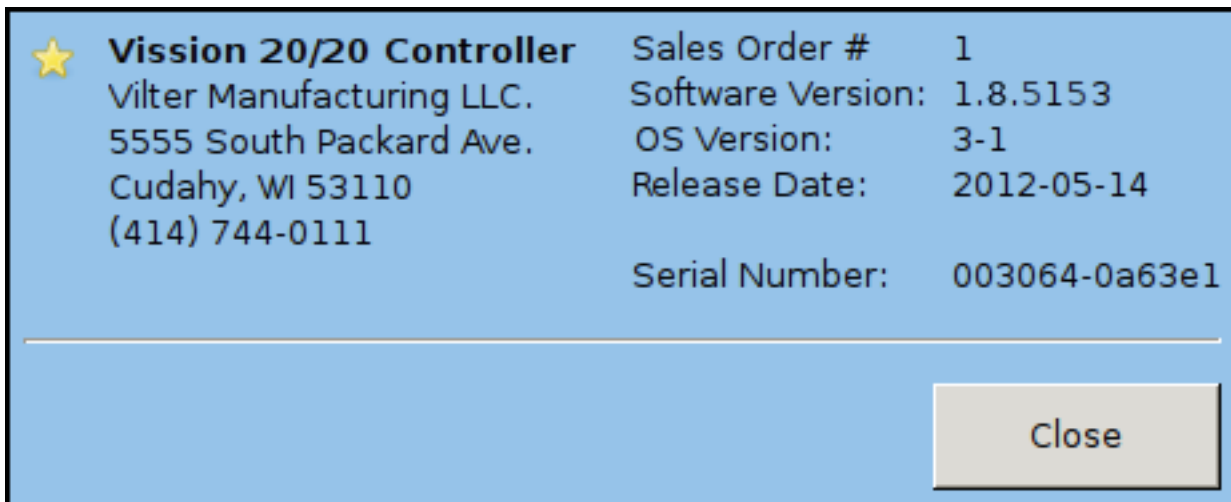

Figure 23-2. Version Pop-Up Screen

Section 24 • Twin Screw Control

Overview

The Vission 20/20 is capable of operating a twin screw compressor from a number of different manufacturers. The Vission 20/20 currently operates as a twin screw controller in the full time oil pump and the no oil pump configuration, see Figure 24-1. Twin Screw Control Screen.

Setup

Configuration Screen:

- To setup the Vission 20/20 panel for twin screw, navigate to the configuration screen, page 2, and select “VRS” from the dropdown box label “Compressor”. Once selected, another dropdown box labeled “Operation Type” will appear directly below the “Compressor” drop-down box. You should also notice that the oil pump control becomes grayed out

because the oil pump operation is now determined by the type of compressor that is select from the “Type” drop-down box.

- Standard - Selects the oil pump operation as “Full Time”.
 - Stal - Selects the oil pump control as “No pump”.
- Menu Changes:
 - When selecting the twin screw option there will be other changes that occur in other menu pages.
 - Volume position indicator will disappear from the main screen and right data panel.
 - Prelube oil pump alarms and trip values will be changed to default values for the twin screw
 - Run oil pump alarm and trip values will be changed to default values for the twin screw.

Figure 24-1. Twin Screw Control Screen

Section 24 • Twin Screw Control

Operation

Once the twin screw is configured, its operation is very similar as the single screw and all options that are available for single screw configuration are also available for twin screw. The only operational difference is the manual mode of operation. Twin screw compressors can experience leaky slide seals that can cause the capacity slide to drift after it has been positioned by the controller. To counteract the capacity slide drift problem, the twin screw manual mode operation has an added anti-drift feature that automatically maintains the position of the hydraulic actuator.

Section 25 • Cool Compression Control

Overview

The cool compression compressor operation is similar to the standard single screw compressor units, except there is no external oil cooler to the unit. A blanket of liquid ammonia lies on top of the oil in the oil separator. The liquid ammonia level is regulated by sensing the liquid ammonia level with a level probe, and using a positioning valve to vary the amount of liquid ammonia being added to the separator. The cooling occurs through the entire compression and separation process. The Cool Compression compressor does not have an oil pump. When the Cool Compression compressor unit is commanded to start, the control panel first insures that the slide valves are at their minimum positions. The suction oil injection solenoid (SOI) is energized – allowing a path for oil to flow into the compressor. The compressor now starts. There is an initial pressure drop in the suction chamber of the compressor and a corresponding increase in pressure on the discharge of the compressor. This creates a pressure differential that forces the oil and liquid ammonia mixture through the suction oil

injection line into the suction chamber of the compressor. This oil and liquid provides lubrication and cooling until full pressure differential lubrication is attained. As the differential pressure increases, the oil and liquid ammonia is now injected into the screw during the compression process and the oil injection valve is allowed to close.

Setup

Configuration Screen:

- To setup the Vission 20/20 panel for Cool Compression, first ensure that an analog output card is installed in the panel, and it is selected/enabled from page 6 of the configuration screen, see Figure 25-1. Cool Compression Control Screen. Navigate to configuration page 2, and select “R717-Cool Comp” from the drop-down box that is labeled “Refrigerant”. Once selected “Cool Compression” option will appear in Oil Pump and Oil Cooling sections and “Cool Compression” gets selected automatically. It will also

Compressor: VSS
Model: 451
Refrigerant: R717 - Cool Comp
Other (K-Factor): 1

Compressor Control # Controllers

Suction Pressure Control 2
 Process Temp. Control 1

Optional Function Selection

Compressor VFD
 % Slide Volume Position
 Economizer Pressure
 Superheat Monitor

Condenser Control

Ambient Sensor
 Wetbulb Sensor
 VFD Fan

Oil Pump

No Pump
 Cycling
 Full Time
 Cool Compression

Pumps: 1

Oil Cooling

Thermosyphon
 H2O Oil Cooler
 Liquid Injection
 Solenoids 1
 Motorized Valve
 Cool Compression

Motor Current Device

Current Transformer
 4-20ma Transmitter

Page: 1 2 3 4 5 6 Apply Close

Figure 25-1. Cool Compression Control Screen

Section 25 • Cool Compression Control

enable Superheat Monitoring on the screen.

- As previously described, Cool Compression compressor does not have an oil pump. Instead it has a suction oil injection solenoid to provide oil and liquid ammonia for lubrication and cooling.
- Cool Compression liquid injection 1 and liquid injection 2 outputs will operate as high / low pressure ratio solenoid outputs.

Control Functions

In the Compressor Control Menu, special cool compression control functions are now available, see Figure 25-2. Cool Compression Control Functions Screen. These new functions are:

- Auto Load

- Suction Oil Injection Settings
- Danfoss Positioning Valve Settings

Auto Load

- Auto load operation will force the compressor to load to a minimum value once the compressor has started. By loading the compressor to a minimum value, and maintaining this capacity, a pressure ratio is created across the compressor, to ensure adequate lubrication of the compressor, and also that the compressor does not experience high discharge superheat conditions. Since compressor lubrication is of great importance, all load limiting is disabled when auto load is engaged.
- Auto Load at Start
 - Defines the value at which Compressor (capacity slide) should be loaded (and maintained) at start if Auto Load is enabled.

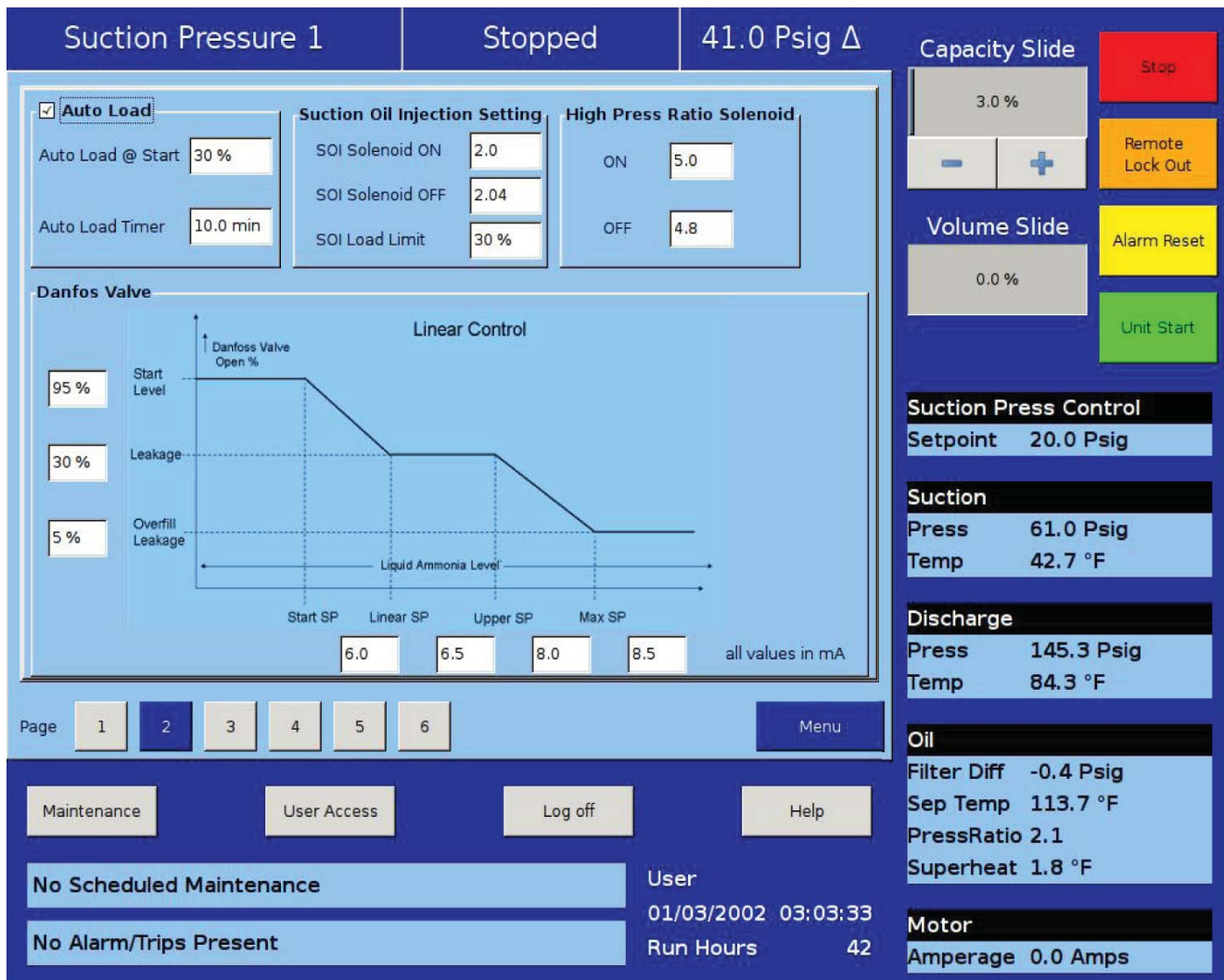

Figure 25-2. Cool Compression Control Functions Screen

Section 25 • Cool Compression Control

- Auto Load Timer
 - This timer defines the maximum time that the Auto Load operation will be engaged. After the timer expires, Auto Load will be disengaged.
- Auto load will be disengaged when one of the following conditions occur;
 - Pressure ratio reaches a value of 2.0 or greater.
 - Compressor has been running for 10 minutes (defined by Auto Load Timer).
 - Suction pressure setpoint has been reached.

Suction Oil Injection Setting

- In order to maintain adequate lubrication during low pressure ratio conditions, the Suction Oil Injection (SOI) solenoid is turned ON and the capacity of the compressor is reduced.
- The SOI solenoid will cycle ON and OFF based on the pressure ratio across the compressor.
- SOI Solenoid ON
 - Defines the Pressure ratio value at which SOI is turned ON (default 2.00) (Digital Output Board #1:2).
- SOI Solenoid OFF
 - Defines the Pressure ratio value at which SOI is turned OFF (default 2.04) (Digital Output Board #1:2).
- SOI Load Limit
 - Defines the capacity slide position at which the compressor capacity slide will unload to if pressure ratio falls below “SOI Solenoid ON” setpoint. This setpoint is not active until Auto Load disengages.
- The SOI solenoid will also cycle on if the discharge temperature superheat reaches a value of 5°F (this value is not settable). Generally, anytime the SOI solenoid cycles on, the capacity is limited to the SOI Load Limit setpoint. However, this is not true if the SOI solenoid cycles on based on the discharge temperature superheat 5°F rule. If discharge temperature superheat continues to climb and reaches a value of 6°F, the compressor will be inhibited from loading. If discharge temperature superheat still continues to climb and reaches a value of 8°F or more, then the compressor will be unloaded until the superheat drops below 8°F or the capacity has reached the SOI Load Limit setting.

Using a Positioning Valve for Liquid Ammonia Level Control

- A level probe inserted in the oil separator detects liquid ammonia level. Based on the level of the ammonia (0-100%), the level probe sends a directly proportional 4-20 mA signal to the Vission 20/20 panel. The positioning valve is then positioned based on the Positioning Valve settings graph shown in Figure 25-2. Cool Compression Control Functions Screen.
- Looking at the graph, when the compressor starts, the positioning valve placement (Vertical Axis) is determined based on the liquid ammonia level that is sensed in the oil separator (Horizontal Axis). It can be seen that as the liquid ammonia level increases (corresponding to a larger mA value), the positioning valve moves towards a closed position.
- The Positioning Valve position (0-100% limits) is defined at three distinct levels;
 - Start Level (lowest liquid ammonia level - positioning valve at maximum open position).
 - Leakage (normal operating position and ammonia level).
 - Overfill Leakage (highest liquid ammonia level—positioning valve at minimum open position).
- Liquid ammonia levels are defined at four distinct levels (4-20ma limits);
 - Start SP (minimum liquid ammonia level in separator – the positioning valve is maximum open).
 - Linear SP (minimum level of liquid ammonia for normal operating position).
 - Upper SP (maximum level of liquid ammonia for normal operating position).
 - Max SP (maximum liquid ammonia level – positioning valve is minimum open position, maintaining some leakage).
- On Alarms and Trips screen, Low Oil Separator Start Temperature, High Filter Diff Start Pressure settings are disabled.
- On Timers screen Oil Level #1 Safety Trip Delay, Oil Level #2 Safety Trip Delay settings are disabled.

Operational Differences from Single Screw

Once the Cool Compression is configured, most setup options available for a single screw are also available for Cool Compression. However, there are significant

Section 25 • Cool Compression Control

operational differences that are mostly associated with the compressor safeties:

1. The Cool Compression program ignores,
 - Low Oil Separator Alarm / Trip at start
 - High Filter Differential at start
 - Prelube Oil Pressure Alarm and Trip
 - Run Oil Pressure Alarm and Trip (Pressure Ratios are monitored instead).
 - High Discharge Temp Alarm and Trip (Discharge Temp Superheat is monitored)
 - Low Suction Temp Alarm and Trip
 - Low Oil Injection Temp Alarm and Trip
 - High Oil Injection Temp Alarm and Trip
2. SOI solenoid is forced on for first 60 seconds of running and 10 minutes after compressor is stopped.
3. Auto Load Enabled: When Auto Load is engaged at start, it then maintains the position of capacity slide to the Auto Load limit (approx : 30 %, but less than 50 %). It displays status message “Cool Compression Capacity Hold” when it is running. Unless Auto load is disengaged compressor will run at auto load limit position. Auto load disengages if enough Pressure Ratio is built (typically more than 2.04) or setpoints are achieved.
4. SOI Solenoid: During normal operation if pressure ratio drops to a lower value (typically below 2.00) then it energizes SOI solenoid and maintains the position of capacity slide to the SOI Load limit (approx : 30 %, less than 50 %). It also displays status message “Cool Compression Capacity Hold”. If enough Pressure Ratio is built across the compressor (typically more than 2.04), it again resumes the run mode and control normally.
5. It performs Cool Compression specific checks periodically like:
 - Controlling the liquid level positioning valve as liquid ammonia level changes .
 - Low / high Pressure Oil Injection ports control as Pressure Ratio and Superheat temperature changes.

Supplemental Oil Cooling Solenoids

- Some cool compression units will have supplemental oil cooling solenoids. One is called the suction liquid injection solenoid and is controlled via discharge superheat. When the discharge superheat reaches 5°F, the solenoid is turned on. When it falls back to below 4°F, the solenoid is turned off. An additional solenoid (referenced as SV4 – as called the High Press Ratio solenoid) provides supplemental oil cooling based on pressure ratio. When the pressure ratio rises above

5.0, the solenoid is turned on. When the pressure ratio falls back to below 4.8, the solenoid is turned off.

Level Switches

- There are two level switches in the oil separator, a “high” and a “low”. During normal running operation, the oil level is above both switches. When the oil level starts to drop and opens the high level switch, a 10 minute timer starts. When the timer elapses a flashing “add oil to middle of sight glass” message appears on the main screen. When the operator adds enough oil to close the high level switch, the message disappears.

NOTICE

If oil is not added and the oil level continues to drop thereby opening the “low” oil level switch, a 10 minute timer starts again. When the timer elapses, the compressor shutdowns immediately and displays “Low Oil Level” failure. If enough oil is added to close the low level switch, then this will allow the operator to press the reset button and clear the “Low Oil Level” failure and “Add Oil” message.

Oil Level Messaging After Compressor Stops

- The low level switch is monitored after the compressor stops. If the switch opens after the compressor stops, a two minute timer starts. If the switch stays open, and the timer expires, a failure is generated called “Lo Oil Level Fail after Stop” and the compressor is disabled from restarting until oil is added to close the low level switch. Note that this failure is generated ONLY when the low level switch opens after the compressor stops.

EmersonClimate.com