



Manufacturers of Industrial Refrigeration  
and Gas Compression Equipment

# Recip Vantage Micro-Controller Operating Manual

Ammonia (R717)

8/23/2007 8:38:38  
Runtime: 0:00:00  
Oil Heater: On

<b>Motor Amps</b> 0 amps	<b>Suction</b> 40 psig 50 F	<b>% CAP</b> 100%
<b>Discharge</b> 205 psig 120 F		
<b>Discharge #2</b> 205 psig 120 F		
<b>Oil Filter</b> In 205 Out 200 diff 5	<b>Oil Pressure Differential</b> 5 diff	<b>Crankcase Oil</b> 135

Unit Start

Alarm Reset

Stop

Menu

Setup



Maintenance

Version

Help



**Important Note:**

  	<p style="background-color: red; color: white; padding: 5px;"><b>⚠ DANGER</b></p> <p><b>Read and understand operator's manual before using/ servicing this machine.</b></p> <p><b>Failure to follow operating instructions could result in serious injury Possible Electrocution or burn.</b></p> <p><b>Follow lockout/tag out procedures before working inside this equipment.</b></p>
---	---

Before applying power to the VANTAGE MicroController panel, all wiring to the panel should be per NEC. Specifically check for proper voltage and that the neutral is grounded at the source. An equipment ground should also be run to the panel.

\*See Wiring Instructions and Diagrams before proceeding.

Before start-up you need to enter all system values and options, see section on Setpoint Values.

Before Powering the Vantage Control Panel down, it is suggested to perform a “Backup Settings” procedure to insure that all previously change setpoints have been properly saved.. After Backing Up the setpoints **DO NOT** power down the Vantage for at least 1 minute. This will allow adequate time for all setpoints to be properly saved.

*Note: The screen shots depicted in this manual represent the screens corresponding to Vantage program version # 2.4.24, the current version at time of printing. In our effort to continuously improve the functionality and ease-of-use of the Vantage Micro-controller, the look of some screens may differ slightly than the representations shown here.*

Equipment Identification Numbers:

Vilter Order Number: \_\_\_\_\_ Serial Number: \_\_\_\_\_  
 Vilter Order Number: \_\_\_\_\_ Serial Number: \_\_\_\_\_



## Table of Contents

<i>Important Note: Read Carefully</i> .....	3
DOMESTIC TERMS and CONDITIONS .....	6
EXPORT TERMS and CONDITIONS .....	8
STANDARD VILTER WARRANTY STATEMENT .....	10
VMC Compressor Operational Flowchart .....	10
Wiring Instructions For Vantage Only .....	12-19
Wiring Diagram For Vantage Only .....	18
Modbus Details .....	21
Main Screen .....	22
Set Up Screen .....	23
Log On, off or Save Changes .....	25
Version Screen .....	25
Maintenance Screen .....	26
Menu Screen .....	28
Common Buttons .....	29
Compressor Control .....	30
Compressor Alarm and Trip .....	34
Compressor Setpoints and Alarms .....	36
Compressor Timer Setpoints .....	37
Shut Down Data .....	39
Miscellaneous Screens .....	40
Instrument Calibration .....	44
Trend Chart .....	46
Data Select Screen .....	47
Event List .....	49



Trouble Shooting Flowchart Vantage Only .....	50
Safety Failure Message .....	52
Flash Card Installation Instructions .....	56
Back Light Installation Instructions .....	58
System Setpoints Alarms and Trip .....	61
Modifications for Analog Board in Vission/Vantage after July 2003 .....	70



## DOMESTIC TERMS and CONDITIONS

Exclusivity. Seller's acceptance of Buyer's order is expressly conditional upon Buyer's agreement to these terms and conditions. All inconsistent or additional terms, modifications, or changes are deemed material, are expressly rejected, and do not form a part of this Agreement unless Seller agrees to such terms in writing.

Home Office Approval. Buyer understands that no agent of Seller is authorized to execute this Agreement or bind Seller unless this Agreement and any purported change are signed by a home office Officer of Seller.

Prices and Payments. Prices are exclusive of taxes and may be modified at any time prior to Seller receiving Buyer's binding order. Upon acceptance, prices are firm for only three months and subject to reasonable escalation. Unless agreed otherwise in writing, all payments are due in full within 30 days of Seller shipping the products or providing the services. All overdue amounts will incur finance charge of the lesser of (a) 1 ½ % per month and (b) the maximum allowed by law.

Security Agreement. This Agreement shall be considered a security agreement to the maximum extent allowed by law. Seller shall have, retain, and possess a security interest in all products sold to Buyer until Seller is paid in full. Buyer grants to Seller a power of attorney to complete, sign on Buyer's behalf, and file all forms reasonably necessary to perfect Seller's security interest. If Buyer defaults, or Seller deems itself insecure of receiving payment, the full unpaid balance shall become immediately due and payable at the option of the Seller, and Seller may retake possession of the products without Court order.

Delivery. Seller shall not be liable for delivery delays beyond its control, including delays caused by its suppliers. All delivery dates and rates of production statements are merely good faith estimates. Unless otherwise stated on Seller's Order Acknowledgment, all shipments are F.O.B. Seller's factory. Seller reserves the rights to make installment deliveries.

Warranties. Seller warrants the products it manufactures to be free from defects in material and workmanship for a period of eighteen (18) months from the date of shipment from Seller's manufacturing plant or twelve (12) months from date of installation at the initial end users location, whichever occurs first. In addition, Seller provides the following extended warranties: (a) three (3) years from the date of shipment on single screw compressor internal rotating parts, (b) two (2) years from the date of shipment on reciprocating compressors and single screw and reciprocating compressor parts, and (c) two (2) years on all other parts on a single screw compressor unit. Such warranties do not apply to ordinary wear and tear. Seller does not warrant that the product complies with any particular law or regulation not explicitly set forth in the specifications, and Buyer is responsible for ensuring that the product contains all features necessary to safely perform in Buyer's and its customer's plants and operations. Buyer must notify Seller of any warranty claim within ten (10) days after such claim arises, otherwise Buyer waives all rights to such claim. Products supplied by Seller which are manufactured by others are not warranted by Seller, but rather Seller merely passes through the manufacturer's warranty to Buyer. **SELLER EXPRESSLY DISCLAIMS ALL OTHER WARRANTIES, WHETHER EXPRESS OR IMPLIED, INCLUDING THE IMPLIED WARRANTIES OF MERCHANTABILITY AND FITNESS FOR A PARTICULAR PURPOSE.** Unless otherwise agreed in writing, Buyer's sole remedy for breach of warranty is, at Seller's option, the repair of the defect, the correction of the service, or the providing a replacement part FOB Seller's office. Seller will not be responsible for costs of dismantling, lost refrigerant, reassembling, or transporting the product. Further, Seller will not be liable for any other direct, indirect, consequential, incidental, or special damages arising out of a breach of warranty. **THESE WARRANTY REMEDIES ARE EXCLUSIVE, AND ALL OTHER WARRANTY REMEDIES ARE EXCLUDED.** Products or parts for which a warranty claim is made are to be returned transportation prepaid to Seller's factory. Any improper use, corrosion, neglect, accident, operation beyond rated capacity, substitution of parts not approved by Seller, or any alteration or repair by others which, in Seller's judgment, adversely affects the Product, shall void all warranties and warranty obligations. Further, Seller shall not be liable under the above warranties should Buyer be in default of its payment obligations to Seller under this Agreement or any credit agreement.



## DOMESTIC TERMS and CONDITIONS

Changes, Cancellations, and Returns. Buyer will pay reasonable charges and all associated costs and damages arising from canceling or changing this Agreement. No returns shall be allowed other than with Seller's express permission, and such returns shall include a reasonable restocking charge to the extent permitted by law.

Resellers and Distributors. Should Buyer resell the product to a third party, then Buyer agrees to provide a copy of these Terms and Conditions to such third party prior to the sale, and obtain such third party's agreement to be bound by the relevant provisions including, but not limited to, the Warranties Section and the Limitation of Liability Section. Buyer agrees to indemnify Seller against any and all claims, damages, or liability (including reasonable attorney fees) arising from Buyer's breach of the obligations set forth in this Section.

Proprietary Rights. All designs and information provided by Seller remain its property, and Buyer shall honor all proprietary legends.

Limitation of Liability. The Seller's price is based on the enforceability of this limitation of liability, and the Buyer understands that the price would be substantially higher without this limitation. **SELLER SHALL HAVE NO LIABILITY TO BUYER FOR LOST PROFITS OR FOR SPECIAL, CONSEQUENTIAL, EXEMPLARY OR INCIDENTAL DAMAGES OF ANY KIND, WHETHER ARISING IN CONTRACT, TORT, PRODUCT LIABILITY OR OTHERWISE, EVEN IF ADVISED OF THE POTENTIAL DAMAGES IN ADVANCE.**

**IN NO EVENT SHALL SELLER BE LIABLE TO BUYER FOR ANY DAMAGES WHATSOEVER IN EXCESS OF THE CONTRACT PRICE. IN THE EVENT THAT ANY WARRANTY OR WARRANTY REMEDY FAILS OF ITS ESSENTIAL PURPOSE, OR IS HELD TO BE INVALID OR UNENFORCEABLE FOR ANY REASON, IN CONSIDERATION OF THE OTHER PROVISIONS OF THIS AGREEMENT, THE PARTIES AGREE THAT ALL LIABILITY LIMITATIONS WILL NEVERTHELESS REMAIN IN EFFECT.**

Governing Law. This Agreement shall be governed by the internal laws of the State of Wisconsin, without resort to conflicts of law analysis.

Attorney fees, Collection Costs, and Indemnification. Buyer agrees to defend and indemnify Seller against any claims, damages, or liability (including attorney fees) arising out of Buyer's violation of any law or breach of its obligations under this Agreement including, but not limited to, personal injury, death, or property damage. In addition, Buyer shall reimburse Seller all reasonable attorney fees and collection costs incurred by Seller to enforce its rights against Buyer under this Agreement.

Manuals and Brochures. Buyer shall communicate to Seller any special needs, pictorials, labels, warning signs, instructions, or language required for the manuals and brochures used for the products. Buyer agrees to pay a reasonable surcharge for additional manuals, special manuals, and brochures.

Severability. Any legally unenforceable provision may be severed from this Agreement, and the remaining terms and conditions will be enforced as a whole as if such provision had not been inserted herein.

Waiver, Entire Agreement. No waiver by either party of a right under this Agreement shall waive any other rights. These terms and conditions and any other writing signed by Seller constitute the entire agreement, and may not be modified other than in writing signed by Seller.



## EXPORT TERMS and CONDITIONS

Exclusivity. Seller's acceptance of Buyer's order is expressly conditional upon Buyer's agreement to these terms and conditions. All inconsistent or additional terms, modifications, or changes are deemed material, are expressly rejected, and do not form a part of this Agreement unless Seller agrees to such terms in writing.

Home Office Approval. Buyer understands that no agent of Seller is authorized to execute this Agreement or bind Seller unless this Agreement and any purported change are signed by a home office Officer of Seller.

Prices and Payments. Prices are exclusive of taxes and may be modified at any time prior to Seller receiving Buyer's binding order. Upon acceptance, prices are firm for only three months and subject to reasonable escalation. Unless agreed otherwise in writing, all payments are due in full upon receipt of order or Vilter's receipt of an acceptable letter of credit. All overdue amounts will incur finance charge of the lesser of (a) 1 ½ % per month and (b) the maximum allowed by law.

Export Transactions. If the products provided under this Agreement are to be shipped or used outside of the United States, then the following terms apply unless otherwise agreed by Seller in writing: (1) Buyer shall be responsible for all export and import scheduling and financial arrangements, (2) Buyer shall be responsible for compliance with all export and import laws and shall comply, and shall cause its agents to comply, with the Foreign Corrupt Practices Act, (3) the United Nations Convention on the International Sale of Goods shall not apply or govern the transaction, (4) Buyer accepts all responsibility for the products complying with any non-United States based laws, regulations, and other legal requirements, and (5) Seller shall be entitled to condition any shipment upon Buyer obtaining an acceptable Letter of Credit in Seller's favor confirmed at a United States based bank of Seller's choosing.

Delivery. Seller shall not be liable for delivery delays beyond its control, including delays caused by its suppliers. All delivery dates and rates of production statements are merely good faith estimates. Unless otherwise stated on Seller's Order Acknowledgment, all shipments are F.O.B. Seller's factory. Seller reserves the rights to make installment deliveries.

Warranties. Seller warrants the products it manufactures to be free from defects in material and workmanship for a period of eighteen (18) months from the date of shipment from Seller's manufacturing plant or twelve (12) months from date of installation at the initial end users location, whichever occurs first. In addition, Seller provides the following extended warranties: (a) three (3) years from the date of shipment on single screw compressor internal rotating parts, (b) two (2) years from the date of shipment on reciprocating compressors and single screw and reciprocating compressor parts, and (c) two (2) years on all other parts on a single screw compressor unit. Such warranties do not apply to ordinary wear and tear. Seller does not warrant that the product complies with any particular law or regulation not explicitly set forth in the specifications, and Buyer is responsible for ensuring that the product contains all features necessary to safely perform in Buyer's and its customer's plants and operations. Buyer must notify Seller of any warranty claim within ten (10) days after such claim arises, otherwise Buyer waives all rights to such claim. Products supplied by Seller which are manufactured by others are not warranted by Seller, but rather Seller merely passes through the manufacturer's warranty to Buyer. **SELLER EXPRESSLY DISCLAIMS ALL OTHER WARRANTIES, WHETHER EXPRESS OR IMPLIED, INCLUDING THE IMPLIED WARRANTIES OF MERCHANTABILITY AND FITNESS FOR A PARTICULAR PURPOSE.** Unless otherwise agreed in writing, Buyer's sole remedy for breach of warranty is, at Seller's option, the repair of the defect, the correction of the service, or the providing a replacement part FOB Seller's office. Seller will not be responsible for costs of dismantling, lost refrigerant, reassembling, or transporting the product. Further, Seller will not be liable for any other direct, indirect, consequential, incidental, or special damages arising out of a breach of warranty. **THESE WARRANTY REMEDIES ARE EXCLUSIVE, AND ALL OTHER WARRANTY REMEDIES ARE EXCLUDED.**





## EXPORT TERMS and CONDITIONS

Products or parts for which a warranty claim is made are to be returned transportation prepaid to Seller's factory. Any improper use, corrosion, neglect, accident, operation beyond rated capacity, substitution of parts not approved by Seller, or any alteration or repair by others which, in Seller's judgment, adversely affects the Product, shall void all warranties and warranty obligations. Further, Seller shall not be liable under the above warranties should Buyer be in default of its payment obligations to Seller under this Agreement or any credit agreement.

**Changes, Cancellations, and Returns.** Buyer will pay reasonable charges and all associated costs and damages arising from canceling or changing this Agreement. No returns shall be allowed other than with Seller's express permission, and such returns shall include a reasonable restocking charge to the extent permitted by law.

**Proprietary Rights.** All designs and information provided by Seller remain its property, and Buyer shall honor all proprietary legends.

**Limitation of Liability.** The Seller's price is based on the enforceability of this limitation of liability, and the Buyer understands that the price would be substantially higher without this limitation. **SELLER SHALL HAVE NO LIABILITY TO BUYER FOR LOST PROFITS OR FOR SPECIAL, CONSEQUENTIAL, EXEMPLARY OR INCIDENTAL DAMAGES OF ANY KIND, WHETHER ARISING IN CONTRACT, TORT, PRODUCT LIABILITY OR OTHERWISE, EVEN IF ADVISED OF THE POTENTIAL DAMAGES IN ADVANCE.**

**IN NO EVENT SHALL SELLER BE LIABLE TO BUYER FOR ANY DAMAGES WHATSOEVER IN EXCESS OF THE CONTRACT PRICE. IN THE EVENT THAT ANY WARRANTY OR WARRANTY REMEDY FAILS OF ITS ESSENTIAL PURPOSE, OR IS HELD TO BE INVALID OR UNENFORCEABLE FOR ANY REASON, IN CONSIDERATION OF THE OTHER PROVISIONS OF THIS AGREEMENT, THE PARTIES AGREE THAT ALL LIABILITY LIMITATIONS WILL NEVERTHELESS REMAIN IN EFFECT.**

**Governing Law and Dispute Resolution.** This Agreement shall be governed by the internal laws of the State of Wisconsin, U.S.A. without resort to conflicts of law analysis. The parties agree the State courts located in Milwaukee, Wisconsin, U.S.A. shall have exclusive venue for any dispute concerning the enforceability, interpretation, or termination of this Agreement, and agree to bring any such action in this venue. The parties further agree to personal jurisdiction in such courts for any such dispute.

**Attorney fees, Collection Costs, and Indemnification.** Buyer agrees to defend and indemnify Seller against any claims, damages, or liability (including attorney fees) arising out of Buyer's violation of any law or breach of its obligations under this Agreement including, but not limited to, personal injury, death, or property damage. In addition, Buyer shall reimburse Seller all reasonable attorney fees and collection costs incurred by Seller to enforce its rights against Buyer under this Agreement.

**Manuals and Brochures.** Buyer shall communicate to Seller any special needs, pictorials, labels, warning signs, instructions, or language required for the manuals and brochures used for the products. Buyer agrees to pay a reasonable surcharge for additional manuals, special manuals, and brochures.

**Severability.** Any legally unenforceable provision may be severed from this Agreement, and the remaining terms and conditions will be enforced as a whole as if such provision had not be inserted herein.

**Waiver, Entire Agreement.** No waiver by either party of a right under this Agreement shall waive any other rights. These terms and conditions and any other writing signed by Seller constitute the entire agreement, and may not be modified other than in writing signed by Seller.



## STANDARD VILTER WARRANTY STATEMENT

Seller warrants the products it manufactures to be free from defects in material and workmanship for a period of eighteen (18) months from the date of shipment from Seller's manufacturing plant or twelve (12) months from date of installation at the initial end users location, whichever occurs first. In addition, Seller provides the following extended warranties: (a) three (3) years from the date of shipment on single screw compressor internal rotating parts, (b) two (2) years from the date of shipment on reciprocating compressors and single screw and reciprocating compressor parts, and (c) two (2) years on all other parts on a single screw compressor unit. Such warranties do not apply to ordinary wear and tear. Seller does not warrant that the product complies with any particular law or regulation not explicitly set forth in the specifications, and Buyer is responsible for ensuring that the product contains all features necessary to safely perform in Buyer's and its customer's plants and operations. Buyer must notify Seller of any warranty claim within ten (10) days after such claim arises, otherwise Buyer waives all rights to such claim. Products supplied by Seller, which are manufactured by others, are not warranted by Seller, but rather Seller merely passes through the manufacturer's warranty to Buyer.

**SELLER EXPRESSLY DISCLAIMS ALL OTHER WARRANTIES, WHETHER EXPRESS OR IMPLIED, INCLUDING THE IMPLIED WARRANTIES OF MERCHANTABILITY AND FITNESS FOR A PARTICULAR PURPOSE.**

Unless otherwise agreed in writing, Buyer's sole remedy for breach of warranty is, at Seller's option, the repair of the defect, the correction of the service, or the providing a replacement part FOB Seller's office. Seller will not be responsible for costs of dismantling, lost refrigerant, reassembling, or transporting the product. Further, Seller will not be liable for any other direct, indirect, consequential, incidental, or special damages arising out of a breach of warranty. **THESE WARRANTY REMEDIES ARE EXCLUSIVE AND ALL OTHER WARRANTY REMEDIES ARE EXCLUDED.** Products or parts for which a warranty claim is made are to be returned transportation prepaid to Seller's factory. Any improper use, corrosion, neglect, accident, operation beyond rated capacity, substitution of parts not approved by Seller, or any alteration or repair by others which, in Seller's judgement, adversely affects the Product, shall void all warranties and warranty obligations. Further, Seller shall not be liable under the above warranties should Buyer be in default of its payment obligations to Seller under this Agreement or any credit agreement.

## VMC Compressor Operational Flowchart

(The values referenced in this flowchart are default values.)

### Requirements to Start Compressor

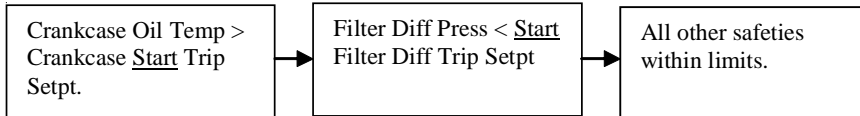

### Critical Compressor Run Logic @ Compressor Start

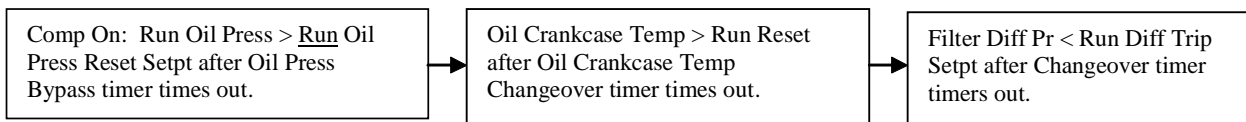

### Hi Suction Pressure Load Limiting

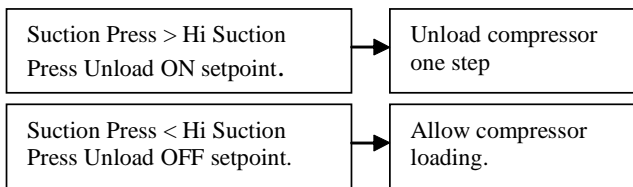

### High Dsch Pressure Load Limit

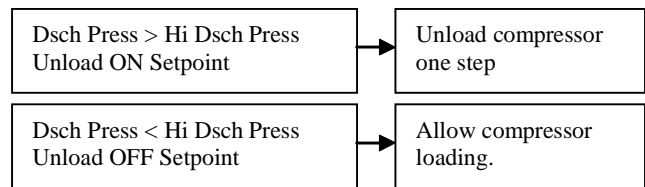

### Suction Press Over-ride Load Limit during Temperature Control

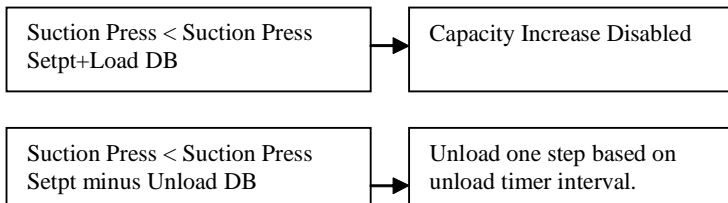



## Wiring Instructions For Vantage Only

### Mandatory Wiring

#### Step #1

#### Power Connections Required (#16 AWG. Nominal)

8-9= Main Power to Panel

8-8= Heater #1 Power

Neutral to 10-1

Ground to Lug

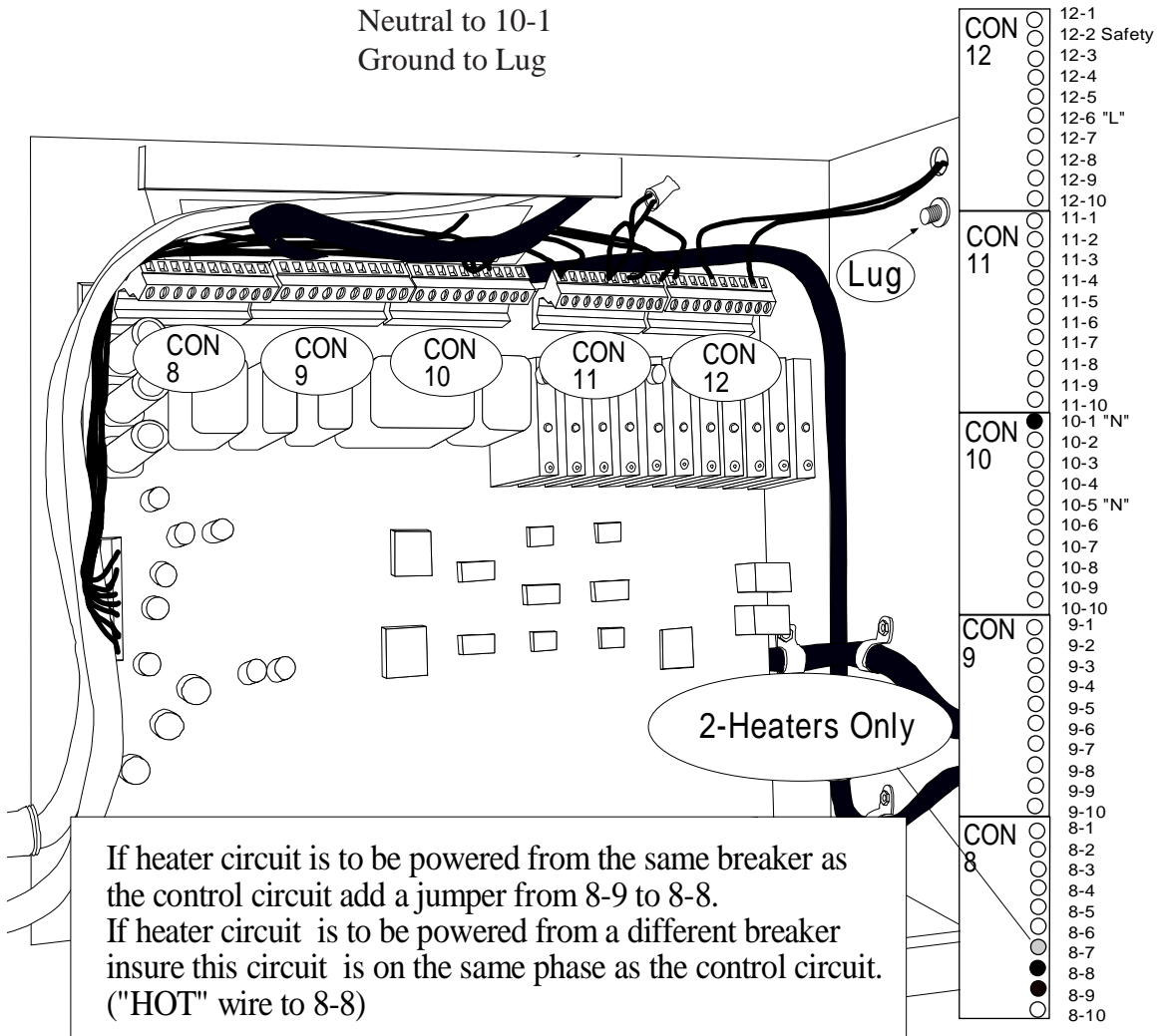

If heater circuit is to be powered from the same breaker as the control circuit add a jumper from 8-9 to 8-8.  
 If heater circuit is to be powered from a different breaker insure this circuit is on the same phase as the control circuit. ("HOT" wire to 8-8)

View Inside Of Vantage Panel

## Wiring Instructions For Vantage Only

### Mandatory Wiring

#### Step #2

#### Motor Starter Contactor Connection

The contact to pull-in the motor starter contactor is dry contact, place "control power wire from starter panel on 9-2. Place the wire to energize the starter contactor on 9-3.

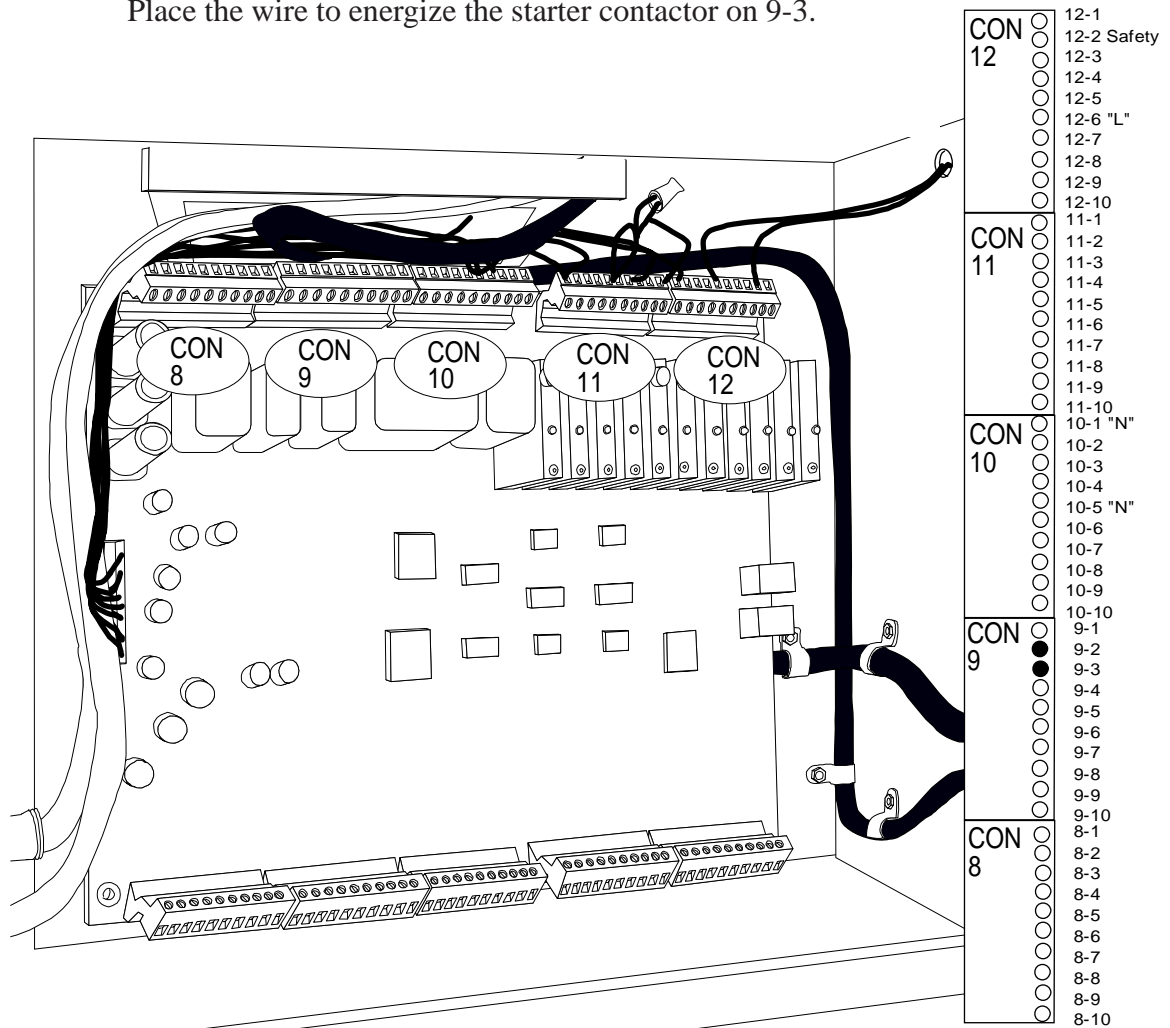

View Inside Of Vantage Panel

## Wiring Instructions For Vantage Only

### Optional Wiring

#### Step #3

#### Auxiliary / Safety Wiring

A determination by the user is to be made if this option will be used. If it is *not* used, insure that a jumper is installed between L 12-6 and 12-2.

If this option is used, remove the jumper 12-6 to 12-2 and place the high level cutout (typically, other cutouts or an E-stop could be used) common wire on 12-6 and the normally closed wire to 12-2.

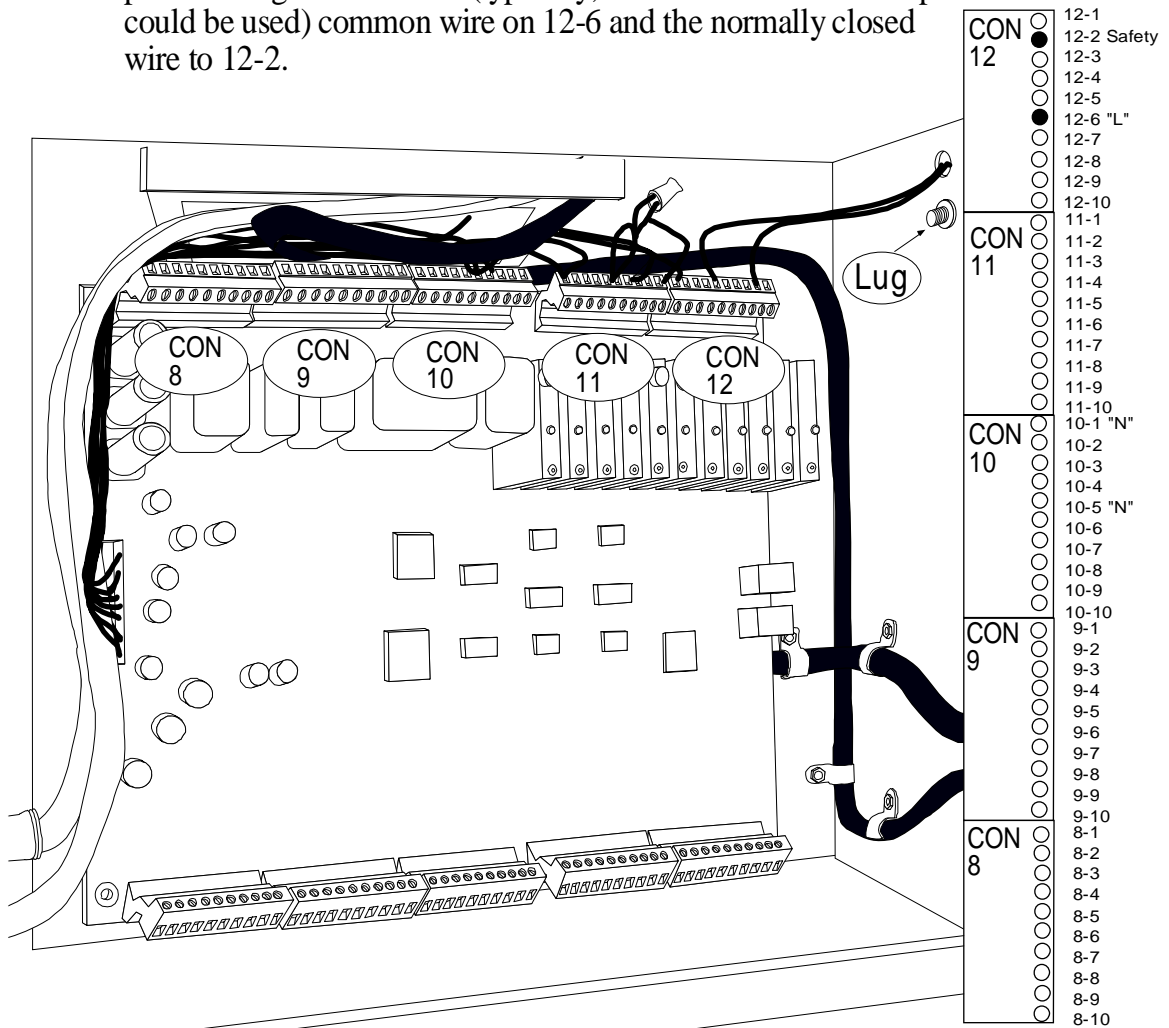

View Inside Of Vantage Panel

## Wiring Instructions For Vantage Only

### Optional Wiring

#### Step #4

#### Remote Start Wiring

A determination by the user is to be made if this option will be used. If it is *not* used, insure that a jumper is installed between L 12-6 and 12-5.

If this option is used, remove the jumper 12-6 to 12-5 and place the dry remote start contact common wire on 12-6 and the normally open wire to 12-5.

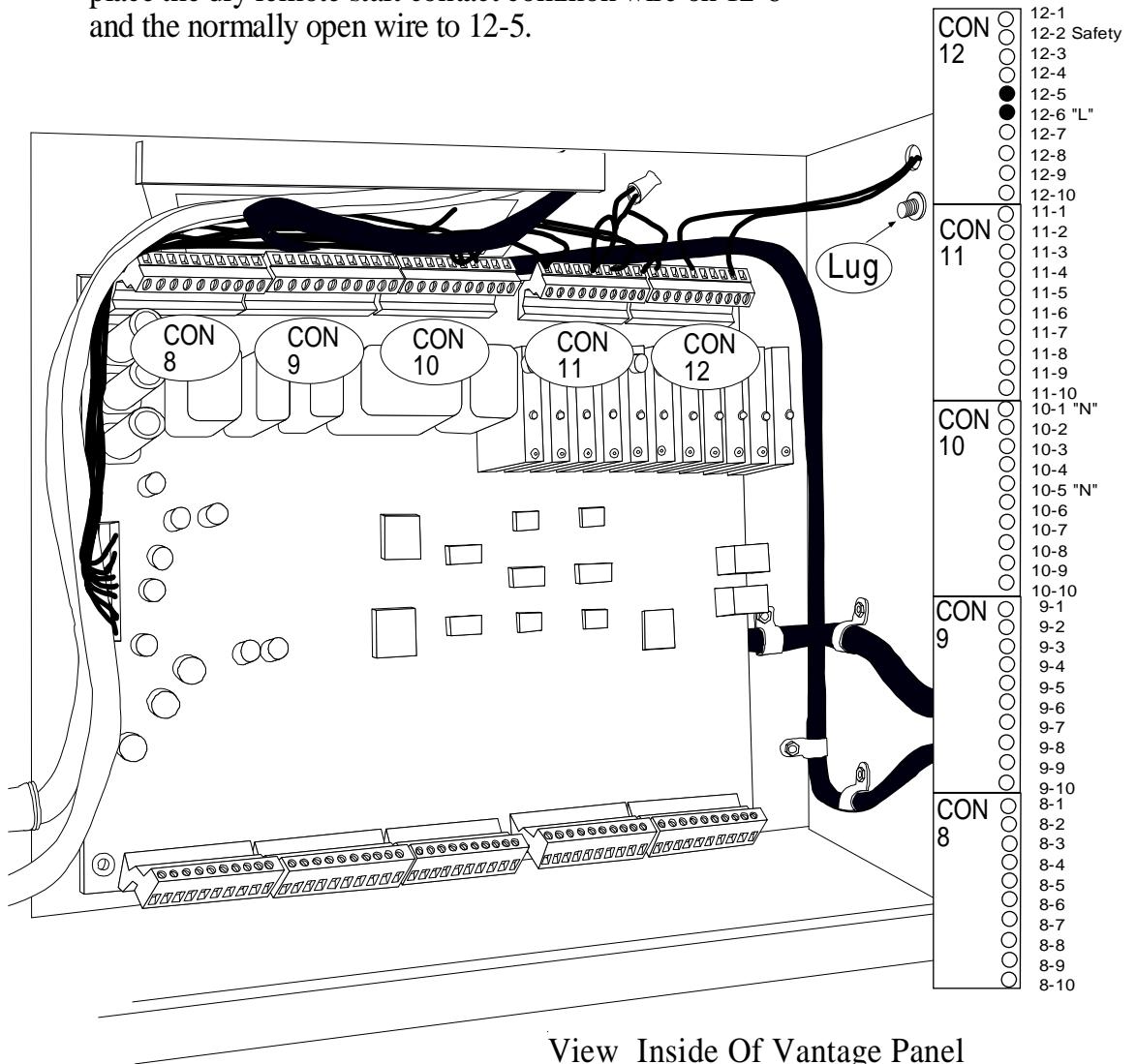

View Inside Of Vantage Panel

## Wiring Instructions For Vantage Only

### Mandatory Wiring

#### Step #5

Place a wire from 11-3 to one side of Motor Starter  
Auxiliary contact. From other side of Motor Auxiliary  
contact wire to 12-1

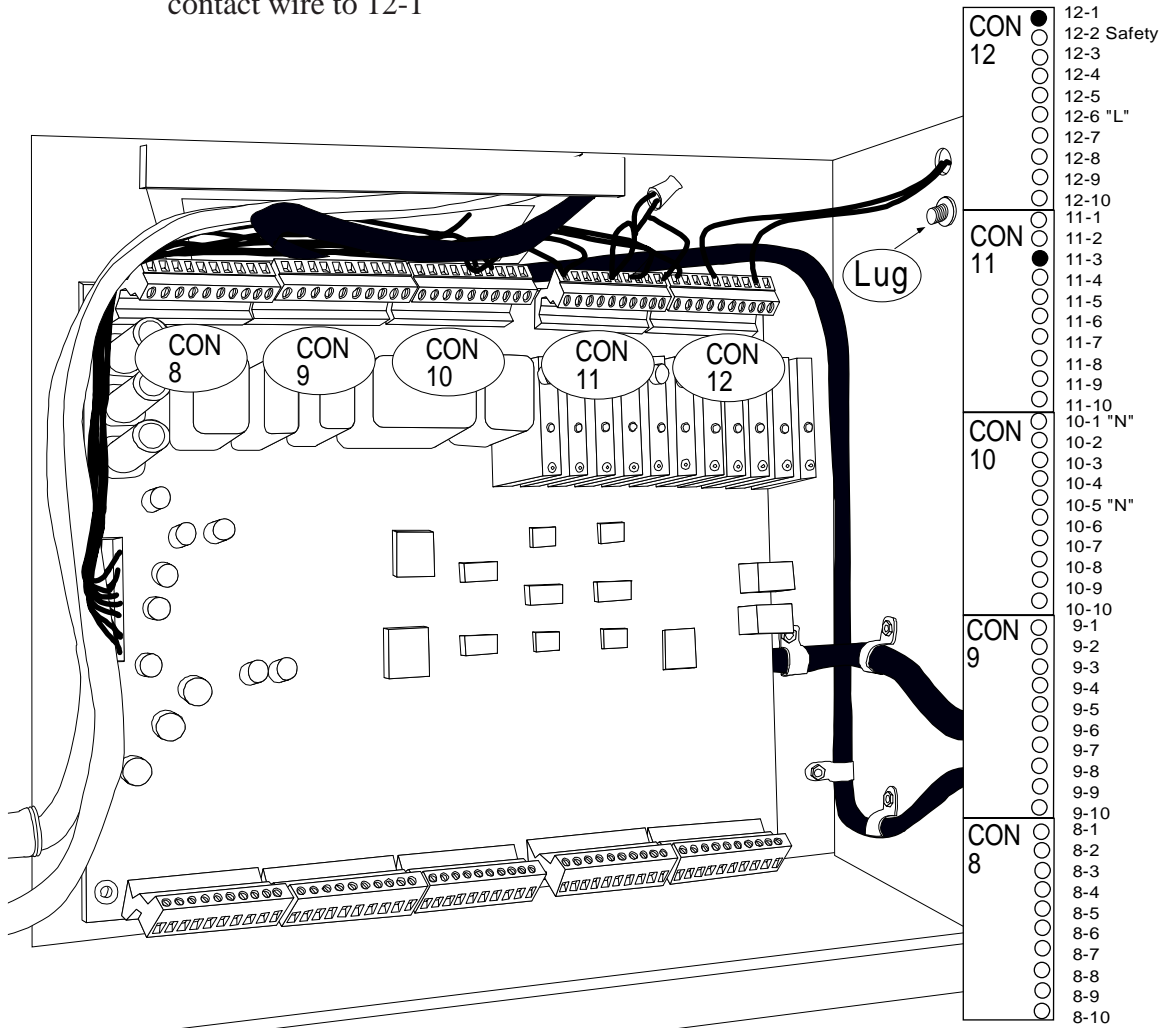

View Inside Of Vantage Panel





**Note Page**

## Wiring Diagram For Vantage Only

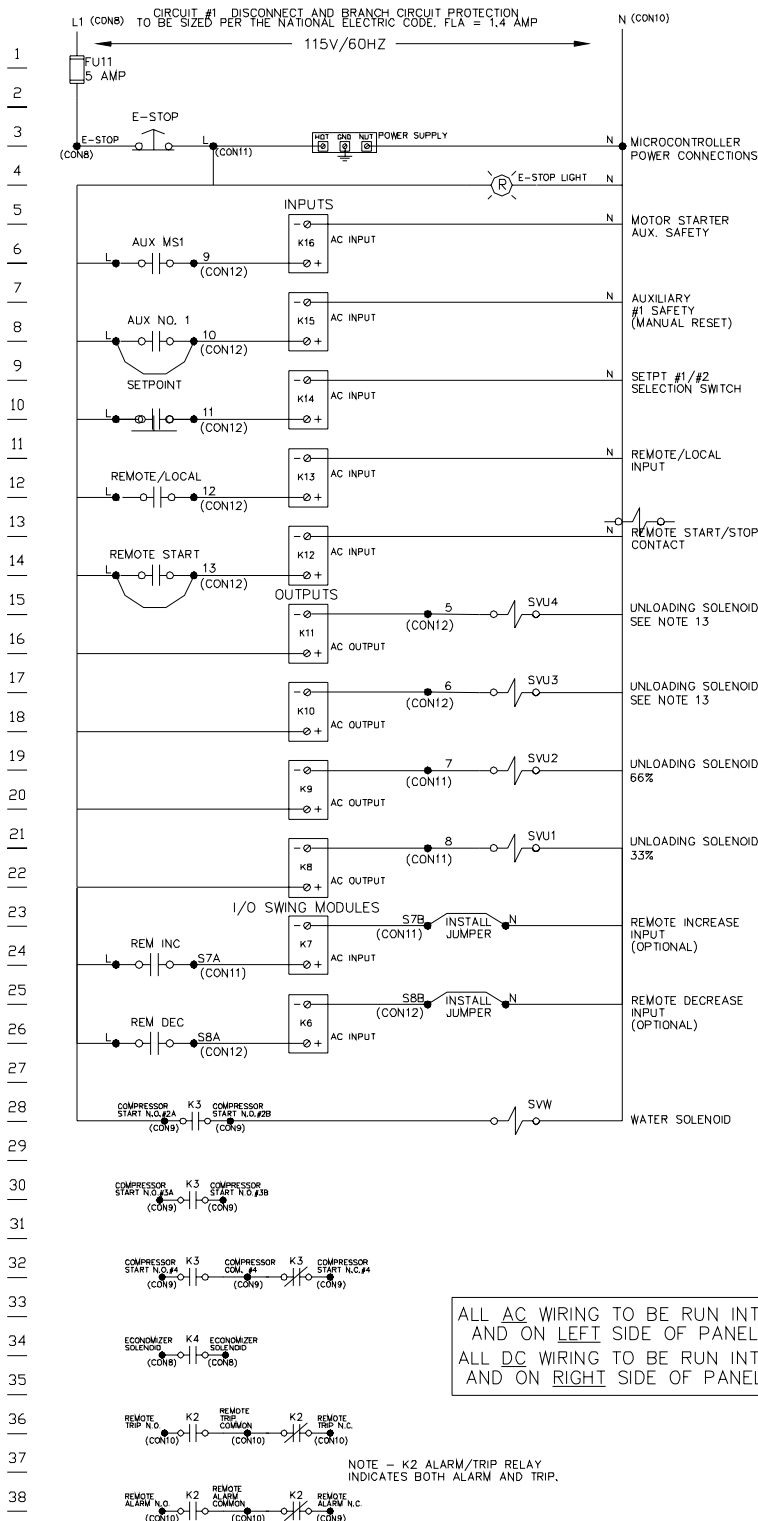

ALL AC WIRING TO BE RUN INTO AND ON LEFT SIDE OF PANEL  
ALL DC WIRING TO BE RUN INTO AND ON RIGHT SIDE OF PANEL

NOTE - K2 ALARM/TRIP RELAY INDICATES BOTH ALARM AND TRIP.

## Wiring Diagram For Vantage Only

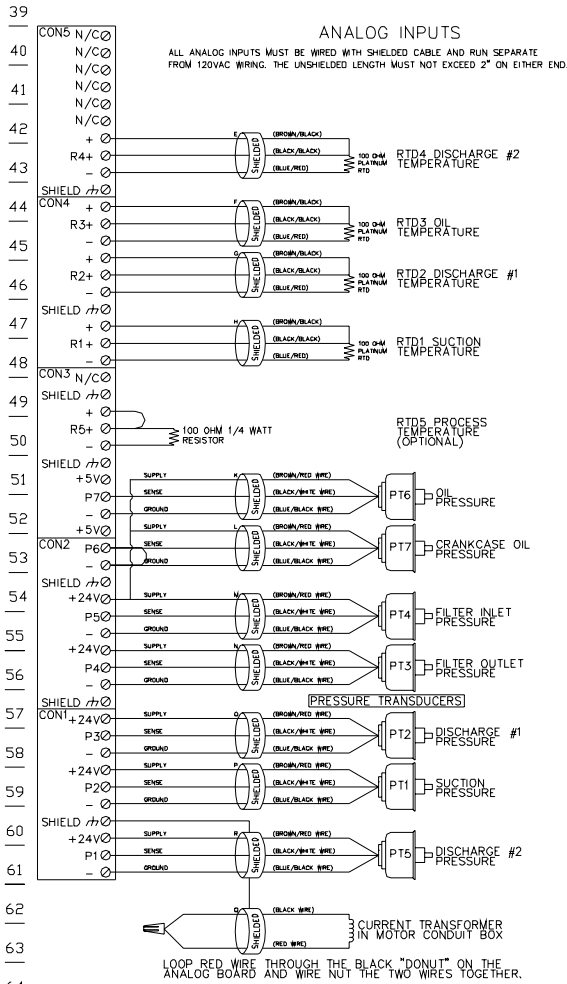

### 120VAC TERMINAL BLOCK LAYOUT

77	CON12	Ø	MOTOR STARTER AUX. SAFETY
78	Ø	Ø	AUXILIARY #1 SAFETY
79	Ø	Ø	SETP #1/#2 SELECTION SWITCH
80	Ø	Ø	LOW OIL SEPARATOR LEVEL SWITCH
81	Ø	Ø	REMOTE START/STOP CONTACT
82	Ø	Ø	L
83	Ø	Ø	L
84	Ø	Ø	L
85	Ø	Ø	L
86	Ø	Ø	L
87	Ø	Ø	L
88	Ø	Ø	L
89	Ø	Ø	L
90	Ø	Ø	L
91	Ø	Ø	L
92	Ø	Ø	L
93	Ø	Ø	L
94	Ø	Ø	L
95	Ø	Ø	L
96	Ø	Ø	L
97	Ø	Ø	L
98	Ø	Ø	L
99	Ø	Ø	L

### NOTES:

- 1) WIRING PER NEMA 12.
- 2) CONTROL WIRING #18 AWG. HEATER WIRING #16 AWG. JC COLOR CODE UNLESS OTHERWISE NOTED.
- 3) USE COPPER WIRE WITH AN INSULATION TEMPERATURE RATING OF 60°C MINIMUM.
- 4) DOTTED WIRING REPRESENTS FIELD WIRING.
- 5) DOTTED COMPONENTS NOT BY VILTER.
- 6) ● DENOTES CONNECTOR IN VILTER CONTROL PANEL.
- 7) FOR NEMA 3, 3R, 4 & 12 PANELS, ALL OPENINGS TO BE GASKETED.
- 8) MOTOR STARTER WIRING WILL VARY. REFER TO STARTER MANUFACTURER'S DIAGRAM FOR ACTUAL W.
- 9) ALL CONDUIT CONNECTIONS TO THE PANEL MUST BE MADE WITH FLEXIBLE CONDUIT.
- 10) "L" TERMINALS ARE LOCATED ON CONNECTORS CON11 AND CON12 AS NECESSARY.
- 11) "N" TERMINALS ARE LOCATED ON CONNECTORS CON10 AND CON11 AS NECESSARY.
- 12) TORQUE ON TERMINALS 3-7 INCH POUNDS.
- 13) WIRING TO UNLOADING SOLENOID VALVES AND AC OUTPUT WILL BE PROVIDED ONLY WHEN UNLOADING SOLENOID VALVE IS PROVIDED.

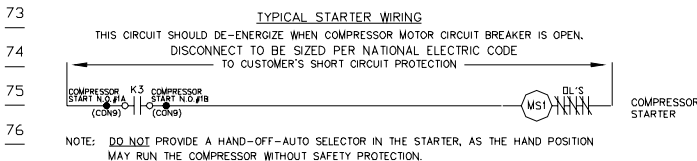
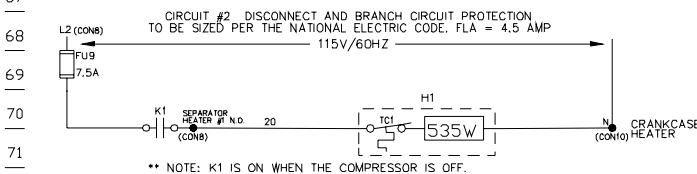

# Modbus Details

## COMPRESSOR RS-232 AND RS-422

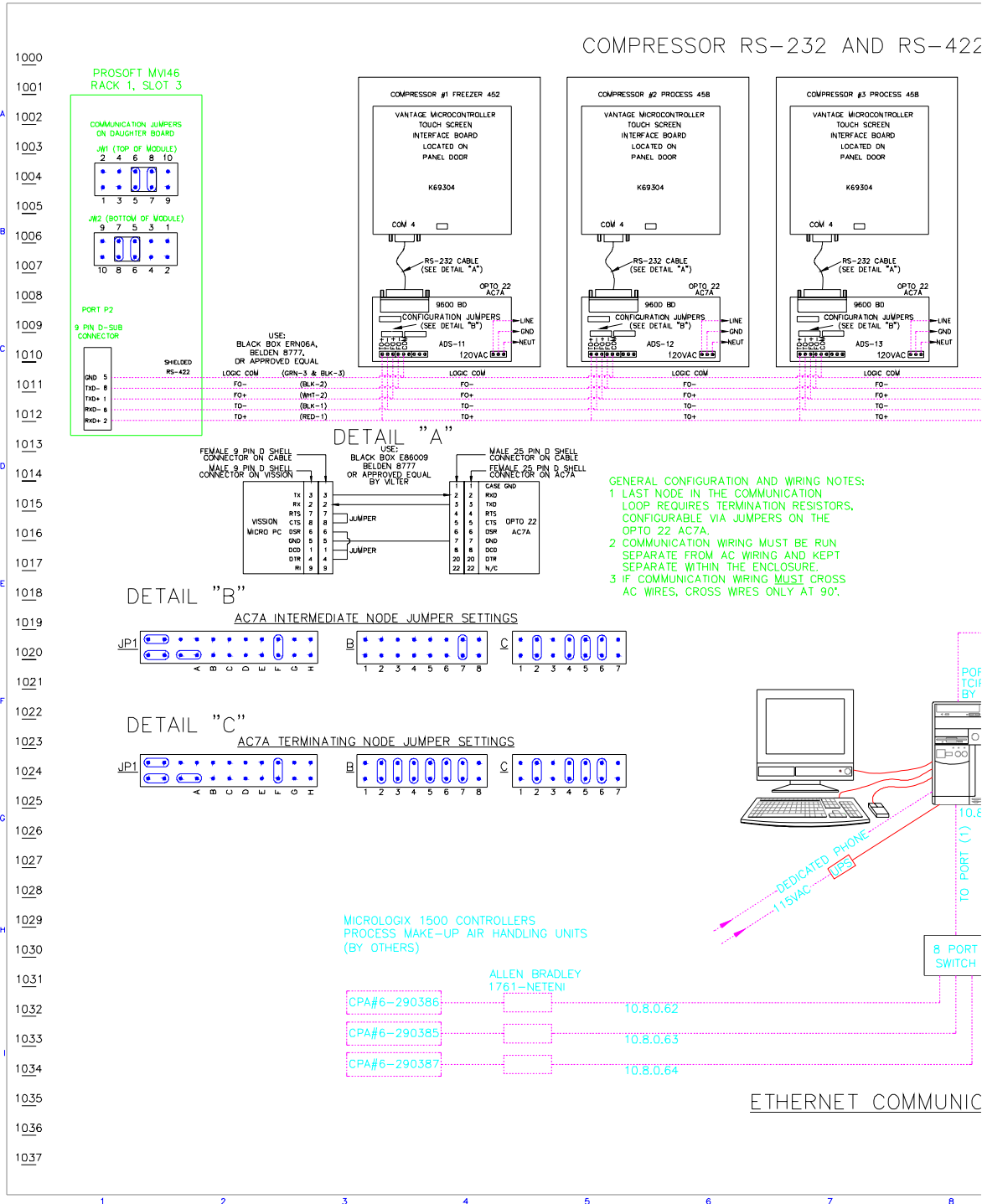

# Modbus Details

## 22 MODBUS COMMUNICATION WIRING

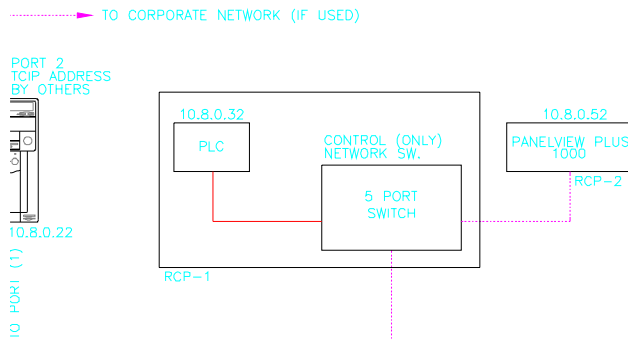
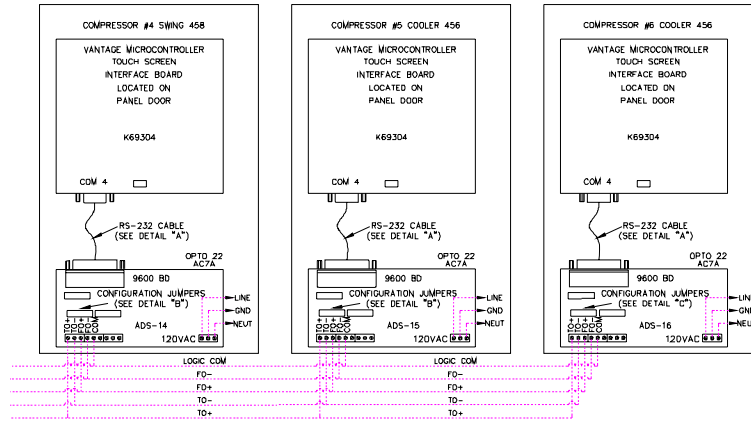

NOTES:  
 1) DOTTED WIRING REPRESENTS FIELD WIRING.  
 2) DOTTED COMPONENTS NOT BY VILTER.

(LOCATED IN CEILING)

### COMMUNICATION WIRING

R10	CUST. CHNG: REMOTE RESETS SEE ECN CM072257	MRM	MRM	8/21/07	R2	AS BUILTS. SEE ECN CM062263	CAK	MRM	8/25/06		
R9	ADDED TDR TIMERS & RELAYS. SEE ECN CM072064	CAK	WF	2/14/07	R1	UPDATES, FOR REVIEW	CAK	WF	7/24/06		
ITEM	SYM	REVISION	DRAWN	APPR.	DATE	ITEM	SYM	REVISION	DRAWN BY	APPR. BY	DATE
9			10			11			12		13
									14		15

INITIAL ISSUE CM062211

1 COMMUNICATION NETWORK WIRING

CONFIDENTIAL PROPERTY OF

VILTER MANUFACTURING CORPORATION  
 CUDAHY, WISCONSIN 53110-8904  
 TELEPHONE: (262) 744-0111

DRAWN BY: CAK    CHECKED BY: MRM    SCALE: N.T.S.  
 REDESIGNED BY: CAK    APPROVED BY: MRM    DATE: 7/19/06

TITLE: COMMUNICATION NETWORK WIRING  
 FOR: KEMPER/MARATHON CHEESE - MOUNTAIN HOME, ID

CHECK NO. K69305    06M125-1R10

In consideration of the receipt of this document, the recipient agrees not to reproduce, copy, use or forward this document and/or the information therein contained, in whole or in part, or to store such portion by electronic or any other means, without the written permission of Vilter Manufacturing Corporation and further agrees to return same to Vilter Manufacturing Corporation upon demand.

“Modbus Network - this drawing shows the interconnecting wiring and necessary jumper settings on the AC7A RS232 / RS422 convertor. It also shows jumper settings on for the PLC Prosoft Module.

## Main Screen

### The Main Screen

This screen has been designed to give the operator an overall view of all operating parameters affecting the compressor package. **This screen should always be displayed when maintenance items and setpoint items are not being performed.** The date on the screen is updated every 1/2 second. Status information such as Alarms and Trips are displayed on the screen.

The main screen contains the following items:

- Buttons to navigate to setpoint, setup and maintenance screens.
- Status information on the compressor, oil heater and run mode.
- Start/Stop buttons.
- Hour meter.
- Motor amperage.
- Refrigerant.
- Real time compressor and package operating conditions.
- Current Compressor Loading.

From the **Main** screen, touch the Setup button. After entering an authorized password, the screen pictured below will appear.

- **Operator Name** – This is the same list that appears in the login dialog. Names in this list can be selected for deletion. To change a name or password, you delete the name and enter a new name/password pair. The VILTER operator name cannot be deleted. Emergency passwords provided by a Vilter representative for the **VILTER** name are good only on the date for which they are issued. They are intended to permit navigation to this screen for setup or repair of this list.
- **Language** – The user screens can be seen in English, French, and Spanish, depending on the option selected. Some text will still display in English even when another language is selected.
- **Pressure Units** – Select units of measure for pressure readings. Choices are psi, kg cm<sup>2</sup> and kPa. Affects pressures displayed on main screen. On other screens, units are displayed in psi. On the main screen with psi selected, negative gauge

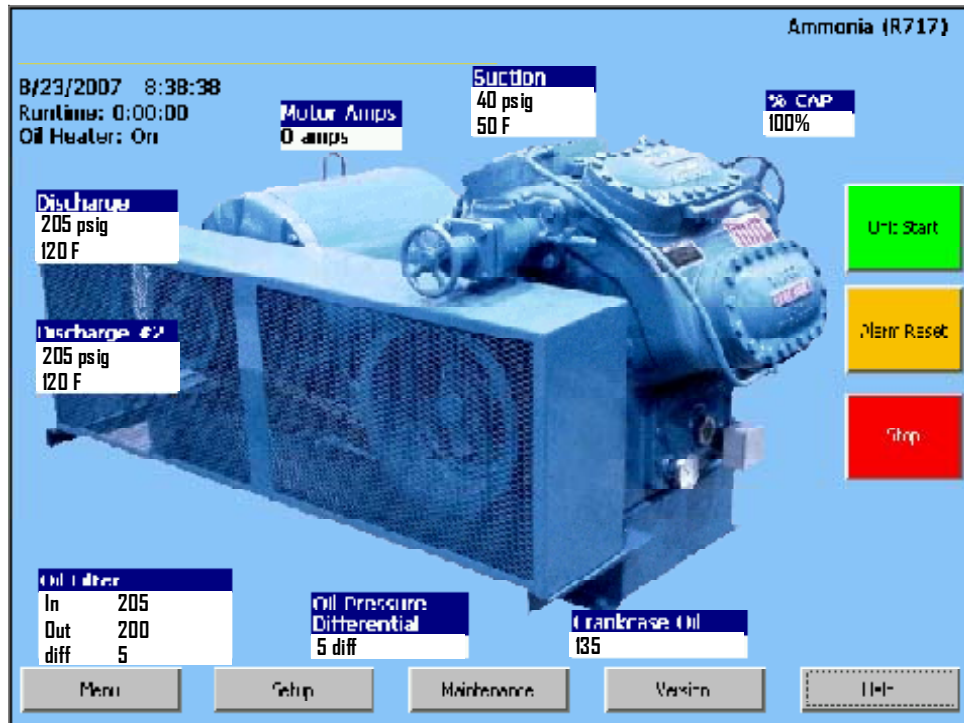

## Set Up Screen

pressures will display as inches of mercury vacuum with the unit “Hg. On other screens, negative numbers are scaled as “Hg.

- **Temperature Units** – Select units of measure for temperature. Choices are Fahrenheit or Celsius.
- **Refrigerant** – Select refrigerant type being used.
- **Anti-Recycle** – The operator can select from the following AntiRecycle options: True, Accumulative, Modified, or Hot Starts. These select the strategy used to prevent excessive start/stop cycles of the compressor. Timers and counters used to enforce anti-recycling are adjusted and monitored in the Compressor Timer Settings screen, reached from the **Menu** screen. Help for the Timer Settings screen explains how the different settings and strategies operate.

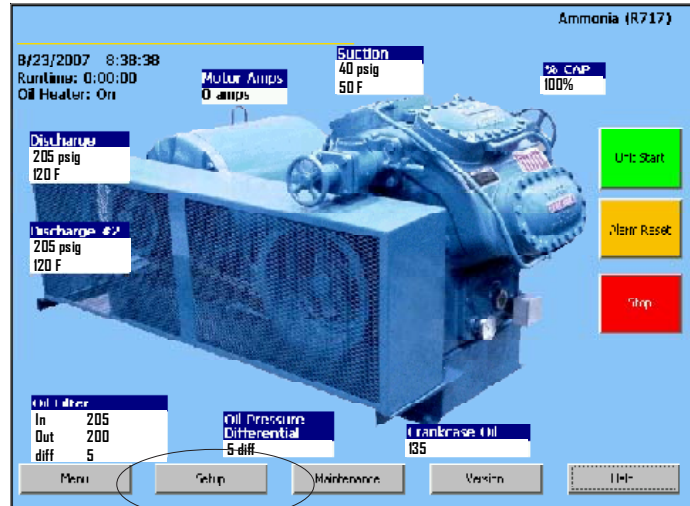

Touch Here

- **Compressor Control Via** – Operator can choose the method or mode of compressor control. This determines which measured variable is used in making loading (capacity control) decisions. The choice selected here determines which setpoints are made available for adjustment on the Compressor Control Setpoints screen.

- **Delete Operator** – Operator can choose to delete operator names from the authorized operator listing. A name in the list is selected by touching it. The selected name will be deleted from the list when this button is pushed. If you delete all the names (besides VILTER), be sure you add at least one before leaving this screen.

- **Add Operator** – This button will take you to the screen pictured in Figure 2. The button opens a dialog for entry of a new name/password pair. Nothing (leaving the password text box blank) is a legal password. The password is not obscured as it is typed in, so untrusted parties should not be permitted to view the screen during entry. The password is not confirmed with a repeat entry, so verify it visually before pressing okay. Up to 25 name/password pairs can be added. The Operator Name list box will acquire a scroll bar when it fills.

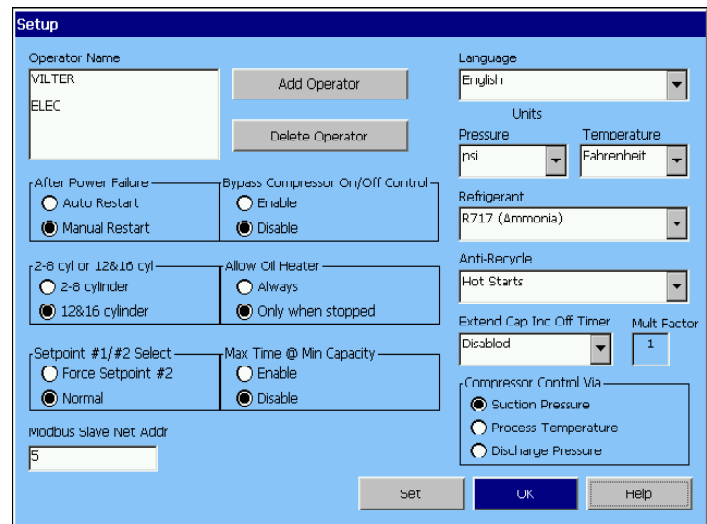



## Set Up Screen

- **Service Stop** – Enable and disable buttons permit selecting whether the operator is going to perform a ‘service stop’. The ‘service stop’ allows pumping the liquid refrigerant out of the oil separator, for service work. When selected, a dialog box pops up, instructing the operator to turn off the high pressure liquid hand valve. When the operator acknowledges the dialog box, the level master heater is turned off and the compressor enters the ‘service stop’ mode. When the discharge temperature rises to 8 deg. over saturation discharge temperature, the compressor is forced to unload to minimum capacity. When the discharge temperature rises to a value above the “High Dsch Temp Above Saturation Temp” setpoint, then the compressor will fail on this safety and turn off.
- **Modbus Slave Network Address** – When multiple MicroControllers are connected on a Modbus Network, each controller must have a unique address from the other MicroControllers on the network. Duplicate node addresses are not allowed. The node address of each Vission is determined through the **SETUP** menu. The MicroController that will initiate all conversation on the network **MUST** be defined as node 100 (this is defined as the “master” node). All other node numbers should be in the range of 101 through 174.
- This must be set when the extra special port (Com4) is used to control or monitor the compressor via Modbus. It also must be set when the multi-compressor sequencing feature is used. Even though Ethernet is used for the comms, this address establishes the compressor’s identity and role in the sequencing logic.
- **Reset After Power Fail** – When Auto is selected, the compressor will attempt to restart on powering up if it was running in ‘Auto’ when powered down and enabling conditions are met. When ‘Manual’ is selected, the compressor powers up into the ‘Stop’ mode and an explicit command to run is required from an operator or comms channel.
- **Bypass Compressor On/Off Control** – When the compressor is running, and this option is enabled, the compressor will NOT shutdown on the Pressure Control On/Off “OFF” setpoint. It will be bypassed. This option can be used to provide a one-shot “pumpdown”. Set the Suction Pressure Safety setpoint to an appropriate value to shut the compressor down when the suction pressure is pulled down. Caution - make sure the Suction Pressure Safety Setpoint is set appropriately, to prevent damage to the system.
- **2-8 cyl or 12&16 cylinder** – Select the appropriate setting for your compressor. This setting informs the control program to properly process the number of analog channels for your compressor. For instance, if 12&16 cylinder is selected, then the control program processes a second discharge temperature safety and a second discharge pressure safety.
- **Setpoint #1/#2 Select** – When Force Setpoint #2 is selected, normal control setpoint group selection by digital input K14 is overridden and control setpoint group #2 is always active.
- **Max Time @ Min Capacity** – When enabled, the compressor is allowed to run fully unloaded for a specific time period only (Max Time @ Min Capacity Timer). The criteria is that if the system pressure is less than Suction Pressure Setpoint minus the Unload Deadband, then the compressor will only be allowed to run for the time period of the Max Time @ Min Capacity Timer. This can be used to prevent heating of the cylinder heads.
- **Allow Oil Heater** -The “Allow Oil Heater” option allows selection of oil heater operation. Selecting “Always” will energize the heater relay at all times. If the heater has an integral thermostat, the heater will cycle on and off from that thermostat. Selecting “Only when stopped” will energize the heater relay only when the compressor has stopped. Some applications do not require the heater to be energized when the compressor is running.
- **Extended increase differential timer**- Does not apply to the Vantage Recip program.



## Log On, off or Save Changes

### Log On, Off, or Save Changes

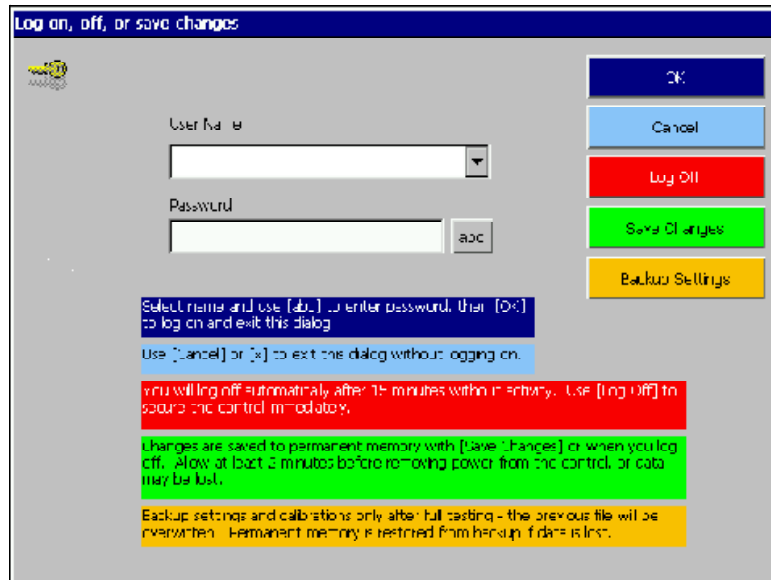

**Log on, off, or save changes**

User Name

Password  
 abc

Select name and use [Tab] to enter password. Then [OK] to log on and exit this dialog.

Use [Cancel] or [x] to exit the dialog without logging on.

You will log off automatically after 15 minutes with inactivity. Use [Log Off] to secure the control immediately.

Changes are saved to permanent memory with [Save Changes] or when you log off. Allow at least 2 minutes before removing power from the control, or data may be lost.

Backup settings and calibrations only after full testing - the previous file will be overwritten. Permanent memory is restored from backup if data is lost.

OK  
 Cancel  
 Log Off  
 Save Changes  
 Backup Settings

Press Log on/Save Button and the above screen will appear. When altering setpoints, log on is necessary. Select appropriate user name and enter password to change setpoints. This screen is also used to backup and save setpoints by pressing (Backup Settings).

After performing a “Back up Setting” operation, **DO NOT** power down the Vantage panel for atleast 1 minute. This will allow adequate time to insure all setpoints have been properly stored.

## Version Screen

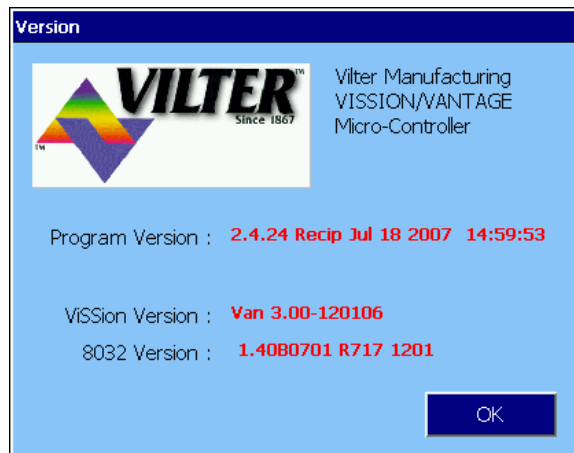

**Version**

 Vilter Manufacturing  
 VISSION/VANTAGE  
 Micro-Controller

Program Version : 2.4.24 Recip Jul 18 2007 14:59:53

VISSion Version : Van 3.00-120106

8032 Version : 1.40B0701 R717 1201

OK

To View if a customized program has been installed in your unit, go to the main screen and press VERSION, a screen will appear with the program version and the make model of the unit.

## Maintenance Screen

Ammonia (R717)

8/29/2007 8:38:38  
 Runtime: 0:00:00  
 Oil Heater: On

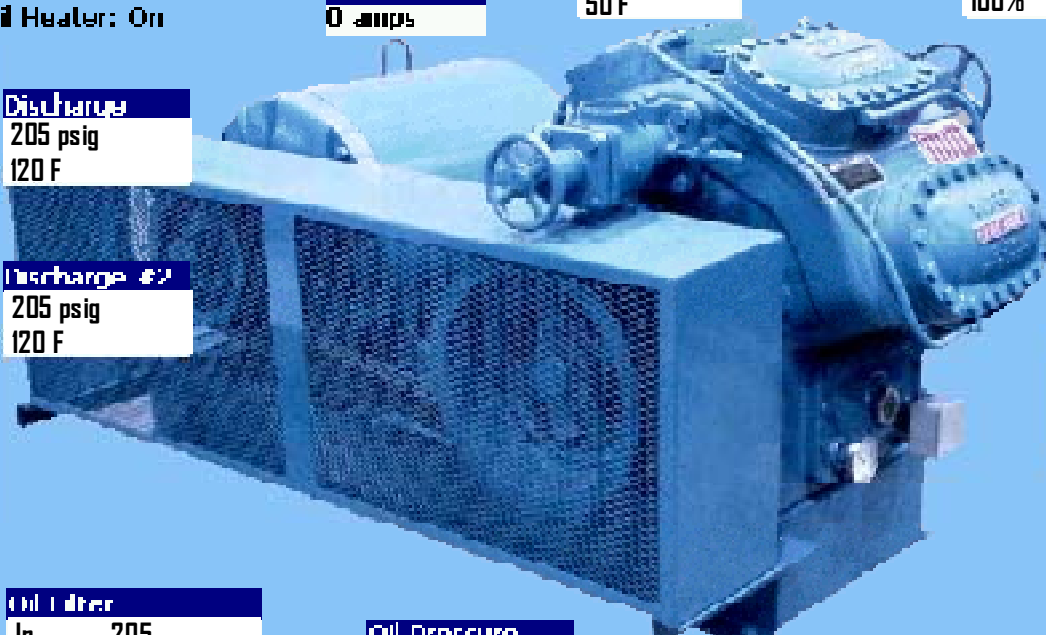
<b>Motor Amps</b> 0 amps	<b>Suction</b> 40 psig 50 F	<b>% CAP</b> 100%
<b>Discharge</b> 205 psig 120 F		
<b>Discharge #2</b> 205 psig 120 F		
<b>Oil Filter</b> In 205 Out 200 diff 5	<b>Oil Pressure Differential</b> 5 diff	<b>Crankcase Oil</b> 135

U-I Start

Alarm Reset

Stop

Menu

Setup

Maintenance

Version

Help

Touch Here

From the **Main** screen touch the Maintenance button.

## Maintenance Screen

### Maintenance Chart

GROUP	INSPECTION OR MAINTENANCE ITEM	SERVICE INTERVAL (HOURS)												
		200	5,000	10,000	20,000	30,000	40,000	50,000	60,000	70,000	80,000	90,000	100,000	110,000
<b>OIL CIRCUIT</b>														
	Oil Change (1)		R	R	R	R	R	R	R	R	R	R	R	R
	Oil Analysis (2)		S	S	S	S	S	S	S	S	S	S	S	S
	Oil Filters (3)	R	R	R	R	R	R	R	R	R	R	R	R	R
	Oil Strainer	I	I	I	I	I	I	I	I	I	I	I	I	I
<b>PACKAGE</b>														
	Coalescing Elements			I	R	I	R	I	R	I	R	I	R	I
	Suction Screen	I	I	I	I	I	I	I	I	I	I	I	I	I
	Liquid Line Strainers	I	I	I	I	I	I	I	I	I	I	I	I	I
	Coupling Alignment and Integrity	I	I	I	I	I	I	I	I	I	I	I	I	I
<b>CONTROL CALIBRATION</b>														
	Transducers	I	I	I	I	I	I	I	I	I	I	I	I	I
	RTD's	I	I	I	I	I	I	I	I	I	I	I	I	I
<b>COMPRESSOR</b>														
	Inspect Compressor		I	I	I	I	I	I	I	I	I	I	I	I
	Bearings		I	I	I	I	I	I	I	I	I	I	I	I

**Key**

- I Inspect.
- R Replace.
- S Sample.

**Notes:**

- (1) The oil should be changed at these intervals, unless oil analysis results exceed the allowable limits. The frequency of changes will depend on the system cleanliness.
- (2) Oil analysis should be done at these intervals as a minimum; the frequency of analysis will depend on system cleanliness.
- (3) The oil filter(s) on a minimum must be changed at these intervals or annually if not run continuously. However, the oil filter(s) must be changed if the oil filter differential exceeds 12 psi or oil analysis requires it.

OK

View Notes

Service

This screen shows the chart of routine maintenance to be performed on the machine at hourly intervals from 200 hours to 120,000 hours.

The Service Button from the Maintenance Screen will bring you to this screen.

### Services Completed

<input type="checkbox"/> Oil Change	<input type="checkbox"/> Coalescing Elements	<input type="checkbox"/> Transducer Calibration	<div style="background-color: #003366; color: white; padding: 5px; width: 60px; margin: 0 auto 5px auto;">OK</div> <div style="background-color: #ccc; padding: 5px; width: 100px; margin: 0 auto 5px auto;">Cancel</div> <div style="background-color: #ccc; padding: 5px; width: 100px; margin: 0 auto;">Add Note</div>
<input type="checkbox"/> Oil Analysis	<input type="checkbox"/> Suction Screen	<input type="checkbox"/> RTD Calibration	
<input type="checkbox"/> Oil Filters	<input type="checkbox"/> Liquid Line Strainers	<input type="checkbox"/> Inspect Compressor	
<input type="checkbox"/> Oil Strainer	<input type="checkbox"/> Coupling Alignment	<input type="checkbox"/> Inspect Bearings	

## Menu Screen

At the bottom of the **Main** screen touch the Menu button to bring up the screen shown in Figure below.

Use this screen to navigate to the other setpoint screens contained within the program. Each setpoint has a help button to described the function of the screen.

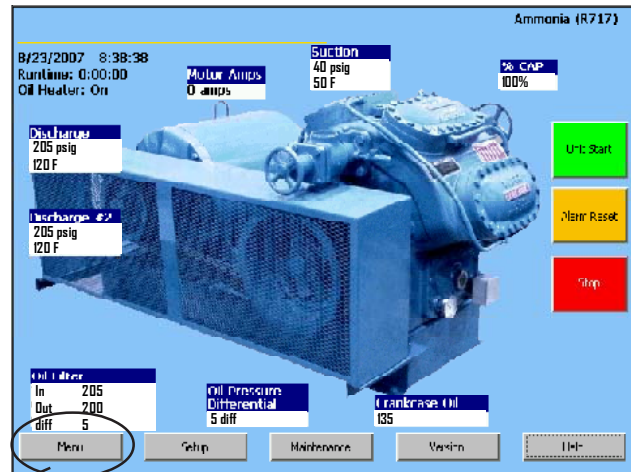

Touch Here

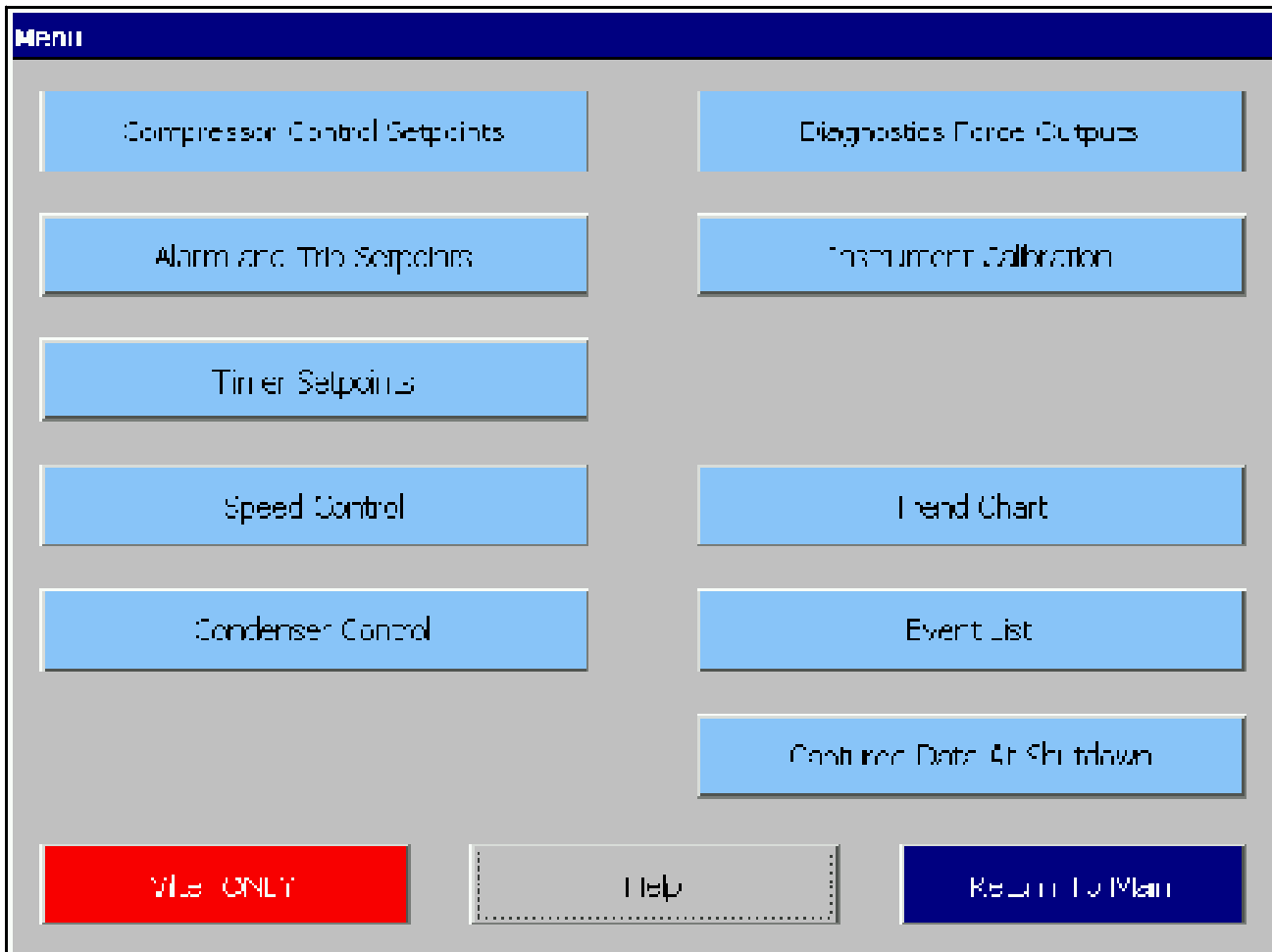

## Common Buttons

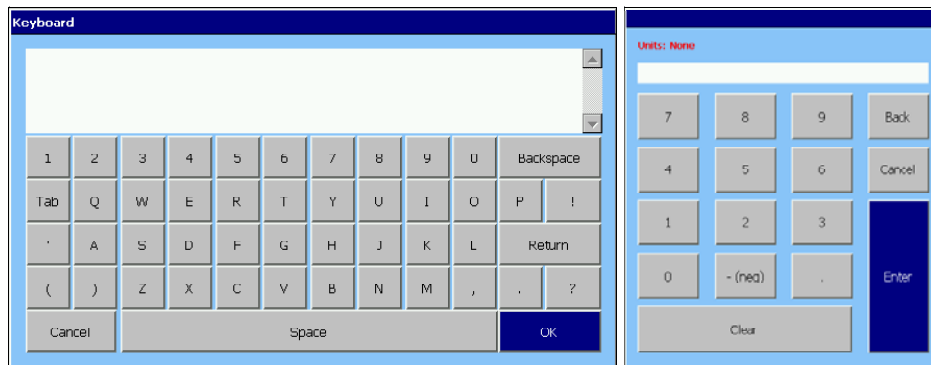
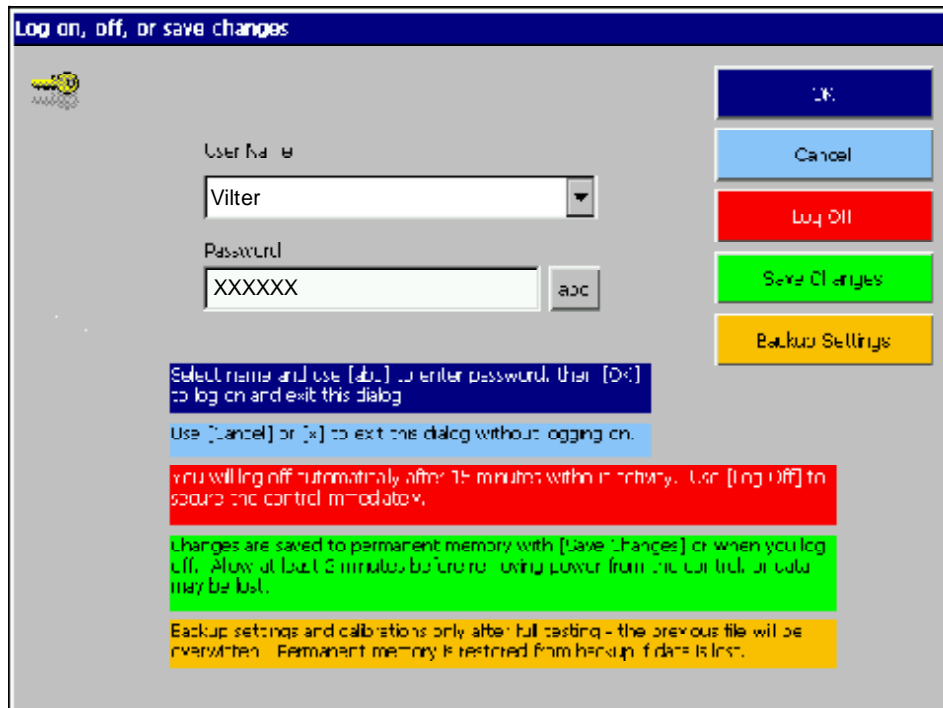

### A. Common Buttons

There are several buttons that are common for all menu screens:

- **Return to Menu** – This button always returns you to the **Menu** screen
- **Logon To Edit** – The user is allowed to view data at all screen levels but cannot edit data until a login has occurred. In order to logon, press the arrow next to user name, select user then press the abc button, the key pad screen will appear. Enter your password and hit OK.
- **Set** – To change a value, the operator must first press the SET button and then the text field of the value they want to modify. A number pad will pop up for ease in entry.
- **Help** – This screen will provide more information to the user about the operator of the microprocessor.

## Compressor Control

**Compressor Control Setpoints (page 1 of 2)**

Pressure Control On/Off		On	Off	<input type="button" value="Next"/> <input type="button" value="Back to Menu"/> <input type="button" value="Load On to EJT"/> <input type="button" value="Set"/> <input type="button" value="Help"/>
Setpoint No. 1		22.0 psig	15.0 psig	
Setpoint No. 2		27.0 psig	18.0 psig	
Pressure Control Setpoints		On/Off		
Setpoint No. 1		18.0 psig		<input type="button" value="Capacity"/> <input type="button" value="Menu"/>
Setpoint No. 2		23.0 psig		
Load Deadband		Setpoint No. 1	10.0 psig	
		Setpoint No. 2	23.0 psig	
Unload Deadband		Setpoint No. 1	20.0 psig	
		Setpoint No. 2	25.0 psig	

Load Timer Interval      
 Unload Timer Interval

### Level 1 Access – Compressor Control Setpoints

From the **Menu** screen , press the Compressor Control setpoints button. The compressor control setpoints screen will be shown.

- **Pressure Control On/Off** : The compressor will automatically cycle ON and OFF at the setpoints entered. Suction Pressure On/Off control is only active if the Compressor Control via Suction Pressure option is selected on the SETUP screen. If a compressor shut down is desired on a suction pressure drop and a manual reset is required, set the OFF value below the Low Suction Pressure safety trip value. This will shut down the unit and a reset will be required to restart it.
- **Pressure Control Setpoint** : This is the suction pressure control setpoint that the compressor will operate at when the compressor is in the Auto mode.
- **Load Deadband** : This value is added to the Pressure Control Setpoint to determine at what suction pressure the compressor will load when running.
- **Unload Deadband** : This value is subtracted from the Pressure Control Setpoint, to determine at what suction pressure the compressor will unload.
- **Capacity Control °F On/Off** : The compressor will automatically cycle ON and OFF at the setpoints entered. Capacity Control °F On/Off is only active if the Compressor Control via Process Temperature option is selected on the SETUP screen. If compressor shut down is desired on a process temperature drop and a manual reset is required, set the OFF value below the Low Control Temperature safety trip value. This will shut down the unit and a reset will be required to restart it.

## Compressor Control

- **Temperature Control Setpoint** : This is the process temperature control setpoint that the compressor will operate at when the compressor is in the Auto mode.
- **Load Deadband** : This value is added to the Temperature Control Setpoint to determine at what suction pressure the compressor will load when running.
- **Unload Deadband** : This value is subtracted from the Temperature Control Setpoint, to determine at what suction pressure the compressor will unload.
- **Process Temperature: Control** provides for a Suction Pressure Over-ride feature. If the suction pressure should drop below the (Suction Pressure Control Setpoint plus the Load Deadband), the Suction Pressure will then override the Temperature Control Capacity Increase setpoint and prevent the compressor capacity from increasing (loading). If the suction pressure should continue to decrease below the (Suction Pressure Control Setpoint minus the Unload Deadband), the compressor capacity will be forced to decrease one step. It will continue to decrease at the rate of the Load and Unload interval timers until the suction pressure is just above the (Suction Pressure Control Setpoint minus the Unload Deadband) value. This will help stabilize the suction pressure, allowing for the process temperature to be gradually pulled down. The Suction Pressure Capacity Setpoints can be viewed or adjusted by temporarily selecting “Processor Control Via .. Suction Pressure” on the Setup screen.
- **Load Interval Timer** : This timer establishes the delay between steps of loading. When the Suction Control Setpoint Pressure plus the Load Deadband value is equal to or less than the system pressure, this timer will start. If the condition persists after the time delay, the compressor will load one step.
- **Unload Interval Timer** : This value establishes the delay between steps of unloading. When the Suction Setpoint Control Pressure minus the Unload Deadband value is greater than the system pressure, the timer will start. If the condition persists after the time delay, the compressor will unload one step.

## Additional Compressor Controls

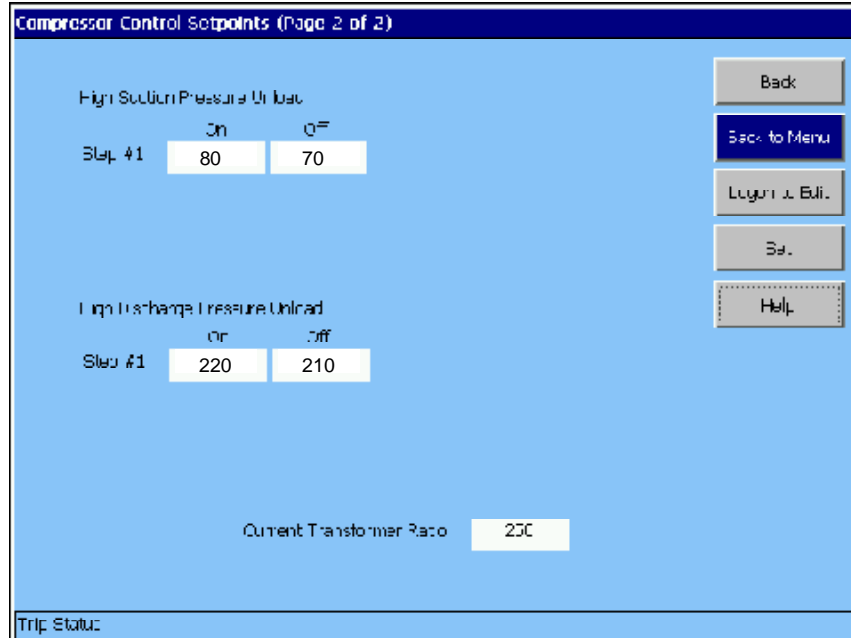

**Hi Suction Pressure Unloading Setpoints** - This will prevent the compressor motor from overloading if there is an increase in suction pressure (such as initial system pulldown). When the suction pressure increases above the on setpoint, the compressor will unload. If the suction pressure continues to increase, the next unloader step will unload. The number of unloading steps available depends upon the compressor unloading available.

**Note:** *The compressor will stay unloaded until the suction pressure decreases below the OFF setpoint.*

**High Discharge Pressure Unloading Setpoints** - Active in Suction Pressure or Process Temperature Capacity Control mode. These setpoints limit the compressor from loading at high discharge pressure conditions. They override the Suction Pressure or Process Temperature Capacity Control Setpoints. The number of unloading steps available depends upon the compressor unloading available.

These setpoints will unload the compressor when the discharge pressure reaches the ON point for a step of capacity. The compressor will be allowed to load again when the discharge pressure drops below the OFF setpoint. Each step of capacity has an ON and OFF setpoint associated with it. These setpoints should be set below the High Discharge Pressure Safety Setpoint to allow the compressor to unload, reducing head pressure, in an attempt to prevent the compressor from shutting down on High Discharge Pressure.

**Current Transformer Ratio** - The value entered must agree with the Current Transformer Ratio on the current transformer being used. The current transformer is mounted in the compressor motor conduit box. The ratio is stated as the ratio of measured current to a nominal full scale current in the secondary of 5 amps; only the first of these is entered. For example if the ratio reads 250/5, enter 250.





**Note Page**



## Compressor Alarm and Trip

**Alarm and Trip Setpoints [Page 1 of 2]**

	Alarm	Trip	Reset
<b>Low Suction Pressure</b>			
Setpoint No. 1	3.1 "Hg	4.1 "Hg	2.0 "Hg
Setpoint No. 2	1.0 "Hg	2.0 "Hg	0.0 psig
<b>High Discharge Pressure</b>			
Setpoint No. 1	210 psig	220 psig	205 psig
Setpoint No. 2	220 psig	230 psig	215 psig
Low Suction Temperature	-45 °F	-50 °F	-40 °F
High Discharge Temperature	205 °F	210 °F	200 °F
Low Crankcase Oil Temp - start	75 °F	70 °F	80 °F
Low Crankcase Oil Temp - run	105 °F	100 °F	110 °F
Low Control Temperature	-50 °F	-55 °F	-45 °F
High Control Temperature	100 °F		95 °F

Trip Status

- Compressor Safeties**  
 Low Suction Pressure Setpoints 1 and 2 : This is the low suction pressure safety. This safety is active in both temperature and pressure control modes. An alarm or trip will be active on a drop in suction pressure below the setpoint value.
- High Discharge Pressure Setpoints 1 and 2 :** This is the high discharge pressure safety. The alarm or trip will be active on a rise in discharge pressure above the setpoint value.
- High Discharge #2 Pressure Setpoints 1 and 2 :** Only active if the recip is selected as a 12-16 cylinder compressor (from the Setup Menu). The alarm or trip will be active on a rise in discharge #2 pressure above the setpoint value.
- Low Suction Temperature :** This is the low suction temperature safety. The alarm or trip will be active if the suction temperature should drop below the setpoint value.
- High Discharge Temperature #1 :** This is the high discharge temperature safety. The alarm or trip will be active if the discharge temperature should rise above the setpoint value.
- Low Crankcase Oil Temperature - start :** This is the starting low oil crankcase temperature safety. The compressor is prevented from starting or running if the oil in the crankcase is below the trip value. After a time delay (Crankcase Oil Temperature Safety Changeover), this safety is deactivated and the Lo Crankcase Oil Temperature - run safety is the active setpoint.

## Compressor Alarm and Trip

- **Low Crankcase Oil Temperature - run :**  
This is the running low crankcase temperature safety. After a time delay, (Crankcase Oil Temperature Safety Changeover), the Low Crankcase Oil Temperature - start safety is bypassed and Low Crankcase Oil Temperature - run safety is the active setpoint. The alarm or trip will be active if the oil temperature in the crankcase drops below the setpoint value.
- **High Discharge Temperature #2 :** Only active if the recip is selected as a 12-16 cylinder compressor (from the Setup Menu). This is the high discharge #2 temperature safety. The alarm or trip will be active if the discharge #2 temperature should rise above the setpoint value.
- **Low Control Temperature :** This is the low control temperature safety. This safety is active when process temperature control has been selected in the Setup Screen. An alarm or trip will be active on a drop in Process temperature below the setpoint value.
- **High Control Temperature :** This is the high control temperature safety. This safety is active when the temperature control has been selected in the Setup Screen. An alarm will be active on an increase in Process temperature above the setpoint value.



## Compressor Setpoints and Alarms

Compressor Alarm and Trip Setpoints [Page 2 of 2]

	Alarm	Trip	Reset
High Crankcase Oil Temp	210 °F	220 °F	205 °F
Low Oil Pressure	38 psig	35 psig	40 psig
High Fltr. Diff. Press. -Start	45 psid	50 psid	25 psid
High Fltr. Diff. Press. -Run	12 psid	15 psid	10 psid

Buttons: Back, Back to Menu, Lock On to Edit, Set, Help

Trip Status

- Hi Crankcase Oil Temp:** The safety is active at all times. A trip condition will exist when the Crankcase temperature is above the Trip setpoint.
- Low Oil Pressure :** This is the running oil pressure safety. An alarm or trip will be active if the oil pressure should drop below the setpoint value. This occurs once the Oil Pressure Bypass timer has expired. This time limit is set on the Compressor Timer Setpoints screen. For the single stage reciprocating compressor, oil pressure is defined as manifold pressure minus suction pressure. For an integral 2 stage reciprocating compressor, oil pressure is defined as manifold pressure minus crankcase pressure.
- High Filter Differential Pressure Start :** This safety setpoint is active when the compressor is in the start cycle. An alarm or trip will be active if the filter inlet pressure exceeds the filter outlet pressure by the setpoint value.
- High Filter Differential Pressure Run :** This safety setpoint is active when the compressor is in the run cycle. An alarm or trip will be active if the filter inlet pressure exceeds the filter outlet pressure by the setpoint value.

## Compressor Timer Setpoints

Compressor Timer Setpoints

	Current	Value	
Unloaded Start	0 sec	15 sec	Back to Menu
Max Time @ Min Capacity	0 min	1 min	Log On to Edit
Compressor Starter Aux. Contact Bypass	0 sec	10 sec	Set
Oil Pressure Bypass at Compressor Start	0 sec	60 sec	Help
Crankcase Oil Temp Safety Changeover	0 sec	300 sec	
Hi Discharge Temp Bypass @ Start	0 sec	30 sec	
After Power Failure	0 min	5 min	
Filter Diff. Pressure Safety Changeover	0 sec	60 sec	
True Anti-Recycle Timer	0 min	20 min	
Accumulative AntiRecycle Timer	0 min	20 min	
Number of Hot Starts per Hour	0	3	

**To change a timer setting, you must “Logon to Edit” first. Push the “Set” button then push on the timer setpoint value you wish to change. After the setpoint is changed, press the “Refresh” button. This will refresh the “Current” window, which shows the elapsed time of the timers.**

Trip Status

- **Unloaded Start** - At compressor startup, the capacity control will be at minimum position for this time period. After the timer expires, the capacity control steps are free to move in accordance to the system demands.
- **Max Time @ Min Capacity** - When the compressor is fully unloaded and the system pressure is less than Suction Pressure Control Setpoint minus the Unload Deadband, the compressor will be allowed to run for this time period. This is to prevent short-cycling. For the Maximum Time At Minimum Capacity Timer to be active, the Option must be selected from the Setup screen.
- **Compressor Starter Auxiliary Contact Bypass** - The auxiliary motor starter contact is bypassed

for this period after the time

shut down and a motor overload failure will be displayed. Likewise, if sometime after the delay, the auxiliary contact should open, the same failure screen display will be shown.

- **Oil Pressure Bypass at Compressor Start** - This timer bypasses the Low Oil Pressure Safety Limits. The timer starts when the compressor starts and anytime there is Lo Oil Pressure. This should be set as low as practical to prevent nuisance trips and provide a minimum operating time without adequate oil pressure.
- **Crankcase Oil Temperature Safety Changeover** - This timer allows Low Oil Crankcase Start Temperature safety setpoint to protect the compres-



## Compressor Timer Set Points

sor against cold oil during starting. After the timer has cycled, the Low Crankcase Run Temperature safety is then active.

- **Hi Discharge Temp Bypass @ Start** - This timer bypasses the Hi Discharge Temperature safety at start. The discharge temperature can rise quickly at compressor start, if the compressor had been running unloaded for long periods of time prior to shutdown.
- **After Power Failure (Auto Restart)** - This timer forces the control panel to wait for the set time period after a power failure before starting the compressor unit. By staggering the time settings, the compressors can be allowed to start automatically, one at a time, after a power failure. This prevents excessive loads on the power system that could be caused by all of the equipment coming online at the same time. The Power-up Auto Start operator option must be selected on the SETUP screen for this option to be active.
- **Filter Differential Pressure Safety Changeover** - This timer bypasses the Hi Run Filter Differential Pressure setting during start, to allow the Hi Start Filter Differential Pressure to protect against High Filter Differential during start. After the timer has cycled, The Hi Run Filter Differential Pressure safety is active.
- **True Anti-Recycle Timer** - Once the compressor turns off, this timer will keep the compressor off for the setting of the True Anti-Recycle Timer. This timer is used to prevent short cycling of the compressor.
- **Accumulative Anti-Recycle Timer** - This timer also forces a specified time between compressor starts. When the compressor starts, the timer resets and starts timing and accumulates running time. Once the compressor shuts down, it will not be allowed to restart for the remainder of time left on the Accumulative Anti-Recycle Timer. Unlike the True Anti-Recycle Timer, if the compressor has run for a time period that exceeds the setpoint of the Accumulative Anti-Recycle Timer, then when the compressor shuts down, it will be allowed to restart immediately.

The compressor restart options (Hot Starts or Anti-Recycle Timers) are selected from the **SETUP** screen (Figure 2), accessed from the Main Screen. One additional Anti-Recycle Timer is selected from the **SETUP** screen (Figure 2), which is the “Modified Anti-Recycle” timer.

- **Modified Anti-Recycle Timer** - This timer has no direct setpoint. It is defined as a combination of the True AntiRecycle Timer and the Accumulative AntiRecycle Timer. Normally when the “Modified AntiRecycle Timer” function is selected from the SETUP screen, the timer functions as a True Anti-Recycle timer and uses the setpoint of the True Anti-Recycle timer. However if the operator presses the stop button, or if a failure occurs, then the Modified AntiRecycle Timer function switches to activate the “Accumulative AntiRecycle Timer”. As the definition of the Accumulative Anti-Recycle Timer states, now the compressor will be allowed to restart when the present accumulated runtime and the present accumulated off time meets or exceeds the setting of the “Accumulative AntiRecycle Timer”.
- **Hot Starts/Hr Counter** - This counter counts compressor starts. After every start, a one-hour timer is reset and starts timing. If the timer times out, the hot starts counter is reset. When the counter reaches it’s preset value, it will not allow another compressor start until the one-hour timer times out and resets the counter. In other words, the hot starts counter will be reset when the time between compressor starts total one hour. This counter allows repetitive compressor starts, but once the counter has reached its set point, it requires a one-hour window between compressor starts in order for the counter to be reset.

## Shut Down Data

Captured Data at Shutdown			
Suction Press	40.0 psig	Suction Temp	50 °F
Discharge #1 Press	205.0 psig	Discharge #1 Temp	170 °F
Discharge #2 Press	205.0 psig	Discharge #2 Temp	120 °F
Filter In Press	205.0 psig	Oil Separator Temp	135 °F
Filter Out Press	135.0 psig	Process Temp	0 °F
Oil Manifold Press	0.0 psig	Chan 1 Temp	0 °F
Crankcase Press (Integral 2 stages)	0.0 psig	Chan 2 Temp	0 °F
Scrub Chan 1 Press	0.0 psig	Chan 3 Temp	0 °F
Run Oil Press Diff	5.0 psig		
Filter Press Diff	5.0 psig		
Ambience	80.0 psig		

[Back to Menu](#)

This screen views the captured data that was saved after shut-down.

## Miscellaneous Screens

**Condenser Control**

Back to Menu

Log On to Edit

Set

**Fan Control PID Parameters**

Proportional Gain

Reset Time

Rate Time

Manual Out

Fan On

Fan Off

**Condenser Pump Control**

Cooling On Pressure

Cooling Off Pressure

**Fan Speed Control Mode**

Automatic (PID)

Manual (% Full Speed)

**Fan Control PID Variables**

Discharge Pressure Setpoint

Actual Discharge Pressure

Fan Output (% full speed)

**Hot Gas Bypass Solenoid**

On @ % Capacity

Off @ % Capacity

This screen is designed for customized functions only, thus maybe placed as a view only screen.

**Note:** Changing variables on this screen will not have any effect unless you have a customized program for your unit.

To View if a customized program has been installed in your unit, go to the main screen and press VERSION, a screen will appear with the program version and the make model of the unit.



## Miscellaneous Screens

**Motor Speed Control**

Capacity Slide PID Tuning

Gain	0.0
Reset	0.0 min
Rate	0.0 min
Max Change Rate	0 %/min

VFD Motor PID Tuning

Gain	0.0
Reset	0.0 min
Rate	0.0 min
Max Change Rate	0 %/min

Back to Menu

Log On to Edit

Set

VFD Minimum Speed	0 %
Proc Var Lower Deadband	0.0 psid
Proc Var Upper Deadband	0.0 psid
Cap Slide Deadband	0 %
Unloading Rate	0 %/min

This screen is designed for customized functions only, thus maybe placed as a view only screen.

**Note:** Changing variables on this screen will not have any effect unless you have a customized program for your unit.

To View if a customized program has been installed in your unit, go to the main screen and press VERSION, a screen will appear with the program version and the make model of the unit.

## Vilter Only Screen

Vilter Manufacturing Emp. ONLY

**WARNING!** Settings on this screen should be used only by Vilter representatives or persons acting under their direction. Improper setting may require service not covered under warranty.

Calibrate Touch Screen

Raw Data Screen

Modbus Settings

System Date/Time

IP Address / Name

Screen Capture

Enabled

Disabled

Back to Menu

Target Volume Slide Location : 0%

**WARNING:** Settings on these screens should be used only by Vilter representatives or persons acting under their direction. Improper setting may result in loss of vital data and require service NOT covered under warranty.

## Diagnostics Force Output



*On/Off* – This will turn the force outputs option On/Off. The force outputs that can be modified are as follows: Main Motor Stater, Remote Alarm, Remote Trip, Load/Unload Solenoid #4, Load/Unload Solenoid #3, Load/Unload Solenoid #2, and Load/Unload Solenoid #1. You can choose the forced output by pressing the down arrow in the control labeled Available Outputs.

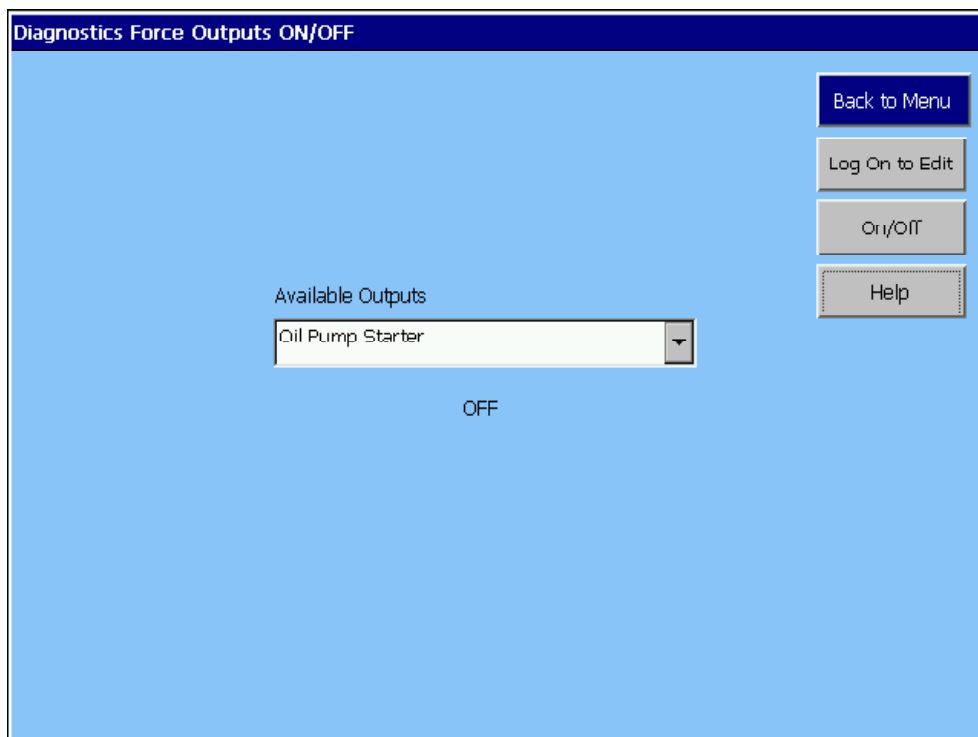



## Instrument Calibration

Instrument Calibration [Page 1 of 2]			
	mV Reading	Calibrated Value	New Value
Discharge Pressure Trans.	171.2 mV	142.1 "Hg	0.0 psig
Suction Pressure Trans.	293.1 mV	126.4 "Hg	0.0 psig
Oil Filter Outlet Pressure	2788.9 mV	95.7 psig	0.0 psig
Oil Filter Inlet Press. Trans.	4.3 mV	163.6 "Hg	0.0 psig
Discharge Temp. RTD	5037.9 mV	23.2 °F	0.0 °F
Suction Temperature RTD	5052.6 mV	24.6 °F	0.0 °F
Discharge Temp. RTD	5061.7 mV	25.4 °F	0.0 °F
Crankcase Oil Temp	5027.5 mV	22.2 °F	0.0 °F
Process Temperature RTD	5057.6 mV	25.0 °F	0.0 °F
Motor Amperage	1258.6 mV	31.5 amps	0.0 amps
Discharge Pressure Trans.	332.6 mV	121.4 "Hg	0.0 psig
Oil Man. Pressure Trans.	332.5 mV	121.3 "Hg	0.0 psig

The current values reflect the values presently maintained by the system. The user can perform a one-point calibration by entering the desired “new” value into the respective column. This will automatically adjust the “calibrated” value and the “new” value. The program will automatically adjust the calibration line to meet those values.

The following items can be calibrated at this screen: Discharge Pressure Transducer, Suction Pressure Transducer, , Oil Filter Outlet Pressure Transducer, Oil Filter Inlet Pressure Transducer, Discharge Temperature RTD, Suction Temperature RTD, Discharge Temp RTD #2 Crankcase Oil Temp, , Process Temperature RTD, Motor Amperage, Discharge Pressure Transducer #2 and Oil Manifold Pressure Transducer.

## Instrument Calibration

Instrument Calibration [Page 2 of 2]

	mV Reading	Calibrated Value	New Value
Spare RTD #1	5073.2 mV	26.5 °F	0.0 °F
Spare RTD #2	5074.1 mV	26.5 °F	0.0 °F
Spare RTD #3	5036.1 mV	23.0 °F	0.0 °F
Crankcase Pressure	0.0 mV	164.1 "Hg	0.0 psig
0-10 Volt Input #2	0.0 mV	0.0 psig	0.0 psig

Back

Back to Menu

Log On to Edit

Set

Help

Instrument calibration menu displays the Input channels that can be calibrated to represent the actual values at the sampling points.

The current values reflect the values presently maintained by the system. The user can perform a one point calibration by entering an offset value into the respective column. This will automatically adjust the current value and zero out the offset value.

The following items can be calibrated at this screen: three (3) spare RTDs and two (2) 0-10 volt input.

## Trend Chart

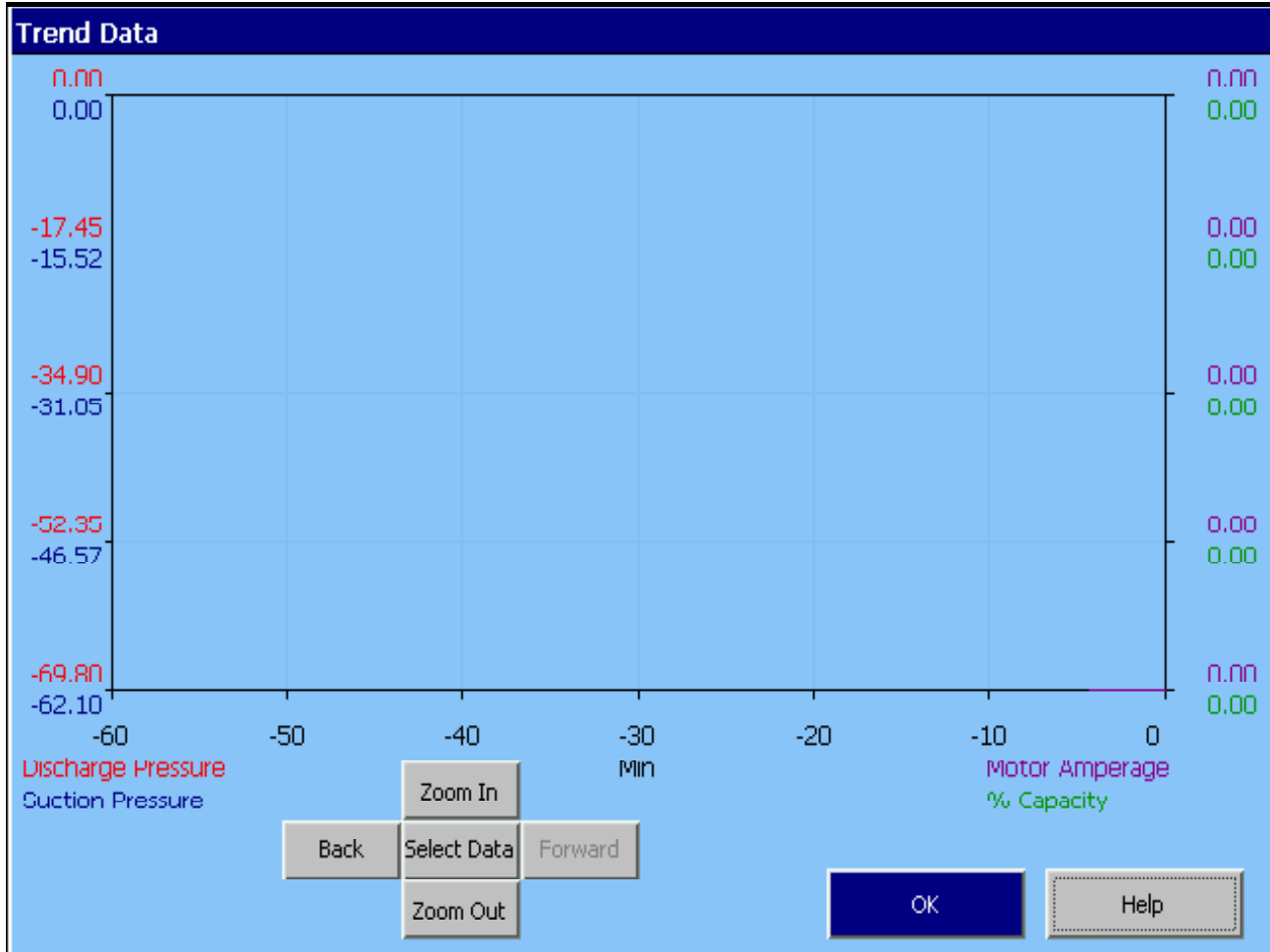

The trend analysis screen shows recorded data for problem analysis or tuning improvements. A logging buffer holds 120 hours worth of data for 11 variables sampled at 5 second intervals. When the trend chart screen is opened, logging continues for all variables (even those that are not displayed) and the chart is refreshed every 10 seconds. Once the 120 buffer is filled, the oldest samples are removed when new samples are recorded. Power cycling the panel will cause the buffers to be flushed.

Up to 4 variables can be selected for plotting at one time. Each is assigned one of 4 colors - the plotted trace and the vertical axis labels for a variable will be in its assigned color. The variables selected for plotting and the zoom level/plot region will be remembered until the panel is power cycled (at power up default settings are selected). When selecting new items to plot, be sure to recheck the color key at the bottom of the trend analysis screen (color assignments may have changed).

The vertical axis scaling and offset for each variable plotted is based on its range of values over the entire display buffer sample. This helps to magnify small changes in a variable and to keep one plot trace from falling on top of another, but it can be misleading. Look at the range of the vertical axis for a variable and try to visualize how far off screen the zero point would be.

## Data Select Screen

**Data Selection**

OK

<input type="checkbox"/> Suction Temperature RTD	<input checked="" type="checkbox"/> Suction Pressure
<input type="checkbox"/> Discharge Temp. RTD	<input checked="" type="checkbox"/> Discharge Pressure
<input type="checkbox"/> Oil Separator Temp. RTD	<input type="checkbox"/> Oil Injection Pressure
<input type="checkbox"/> Process Temperature	<input checked="" type="checkbox"/> % Capacity
<input checked="" type="checkbox"/> Motor Amperage	<input type="checkbox"/> Oil Filter
<input type="checkbox"/> % Volume	

**Max of 4 items plotted at once. You must uncheck something before you can select more items.**

The user has the ability to select which value they would like to see displayed on the graph by pressing the Data Select button.

## Event List

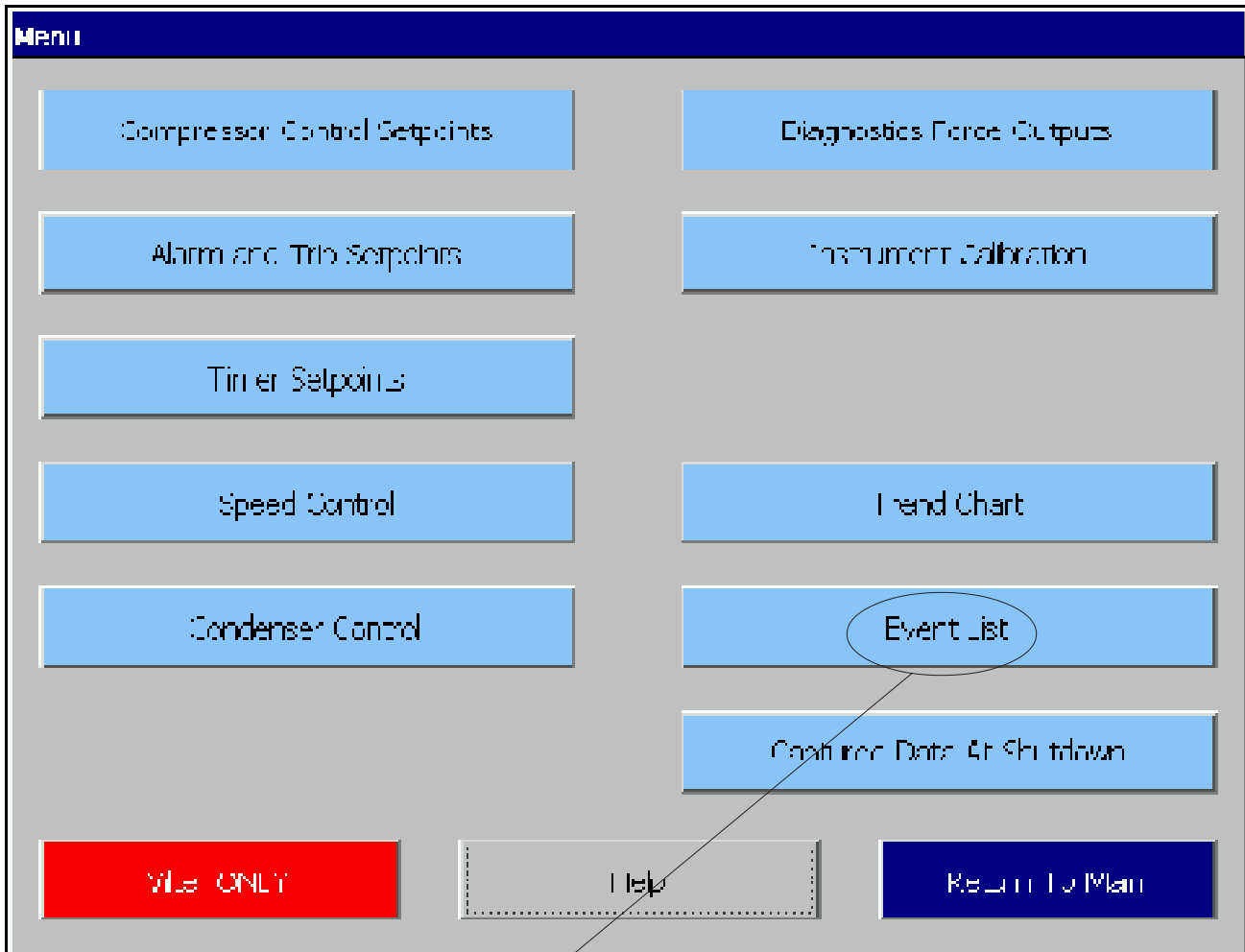

Touch Here

From the **Menu** screen, touch the Event List button. The screen on the next page will appear.



## Event List

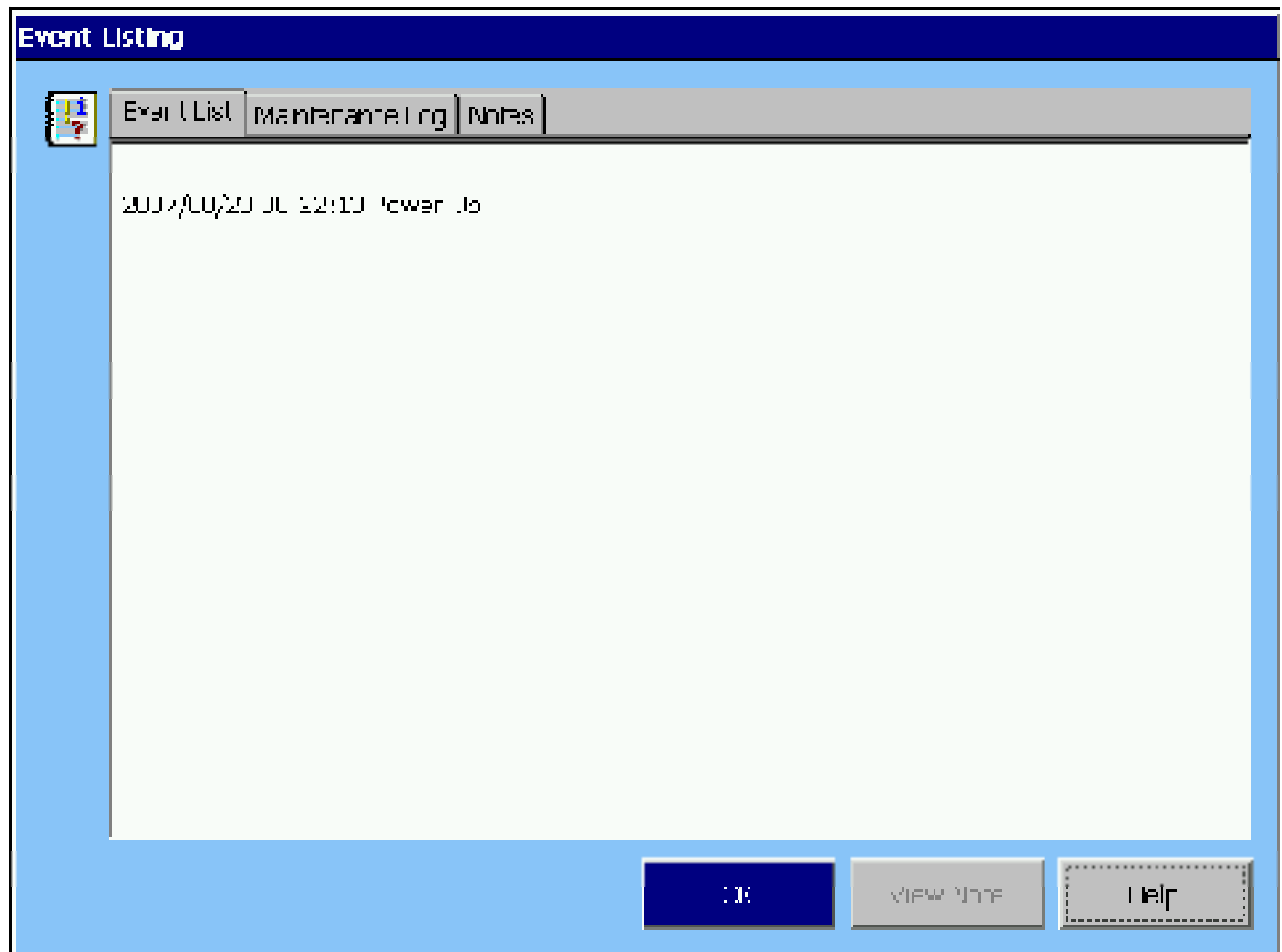

The Event List will give a chronological record of the last 40 events recorded by the controller. These events can be filtered by selecting the Filter box on the upper left of the screen.



## Trouble Shooting Flowchart Vantage Only

*MicroController does not boot up, no lights on any boards.*

Check to make sure 120VAC is run to "L1" on the combination relay and analog board. This is the board on the inside back of the panel. "L1" is the fifth connector down from the top and the 9th terminal down. The neutral should be brought to any "N" on the relay board.

Check F11 fuse on combination relay and analog board.

Check F1 fuse on the power supply, located on the inside top of panel. If all of the above is okay, the power supply may be bad. Check DC voltages on the single board computer interface board, which is the big green board on the door. Along the right edge of this board, just above the power supply connector J14, are test points. If proper voltages are not located at these test points, the power supply may be faulty.

*MicroController appears to be booted, lights seen on boards and E-stop switch, but no touch screen is evident.*

Check cable connections located on the LCD Inverter board. This board is located inside the door on the LCD touch screen back plane above the single board computer. The connector with the pink and white wires, located on the left center of the board is the power supply to the board. The connector on the top right of the board with the black wires has the data wires. If these are inserted correctly, the problem could be bad solder joint on the LCD Inverter board or a component failure.

*MicroController boots up but all data temperatures and pressures are zeroed and do not update.*

Check combination relay and analog board jumpers J2 & J4. They should be on pins 1 & 2 (center and right pins).

Check the DIP switch (S1) on the combination relay and analog board. This identifies the node address of the combination relay and analog board. Only switch #1 should be on, the rest off.

The MicroController has (2) boards running separate programs. The combination relay and analog board located inside the panel on the back right calculates pressures, temperatures, amps and monitors inputs. The single board computer requests this data for action and display. The single board computer will instruct the combination relay and analog board to activate outputs or relays as needed. Communication between the boards is RS-485 running at 115200 baud. The cable is basically phone cable with phone jack style connectors. The connector to the single board computer is on the touch screen back panel and is labeled RS 485 Com2 to Analog Bd. The connector on the combination relay and analog board is located on the bottom of the board. There are 2 connectors on the combination relay and analog board, either one can be used.

If this cable is open or disconnected, there will be no communications between the boards. The top two green lights on the combination relay and analog board (D9 & D10), located on the center of the board, will be off. The pressures and temperatures will not update. Ensure the cable is plugged in correctly. Try rebooting again. If the problem persists, try moving the cable on the combination relay and analog board to the other connector. If not successful, try a different cable on the combination relay and analog board to the other connector on the board. If not successful, try a different cable. Any phone style cord should work. If neither of these help, contact the Vilter Home Office.



## Trouble Shooting Flowchart Vantage Only

*A bank of pressure or temperature channels no longer function.*

There are eight fuses on the combination relay and analog board that limit the current on the 24VDC to the Analog channels. The fuses are 500 milliamp, located near the power supply connectors and brown in color. LEDs next to the fuses give a visual indication of the status of the fuse, however, it is best to pull the fuse and check them with an ohmmeter. If any are blown, find the shorted device that is responsible for the blown fuse and replace.

F1, F6 & F7 protects the +24VDC supply to the pressure transducers and relays.

F2 protects the +5VDC supply for analog channels P6&P7.

F4&F5 protects the -12VDC and +12VDC supply respectively, which is subregulated to +5VDC, required for multiplexers, ana-log to digital converters, and temperature channel.

F3 & F8 protects the main +5VDC supply required for most of the components on the combination relay and analog board.

If F1, F6 & F7 blows, the pressure transducers will produce erroneous readings and the relays on the relay board combination relay and analog board will drop out (de-energize). If F3, F4 or F5 blows, all analog readings will be affected.

*A pressure channel reads a negative number over -140*

This indicates the transducer wiring or transducer is either open or shorted. Check wiring to print. Check all fuses.

*A temperature channel reads a large negative value over -400°*

This indicates the RTD wiring or RTD is open. Check wiring to print. Check all fuses.



## Safety Failure Message

### VMC Safety Failure Messages

- Suction Pressure SP#1 Fail - This message will appear when the suction pressure falls below the safety setting of the Lo Suction Pressure Trip Setpoint No.1. In addition, this message will appear when the suction pressure reading rises above 300 PSI, indicating an open transducer or bad analog channel.
- Suction Pressure SP#2 Fail - This message will appear when the suction pressure falls below the safety setting of the Lo Suction Pressure Trip Setpoint No.2. In addition, this message will appear when the suction pressure reading rises above 300 PSI, indicating an open transducer.
- Discharge Pressure SP#1 Fail – This message will appear when the discharge pressure exceeds the safety setting of the Hi Dsch Press Trip Setpoint No. 1 . In addition, this message will appear when the discharge pressure reading falls below 30” Hg, indicating a shorted transducer.
- Discharge Pressure SP#2 Fail – This message will appear when the discharge pressure exceeds the safety setting of the Hi Dsch Press Trip Setpoint No. 2 . In addition, this message will appear when the discharge pressure reading falls below 30” Hg, indicating a shorted transducer.
- Discharge Pressure#2 SP#1 Fail – This message will appear when the discharge #2 pressure exceeds the safety setting of the Hi Dsch #2 Press Trip Setpoint No. 1 . In addition, this message will appear when the discharge pressure reading falls below 30” Hg, indicating a shorted transducer. This message will only appear if the compressor is a 12 or 16 cylinder compressor.
- Discharge Pressure#2 SP#2 Fail – This message will appear when the discharge #2 pressure exceeds the safety setting of the Hi Dsch #2 Press Trip Setpoint No. 2 . In addition, this message will appear when the discharge pressure reading falls below 30” Hg, indicating a shorted transducer. This message will only appear if the compressor is a 12 or 16 cylinder compressor.
- Lo Control Temperature Fail – This message will appear when the Process Control Temperature falls below the safety setting of the Lo Control Temperature Trip Setpoint. In addition, this message will appear when the Process Control Temperature rises above 300 degrees F, indicating an open RTD.
- Suction Temp Fail – This message will appear when the suction temperature falls below the safety setting of the Low Suction Temperature Trip setpoint. In addition, this message will appear when the suction temperature rises above 400 degrees, indicating an open RTD.



## Safety Failure Message

- Discharge #1Temp Fail – This message will appear when the discharge #1 temperature rises above the safety setting of the High Discharge Temperature Trip setpoint. In addition, this message will appear when the discharge temperature falls below -30 degrees, indicating a shorted RTD.
- Discharge #2 Temp Fail – This message will appear when the discharge #2 temperature rises above the safety setting of the High Discharge Temperature Trip setpoint. In addition, this message will appear when the discharge temperature falls below -30 degrees, indicating a shorted RTD. This message will only appear if the compressor is a 12 or 16 cylinder compressor.
- Oil Crankcase Start Temp Fail – This message will appear when the Oil Crankcase Temp is below the Low Oil Crankcase Start Temp Trip setpoint. In addition this message will appear after the Oil Crankcase Temp Safety Changeover timer times out and the Oil Crankcase temperature fails to rise above the Low Oil Crankcase Start Temp Reset after the compressor is started.
- Oil Crankcase Run Temp Fail – This message will appear when the Oil Crankcase Temp is below the Low Oil Crankcase Run Temp Reset setpoint after the Oil Crankcase Temp Safety Changeover timer times out.
- Hi Oil Run Temp Fail – This message will appear when the Oil Crankcase temperature rises above the High Crankcase Oil Temperature trip setpoint.
- Manifold Pressure Fail – This message will appear with the manifold pressure rises above 300 PSI or falls below 30” Hg.
- Lo Run Oil Pressure Fail – This message will appear with the Run Oil Pressure (Manifold minus Suction) has remained below the Low Oil Pressure Reset setpoint when the Oil Pressure Bypass at Compressor Start timer times out. This message will also appear when the Run Oil Pressure falls below the Low Oil Pressure trip setpoint after the Oil Pressure Bypass at Compressor Start timer times out.
- Filter Inlet Pressure Fail – This message will appear with the filter inlet pressure rises above 300 PSI or falls below 30” Hg.
- Filter Outlet Pressure Fail – This message will appear with the filter outlet pressure rises above 300 PSI or falls below 30” Hg.
- Start Filter Diff Press Fail – This message will appear if the Filter Differential pressure rises above the High Fltr Diff Press – Start setpoint before the Filter Differential Pressure Safety Changeover timer times out.



## Safety Failure Message

- Run Filter Diff Press Fail – This message will appear if the Filter Differential pressure rises above the High Fltr Diff Press – Run setpoint after the Filter Differential Pressure Safety Changeover timer times out.
- Motor Starter Aux Contact Fail – This message will appear if the Motor Auxiliary contact fails to close before the Compressor Starter Auxiliary Contact Bypass timer times out. Refer to wiring diagram.
- Auxiliary Safety#1 Input Fail – This message will appear when power is removed from the input module that is designated as “Auxiliary #1 Safety” (please refer to your wiring diagram).



**Note Page**

## Flash Card Installation Instructions

**Note: Before Powering Down To Replace Flashcard, You Must Copy Down All Setpoints As These Will Need To Be Re-entered When New Flashcard Is Installed.**

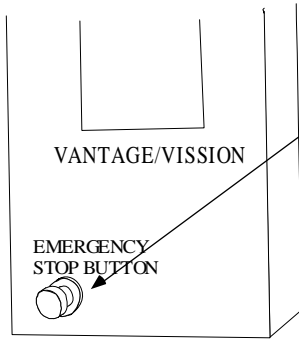

Hit The Emergency Stop Button Located In Front Of The Panel



Verify Unit is Shut Down Completely



Verify Lockout Disconnect On Compressor Start. This Ensures Compressor Does Not Start.

Proceed As Follows

Disconnect the Connector And Ribbon As Shown

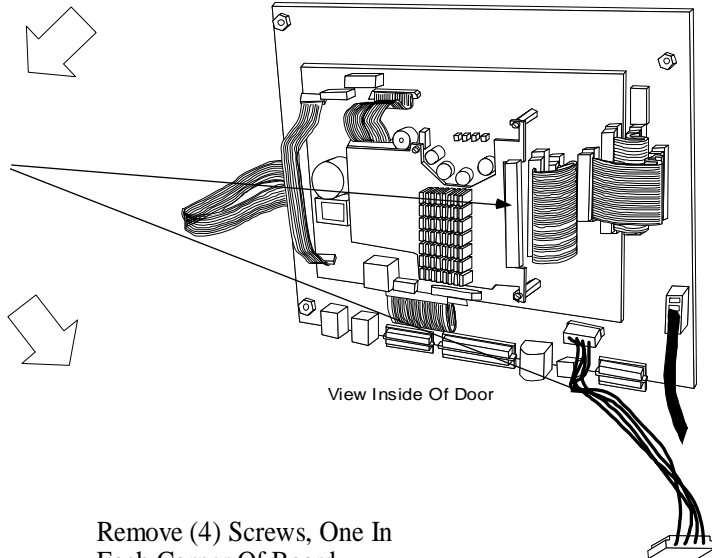

Remove (4) Screws, One In Each Corner Of Board

Flip Board Over To View Flash Card

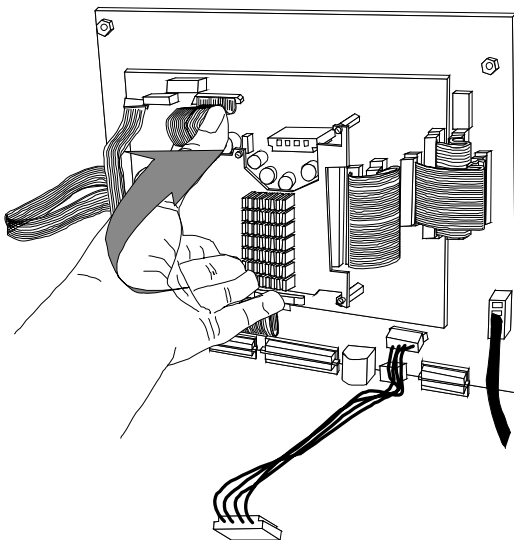



## Flash Card Installation Instructions

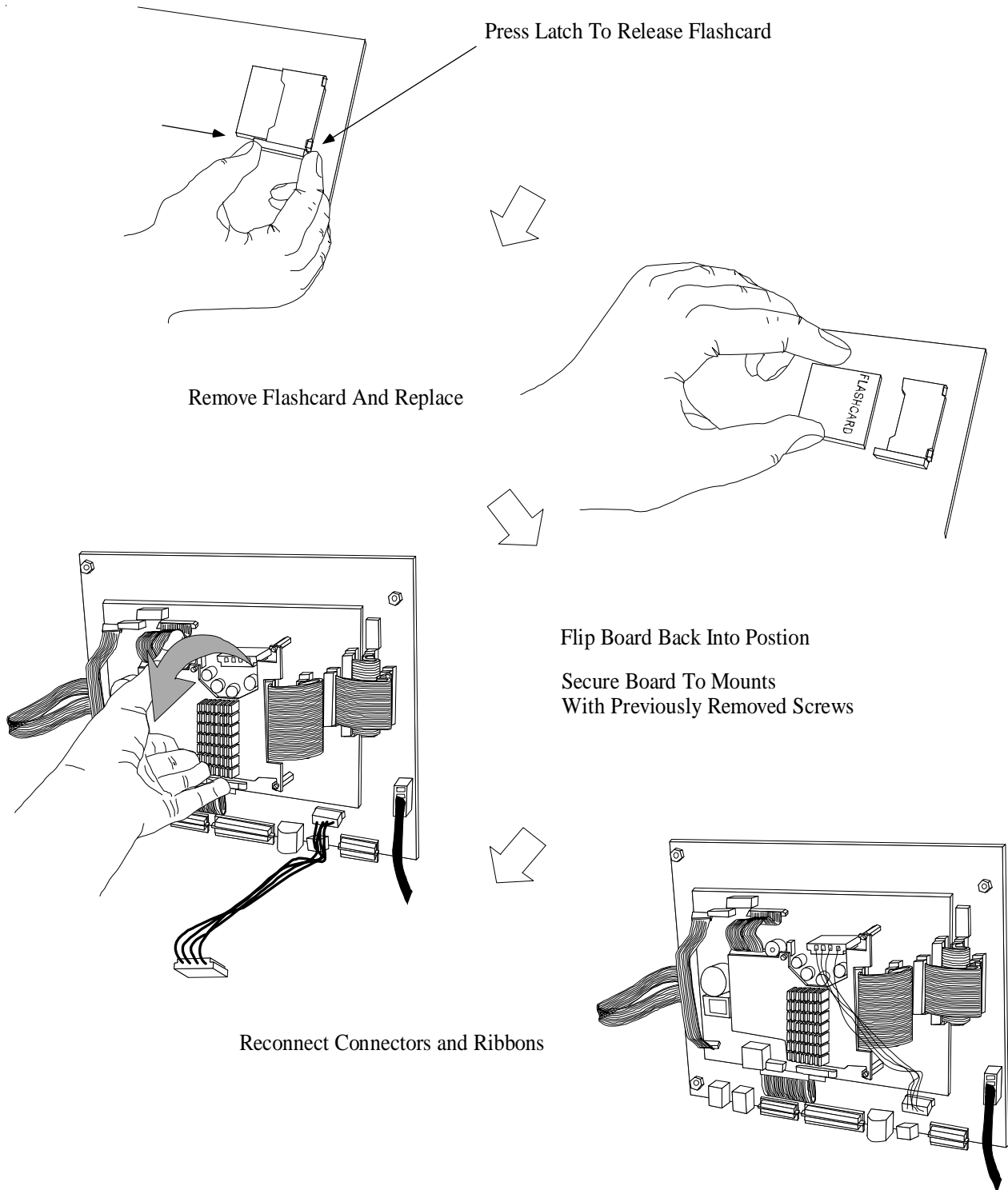

**Note:** You Must Re-enter Setpoints And Recalibrate Slide Valves.  
See Section On Setpoint Values And the Section On Optical Actuators.

## Back Light Installation Instructions

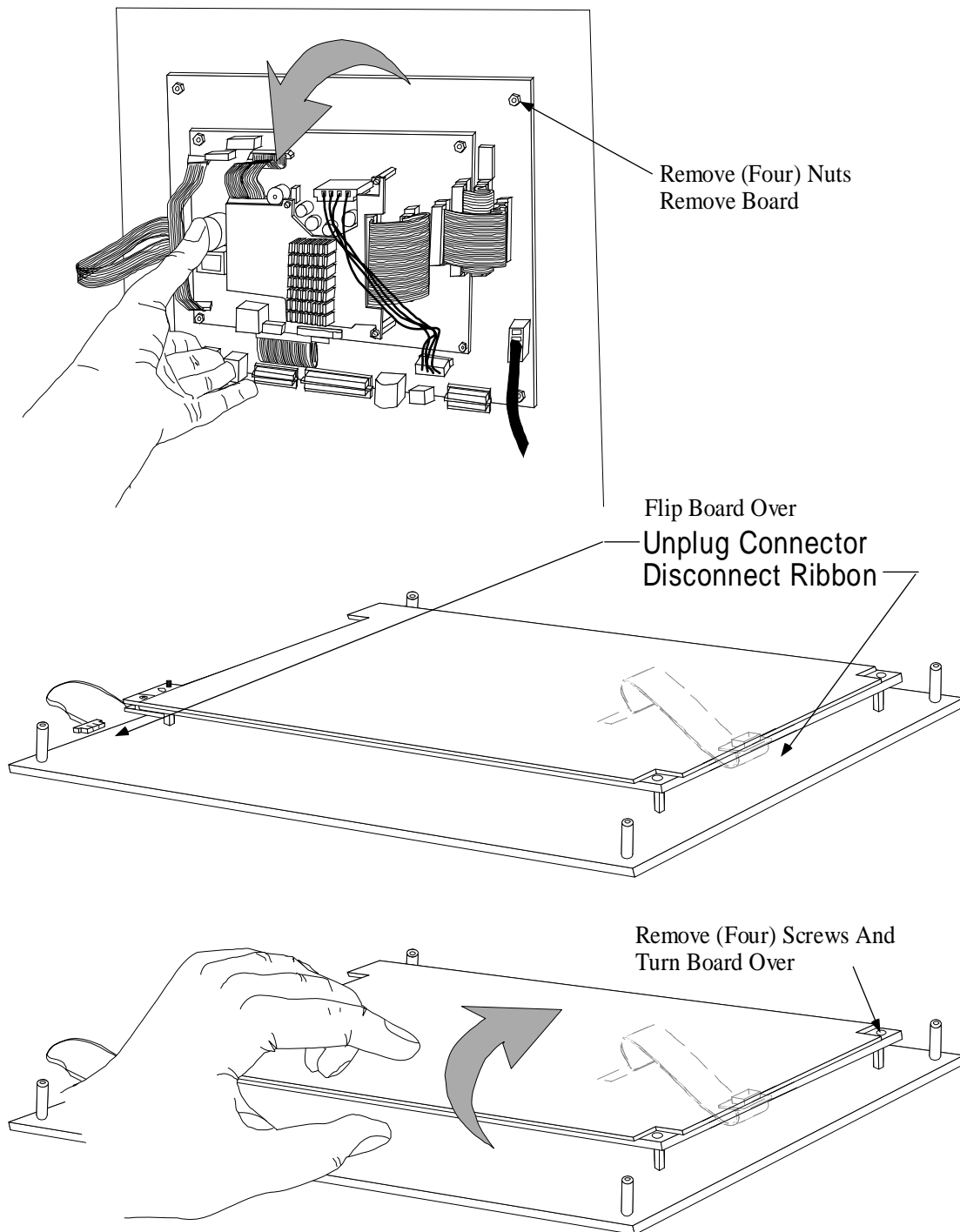

## Back Light Installation Instructions

Remove Small Screw  
And Slide Back Light  
Out As Shown

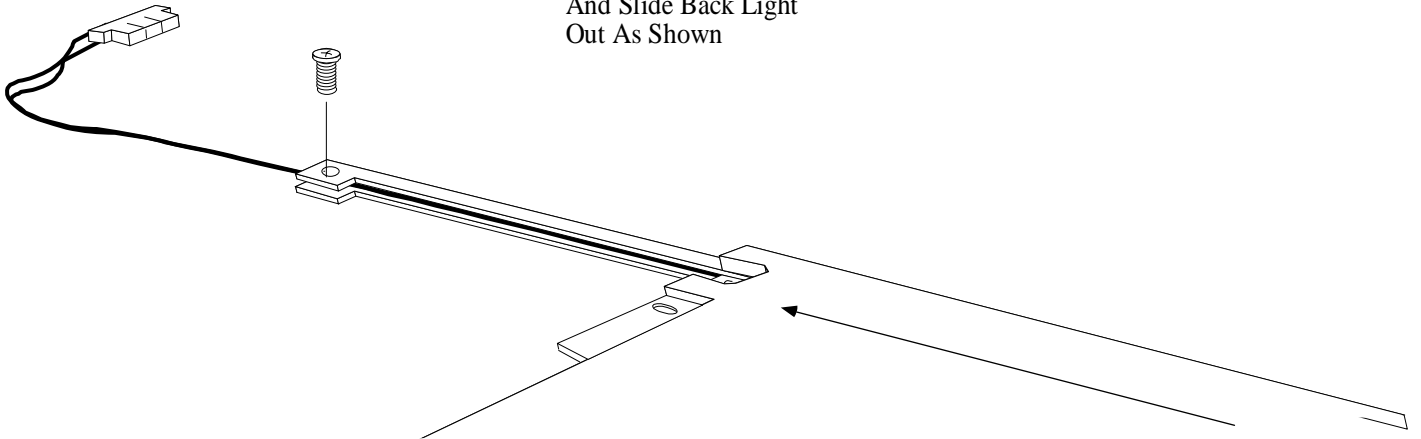

Slide New Back Light In And  
Secure With Previously Removed Screw

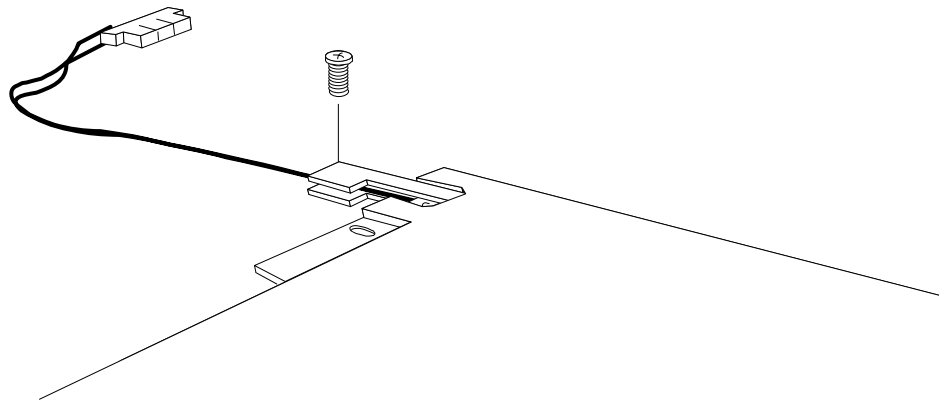

## Back Light Installation Instructions

Place Board Back Into Position And Secure

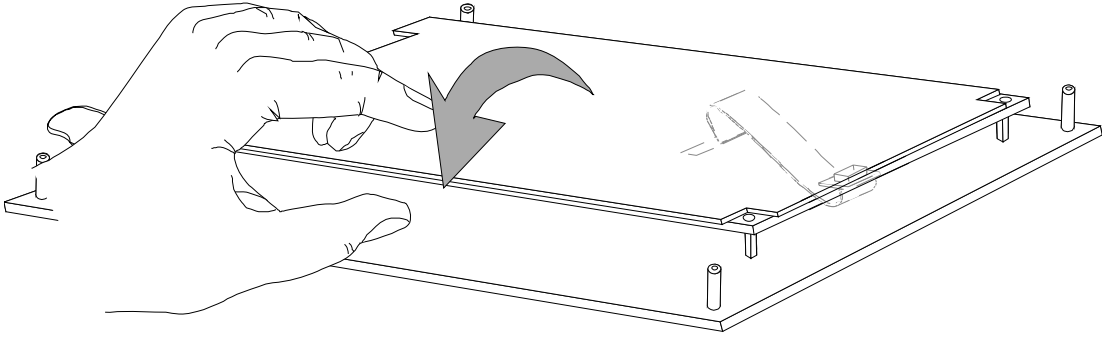

Connect Ribbon And Plug  
Connector Back In

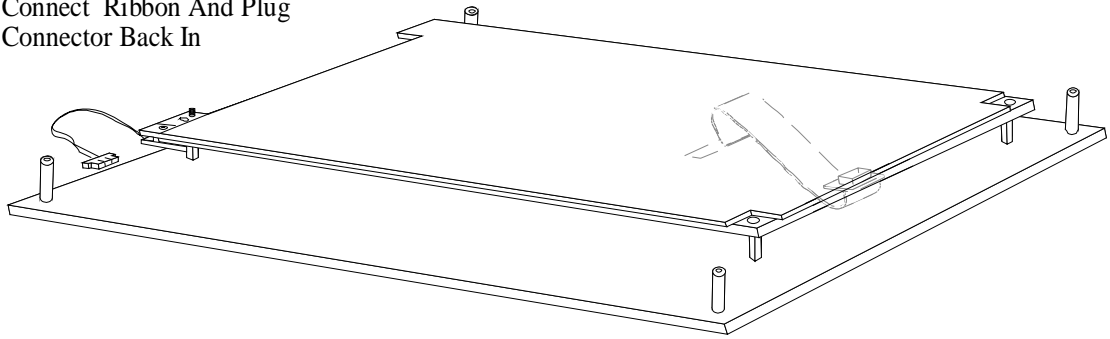

Place Board Back Onto Back Of Panel And  
Secure With Previously Removed Nuts

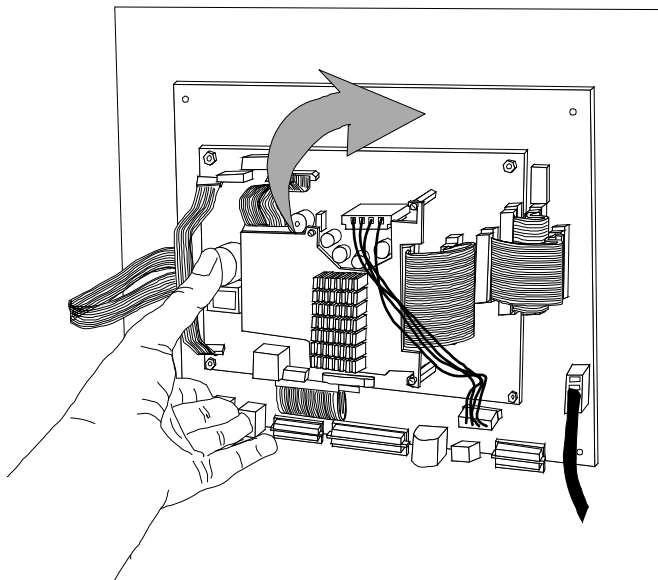

## **System Setpoints Alarms and Trip**

COMPRESSOR ALARM and TRIP SETPOINTS (page 1 of 2) *Default*

	Alarm	Trip	Reset	
<b>Low Suction Pressure</b>				
Setpoint No.1	3"	4"	2"	
Setpoint No.2	1"	2"	0"	
<b>High Discharge Pressure</b>				
Setpoint No.1	200	210	195	
Setpoint No.2	220	230	215	
<b>High Discharge #2 Pressure</b>				
Setpoint No.1	200	210	195	
Setpoint No.2	220	230	215	
Low Suction Temperature	-45	-50	-40	°F
High Discharge Temperature #1	295	300	290	°F
Low Crankcase Oil Temp- Start-	75	70	80	°F
Low Crankcase Oil Temp-Run	105	100	110	°F
<b>High Discharge Temperature #2</b>	<b>295</b>	<b>300</b>	<b>290</b>	<b>°F</b>
Low Control Temperature	-50	-55	-45	°F
High Control Temperature	100	---	95	°F

COMPRESSOR ALARM and TRIP SETPOINTS (page 2 of 2)

	Alarm	Trip	Reset	
High Oil Crankcase Temp	130	135	125	°F
(1) Low Oil Pressure	30	25	32	psid
High Fltr. Diff.Press.-Start	38	40	25	psid
High Fltr. Diff.Press.-Run	12	15	10	psid

This setting is visible and adjustable in software prior to January 2006.  
 (1) 300 Series settings are:      40                      35                      42                      psid

LEVEL 1 COMPRESSOR SETPOINTS (Suction Pressure Control) (page 1 of 2) *Default*

Compressor Start/Stop	On	Off	
Setpoint No.1	20	6	Hg/psig
Setpoint No.2	15	11	Hg/psig
Compressor Control Setpoints			
Setpoint No.1	20		Hg/psig
Setpoint No.2	24		Hg/psig
Load Deadband			
Setpoint No.1	2.00		psi
Setpoint No.2	2.00		psi
Unload Deadband			
Setpoint No.1	2.00		psi
Setpoint No.2	2.00		psi
Load Timer Interval	20 sec	Unload Timer Interval	10 sec

LEVEL 1 COMPRESSOR SETPOINTS (Temperature Control) Note: Only accessible if selected from set-up

Compressor Start/Stop	On	Off	
Setpoint No.1	20	10	°F
Setpoint No.2	25	15	°F
Compressor Control Setpoints			
Setpoint No.1	25.0		°F
Setpoint No.2	30.0		°F
Load Deadband			
Setpoint No.1	2.00		°F
Setpoint No.2	2.00		°F
Unload Deadband			
Setpoint No.1	2.00		°F
Setpoint No.2	2.00		°F
Load Timer Interval	20 sec	Unload Timer Interval	10 sec

LEVEL 1 ADDITIONAL COMPRESSOR SETPOINTS (page 2 of 2)

High Suction Pressure Unload	On	Off	
(1) Step #1	85	84	psig
High Discharge Pressure Unload			
(1) Step #1	208	206	psig
Current Transformer Ratio		250	amps

(1) Note: There will be a setting for each step of unloading.

COMPRESSOR TIMER SETPOINTS *Default*

	Default Values	
Unloaded Start	15	sec
Max Time @ Min Capacity	30	min
Compressor Start Aux. Contact Bypass	10	sec
Oil Pressure Bypass at Compressor Start	10	sec
Crankcase Oil Temp Safety Changeover	60	sec
High Discharge Temp Bypass@ Start	255	sec
Auto Restart After Power Failure	5	min
Filter Diff. Pressure Safety Changeover	60	sec
True Anti Recycle Timer	20	min
Accumulative Anti Recycle Timer	20	min
(1) Number of Hot Starts per Hour	3	counts

(1) Refer to the Motor Data Sheet for maximum starts.





5555 S. Packard Ave.  
Cudahy, WI. 53110

## Engineering Data Sheets

### Reciprocating Setpoint Default Values/Limits

Date: December 19th, 2005

T 00468 -4 Rev: 0

Written By: RK

Revised By: CH

Approved By: WW

#### SET Up Screen- Options Menu- *Default*

Operator Name <input style="width: 100%;" type="text" value="Sample"/>	<input type="button" value="Add Operator"/>  <input type="button" value="Delete Operator"/>	Language <input style="width: 100%;" type="text" value="English"/>  Units <table style="width: 100%; border: none;"> <tr> <td style="width: 50%; text-align: center;">Pressure <input style="width: 100%;" type="text" value="psig"/></td> <td style="width: 50%; text-align: center;">Temperature <input style="width: 100%;" type="text" value="Fahrenheit"/></td> </tr> </table>	Pressure <input style="width: 100%;" type="text" value="psig"/>	Temperature <input style="width: 100%;" type="text" value="Fahrenheit"/>
Pressure <input style="width: 100%;" type="text" value="psig"/>	Temperature <input style="width: 100%;" type="text" value="Fahrenheit"/>			
After Power Failure <input type="radio"/> Auto Restart <input checked="" type="radio"/> Manual Restart	Bypass Compressor On/Off Control <input type="radio"/> Enable <input checked="" type="radio"/> Disable	Refrigerant <input style="width: 100%;" type="text" value="R-717 ammonia"/>		
2-8 cyl or 12&16 cyl <input type="radio"/> 2-8 <input checked="" type="radio"/> 12&16 cylinder	Anti -Recycles <input style="width: 100%;" type="text" value="Hot Starts"/>			
Setpoint#1/#2 Select <input type="radio"/> Force Setpoint #2 <input checked="" type="radio"/> Normal	Max Time @ Min Capacity <input type="radio"/> Enable <input checked="" type="radio"/> Disable	Compressor Control VIA <input checked="" type="radio"/> Suction Pressure <input type="radio"/> Process Temperature <input type="radio"/> Discharge Pressure		
Modbus Slave Net Addr <input style="width: 100%;" type="text" value="5"/>				

Indicates selected default.

COMPRESSOR ALARM and TRIP SETPOINTS (page 1 of 2) **Limits**

	Alarm	Trip	Reset
Low Suction Pressure _____			
Setpoint No.1	30"/300	30"/300	30"/300
Setpoint No.2	30"/300	30"/300	30"/300
High Discharge Pressure _____			
Setpoint No.1	30"/350	30"/350	30"/350
Setpoint No.2	30"/350	30"/350	30"/350
High Discharge #2 Pressure _____			
Setpoint No.1	30"/350	30"/350	30"/350
Setpoint No.2	30"/350	30"/350	30"/350
Low Suction Temperature	-99/300	-99/300	-99/300 °F
High Discharge Temperature #1	-30/325	-30/325	-30/325 °F
Low Crankcase Oil Temp- Start-	60/200	60/200	60/200 °F
Low Crankcase Oil Temp-Run	60/200	60/200	60/200 °F
High Discharge Temperature #2	-30/325	-30/325	-30/325 °F
Low Control Temperature	-99/210	-99/210	-99/210 °F
High Control Temperature	-99/210	---	--- °F

COMPRESSOR ALARM and TRIP SETPOINTS (page 2 of 2) **Limits**

	Alarm	Trip	Reset
High Oil Crankcase Temp	0/160	0/160	0/160 °F
Low Oil Pressure	15/50	15/50	15/50 psid
High Fltr. Diff.Press.-Start	0/40	0/40	0/40 psid
High Fltr. Diff.Press.-Run	0/40	0/40	0/40 psid

This setting is visible and adjustable in software prior to January 2006.

LEVEL 1 COMPRESSOR SETPOINTS (Suction Pressure Control) (page 1 of 1) **Limits**

	On	Off	
Compressor Start/Stop			
Setpoint No.1	30"/150	30"/150	Hg/psig
Setpoint No.2	30"/150	30"/150	Hg/psig
Compressor Control Setpoints			
Setpoint No.1	30"/150	30"/150	Hg/psig
Setpoint No.2	30"/150	30"/150	Hg/psig
Load Deadband			
Setpoint No.1	.1/150	.1/150	psi
Setpoint No.2	.1/150	.1/150	psi
Unload Deadband			
Setpoint No.1	.1/150	.1/150	psi
Setpoint No.2	.1/150	.1/150	psi
Load Timer Interval	0/600 sec	Unload Timer Interval	0/600 sec

LEVEL 1 COMPRESSOR SETPOINTS (Temperature Control) **Limits Note: Only accessible if selected from set-up**

	On	Off	
Compressor Start/Stop			
Setpoint No.1	-99/300	-99/300	°F
Setpoint No.2	-99/300	-99/300	°F
Compressor Control Setpoints			
Setpoint No.1	-99/300	-99/300	°F
Setpoint No.2	-99/300	-99/300	°F
Load Deadband			
Setpoint No.1	.1/300	.1/300	°F
Setpoint No.2	.1/300	.1/300	°F
Unload Deadband			
Setpoint No.1	.1/300	.1/300	°F
Setpoint No.2	.1/300	.1/300	°F
Load Timer Interval	0/600 sec	Unload Timer Interval	0/600 sec

LEVEL 1 ADDITIONAL COMPRESSOR SETPOINTS (page 2 of 2)

	On	Off
High Suction Pressure Unload		
Step #1	30"/250	30"/250 Hg/psig
High Discharge Pressure Unload		
Step #1	30"/250	30"/250 Hg/psig
Current Transformer Ratio	100-1000 amps	



5555 S. Packard Ave.  
Cudahy, WI. 53110

**Engineering Data Sheets**  
**Reciprocating Setpoint Default Values/Limits**

Date: December 19th, 2005

T 00468 -7 Rev: 0

Written By: RK

Revised By: CH

Approved By: WW

COMPRESSOR TIMER SETPOINTS **Limits**

	Values	
Unloaded Start	0/999	sec
Max Time @ Min Capacity	0/60	min
Compressor Start Aux. Contact Bypass	5/60	sec
Oil Pressure Bypass at Compressor Start	0/60	sec
Crankcase Oil Temp Safety Changeover	0/90	sec
High Discharge Temp Bypass@ Start	5/120	sec
Auto Restart after Power Failure	1/120	min
Filter Diff. Pressure Safety Changeover	0/600	sec
True Anti Recycle Timer	6/60	min
Accumulative Anti Recycle Timer	6/60	min
Number of Hot Starts per Hour	1/10	counts





## Modifications for Analog Board in Vission/Vantage after July 2003

### Using Danfoss Transducers with 2783J qualified boards

The analog boards used in the Vission and Vantage panels after July 2003 have been modified to accommodate the use of Danfoss transducers (VPN 2783J). These analog boards are denoted as “2783J qualified” boards. The use of 2783J qualified boards with Danfoss transducers require that scaling factors for the Danfoss pressure transducers be checked and modified if necessary.

The scale factors for all transducers are located at a specific Index location in Vission/Vantage database. Refer to Figure 1. This table shows the proper scale factors for each type of transducer as well as the Index location of the scaling factor for each transducer.

Vission and Vantage (VSS and SOI units)			Vission (VRS units)		
<b>Transducer</b>	<b>Index</b>	<b>Value*</b>	<b>Transducer</b>	<b>Index</b>	<b>Value*</b>
Suction	N658	3950	Suction	N658	3950
Discharge	N659	3950	Discharge	N659	3950
Man/Filter Out	N660	3950	Manifold	N660	3950
Filter In	N661	3950	Filter Inlet	N661	3950
			Filter Outlet (Retrofit)	N664	3950
Vission and Vantage (Cool Compression units)			Vantage (Recip)		
<b>Transducer</b>	<b>Index</b>	<b>Value*</b>	<b>Transducer</b>	<b>Index</b>	<b>Value*</b>
Suction	N658	3950	Suction	N658	3950
Discharge	N659	3950	Discharge#1	N659	3950
Man/Filter Out	N660	3950	Filter Out	N660	3950
			Filter Inlet	N661	3950
			Discharge#2	N662	3950
			Oil Manifold	N663	3950
			Crankcase	N664	3950

**Figure 1. Transducer Index Table and Scale Factors**

Value\* : The value 3950 shown is the Scale Factor for transducers manufactured by Ametek and Setra. This does NOT include Danfoss transducers. **If Danfoss transducers are being used with 2783J qualified boards, the “Value” at the Indexes shown above needs to be modified to 4297.** The procedure on the next page describes how to modify the scaling factor.



## Modifications for Analog Board in Vission/Vantage after July 2003

### The procedure to Change Scale Factors on 2783J Qualified Board

1. From the Main Screen, press the Menu button.
2. From the Menu Screen, press the Vilter ONLY screen.
3. Logon
4. From the Vilter ONLY screen, press the Raw Data Screen button.  
You will now see a screen labeled "Data Test", containing 4 columns, 2 labeled "Index" and 2 labeled "Value".
5. Press the "Set" button and then press one of the blank boxes under either one of the Index columns.
6. A keypad will be displayed. Now type in "N658" (without the quote marks). Press the OK button. (Per the table, this is the Index for the Suction Pressure transducer.)
7. You are now returned to the "Data Test" screen. You will see "N658" in the box that you touched, and you will see the value 3950 in the corresponding "Value" box. This is the scale factor that will be changed.
8. Now press the "Set" button again, and press the "Value" box that contains the value 3950.

- A numeric keypad will now be visible.
9. Press the Clear button. Now press the buttons 4297, followed by pressing the "Enter" button. You will now be returned to the "Data Test" screen, and the Value field that previously contained 3950 now contains the Value 4297. Per the table below, you have now corrected the scaling factor for the Suction Pressure transducer.
  10. Continue this process, entering in "Index" values and changing the scaling factors for all transducers. (Reference Figure 1 below.)
  11. When completed, press the OK button and return back to the main screen.
  12. Now go to the LOGON screen and perform a "BACKUP SETTINGS". After a minute or so, the new scale factors will be "active".
  13. You may now need to recalibrate your transducers again, as the new scale factors will affect the current readings of the transducers. If you have gauges on your system, you can do this using your gauge readings. When you have completed re-calibration of all your transducers, do another "BACKUP SETTINGS".

	2895A	3011A Vission	3011C1 Vantage	3011A Vission (2783J qualified)	3011C1 Vantage (2783J qualified)
Ametek	Yes	Yes	Yes	Yes	Yes
Danfoss	No*	No	No	Yes-Rescale	Yes-Rescale
Setra	Yes	Yes	Yes	Yes	Yes

**Table II The acceptable mix of analog boards and transducers.**

No\* = this combination of board and transducer will result in a very slight scaling error (2 percent error over entire 0-300 PSIG range of transducer). Vilter does not recommend using the Danfoss transducer with a 2895A board.



If service is required, first contact your equipment distributor or contact  
A Vilter Technical Service Representative at:

Vilter Manufacturing Corporation  
5555 South Packard Ave.  
PO Box 8904  
Cudahy, WI 53110-8904  
Telephone: 414-744-0111  
Fax: 414-744-1769  
e-mail: [service@vilter.com](mailto:service@vilter.com)

**Note:** It will be necessary to have your Vilter order number available  
when contacting Vilter Manufacturing Corporation for service support.

*Disclaimer: Specifications are subject to change without notification.*







Vilter Manufacturing Corporation  
5555 South Packard Ave.  
PO Box 8904  
Cudahy, WI 53110-8904  
Telephone: 414-744-0111  
Fax: 414-744-1769  
e-mail: [service@vilter.com](mailto:service@vilter.com)