

Case Controller 200 (CC200) and Case Display

Firmware 1.03F01 Installation and Operation Manual



CC200 FIRMWARE VERSION 1.03F01



The enclosure should never be opened. Warranty void of seal is tampered with or removed.

FCC COMPLIANCE NOTICE

The CC200 Display device complies with Part 15 of the FCC Rules. Operation is subject to the following two conditions:

- (1) this device may not cause harmful interference, and
- (2) this device must accept any interference received, including interference that may cause undesired operation.



CE COMPLIANCE NOTICE



UL E211299, UL 60730-1



ELECTROSTATIC DISCHARGE CAUTION

This integrated circuit can be damaged by ESD. Failure to observe proper handling and installation procedures can cause damage. ESD damage can range from subtle performance degradation to complete device failure. Precision integrated circuits may be more susceptible to damage because very small parametric changes may cause the device to not meet its published specifications.



EMC CERTIFICATION

EN6070-1

1. Introduction	1
1.1 Overview of Capabilities	1
2. CC200 Overview	2
2.1 Expansion Module Overview	4
2.2 Case Display Overview	5
3. Powering and Wiring CC200	6
3.1 CC200 Power Wiring	7
3.2 CC200 Output Wiring	8
Fan Motors Over 5A	8
3.3 CC200 Input Wiring	9
3.4 Coil Outlet Sensor Mounting	10
3.5 Pressure Transducer Mounting	11
3.6 EEV and EEPR Location	11
3.7 Expansion Module Remote Mounting	12
3.8 CC200 Stepper Valve Wiring	13
Bipolar Stepper Valve Connections	13
Wire Specifications for extending Stepper Valves	13
CC200 Stepper Valve Specifications	14
3.9 Supported Stepper Valve List	14
3.10 PWM EEV Wiring	15
Pulse Width Modulation EEV Connections	15
3.11 CC200 Expansion Module Mounting and Installation	16
CC200 Expansion Module Specifications	17
3.12 CC200 Case Display Wiring	17

4. Control Logic Overview 19

4.1 Temperature Regulation 19

4.2 Refrigeration Specific Controls 19

4.2.1 R744 (CO2) 19

 System Overview..... 19

 Superheat Optimization (Overfeed) 19

4.2.2 A2L Refrigerants..... 20

 A2L Sensor 20

 A2L Refrigerant Leak Notification 20

 A2L Leak Mitigation Strategy 20

4.3 Superheat Regulation 20

4.4 Dual Temperature Cases..... 20

4.5 Case Lineup Management 20

4.6 Defrost Control 21

4.6.1 Manual Defrost..... 21

4.6.2 Pump Down 21

4.6.3 Termination..... 21

4.7 Demand Defrost Control 21

4.8 Fan Control 21

 Two Speed and Variable Speed Fans 22

4.9 Electric Evaporator Pressure Regulator (EEPR) 22

4.9.1 Pressure Mode 22

4.9.2 Floating SST Algorithm 22

4.9.3 Sensor Redundancy..... 23

4.10 Lighting Control 23

4.11 Door Switch..... 23

4.12 Shutdown Modes..... 23

 Service Shutdown 23

 Refrigerant Leak Shutdown..... 23

 Night Shutdown..... 23

 A2L Shutdown..... 24

4.13 Analog Inputs..... 24

4.14 Digital Inputs 24

4.15 Relay Outputs..... 25

4.16 Alarms..... 25

4.16.1 Analog Input Alarms..... 25

4.16.2 Fan Proof Alarm..... 25

4.16.3 Defrost Proof Alarm..... 25

4.16.4 Case Temperature Alarm 25

4.16.5 Communication Offline Alarms..... 25

4.16.6 Refrigerant Leak Alarm..... 25

5. CC200 Case Display26

5.1 Display Overview..... 26

5.2 Unlock and Parameter Edits..... 26

5.3 Action Icons..... 28

5.4 Status Icons 28

6. The BACnet Network29

6.1 MS/TP-IP Router Topology 29

6.2 BACnet IP with E3 Ethernet Ports..... 30

 CC200 BACnet IP Ethernet Cabling..... 32

 BACnet IP Ethernet Cable Recommended Cable Choices 32

 BACnet IP Ethernet Cable Recommended Connectors and Crimp Tools 32

 BACnet IP Ethernet Cable General Specifications..... 32

6.3 BACnet Router RS485 Detail..... 33

6.4 BACnet Router RS485 Specifications 34

6.5 Configuring BACnet Settings on the CC200 Case Display..... 35

Router Devices 35

Non-Router Devices..... 36

BACnet IP Devices for Connection to E3 36

6.6 Modbus Network..... 37

MODBUS Cable Requirements..... 37

CAT5e Cable Requirements..... 37

6.7 Configuring Modbus Settings on the CC200 Case Display 41

7. E2 Setup.....42

7.1 Set Up Network Ports and BACnet Settings..... 42

7.2 Configure E2E BACnet Settings..... 43

7.3 Add and Connect Case Controllers..... 43

7.4 Commissioning the Device in E2E..... 44

7.5 E2 Modbus Setup 45

Modbus Comm Port Setup 45

Add and Connect CC200 Devices..... 45

Commissioning the CC200 in E2E 46

8. E3 Setup - BACnet and Modbus.....47

8.1 BACnet E3 Setup for MS/TP-IP Router Networks 47

BACnet COM Port Setup..... 47

8.2 BACnet E3 Setup for ETH 1 IP Network..... 48

Add and Connect Case Controllers..... 50

8.3 Modbus E3 Setup 52

Modbus COM Port Setup..... 52

Add and Connect Case Controllers..... 53

9. Cold Chain Connect Mobile Application54

 9.1 Download the Cold Chain Connect Application..... 54

 9.2 Register the App 54

 9.3 How to Activate Bluetooth® on the CC200 Case Display 55

 9.4 Connecting to a Case 55

 9.5 Information on the Case Tab..... 55

 9.6 How to Set Parameters 56

 9.7 Manual Defrost 56

 9.8 Calibrate Valve 57

 9.9 Overrides 57

 9.10 Restart the CC200..... 57

 9.11 Real-Time Graphs..... 58

 9.12 Viewing Alarms..... 58

 9.13 Info..... 59

 9.14 Disconnect from the Case..... 59

10. Configuring CC200 Parameters.....60

11. Technical Specifications and Part Numbers68

 11.1 CC200 Case Controller Specifications 68

 11.2 CC200 Power Supply Specifications..... 68

 11.3 CC200 Case Expansion Module Specifications 69

 11.4 CC200 Case Display Specifications 69

 11.5 Part Numbers for Ordering..... 70

Appendix A: CC200 Parameters71





Appendix B: Dimensions94

Appendix C: Door Switch Mounting and Wiring Hinged Doors95



Appendix D: Door Switch Mounting and Wiring Sliding Doors.....96

Appendix E: 118-4101 Door Switch Dimensions97

Safety Icon Explanation

 DANGER	DANGER indicates a hazardous situation which, if not avoided, will result in death or serious injury.
 WARNING	WARNING indicates a hazardous situation which, if not avoided, could result in death or serious injury.
 CAUTION	CAUTION used with the safety alert symbol, indicates a hazardous situation which, if not avoided, could result in minor or moderate injury.
NOTICE	NOTICE is used to address practices not related to personal injury.
CAUTION	CAUTION without the safety alert symbol, is used to address practices not related to personal injury.
 FLAMMABLE	FLAMMABLE Fire hazard! Sparking in a potentially explosive atmosphere! Explosion hazard!

Instructions Pertaining to Risk of Electrical Shock, Fire, or Injury to Persons

 WARNING	<p>PLEASE READ BEFORE USING THIS DEVICE</p> <ul style="list-style-type: none">• This manual is part of the product and should be kept near the instrument for easy and quick reference.• The instrument shall not be used for purposes different from those described hereunder. It cannot be used as a safety device.• Check the application limits before proceeding.• Copeland reserves the right to change the composition of its products, even without notice, ensuring the same and unchanged functionality.
 WARNING	<p>PLEASE READ BEFORE USING THIS DEVICE</p> <ul style="list-style-type: none">• Verify that the supply voltage is correct before connecting the instrument.• Do not expose the gateway to water or moisture: use the devices only within the operating limits avoiding sudden temperature changes with high atmospheric humidity to prevent formation of condensation.• Warning: disconnect all electrical connections before any kind of maintenance.• Fit the transmitter where it is accessible by the End User for troubleshooting and replacement. The instrument must not be opened.• In case of failure or faulty operation send the instrument back to the distributor or to "Copeland" (see address) with a detailed description of the fault.

1. Introduction

The Case Controller 200 (CC200) is a microprocessor-based controller for use in controlling temperature and Superheat in refrigerated fixtures and walk-in boxes. The controller is suitable for medium and low temperature applications and can control all loads in a refrigerated box or fixture for up to three evaporator coils. These include lighting, fans, defrost heaters, solenoid valves, stepper valves, and pulse width modulation valves. The CC200 control system consists of at least one CC200, one CC200 Case Display and optionally up to three CC200 Expansion Modules (CEM) depending on the case installation. When more than one case or fixture is used within the refrigeration circuit, the Case Controller can communicate critical information between other peer controllers in the lineup. This peer communication allows the CC200 to efficiently coordinate defrost, monitor temperatures, collect data, and offer sensor redundancy to keep the system running at all times. The controller can be integrated into a Supervisory Controller and is currently integrated into the Copeland E2E and E3 Supervisory Controllers using BACnet and Modbus. While integrated with E2E or E3, the CC200 runs completely stand-alone and requires no Supervisory Controller instructions or commands.



1.1 Overview of Capabilities

- Seamless coordination of refrigeration case lineups with support for up to 8 cases in a lineup.
- Manages all loads in a refrigerated case: lighting, fans, defrost heaters, LLSV, expansion valves, EEPR.
- EEPR control based on air temperature or suction pressure.
- Precise control of evaporator Superheat using Stepper EEV or PWM EEV
- Patient pending floating evaporator SST setpoint management automatically adjust evaporator SST to the optimum setpoint for discharge air.
- CO₂ capable pressure transducers, superheat control, and safeties.
- Superheat optimization feature enables operation in ultra low superheat CO₂ system designs.
- Demand defrost algorithm, reduces energy consumption and keeps evaporator free from frost.
- Modular design allows up to three (3) evaporator coils per case
- Low, medium, and dual temperature case types.
- Built-in sensor redundancy algorithms keep the system running.
- Single power supply for CC200, expansion modules and display simplify wiring and reduce labor cost.
- Form C relays allow direct control of case loads and allow simplified wiring
- Bluetooth® connectivity for easy controller status and service.
- Communicates with a Supervisory Controller via BACnet or Modbus.
- Supports A2L refrigerant and leak mitigation strategy.
- Supports two-speed and variable speed fans
- Night Shutdown mode
- Refrigerant Overfeed for Supervisor Controller

2. CC200 Overview



CC200 Hardware Platform

CC200 is built with the necessary onboard IO to perform precise control of a refrigerated case or walk-in box in many different system configurations.

- One TRIAC for control of PWM (pulse width modulation) EEV valve or one stepper motor control for EEPR stepper or EEV stepper.
- Five form C relays for controlling fan, defrost, lights and LLSV.
- Fan relay utilizes onboard amperage monitoring for low amperage ECM fan motors.
- Two RS485 ports for integration to Supervisor Controllers.
- Two RJ45 ports for BACnet IP daisy chain network.
- Four digital inputs: user-configurable purpose.
- Two analog outputs 0-10VDC or 4-20mA: user-configurable purpose.
- One pressure input for suction pressure transducer.
- Three color-coded temperature inputs for discharge air, return air, and defrost termination plus coil out temperature.
- One defrost current transducer input for heater amperage monitoring.
- Two auxiliary analog inputs: user-configurable purpose.
- Expansion port connector for easily adding additional IO via CC200 Expansion Module.

Legend

Terminal	Label	Purpose
1-3	TRIAC	Connection of PWM expansion valve
4-6	FAN/CT	Fan control relay. Connection of evaporator fan motor or control point (contactor/pilot relay). Internal amperage monitor measures motor current.
5-9	DEFROST	Defrost control relay. Connection of defrost heater or control point (contactor/pilot relay).
10-12	LIGHT	Light control relay. Connection of case lights.
13 - 15	REFRIG	Refrigeration control relay for connection of liquid line solenoid valve (if present).
16 - 18	AUX RELAY	Auxiliary control relay for spare or additional functions.
21 - 23	RS485 Port A	RS485 serial communications port.
24 - 26	RS485 Port B	RS485 serial communications port for BACnet MS/TP connection to E2E.
27 - 29	Remote Display	Connection for CC200 case display.
NA	ETH1	RJ45 Ethernet 1 used for case lineup peer communication and BACnet IP.
NA	ETH2	RJ45 Ethernet 2 used for case lineup peer communication and BACnet IP.
NA	USB	Universal Serial Bus female connector. Copeland use only.
NA	Auxiliary Port	Connection to CC200 expansion module if present.
NA	Expansion Port	Connection to CC200 expansion module if present.
31 - 32	DI1-C	Potential free digital Input 1 and common. Software selectable function.
33 - 35	DI2-C	Potential free digital Input 2 and common. Software selectable function.
35 - 37	DI3-C	Potential free digital Input 3 and common. Software selectable function.
37 - 39	DI4-C	Potential free digital Input 4 and common. Software selectable function.
39 - 40	AO1	Analog output 1 connection, software selectable function.
31 - 42	AO2	Analog output 2 connection, software selectable function.
43 - 45	Pressure 0V, Sig, +5v	Pressure transducer connection, .5-4.5VDC software selectable EU range.
46 - 47	DAT	Discharge air temperature sensor connection, non-polarity sensitive.
48 - 49	Term	Defrost termination temperature sensor connection, non-polarity sensitive.
50 - 51	RAT	Return air temperature sensor connection, non-polarity sensitive.
52 - 53	Coil Out	Coil outlet temperature sensor connection, non-polarity sensitive.
54 - 55	Def CT Amps	Defrost heater amperage current transducer, optional.
56 - 57	AI 1	Auxiliary analog input 1 connection, software selectable function.
58 - 59	AI 2	Auxiliary analog input 2 connection, software selectable function.
60 - 61	Aux Pwr	Auxiliary power supply for transducers requiring 12VDC external power.
NA	PWR ON	Power on LED, indicates supply power is present to the main controller.
71	Earth	Earth ground connection for the main controller.
72 - 73	POWER SUPPLY 24VDC	Supply power connection for 24VDC, polarity sensitive + to + and - to - must be observed.
74 - 75	STEPPER BATTERY	Future option for battery backup to drive stepper valves to safe position during power failure.
NA	Valve Open Close	LED for open and close indication of attached stepper valve.
76 - 77	STEPPER VALVE W2	Winding 2 connection for stepper valve motor wiring harness.
78 - 79	STEPPER VALVE W1	Winding 1 connection for stepper valve motor wiring harness.
80	STEPPER+ 12V	12V for unipolar stepper motors.

2.1 Expansion Module Overview

CC200 Expansion module is built with the necessary onboard IO to add additional IO for modular coil case designs or multi-evaporator walk-in boxes.

- One TRIAC for control of PWM (pulse width modulation) EEV valve or one stepper motor control for EEPR stepper or EEV stepper.
- One digital input: user-configurable purposes.
- One pressure input for suction pressure transducer.
- Three color-coded temperature inputs for discharge air, return air, and defrost termination plus coil out temperature.
- Expansion port connector for easy connection to CC200 Main Controller or an additional Expansion module.



Expansion Module Hardware Platform

Legend		
Terminal	Label	Purpose
4 - 6	TRIAC	Connection of PWM expansion valve.
NA	ADDRESS	Dip switch band for setting communication bus address.
NA	PWR ON	Power on LED, indicates supply power is present to the main controller.
NA	Valve Open - Close	LED for open and close indication of attached stepper valve.
NA	Expansion Port	Connection to CC200 Main Controller or an additional Expansion Module.
10 - 11	DI1-C	Potential free Digital Input 1 and common. Software selectable function.
12 - 14	Pressure 0V, Sig, +5V	Pressure transducer connection, .5-4.5VDC software selectable EU range.
15	+12V	Auxiliary power supply for transducers requiring 12VDC external power.
16 - 17	DAT	Discharge air temperature sensor connection, non-polarity sensitive.
18 - 19	Term	Defrost termination temperature sensor connection, non-polarity sensitive.
20 - 21	RAT	Return air temperature sensor connection, non-polarity sensitive.
22 - 23	Coil Out	Coil outlet temperature sensor connection, non-polarity sensitive.
33 - 34	STEPPER VALVE W2	Winding 2 connection for stepper valve motor wiring harness.
35 - 36	STEPPER VALVE W1	Winding 1 connection for stepper valve motor wiring harness.
37	STEPPER + 12V	12V for unipolar stepper motors.

2.2 Case Display Overview

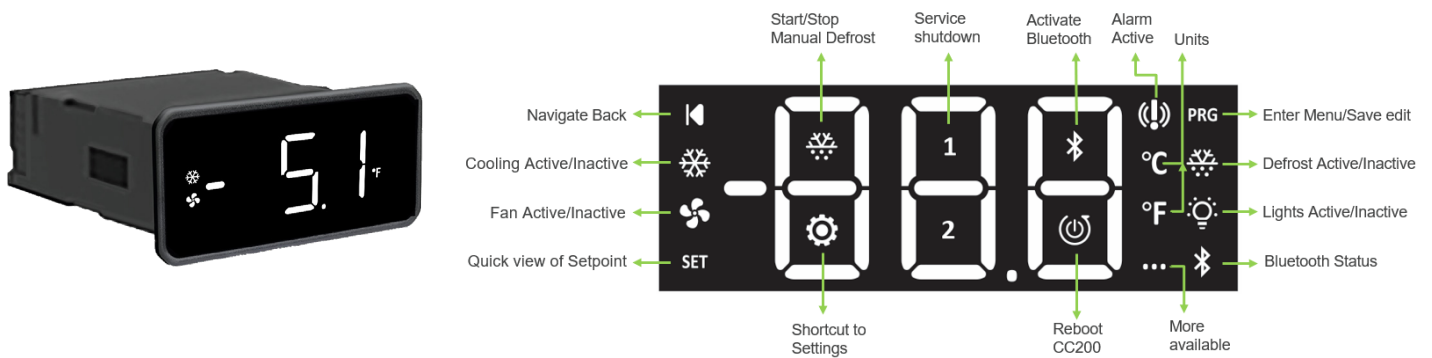

Item	Description
Navigate Back	Navigate back, tap once to navigate back to previous menu.
Cooling Active/Inactive	Refrigeration active icon, status of if the system is actively cooling.
Fan Active/Inactive	Evaporator fan icon, status of evaporator fan motor command.
Quick view of Setpoint	SET provides quick access to view the setpoint, tap once to view the current active air setpoint.
Start/Stop Manual Defrost	Manual defrost action icon, long press to start or stop a manual defrost.
Service Shutdown	Service shutdown action icon, long press to start or stop a service shutdown.
Activate Bluetooth®	Bluetooth® activation icon, long press to switch on/off Bluetooth®.
Alarm Active	Alarm indicator icon, illuminates when at least one alarm is present.
Enter Menu/Save Edit	PRG button to enter menus and save parameter edits.
Defrost Active/Inactive	Defrost active icon, illuminates when defrost cycle is active.
Lights Active/Inactive	Lights active icon, illuminates when case lighting is on.
Bluetooth® Status	Bluetooth® connection status, blinks when ready to connect, solid on when connected to mobile device.
Shortcut to Settings	Shortcut to Modbus and BACnet addressing menu, long press to enter Modbus and BACnet settings menu.
Reboot CC200	Reboot CC200 action icon, long press to reboot CC200 controller.
More Available	More pages indicator, present when more content is available by swiping.
Units	Celsius/Fahrenheit temperature engineering unit label.

3. Powering and Wiring CC200

An overall connection detail is shown below for reference. Detailed instructions on powering and wiring are included in the following sections.

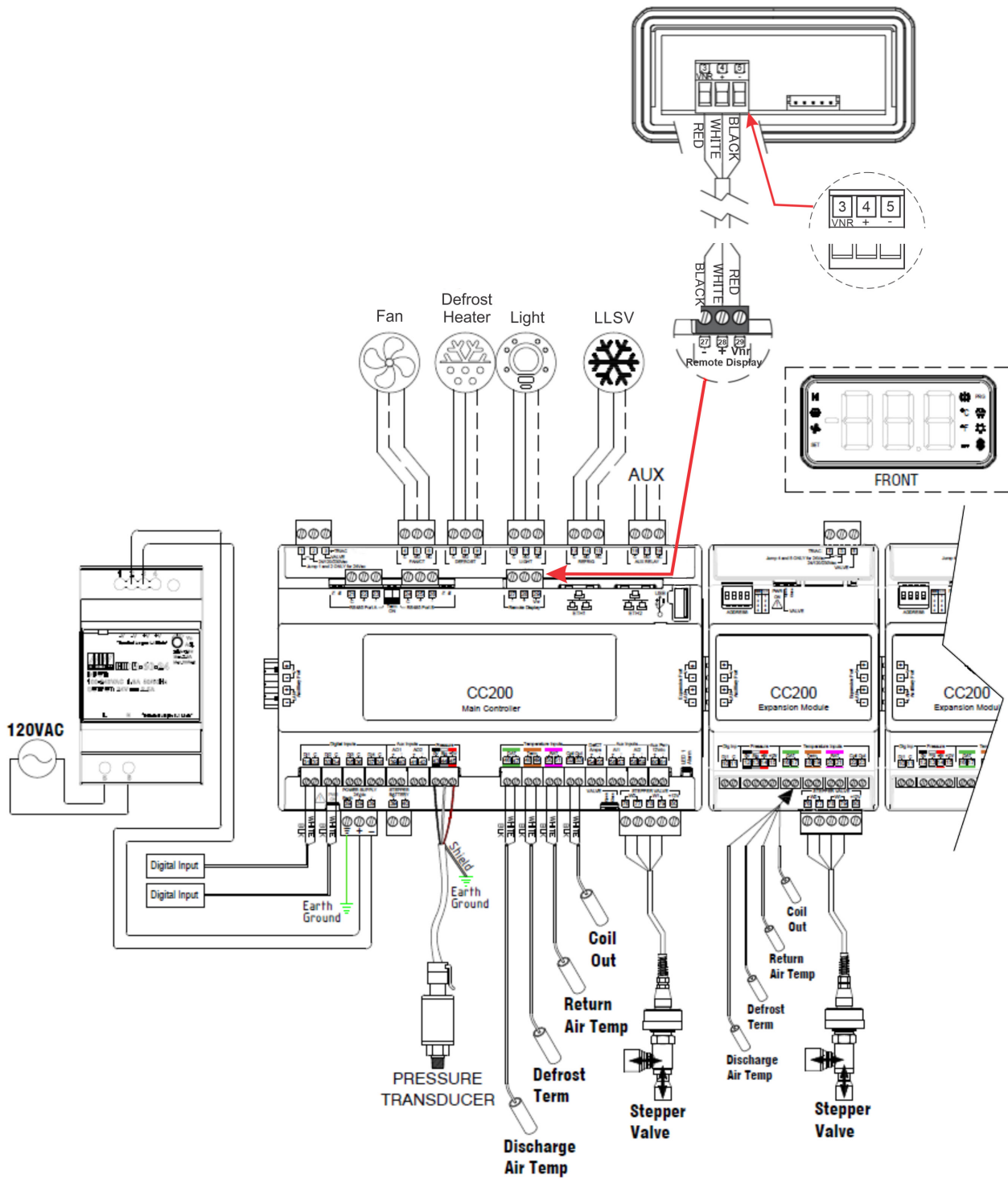

CC200 Wiring and Connections

3.1 CC200 Power Wiring

CC200 must be powered by an Copeland CC200 24VDC power supply P/N 318-3183. Connect the 24VDC power supply to the CC200 by connecting two (2) wires from the power supply port terminals labeled -V and +V to the CC200 power 24VDC connector port numbers 72 (+) and 73 (-). Wire the power supply terminal -V to CC200 (-) and power supply terminal +V to CC200 (+) using 16AWG or larger wire.

Connect **Earth** terminal 71 to earth/chassis earth ground. For earth/chassis connection use 16AWG or larger and keep length as short as possible.

Step 1: Mount Power Supply and CC200 Main Controller to DIN Rail.

Step 2: Wire Secondary Power from Power Supply to CC200 Main Controller.

- a. Reference specification and drawing for Terminals
- b. This is Polarity Sensitive

Step 3: Wire Primary power to Power Supply.

- a. Reference the specification and drawing for Terminals

Step 4: Once primary power is supplied to the power supply, the CC200 PWR ON LED will illuminate steadily ON.

Note: If the CC200 system has three (3) expansion modules, the 92W P/N 318-3184 power supply is required.

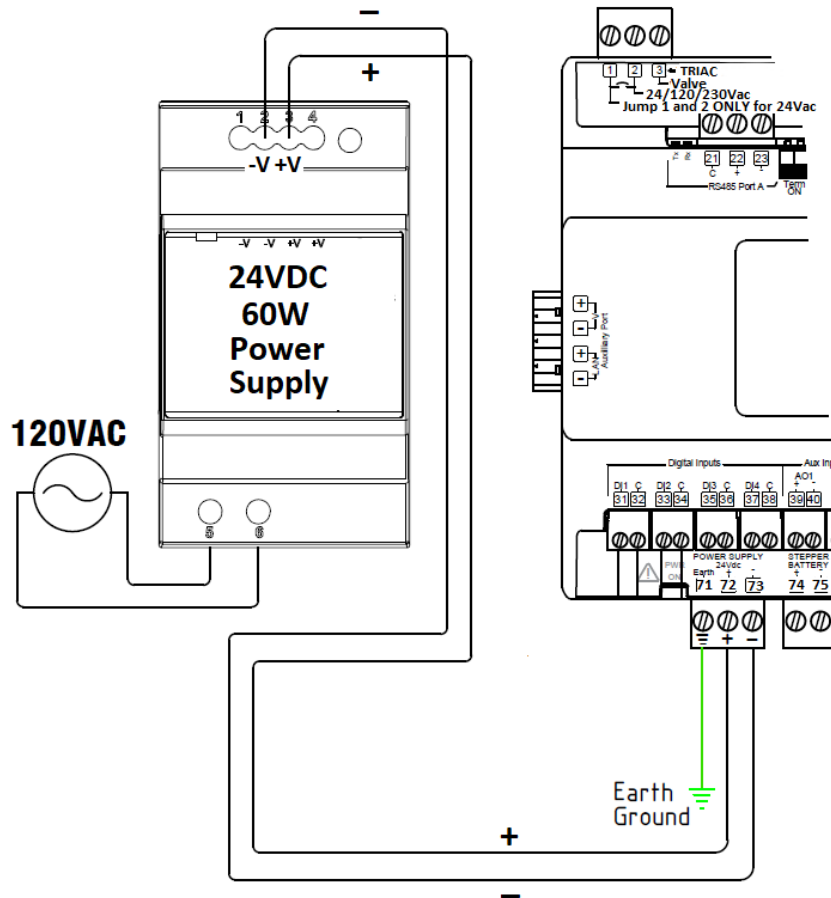

CC200 Power Supply Wiring

3.2 CC200 Output Wiring

Step 1: Verify power is OFF on the CC200 Main Controller.

Step 2: Refer to the specification drawing below for the correct termination terminals and how to wire.

- For fan motors larger than 5AAC the alternate wiring method with a pilot device is required (see [Alternative Fans Over 5 Amps](#) diagram).

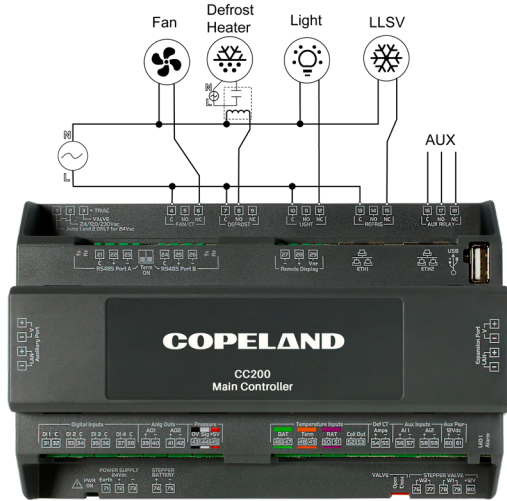

Output Wiring

Fan Motors Over 5A

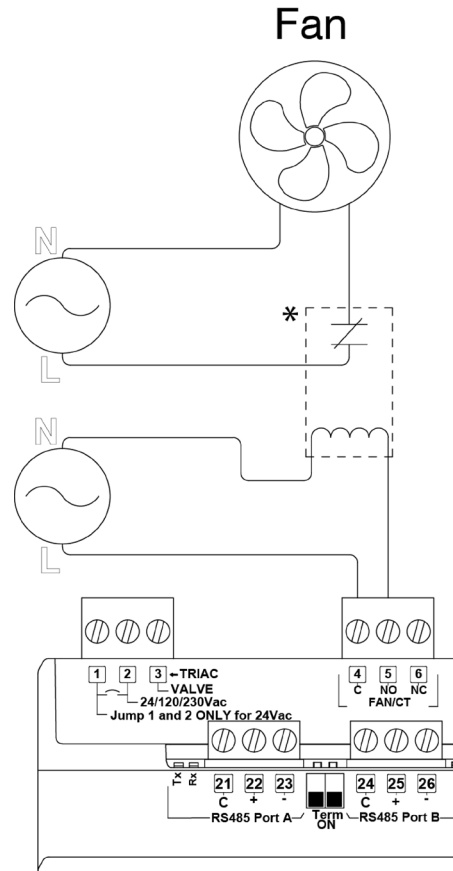

Alternative Fans Over 5 Amps

CC200 Main Controller Output Specifications

Relay Specifications			
CC200 Label	AMP/VAC	Loads Controlled	Terminals
FAN/CT	Form C Relay with built in CT NO: Resistive 5A, 240Vac or less Motor 5 FLA, 30LRA, 240Vac or less Pilot Duty B300 NC: Resistive 5A, 240Vac or less Motor 5 FLA, 30LRA, 240Vac or less Pilot Duty C300	Evap Fans	4(C) - 5(NO) - 6 (NC)
DEFROST	Form C Relay NO:	Defrost Heaters	7(C) - 8(NO) - 9(NC)
LIGHT	Resistive 12A, 240Vac or less Motor 10FLA, 60LRA, 240Vac or less Pilot Duty B300 NC:	Case Lights	10(C) - 11(NO) - 12(NC)
REFRIG	Resistive 12A, 240Vac or less Motor 5 FLA, 30LRA, 240Vac or less Pilot Duty C300	LLSV	13(C) - 14(NO) - 15(NC)
AUX RELAY	Resistive 12A, 240Vac or less Motor 5 FLA, 30LRA, 240Vac or less Pilot Duty C300	Alarm Out, Door Alarm, Satellite for E2E control, Backup for other RO	16(C) - 17(NO) - 18(NC)
AO1 (AO)	4-20mA -10VDC	Satellite for E2E control, Future Light Dimming, Future Anti-sweat	39(+)- 40(-)
AO2 (AO)	4-20mA or 0-10VDC	Future Light Dimming	4 1(+)- 42(-)
TRIAC	20W Max 24/120/230Vac	PMW Valve	1(Jmp) - 2(Line) - 3(Valve) Jump Terminals 1 and 2 ONLY for 24Vac Valve

3.3 CC200 Input Wiring

The commonly used CC200 inputs have been color coded for ease of wiring.

Connect pressure transducer to Pressure terminals 43, 44, 45 labeled **0V (black)**, **Sig (white)**, **+5V (red)**. Connect the shield wire to earth ground at the control cabinet only. DO NOT connect the shield wire to any connector on the CC200. Temperature input connections are made at the **Temperature Inputs** terminals labeled **DAT - Green** (Discharge Air Temp 46, 47); **Term - Orange** (Defrost Termination 48, 49); **RAT - Purple** (Return Air Temp 50, 51); **Coil Out** - (52, 53).

Step 1: Make sure the power is OFF to the CC200 Main Controller.

Step 2: Determine what sensors will be needed and wire per the specification above.

If the sensor needs to be extended, Copeland only supports heat shrink and solder.

Step 3: Determine how many coils are on the cases.

For multi-coil cases the CC200 supports one sensor per coil for discharge air, return air, defrost termination and coil outlet. Pressure transducers for multi-coil cases may be installed one per coil or one for the entire case (parameter selectable). When only one transducer per case is installed, wire the transducer to the CC200 Main Controller pressure input terminals 43-45.

For multi-coil cases the sensors on coil #1 will terminate on the CC200 Main Controller. Second and third sensor coils will require an Expansion Module per coil and each coil's sensor will terminate on each of the Expansion Modules.

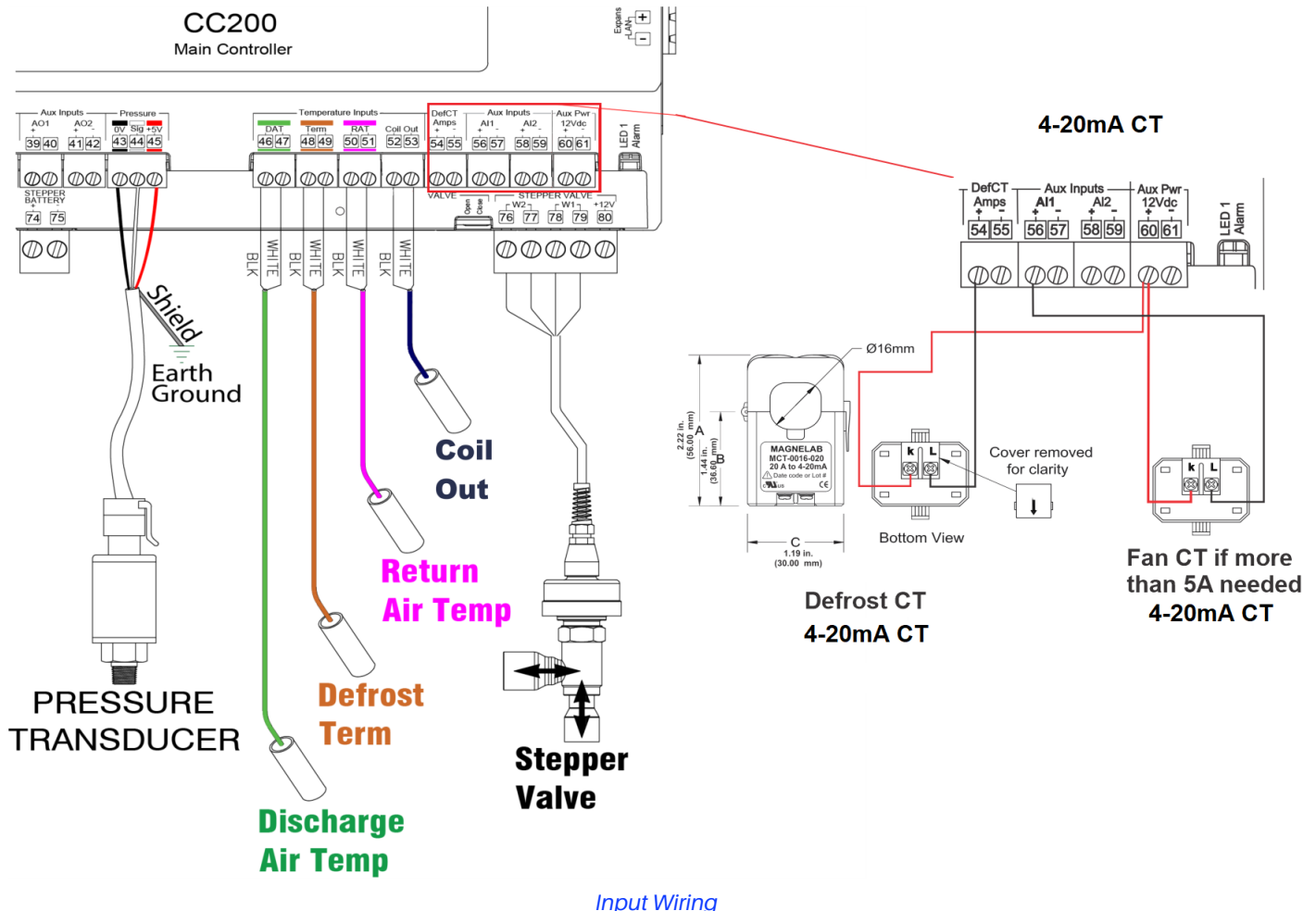

CC200 Main Controller Input Specifications

Input Specifications		
CC200 Label	Description	Terminals & Color
DAT	Discharge Air	46 - 47 Green
TERM	Defrost Termination	48 - 49 Orange
RAT	Return Air	50 - 51 Purple
COIL OUT	Coil Out	52 - 53
PRESSURE	100lb, 150lb, 200lb, 300lb, 500lb, 650lb, and Custom Pressure Transducer Polarity sensitive	43(0v) - 44(Sig) - 45(+5V) Black - White - Red
Def CT Amps	Defrost Amps (electric defrost only)	54(+) - 55(-)

Aux Inputs AI & DI		
AI1 AI2	Configurable functions: External fan CT, Coil Inlet Temp, Product Temp, Circuit Suction Temp	56(+) - 57(-) 58(+) - 59(-)
DI1 DI2 DI3 DI4	Door switch, service switch, dual temp switch, defrost term switch, leak shutdown, satellite 1 for E2E, satellite 2 for E2E, Reset A2L Alarm	31(DI1) - 32(C) 33(DI2) - 34(C) 35(DI3) - 36(C) 37(DI4) - 38(C)

Wire Specifications for Extending Inputs	
Analog Temp Sensors or Digital Inputs	General Cable 92454A Copeland P/N 135-0600 or Belden 8761 Copeland P/N 035-0002 or equivalent 2 conductor shielded 22 AWG or larger cable may be used to extend length to a maximum of 50 ft. <u>If manufacturer harness must be extended, join wires with heat shrink and solder.</u>
Pressure Transducer	Belden 28326AS Copeland P/N 135-2832 or Belden 8771 Copeland P/N 135-8771 or equivalent 3 conductor shielded 22 AWG or larger cable may be used to extend length to a maximum of 50 ft. <u>If manufacturer harness must be extended, join wires with heat shrink and solder.</u>

3.4 Coil Outlet Sensor Mounting

For proper superheat monitoring and control, the coil outlet sensor is required to make the superheat calculation. The coil outlet sensor must be mounted on a clean, straight, horizontal oriented piece of suction pipe. Ideally no more than 16 inches from the exit of the evaporator coil housing. The sensor probe must be tightly secured to the suction pipe in the 4 or 8 o'clock position with two heavy duty zip ties. Once secured the sensor should be insulated well with black cork tape insulation or equivalent adhesive insulation.

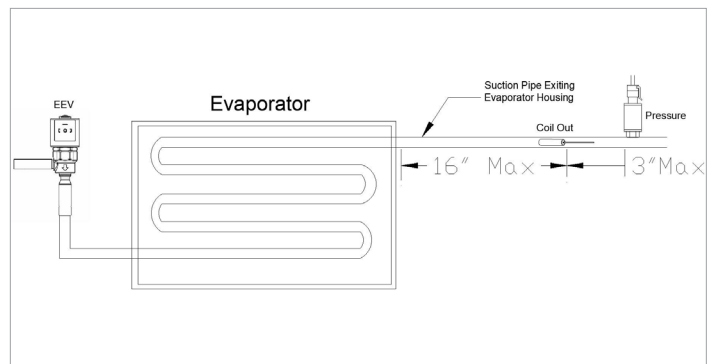
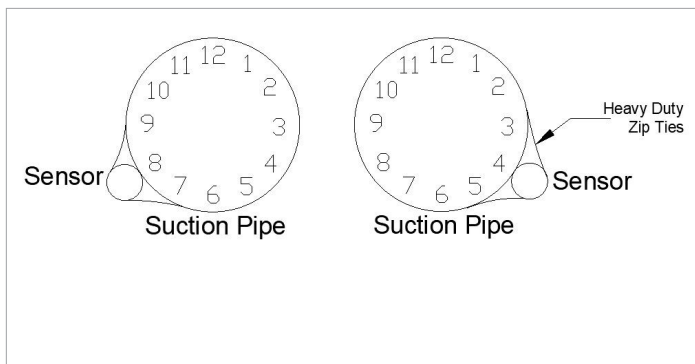

3.5 Pressure Transducer Mounting

For proper superheat monitoring and control the pressure transducer is required to make the superheat calculation. The pressure transducer must be mounted on a clean, straight, horizontal-oriented piece of suction pipe. Install the transducer in the 12 o'clock position on the suction pipe no more than 3 inches from the coil outlet sensor location.

3.6 EEV and EEPR Location

The CC200 Case control system (Main Controller + Expansion Modules) supports Electronic Expansion Valve (EEV) control using either Pulse Width Modulation (PWM) valves OR Stepper valves but NOT both. The first case in a CC200 lineup ("a" Case) has support for control of Electronic Evaporator Pressure Regulation (EEPR) stepper valve.

- PWM EEV 1 or Stepper EEV 1 is always located on CC200 Main Controller.
- PWM EEV 2 or Stepper EEV 2 is always located on Expansion Module 1.
- PWM EEV 3 or Stepper EEV 3 is always located on Expansion Module 2.
- EEPR Location
 - When WM EEV is used, EEPR is always located on CC200 Main Controller Stepper terminals.
 - When Stepper EEV is used, EEPR is located on the last Expansion Module Stepper terminals.

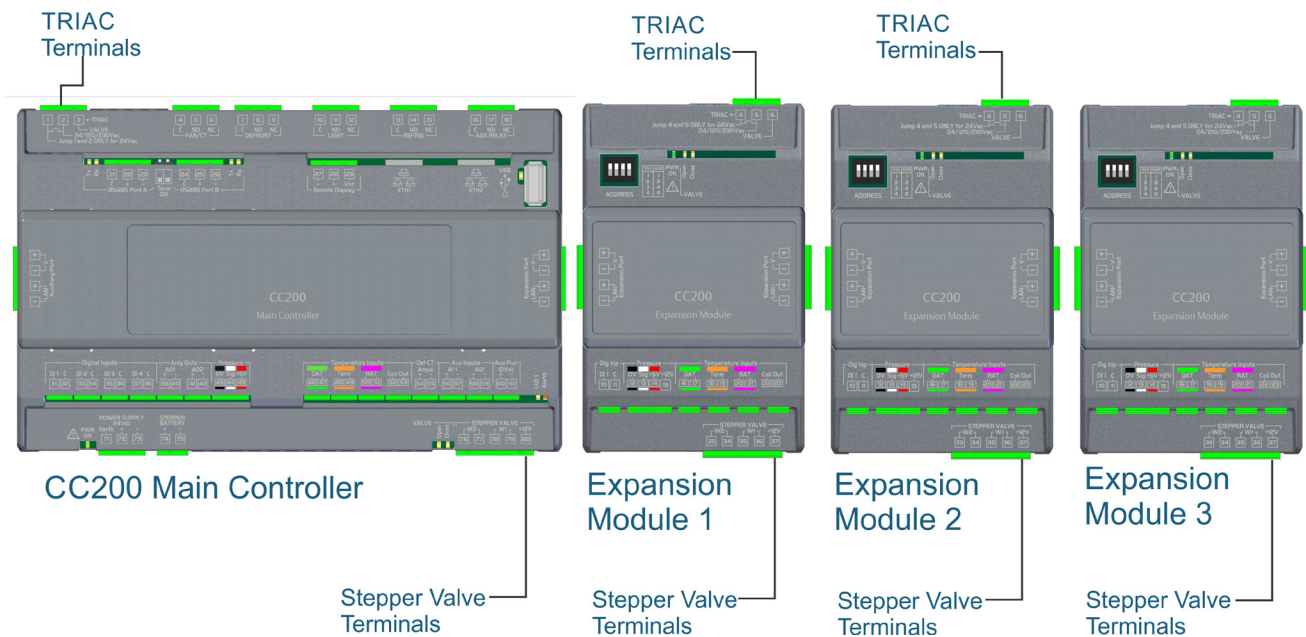

3.7 Expansion Module Remote Mounting

If the CC200 Main Controller and all required CC200 Expansion Modules cannot be mounted side by side on the same section of DIN rail, the CC200 Expansion Modules may be mounted near the CC200 Main Controller using extension harness(s) made from Belden 28326AS **Copeland P/N 135-2832** or Belden 9418 **Copeland P/N 135-9418** or equivalent 4 conductor shielded 18 AWG cable with total length of cable(s) from CC200 Main Controller to all CC200 Expansion Modules not to exceed **10 feet**. Additionally, one **CC200 Expansion Port Connector Set P/N 318-3185** will be needed for each section of the harness extension. Shield must not be connected to any terminal or earth ground (just inside the cable). Clip shield at both ends and insulate with heat shrink. Do not connect shield wire to any CC200 terminal, earth, or chassis ground.

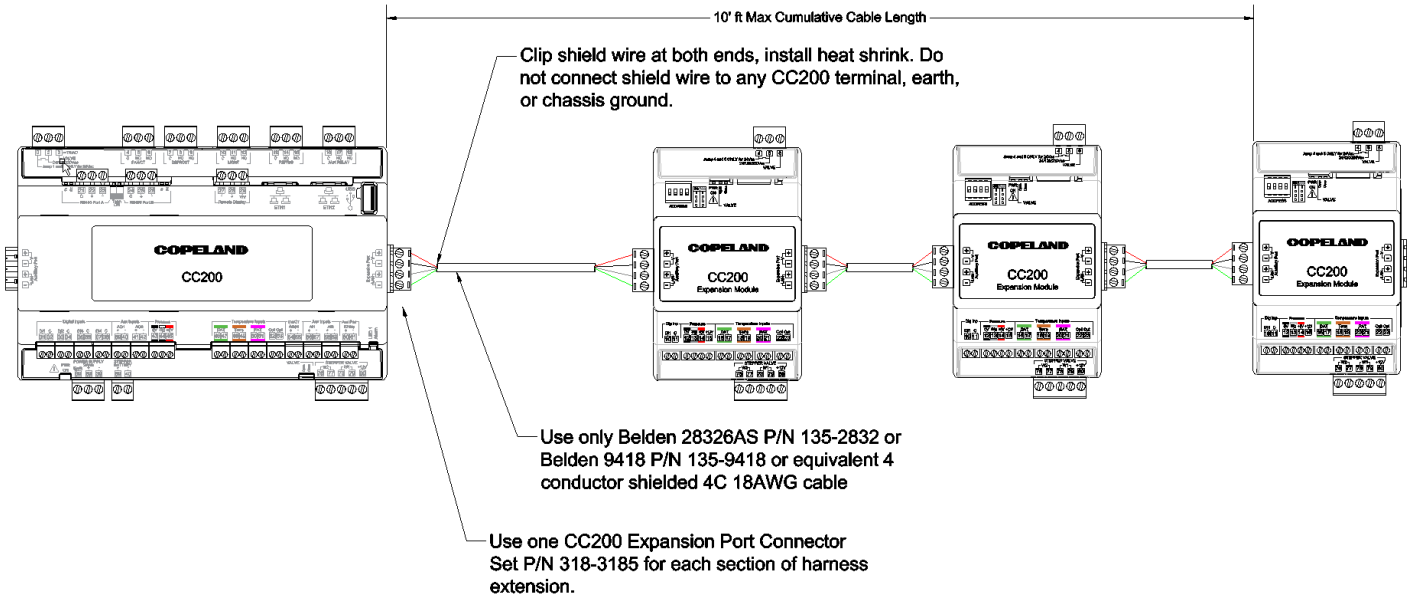

Connector	Part Number
CC200 Expansion Port Connector Set	P/N: 318-3185
Male Only 1757035	P/N: 045-9400
Female Only 1786190	P/N: 045-9154

3.8 CC200 Stepper Valve Wiring

Bipolar Stepper Valve Connections

Refer to [Section 3.6, EEV and EEPR Location](#) to determine the proper location for the valve.

The CC200 Main Controller Stepper valve connections are made at the terminals labeled STEPPER VALVE using **W1** and **W2** (for Sporlan valve wire colors only) **W2** (white=76, black=77) and **W1** (red=78, green=79). The CC200 Expansion Module Stepper valve connections are made at the terminals labeled STEPPER VALVE using W1 and W2 (for Sporlan valve wire colors only), W2 (white=33, black=34), and W1 (red=35, green=36).

Wire Specifications for extending Stepper Valves

- **EEV Stepper (Unipolar):** Use the manufacturer harness with a maximum length not to exceed **30 ft** (10 meters).
- **EEV Stepper (Bipolar):** Always use the manufacturer harness first with a maximum length not to exceed 40 ft (12 meters). If the manufacturer harness must be extended, Belden 28326AS Copeland P/N 135-2832 or Belden 9418 Copeland P/N 135-9418 or equivalent 4 conductor shielded 18 AWG or larger cable may be used to extend length to a maximum of **75 ft**. Join wires with solder and insulate with heat shrink tubing.
For walk in cooler or freezer applications that require the manufacturer harness to be extended, installers must use: Belden 28326AS Copeland P/N 135-2832 or Belden 9418 Copeland P/N 135-9418 or equivalent 4 conductor shielded 18 AWG or larger cable may be used to extend length to a maximum of **75 ft**. **If manufacturer harness must be extended, join wires with solder and heat shrink to insulate.**
- **EEPR Stepper (Bipolar):** Belden 28326AS Copeland P/N 135-2832 or Belden 9418 Copeland P/N 135-9418 or equivalent 4 conductor shielded 18 AWG or larger cable may be used to extend length to a maximum of **75 ft**. **If manufacturer harness must be extended, join wires with solder and heat shrink to insulate.**

Step 1: Make sure the power is OFF to the CC200 Main Controller and Expansion Module.

- a. The wiring specification above is only for Sporlan Bipolar CDS valves or Sporlan SER EEV valves.
- b. If other manufacturer valves are used, refer to the manufacturer's specification and contact Copeland for instructions on how to terminate.

Step 2: Refer to the drawing and specification for termination of the valve.

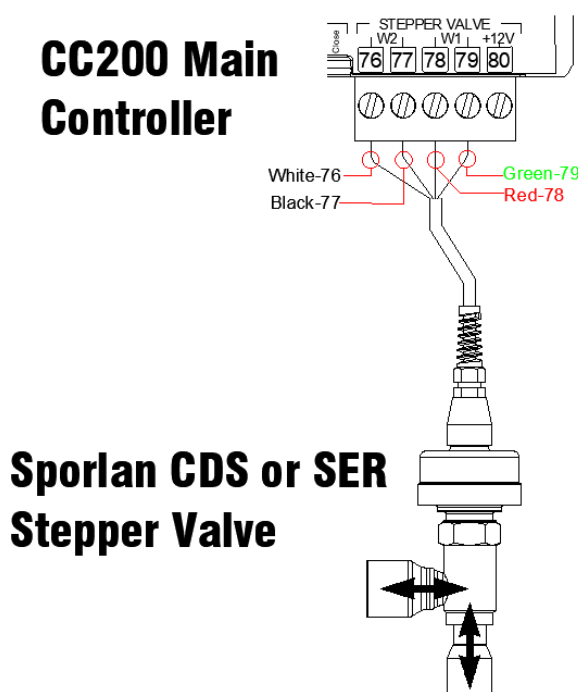

Main Controller Stepper Valve Wiring

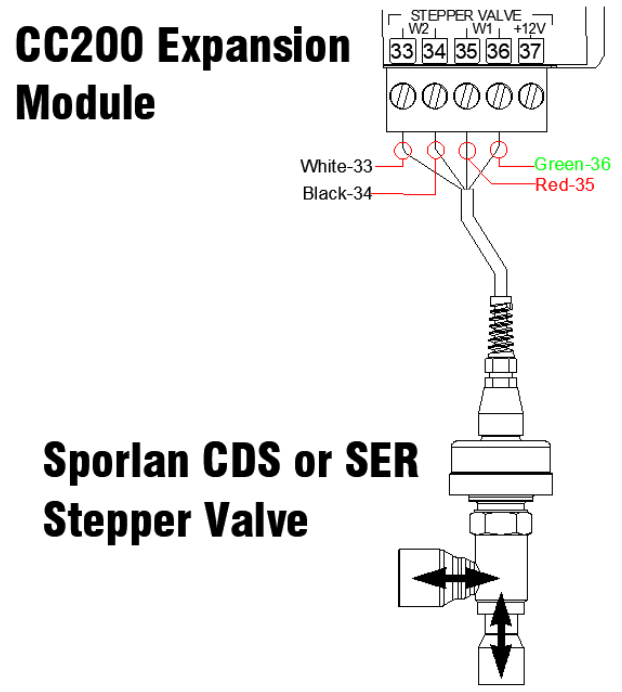

Expansion Module Stepper Valve Wiring

CC200 Stepper Valve Specifications

- Each CC200 STEPPER VALVE output when configured as “Bipolar” is capable of supplying up to 500mA/phase and driving 12 Volt 2-Phase bipolar permanent magnet stepper valves with constant 12 volts using Full Step mode 4-step drive sequence. **Bipolar stepper valves with phase resistance less than 26 ohms or that require a voltage chopper constant current driver, CANNOT be driven with the CC200 system.**
- Each CC200 STEPPER VALVE output when configured as “Unipolar” is capable of supplying up to 300mA/phase and driving 12 Volt 5-wire unipolar permanent magnet stepper valves with 1-2 Phase Half Step 8 pulse control sequence. **Unipolar stepper valves with phase resistance less than 40 ohms CANNOT be driven with the CC200 system.**

Stepper Valve (Sporlan CDS or SER)	
Stepper Valve	Bipolar
	W2
	76(White) – 77(Black)
	W1
Stepper Valve - Expansion Module	Bipolar
	W2
	78(Red) – 79(Green)
	W1
Stepper Valve - Expansion Module	Bipolar
	W2
	Stepper Valve - Expansion Module
	W1
Stepper Valve - Expansion Module	Bipolar
	W1

Wire Specs for Extending Valves	
EEV Stepper (Unipolar)	Use the manufacturer harness with a maximum length not to exceed 30 ft (10 meters).
EEPR Stepper (Bipolar) EEV Stepper (Bipolar Walk-in applications)	Belden 28326AS Copeland P/N 135-2832 or Belden 9418 Copeland P/N 135-9418 or equivalent 4 conductor shielded 18 AWG or larger cable may be used to extend length to a maximum of 75 ft . <u>If manufacturer harness must be extended, join wires with solder and insulate with heat shrink tubing.</u>

3.9 Supported Stepper Valve List

The table below shows supported valves with recommended parameter values to configure each valve. For any valves not listed, obtain the valve manufacturer data sheet and contact Copeland for details on how to operate the valve with CC200.

Valve Model	Motor Type	Max Steps	Step Rate	Overclose	Relax Steps
Sporlan SER-A, A(HP) AA, B, C, D	Bipolar	2500	200	10%	8
Sporlan SERI-G, J, K, L	Bipolar	2500	200	10%	8
Sporlan SER 1.5-20	Bipolar	1596	200	10%	8
Sporlan SEHI-100, 175	Bipolar	6386	200	10%	8
Sporlan SEI .5-11	Bipolar	1596	200	10%	8
Sporlan SEI 30	Bipolar	3064	200	10%	8
Sporlan SEI 50	Bipolar	6386	200	10%	8
Sporlan CDS or CDST 2, 4, 7	Bipolar	2500	200	10%	8
Sporlan CDS or CDST 9, 16, 17	Bipolar	6386	200	10%	8

Note: CC200 stepper valve calibration defaults to once per day during the first defrost. If valve calibration parameter is changed to every defrost, adjust the overclose % parameter to 5%.

3.10 PWM EEV Wiring

Pulse Width Modulation EEV Connections

Refer to [Section 3.6, EEV and EEPR Location](#) to determine the proper location for the PWM EEV valve.

Step 1: Power down the CC200 controller.

Step 2: De-energize the supply power circuit that will power the PWM valve coil. **Verify all wires and circuits are in an electrically safe work condition prior to performing any wiring.**

Step 3: Refer to the below diagram for 120V valve coils only, complete the terminations as shown in the diagram. The PWM valve ground wire or terminal should be securely connected to 120VAC supply circuit ground. **Do not connect PWM valve ground wire to any CC200 terminal.**

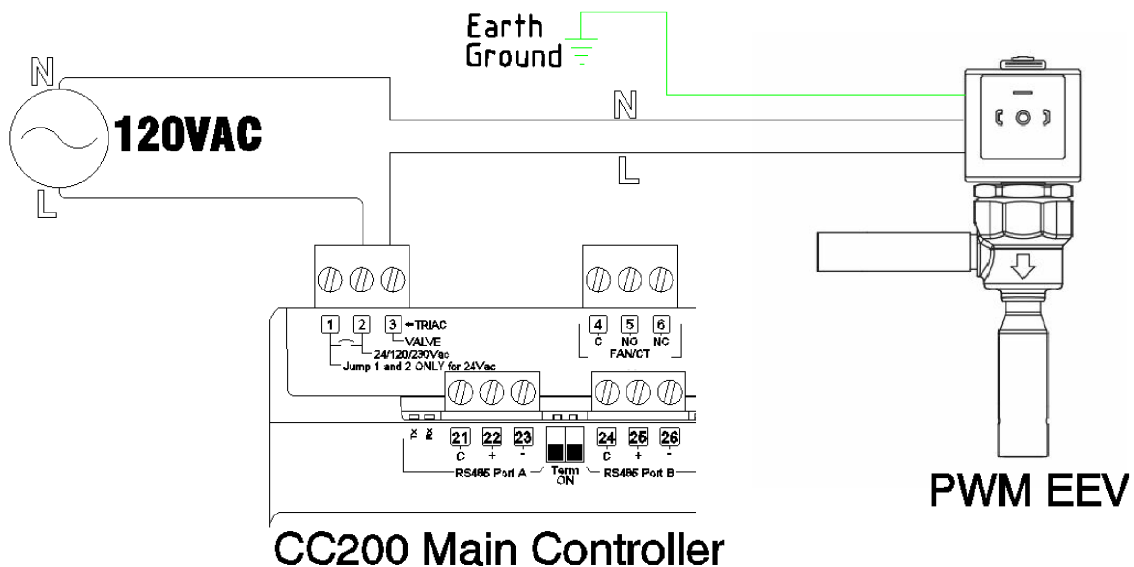
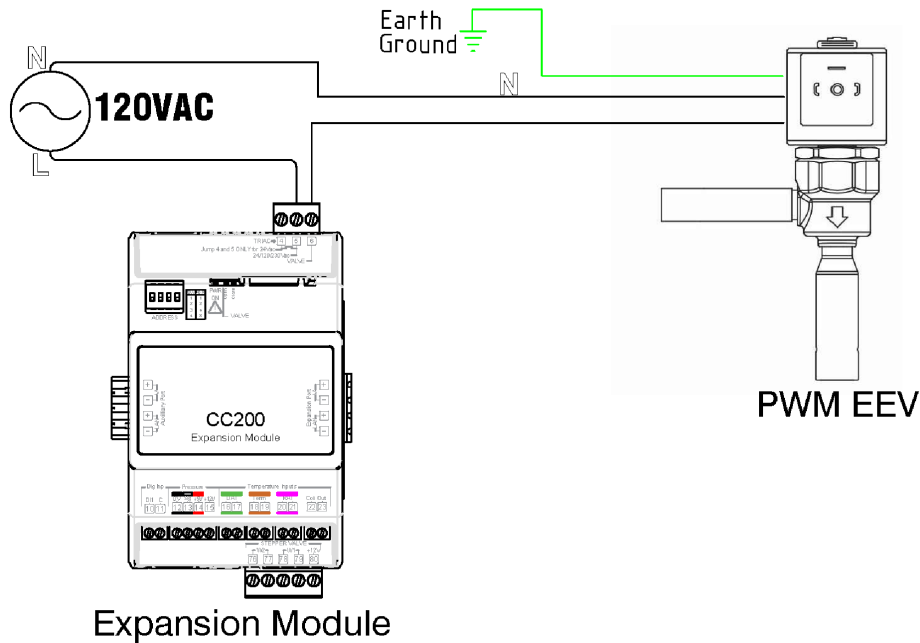

3.11 CC200 Expansion Module Mounting and Installation

Step 1: Determine if you need an Expansion Module.

- An Expansion Module should be added for a second or third coil. Each coil will have temp sensors and a transducer and will be wired to the respective Expansion Module.

Step 2: Addressing the Expansion Module.

- Set the address of each Expansion Module using the ON/OFF dip switch bank on the top left corner of the hardware.
- Expansion Module one must be set to address 1 (Position 1 up), Expansion Module two to address 2 (Position 2 up), Expansion Module three to address 3 (Position 1 and 2 up).

Step 3: Install the Expansion Module.

- Make sure power is OFF to the CC200 Main Controller. Power will be restored in a later step.
- Install Expansion Module 1 on the DIN rail adjacent to the CC200's right side. The CC200 Expansion port terminals V+, V-, LAN+ and LAN- will be aligned with Expansion Module 1 Expansion port terminals. Slide the Expansion Module into the CC200 Expansion port so both device's Expansion port connectors fasten together.
- If Expansion Modules 2 and 3 are present, connect to Expansion Module 1's Expansion port using in the same manner described in the above step.

No wiring is needed between the CC200 Main Controller and CC200 Expansion Module. Power and communication are sourced from the CC200 Expansion port and passed through each Expansion Module Expansion port.

Step 4: Terminate sensors on the Expansion Module and refer to the drawing and specifications above for terminal numbers and how to terminate.

- Once all sensor terminations are complete and the Expansion Module Expansion port is securely plugged into the CC200 Expansion port, restore the 24VDC supply power to the CC200 Main Controller. Once connected, the Expansion Module PWR ON LED will illuminate green indicating supply power is present.

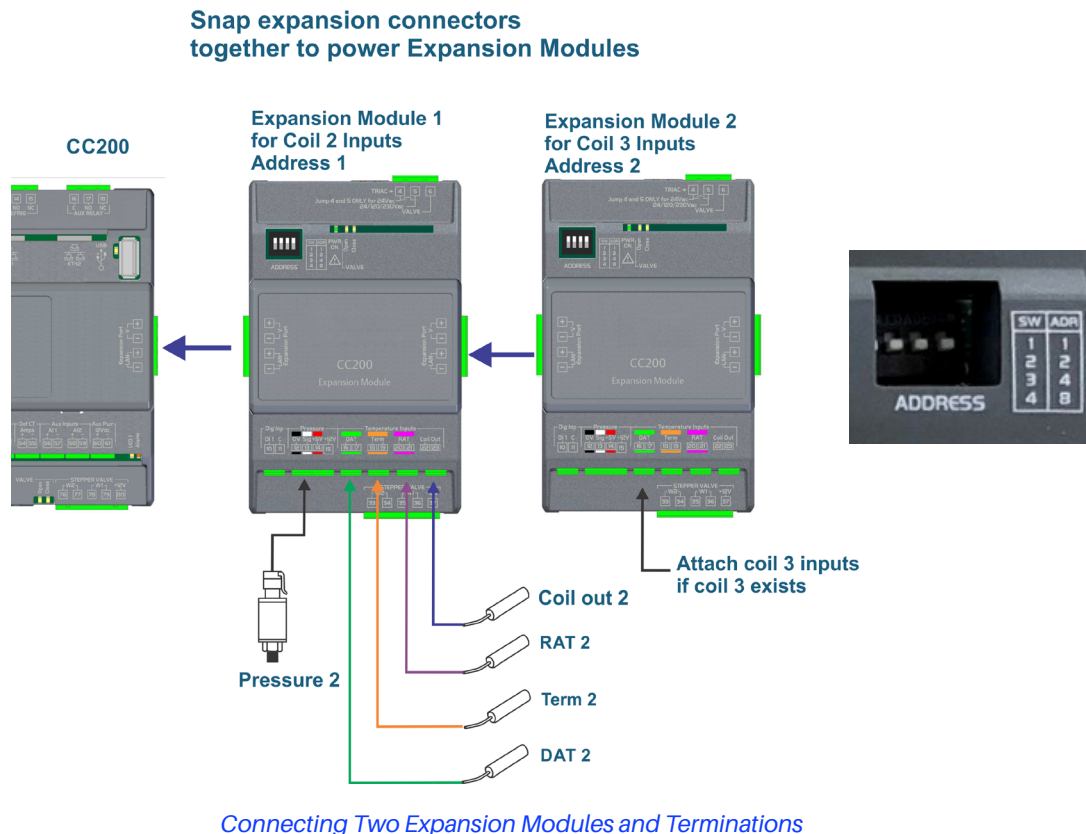

CC200 Expansion Module Specifications

CC200 Label	Description	Terminals and Color
DAT	Discharge Air	16 - 17 Green
TERM	Defrost Termination	18 - 19 Orange
RAT	Return Air	20 - 21 Purple
COIL OUT	Coil Out	22 - 23
PRESSURE	100lb, 150lb, 200lb, and 300lb Pressure Transducer Polarity Sensitive	12(0v) - 13(Sig) - 14(+5V) Black - White - Red

Wire Specs for Extending Inputs and Valves

Analog Temp Sensors or Digital Inputs	General Cable 92454A Copeland P/N 135-0600 or Belden 8761 Copeland P/N 035-0002 or equivalent 2 conductor shielded 22 AWG or larger cable may be used to extend length to a maximum of 50 ft . <u>If manufacturer harness must be extended, join wires with heat shrink and solder.</u>
Pressure Transducer	Belden 28326AS Copeland P/N 135-2832 or Belden 8771 Copeland P/N 135-8771 or equivalent 3 conductor shielded 22 AWG or larger cable may be used to extend length to a maximum of 50 ft . <u>If manufacturer harness must be extended, join wires with heat shrink and solder.</u>
EEV Stepper	Use the manufacturer harness with a maximum length not to exceed 40 ft (12 meters).
EEPR Stepper (Bipolar) EEV Stepper (Bipolar Walk-in applications)	Belden 28326AS Copeland P/N 135-2832 or Belden 9418 Copeland P/N 135-9418 or equivalent 4 conductor shielded 18 AWG or larger cable may be used to extend length to a maximum of 75 ft . <u>If manufacturer harness must be extended, join wires with heat shrink and solder.</u>

3.12 CC200 Case Display Wiring

The CC200 Case Display connection to the Case Controller is made with three (3) wire-cable from the CC200 Case Display port Terminals **27, 28, 29** labeled **Remote Display** to the **CC200 Case Display** terminals **3, 4 and 5** on the back of the display. The wire type used for this connection must be Belden #8771 3C20AWG or Belden #8772 3C20AWG or equivalent. Keep cable length at 50ft or less. Shield must not be connected to any terminal or earth ground (just inside the cable). Clip shield at both ends of cable and insulate with heat shrink.

⚠ ATTENTION

Special care should be taken when making this connection so that no wires are incorrectly landed or crossed. Miswiring in this connection likely will result in damage to the Case Display and/or Main Controller.

Step 1: Make sure power to the CC200 Main Controller is turned OFF.

Step 2: Make termination from the CC200 Main Controller to the CC200 Display.

- It is critical that these terminations are made correctly as this can result in damage to both devices if not terminated correctly.
- Clip and insulate shield at both ends of the Belden connection cable. Keep cable length at less than 50 ft (15 meters).

Step 3: Power ON the CC200 Main Controller.

Step 4: If supply power has been wired properly, the display will boot up and illuminate all icons. The display will briefly show the characters **SYn** before showing the temperature readout. If a value of **Err** is shown, it simply means the air sensor is not wired to the CC200 yet or is disconnected. A value of **noL** on the display indicates no communication, check the wiring between CC200 and the display and try again.

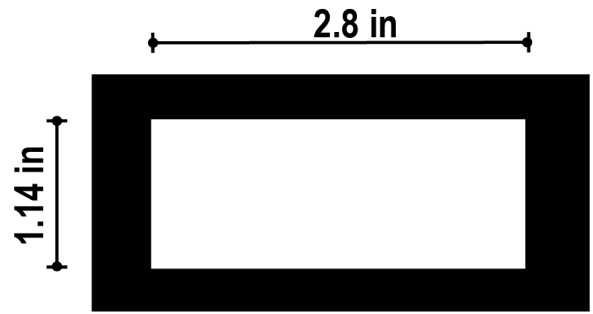
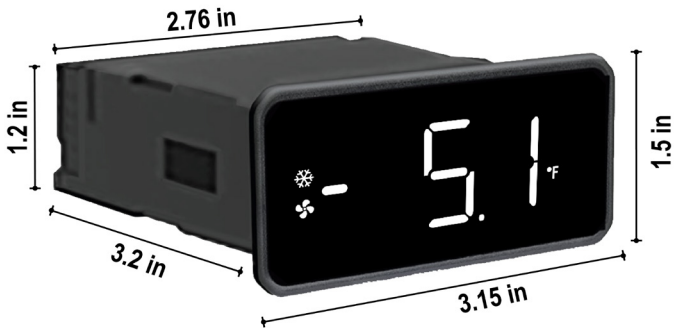

CC200 Case Display Dimensions

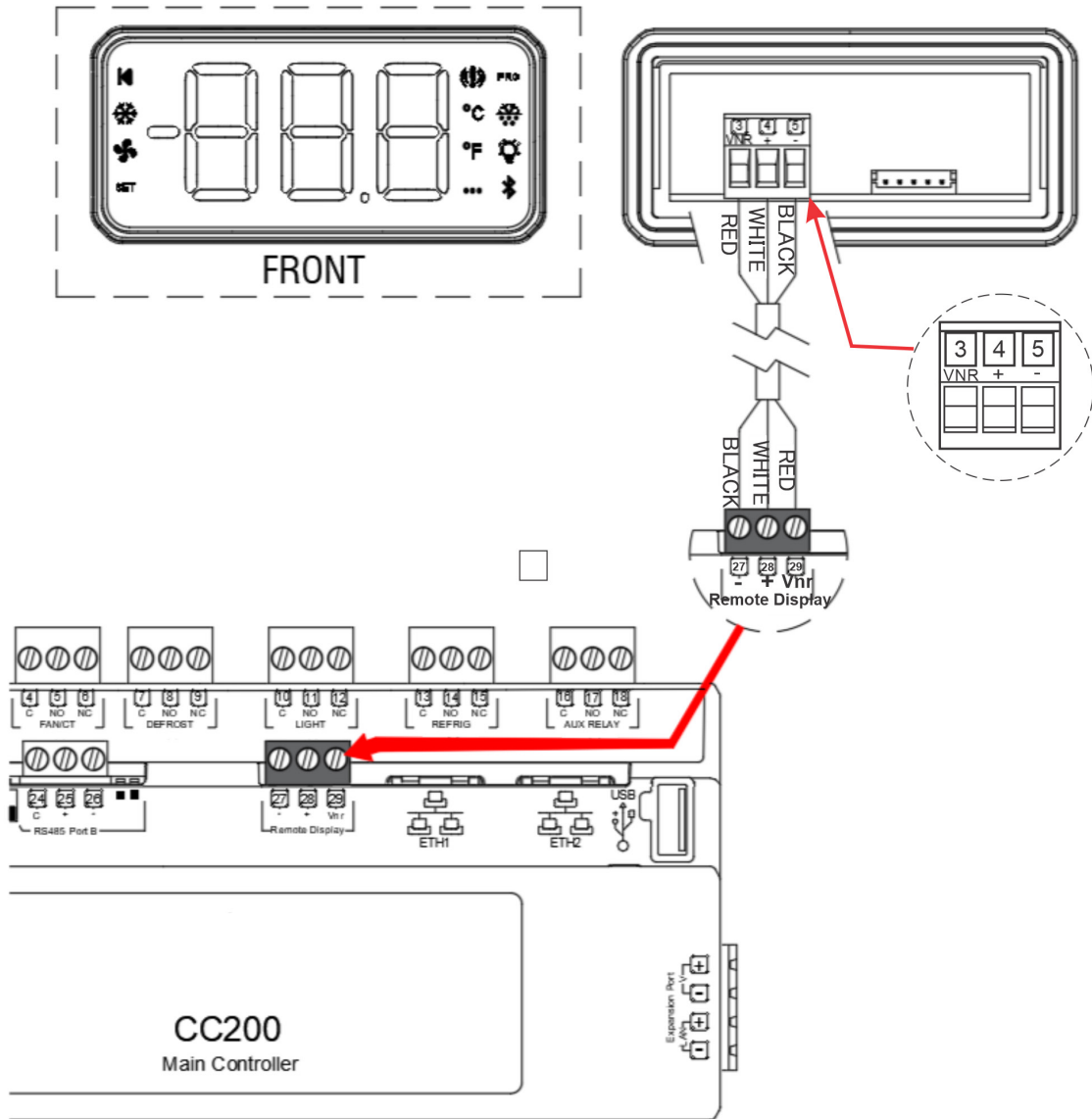

CC200 Case Display Wiring

4. Control Logic Overview

4.1 Temperature Regulation

CC200 precisely controls air temperature to setpoint using either the discharge air or return air sensor as the control sensor. For multi-coil cases with more than one air temperature, a combination method of minimum, maximum, or average is applied to calculate the final control value. CC200 has parameters that inform the controller what equipment and valves are present and based on these selections CC200 will use the optimum regulation strategy to control the evaporator and air temperature. Set the parameter COMPRESSION TYPE, EXP. VALVE TYPE, EPR TYPE and LLSV PRESENT to define all the valves and compression types used in the system.

4.2 Refrigeration Specific Controls

4.2.1 R744 (CO₂)

System Overview

CC200 versions 1.01F01 and later support R744 (CO₂) refrigerant. The CC200 is equipped to work with CO₂ Suction Groups in the E3 Supervisory Control or E2E. The CC200 CO₂ LOAD ENABLE software input seamlessly connects to the E3 or E2E Suction Group so that staggered partial load startup and emergency shutdown of CO₂ case controllers is performed properly every time.

For CO₂ installations where E3 or E2E are not present, the CC200 has standalone capability to start and stop in case of a CO₂ system high pressure event. CC200 uses a high-pressure shutdown parameter (HPS THRESHOLD) and alarm delay (HPS ALARM DELAY) to determine when to shut refrigeration down. The evaporator suction pressure transducer is monitored for pressures above the high-pressure threshold parameter. Once the pressure remains above the threshold and the delay timer expires, the CC200 will enter the Off-CO₂ High PSI state. While in the Off-CO₂ High PSI state, refrigeration will cease until the pressure falls below the HPS THRESHOLD and the restart delay timer expires. By setting increasing time values across refrigeration circuits for the HPS RESTART DELAY, a staggered case controller startup can be achieved.

Superheat Optimization (Overfeed)

CC200 versions 1.02F01 and later have support for ultra low superheat evaporators in specially designed CO₂ systems. Superheat optimization allows CC200 to be used with a specific CO₂ system design technique where medium temperature evaporators achieve near zero superheat by flooding the evaporator intentionally.

This ultra low superheat operation is typically only used in a specific CO₂ system design where a dedicated liquid vessel is present in the MT suction piping of the CO₂ system to collect excess liquid from the flooding MT evaporators. Excess liquid in the tank is distributed back into LT liquid lines where it will enter LT evaporator expansion valves. Use of CC200 superheat optimization on piping configurations or design techniques that are not recommended by evaporator and rack system manufacturers is not recommended or supported by Copeland.

To activate and use the superheat optimization feature:

- E2, E3 or Site Supervisor Controller must be installed with a communication network established to CC200 (BACnet or Modbus)
- The Supervisory Controller must be configured to provide a superheat optimization signal to the applicable CC200s via network communication
- Refrigerant parameter must be set to R744
- Superheat Optimize Setpoint must be configured, typical values are 1-3° DDF
- Superheat Optimize Ramp must be configured. Default value of 60 seconds may be sufficient but can be increased to reduce any perceived EEV control instability
- Superheat Setpoint must be configured to the evaporator OEM data sheet

The Superheat Optimization signal from the Supervisory Controller instructs the CC200 when to switch from the normal superheat setpoint to the superheat optimize setpoint value. (typically 1-2° DDF). When this setpoint shift occurs, CC200 will gradually ramp down from **Superheat Setpoint** to **Superheat Optimize Setpoint** over the duration of time specified in the Superheat Optimize Ramp parameter. If the software pointer in the DSC or ADF is switched off, then the setpoint ramp happens from **Superheat Optimize Setpoint** back up to **Superheat Setpoint**.

When Superheat Optimization is active, please note the following:

- The E2, E3, Site Supervisor, and Cold Chain Connect Mobile App will all show the CC200 operation mode as SH Optimization.
- Low superheat alarms will be disabled.

In the event the supervisory controller is offline, the CC200 will terminate Superheat Optimization and the superheat setpoint will ramp back to the standard setpoint.

4.2.2 A2L Refrigerants

CC200 versions 1.03F01 and later supports the following A2L Refrigerants: R-454C, R-455A, R-457A, R-1234YF, R-1234ZE.

A2L Sensor

When any of the A2L refrigerants is selected the RS485 PORT A port will start communicating with the connected A2L refrigerant leak sensor.

UL 60335-2-89 approval pending

A2L Refrigerant Leak Notification

Users can set an A2L Warning Limit and an A2L Alarm Limit.

When the leak sensor reports a %LFL value at or above the A2L Warning Limit for a short delay, an A2L leak warning will occur. This is an informational warning and can be disabled by setting the A2L Warning Limit to 0 %LFL. The A2L leak warning will automatically reset after a short delay when the sensor reports a value below the A2L Warning Limit.

When the leak sensor reports a %LFL value at or above the A2L Alarm Limit for a short delay, an A2L leak shutdown will occur. To reset the A2L leak alarm and shutdown, the sensor must report a %LFL value below the A2L Alarm Limit for five minutes and an A2L Alarm Reset command must be sent (either a configured momentary push button or a command from the supervisor).

A2L Leak Mitigation Strategy

A case shutdown due to an A2L leak will be similar to a normal case shutdown except for the following: The fans will remain on at full speed and the isolation valves will be activated.

4.3 Superheat Regulation

CC200 precisely controls evaporator superheat (SH) for up to three coils in a single refrigerated case or walk-in box. When the expansion valve type parameter is set to PWM EEV or Stepper EEV, the CC200 will begin regulating superheat by positioning the selected valve type. Refer to [Section 3.6, EEV and EEPR Location](#) to determine where to connect each type of expansion valve. The superheat is measured using the coil outlet sensor and a dew point temperature conversion of the connected Copeland pressure transducer. The refrigerant type selection is made with the parameter Refrigerant in the System Setup group. The algorithm uses one superheat setpoint for all three coils if present. The superheat is regulated to the superheat setpoint with a +/- half dead band zone, the parameters superheat setpoint and superheat deadband can be found in the setpoints group.

For multi-coil refrigerated case designs, CC200 supports pressure transducer installations of one transducer per coil, or one per case. When the pressure configuration parameter is set to 1 per case, CC200 will use the single pressure value in the superheat calculation for all coils. A coil outlet sensor is required on every coil.

CC200 supports superheat monitoring for TEV systems when the expansion valve type parameter is set to TEV SH. In this mode the CC200 uses the connected coil outlet sensor and pressure transducer to monitor the superheat of each evaporator in the case or walk-in box.

4.4 Dual Temperature Cases

Dual temperature cases are supported with separate setpoints for low and medium temperature applications. The CC200 will run in low temperature mode until the dual temperature digital input switch is true. When the dual temperature digital input is true, CC200 shifts to run in medium temperature mode, regulating air temperature to the medium temperature setpoint. If there is no digital input configured as a dual temperature switch, a network input is used from a Supervisor Controller. When CC200 detects the network input for dual temperature is true, the air temperature control is switched to medium temperature mode. EEPR logic automatically shifts between low and medium temperature pressure setpoints when CC200 is in dual temperature mode.

4.5 Case Lineup Management

When refrigerated cases are piped in a circuit and share common liquid and suction piping, a lineup is present, CC200 supports peer to peer communication with up to 8 cases in a single lineup (1 parent case and 7 child cases). The onboard ETH1 and ETH2 RJ45 ports and case to case Ethernet daisy chain wiring provides the connection for this communication to take place. Ethernet CAT5e cable between CC200s in a refrigeration lineup is required for all CC200 installations. See the Modbus or BACnet section for wiring details. CC200 case lineup communication involves one case designated as the lineup parent case and all other cases are lineup child cases. CC200 lineup communication allows the controller to seamlessly coordinate defrost, gather temperature data, and use sensor redundancy strategies to keep the system running longer in case of control sensor failures. Typically in a supermarket refrigeration system cases in a lineup defrost at the same time, CC200 case lineup communication is used to coordinate this task efficiently. Configuration of the lineup is performed automatically when the rack ID, lineup ID, case ID and number of cases in lineup parameters are set. The case designated with case ID "a" will automatically detect its peers in the lineup for communication.

4.6 Defrost Control

CC200 supports electric and off cycle defrost types and manages the entire defrost cycle with no control from a Supervisory Controller required. The onboard form C defrost relay can be used to switch a defrost heater for electric defrost types. Defrost heater amperage can be monitored using the Def CT analog input and a connected CT. A defrost cycle can begin via scheduled start time or through a manual defrost command. The defrost schedule uses a start time and number of cycles parameter, the defrost cycles are spaced evenly through a 24-hour period based on these two parameters. For example: with a start time of 0:00 and 4 cycles per day, the CC200 would enter defrost at 0:00, 6:00, 12:00 and 18:00.

4.6.1 Manual Defrost

Manual and emergency defrost cycles for service purposes are provided, a manual or emergency defrost can be started from the Supervisor Controller, the case display or the CC200 Cold Chain Connect mobile app (see [Section 9, Cold Chain Connect Mobile Application](#)). A manual defrost puts CC200 into a defrost cycle that will terminate normally as a scheduled defrost would. An emergency defrost runs the defrost cycle for the maximum time allowed and will not attempt to terminate early on temperature.

4.6.2 Pump Down

An optional evaporator pump down procedure to remove refrigerant from the coil may be configured via parameter settings. If the pump down duration is set to 0, no pump down procedure will be performed. During a pump down procedure, the LLSV is closed first while EEV's and EEPR remain open. After the pump down time expires, the EEV's and EEPR move to the close position for defrost. If there is no LLSV present, the EEV's close at the start of pump down.

4.6.3 Termination

If a case lineup is configured, the defrost and termination of all cases on the lineup is synchronized so that all cases enter defrost at the same time and resume refrigeration at the same time. Cases may terminate their defrost cycle individually but can only resume refrigeration once all cases have terminated or timed out. Once a case in a lineup terminates defrost, the case enters wait mode until all cases on the lineup terminate or timeout.

Termination can be time, temperature or digital input based. No matter which termination method is selected, no case can defrost longer than the maximum time.

4.7 Demand Defrost Control

CC200 Version 1.02F01 and later has support for the Demand Defrost feature for use on walk in box evaporators. Demand Defrost enables the CC200 to operate a defrost strategy capable of adapting to the wide range of environmental factors encountered in most supermarkets. Defrosting too frequently or for too long can impact product quality and system efficiency. Not defrosting enough during periods of heavy traffic, tough temperature or humidity conditions, and during increased product loading can contribute to excessive frost formation beyond what a schedule based approach can handle. CC200 Demand defrost will monitor evaporator conditions and decide when a defrost cycle is needed.

To enable the demand defrost feature, set the **Demand Defrost Enable** parameter in the defrost group to enabled. Setup the defrost **Start Time** and **Cycles Per Day** just in case a failsafe condition is reached and CC200 needs to revert back to schedule based defrost. Once demand defrost is enabled CC200 will wait for the first schedule based defrost or a manual defrost to complete, whichever occurs first. After the initial defrost cycle completes CC200 enters a learning phase where evaporator data is collected, stored and analyzed. CC200 continuously monitors evaporator conditions and connected sensors to compare to the learned data, once a defrost cycle is needed CC200 initiates a demand defrost cycle. Termination methods selected in the defrost parameters are followed. Once the demand defrost is initiated the CC200 follows the normal defrost sequence of operations for pump down, defrost, drip time, termination and fan delay as outlined in this document. Once a demand defrost terminates, CC200 continues collecting data, analyzing and comparing to determine when the next defrost should be initiated.

The parameter **Max Time Without Demand Defrost** in the defrost group is a safeguard to prevent the evaporator from running for an unusual amount of time without a demand defrost being triggered. If the time without a defrost cycle exceeds **Max Time Without Demand Defrost**, a defrost will be triggered. CC200 will shift from demand defrost to schedule based if there is a problem with learned data due to sensor errors or if there is a CC200 power loss.

4.8 Fan Control

CC200 controls the evaporator fan motor using the onboard form C relay labeled Fan. A variety of fan control logic is supported to accommodate different systems and temperature applications. The fan during refrigeration can be set to cut in/cut out with the air temperature setpoint and deadband or be set to run continuously during refrigeration. During defrost the fan can remain on or off depending on parameter selection to accommodate different case types.

Optionally via parameter selection, the fan can be delayed after defrost to allow moisture on the coil to re-freeze. The fan can be delayed by time or temperature, the default action is time with no delay.

For service and analytics, the CC200 measures the fan motor amperage through the internal form C relay. The case controller is able to measure current for low amperage ECM type motors as well as fixed speed motor designs. The onboard fan relay can control motors up to 5 AAC, motors greater than this rating should be controlled with a pilot relay or contactor. For these larger motors CC200 supports amperage monitoring through AI1 or AI2 with a CT connected.

Two Speed and Variable Speed Fans

The optional two speed and variable speed fan control will only be enabled when the Fan During Refrigeration parameter is set to Continuous On.

Two Speed Fan

The auxiliary relay can be configured as a Fan 2 Speed output. This output will be controlled on a hysteresis based on the refrigeration control value and the refrigeration setpoint +/- half the refrigeration deadband.

Variable Speed Fan

A variable speed function can be selected for an analog output. The output has an option to be inverted so the output can scale so outputting 10V can be either the minimum fan speed or maximum fan speed.

This output will be scaled based on the refrigeration control value. When the refrigeration control value is at or below the refrigeration setpoint, the output will be set to the user selectable Fan Speed Min. As the refrigeration control value increases above the refrigeration setpoint, the fan speed will move from the Fan Speed Min setting to the Fan Speed Max setting. When the refrigeration control value reaches the refrigeration setpoint + refrigeration deadband the output will be limited to the Fan Speed Max setting.

4.9 Electric Evaporator Pressure Regulator (EEPR)

CC200 can manage an EEPR for regulating air temperature and evaporator pressure. Two control modes are available, discharge air or pressure. In air temperature mode, the valve will be regulated to maintain air temperature to setpoint. In air temperature mode when a case lineup is present, the lineup parent case will gather all available air sensor values from all CC200s in the lineup. The lineup parent case will perform a combination method on the available sensors; the combination method is selectable via parameter selection with options of average, minimum and maximum. Any sensors that are in error will be automatically discarded from the combined control value.

4.9.1 Pressure Mode

In pressure mode, the suction pressure is converted to a saturated suction temperature (SST) and the valve is regulated to maintain precise SST control to the active SST setpoint. The saturated conversion method is selectable via the parameter with options of: dew point, midpoint, bubble point or a weighted average of 60% dew/40% bubble. The refrigerant parameter for refrigerant selection determines the refrigerant gas used for SST calculation. For dual temperature cases a low and medium temperature SST setpoint are provided. CC200 will automatically shift between the low and medium temperature setpoints whenever a dual temperature shift is required.

4.9.2 Floating SST Algorithm

CC200 utilizes a floating saturated suction temperature algorithm to automatically tune the SST to an optimal setpoint for air temperature control.

Many refrigerant blends have a high temperature glide, as a result running the evaporator at the design saturated temperature can result in discharge air temperatures that are lower or higher than desired.

CC200 deploys an algorithm that makes tiny incremental adjustments to the SST setpoint over time in order to tune discharge air temperatures to the target setpoint. The algorithm constantly analyzes air temperature data to determine if an adjustment is needed. Once air temperature is on target, the SST setpoint is saved as the new operational setpoint. To enable the floating algorithm, set the float band parameter to a value greater than 0. A value of 4°F is suggested as a starting value. The float band parameter defines the amount of adjustment allowed above and below the SST setpoint. For example, an SST setpoint of -10° with a float band of 4° will allow the algorithm to adjust the SST setpoint from -12° to -8°.

4.9.3 Sensor Redundancy

In pressure mode, the EEPR control logic uses pressure 1 as the input, if pressure 1 is in error the CC200 automatically falls back to pressure 2 if available, then pressure 3. If no local pressure sensors are available and there is a lineup CC200 will search the available pressure sensors from lineup child cases to find a back up sensor for control. Once the primary control input failure is restored, CC200 automatically switches back. If there are no pressure sensors available onboard or throughout the lineup, CC200 will automatically fall back to discharge air mode on the EEPR in order to maintain food safety. If there are no pressure or discharge air sensors available with valid readings then CC200 will position the EEPR at the 24-hour refrigeration average.

4.10 Lighting Control

CC200 supports multiple lighting control options to accommodate different customer lighting strategies. The lights are controlled from the onboard form C relay labeled Light. The control mode is selectable via parameter, the options are DI Triggers, Schedule w/ Dimming, Supervisor w/ Dimming, Local Schedule Only, Supervisor Control.

When DI Triggers mode is selected the lights will switch on by a motion sensor digital input or a walk-in box door switch. When the digital input is active, the lights switch on for a specified amount of time before turning off again. The time delay is adjustable via parameter.

When Schedule w/Dimming is selected the lights will be controlled based on the CC200 schedule on and schedule off parameters. During scheduled off hours the lights will be completely off and will not dim, ramp up or down. During schedule-on hours, the lights will remain dim until the motion sensor detects movement. Once motion is detected, the lights ramp up from minimum dimming level to maximum dimming level. After 5 minutes with no motion detected the lights ramp from maximum dimming level to minimum dimming level and remain there until motion is detected again.

Supervisor w/Dimming deploys the exact same logic as Schedule w/Dimming but instead of the local schedule, the supervisor directly controls the light relay with its own schedule. During scheduled on hours dimming is allowed, during scheduled-off hours, no dimming is allowed.

Supervisor control allows the light relay to be directly controlled by the Supervisor Controller with no dimming or motion sensor logic. If the supervisor is offline, the CC200 falls back to its local schedule to control the light relay.

4.11 Door Switch

CC200 supports a door switch for walk-in box door opening detection. A door switch must be configured on one of the available digital inputs on CC200 or the CC200 expansion module. See appendix at the end of this document for Door Switch Mounting and Wiring. The door switch can be used to turn refrigeration and fans off during door opening events. This feature is configurable via parameter, when activated the liquid line solenoid and fan relay outputs will be turned off during door openings. Once the door closes the relays will become active again; there is a failsafe timeout parameter to return the relays to on. If the door remains open longer than the failsafe time, the fan and LLSV automatically become active again.

The door switch can also be used to switch the lights on, this feature can be enabled/disabled via parameter. When enabled, the lights turn on with every door opening for the amount of time defined by a parameter.

4.12 Shutdown Modes

Service Shutdown

For cleaning and service convenience the CC200 supports a service shutdown feature. This can be activated from the case display, Supervisor Controller, Cold Chain Connect mobile application or a physical switch. When a service shutdown is active all relays will immediately turn off and all valves will close, and all control logic will be suspended. The default timer for shutdown is 60 minutes, after the timer expires the case resumes refrigeration again.

Refrigerant Leak Shutdown

CC200 supports a specific refrigeration leak shutdown to disable refrigeration in the event of a refrigeration leak event. The leak shutdown can be triggered by a physical digital input or from a Supervisor Controller over the communication network. When a leak shutdown is active, the system will shut down and perform a pump down if the pump down time is greater than 0. If a leak shutdown is initiated by a Supervisor Controller, the shutdown will persist through CC200 reboots. The leak shutdown will end once the Supervisor Controller removes it and the digital input function is inactive (if configured).

Night Shutdown

The night shutdown feature requires a supervisor to be online.

A night shutdown acts like a normal shutdown except the fans stay on at minimum speed. The fan relay output will remain on, but the auxiliary fan 2 speed output will be deactivated and the variable speed analog output will go to its minimum speed.

A2L Shutdown

An A2L Shutdown is triggered when an A2L refrigerant leak exceeds a threshold. See [Section 4.2.2, A2L Refrigerants](#) for additional information.

4.13 Analog Inputs

CC200 Main Controller has a combination of fixed function and auxiliary analog inputs onboard. The CC200 expansion module has only fixed function inputs. The fixed function inputs are labeled with a name on the controller enclosures and do not have software-selectable functions. The engineering unit range of the pressure transducers is selectable via the CC200 parameter. The purpose of each fixed function input is described below:

Enclosure Level	Purpose
Pressure 0V, Sig, +5v	Pressure transducer connection, .5-4.5VDC software selectable EU range 100 PSI, 150 PSI, 200 PSI, 300 PSI.
DAT	Discharge air temperature sensor connection, non-polarity sensitive.
Term	Defrost termination temperature sensor connection, non-polarity sensitive.
RAT	Return air temperature sensor connection, non-polarity sensitive.
Coil Out	Coil outlet temperature sensor connection, non-polarity sensitive.

The CC200 Main Controller has Aux Inputs AI1 and AI2 with a software-selectable function. Each input has identical options, described in the table below:

Function Option	Purpose
Fan CT	For connection of current transducer for evaporator fan motor amperage monitoring and alarming. Used when fan motor amperage is greater than the 5 amps limit for the onboard CT on the CC200 fan relay.
Coil Inlet	Evaporator coil inlet temperature sensor. Mounted after expansion valve outlet for Coil Out-Coil In superheat calculation.
Product Temperature	Product temperature sensor for product temperature monitoring and alarming.
Circuit Suction Temperature	Circuit suction temperature sensor for overall circuit lineup superheat monitoring and alarming.

All input sensors have an option to enter a sensor value offset via parameter settings.

4.14 Digital Inputs

The CC200 The CC200 main controller has four selectable function voltage free (dry contact) digital inputs on terminals 31-38. The CC200 Expansion Module has one selectable function potential free digital input on terminals 10-11. All selectable function digital inputs have the following function options:

Function Option	Purpose
Door Switch	Door switch for walk-in box door opening detection.
Service Shutdown	Shutdown switch for service shutdown activation/de-activation.
Dual Temperature	Dual temperature switch for switching dual temperature cases between low and medium setpoints.
Defrost Termination	Defrost termination signal, terminates defrost when true.
Motion Sensor	Motion sensor for lighting control.
Leak Shutdown	Refrigerant leak shutdown, activates/de-activates a leak shutdown.
Satellite 1	Satellite 1 for E2E, acts as a spare digital input and reports value to E2E.
Satellite 2	Satellite 2 for E2E, acts as a spare digital input and reports value to E2E.
Reset A2L Alarm	Input from a physical momentary push button for resetting an A2L Leak Alarm after the %LFL has remained below the A2L Alarm Limit for at least five minutes.

Each digital input function has a companion parameter called active state. Active state determines what physical state of the digital input contacts results in a logical true for CC200 control logic.

Example:

Physical Contact	Active State	Logical Result
Close	Close	TRUE/ON
Close	Open	FALSE/OFF
Open	Close	FALSE/OFF
Open	Open	TRUE/ON

4.15 Relay Outputs

The CC200 Main Controller has four fixed-function form C relay outputs and one auxiliary form C relay output with selectable functions. The function of each fixed function relay output is described below:

Enclosure Label	Purpose
FAN/CT	Evaporator fan motor control with internal current transducer for amperage monitoring.
DEFROST	Defrost heater control.
LIGHT	Case/walk in box lighting control.
REFRIG	Refrigeration liquid line solenoid valve (LLSV).

The relay labeled AUX RELAY on the enclosure is an auxiliary and has selectable functions.

All relay functions have an associated active state parameter that determines if the relay should be energized or de-energized to turn on the connected load.

4.16 Alarms

CC200 tracks multiple alarm conditions in the refrigerated case/walk in box. All alarms automatically reset when the condition is resolved, there is no manual reset or manual clearing of active alarms.

4.16.1 Analog Input Alarms

All analog input sensors have a sensor failure alarm to indicate a sensor failure. Sensor alarms will automatically be reset once the sensor reading is valid again.

4.16.2 Fan Proof Alarm

The fan motor current transducer (internal and auxiliary AI function) can be used to monitor and determine a fan motor status. When the fan relay is on and the amperage from the fan CT rises above the fan on setpoint, the fan motor status is considered ON. If the amperage falls below the on setpoint while the relay is on, the status will turn off and a fan motor command failure alarm will result. When the fan relay is off and the amperage from the fan CT falls below the off setpoint, the fan motor status will be considered off. If the fan motor status comes on while the relay is off, a fan motor command failure alarm will result.

4.16.3 Defrost Proof Alarm

When a defrost CT is configured, the defrost amperage monitoring and alarming feature can be used. When the defrost relay is on and the amperage from the defrost CT rises above the Defrost On setpoint, the defrost status is considered ON. If the amperage falls below the on setpoint while the relay is on the status will turn off and a defrost heater command failure alarm will result. When the defrost relay is off and the amperage from the defrost CT falls below the off setpoint, the defrost heater status will be considered off. If the defrost heater status comes on while the relay is off, a defrost heater command failure alarm will result.

4.16.4 Case Temperature Alarm

Case temperature alarm logic will monitor case air temperature during the refrigeration cycle to determine if there is a high or low alarm. If the air temperature in the case rises above the high case temperature setpoint or falls below the low case temperature setpoint for longer than the alarm delay, an alarm will result. The high case temperature alarming is disabled following a defrost for the duration of the delay after defrost parameter.

4.16.5 Communication Offline Alarms

Each CC200 expansion module that is configured will have an alarm condition if communication fails. The alarm will automatically reset once communication is successful again.

If a lineup is present, the lineup parent case (designated by case ID "a") will monitor each of its configured child cases for communication, if any child case falls offline the parent case will generate a child case offline alarm. The alarm will reset once successful communication is restored.

The lineup child cases will monitor communication from the lineup parent case and if an offline condition is detected a parent case offline alarm will result. The alarm will reset once successful communication is restored.

CC200 will monitor communication from the Supervisor Controller (if connected), if communication fails for more than two minutes a supervisor offline alarm will result. The alarm will reset once successful communication is restored.

4.16.6 Refrigerant Leak Alarm

When it is detected that there is a refrigerant leak, the CC200 will immediately shut down refrigeration with no delays. During this time, a Pump Down Procedure will occur to remove refrigerant from the coils and minimize the amount of refrigerant that can leak. This alarm will reset when the source of the refrigerant leak detection has been resolved. This alarm will persist through reboots until it is resolved.

5. CC200 Case Display

5.1 Display Overview

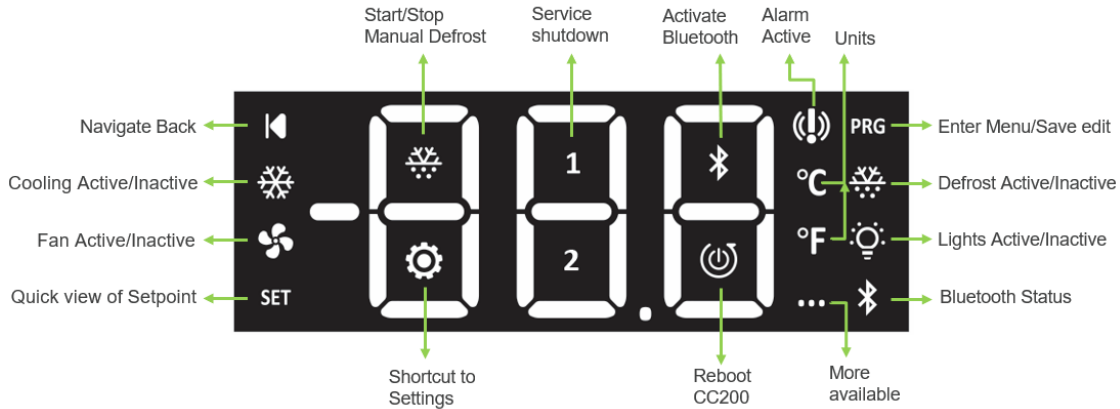

CC200 Case Display Program

The CC200 Case Display is the local user interface for the CC200 Case Controller. The display is connected to the CC200 Main Controller for supply power and communication. Status information, parameters, and service actions are available through the display. Bluetooth® connectivity can be activated using a quick action icon on the display.

When the display is locked, the main temperature screen is visible with the air temperature and unit of measure indicated. The air temperature displayed is the average of the connected discharge air or return air sensors depending on the type of control sensor selected.

The display will show the letters DEF in place of the temperature immediately following a defrost until the temperature has pulled back to down near the air temperature target.

The display will show the letters OFF in place of the temperature if there is a service or leak shutdown active from any source (Supervisory Controller, display action icon, Cold Chain Connect mobile app or digital input). OFF will be shown for the entire duration of the service shutdown.

5.2 Unlock and Parameter Edits

Unlock the display: Push and hold the upper right corner for 5 seconds and the display will beep and **PRG** and **SET** will become visible.

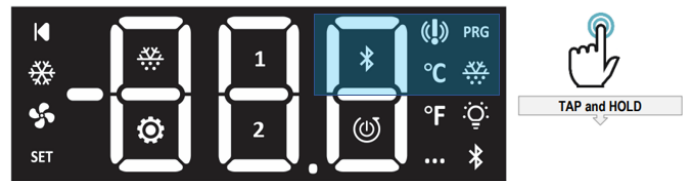

CC200 Case Display Unlock

Once unlocked, from the main temperature screen touch and hold **PRG** for 3 seconds to reach the parameter menu. PCL will be displayed for the as the first parameter group.



CC200 Case Display PRG Screen

Swipe horizontally to move between parameter groups. Tap **PRG** to enter a group and view its parameters.

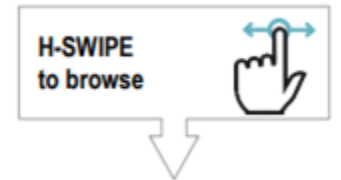

The following groups and parameters are available for editing.

Parameter Label	Description	Values
Group - PCL		
CON	Supervisor communication protocol	Nrt - Modbus RS485 BiP - BACnet IP
Group - bAC		
ADr	Address - Enter the BACnet MS/TP MAC Address of the controller	1 - 254
bAU	Baud Rate - Select the MS/TP baud rate for BACnet (router)	960 - 9600 Baud 192 - 19200 Baud 384 - 38400 Baud 576 - 57600 Baud 115 - 115200 Baud
iP1	IP Address 1st Octet - Select the value of the first octet of the IP address	1 - 254
rid	Rack ID - Select the rack system ID for the case or lineup	List
lid	Lineup ID - Select the lineup circuit number	1 - 99
cid	Case ID - Select the case letter ID	List - A to H
ciL	Cases In Lineup - Enter the number of cases in the lineup	1 - 8
NAS	Max Master - Enter the BACnet max master of the controller	1 - 127
APr	APDU Retries - Enter number of application protocol data unit retries	0 - 4
APt	APDU Timeout - Enter application protocol data unit timeout	3 - 140
NIF	Max Info Frames - Enter max frames to send per token	1 - 100
rtr	Router Enable - Select yes to enable MS/TP to IP router	No - Router disabled Yes - Router enabled
SAv	Command to saves the current edits to BACnet settings	No - Don't save Yes - Save Modbus settings and reboot
Group - NOd		
ADr	Address - Enter the Modbus address of the controller	1 - 254
bAU	Baud Rate - Select the baud rate for Modbus	960 - 9600 Baud 192 - 19200 Baud 384 - 38400 Baud 576 - 57600 Baud 115 - 115200 Baud
iP1	IP Address 1st Octet (Not used for Modbus) - Select the value of the first octet of the IP address	1 - 254
rid	Rack ID - Select the rack system ID for the case or lineup	List
lid	Lineup ID - Select the lineup circuit number	1 - 99
cid	Case ID - Select the case letter ID	List a - h
ciL	Cases In Lineup - Enter the number of cases in the lineup	1 - 8
dAt	Data Bits - Enter the number of data bits for the message	7 - 8
PAr	Parity - Select the parity type for the message	nOn - No parity odd - Odd parity EUE - Even parity
StP	Stop Bits - Enter the number of stop bits for the message	1 - 2
SAv	Save - Save Modbus settings	No - Don't save Yes - Save Modbus settings and reboot
Group - VEr		
UPd	Update Enable - Trigger display firmware download from CC200	No - Don't start the download Yes - Start the .fw download from CC200
OtP	OTAP - Enable OTAP mode (Copeland use only)	No - Disable OTAP Yes - Enable OTAP

Example: Swipe horizontally to reach **BAU**, then tap **PRG** to see the current value. Swipe up/down to edit the value.

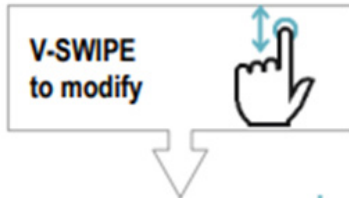

Hold **PRG** for 3 seconds to save the new value and exit. The display will beep and blink at completion of saving.

There are two parameters inside the group **VER**:

UPd	Initiate the display firmware file upgrade from CC200, set to Yes to begin.
Otp	Enter OTAP mode for over the air upgrade from the mobile app, set to Yes to begin.

5.3 Action Icons

The six action icons in the center of the display are described in the table below. All of the action icons can be reached once the display is unlocked.

Unlock the keyboard and horizontal swipe to reach the actions.



Icon	Requirement
	When no defrost is active, long press for 3 seconds to start manual defrost. During a defrost long press for 3 seconds to end manual defrost.
1	Long press for 3 seconds to enter service shutdown. Long press again for 3 seconds to exit service shutdown.
	Long press for 3 seconds to turn on Bluetooth® radio. Long press again for 3 seconds to turn off Bluetooth® radio
	Long press for 3 seconds to jump to parameter group, "BAC"
2	No function.
	Long press for 5 seconds to reboot CC200.

5.4 Status Icons

The 12 icons on the outer edge of the display are described in the table below:

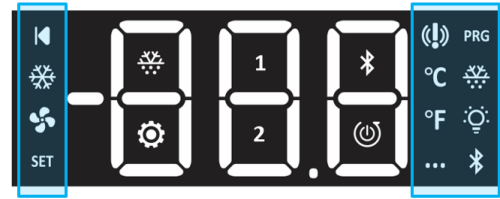

Icon	Description
	Tap to navigate back.
	Solid on if refrigeration cooling is active, off if inactive.
	Solid on if fan is active.
SET	Solid on when display is unlocked. Tap for quick access to view active air setpoint.
	Solid on when at least one alarm is active.
°C	Celsius temperature unit label.
°F	Fahrenheit temperature unit label.
...	Solid on when there are more pages/screens available to access by swiping.
PRG	Solid on when display is unlocked. Hold for 3 seconds to enter menu or save an edit.
	Solid on indicates defrost is active.
	Solid on when light output is ON.
	Blink 1 second on/off if BLE is active and ready to pair. Solid on when Bluetooth is connected.

6. The BACnet Network

6.1 MS/TP-IP Router Topology

The CC200 operates as a standalone controller, but also can be connected to a Supervisory Controller for remote access, setpoint configuration and alarming. For BACnet communication with a Supervisory Controller, the CC200 uses a BACnet router topology. CC200 version 1.03F01 or newer supports BACnet IP communication directly to E3 without the use of the router topology. For instructions on setting up BACnet IP with E3 see [Section 6.2, BACnet IP with E3 Ethernet Ports](#). This section covers the MS/TP-IP router topology, which can be used with E2E or E3.

The CC200 BACnet network always contains ONLY ONE router CC200 and a number of other non-router/BACnet IP CC200s. Any CC200 Main Controller can be enabled to be the router by setting the BACnet router enable parameter to Yes. For a BACnet network, the router is the ONLY CC200 that has its BACnet router enable parameter set to Yes and RS485 twisted pair cable terminated to it. All other CC200s on the BACnet network will be non-router/ BACnet IP devices. BACnet IP CC200s connect to the CC200 router device with a field installed CAT5e Ethernet cabling system using the onboard Ethernet switch capability built into the ETH1 and ETH2 ports of each CC200. For E2E a maximum of 32 CC200 BACnet devices per "comm loop" per supervisor serial port is allowed. A maximum total of 64 CC200 BACnet devices across all E2E serial ports is allowed. The router CC200 and all connected BACnet IP CC200s count towards the maximum.

Configuring the CC200 as a router is covered in [Section 6.5, Configuring BACnet Settings on the CC200 Case Display](#) of this manual. Each CC200 ships from the factory with the router disabled. The figure below gives an overview of the required BACnet network topology.

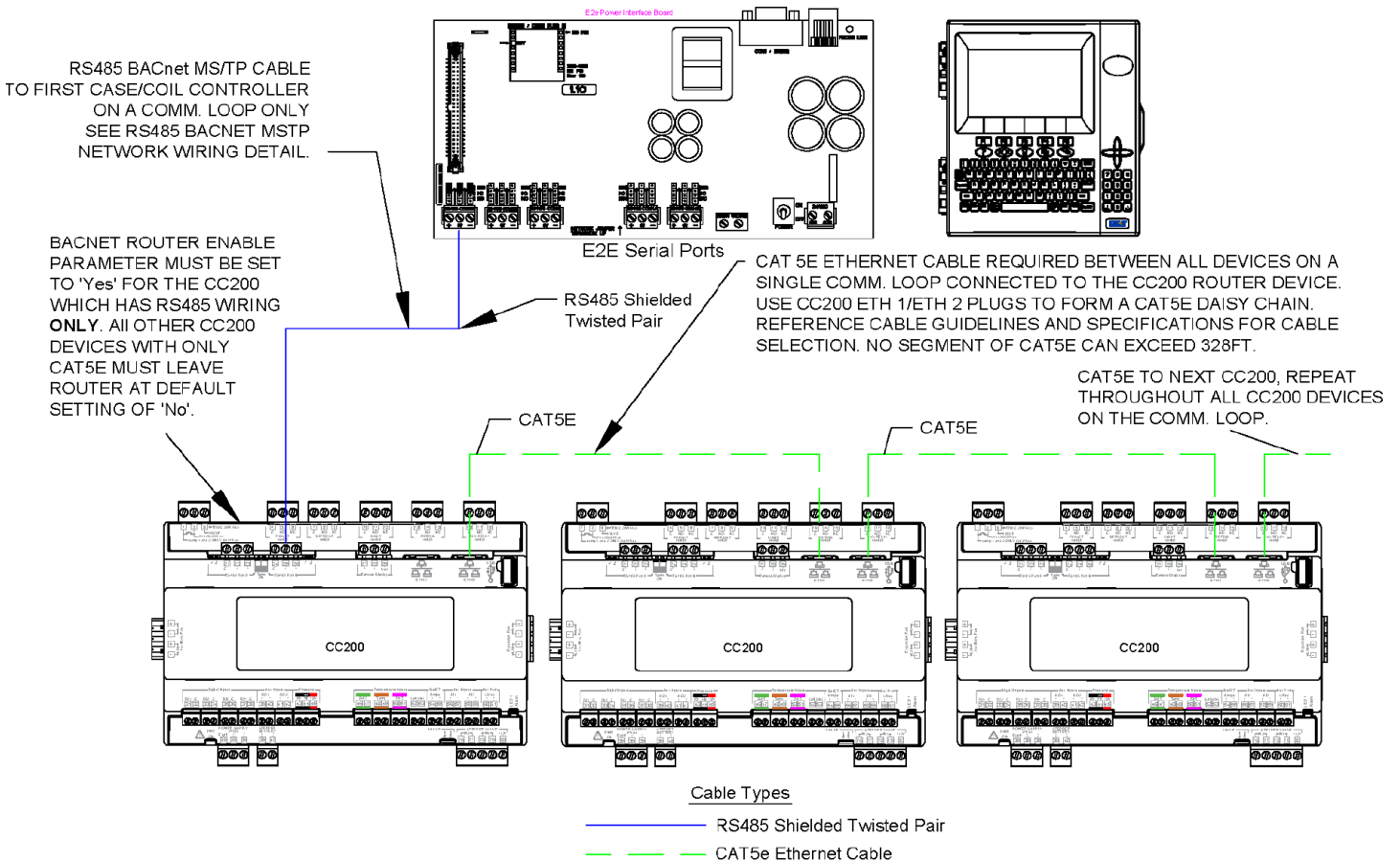

Network Topology Overview for E2

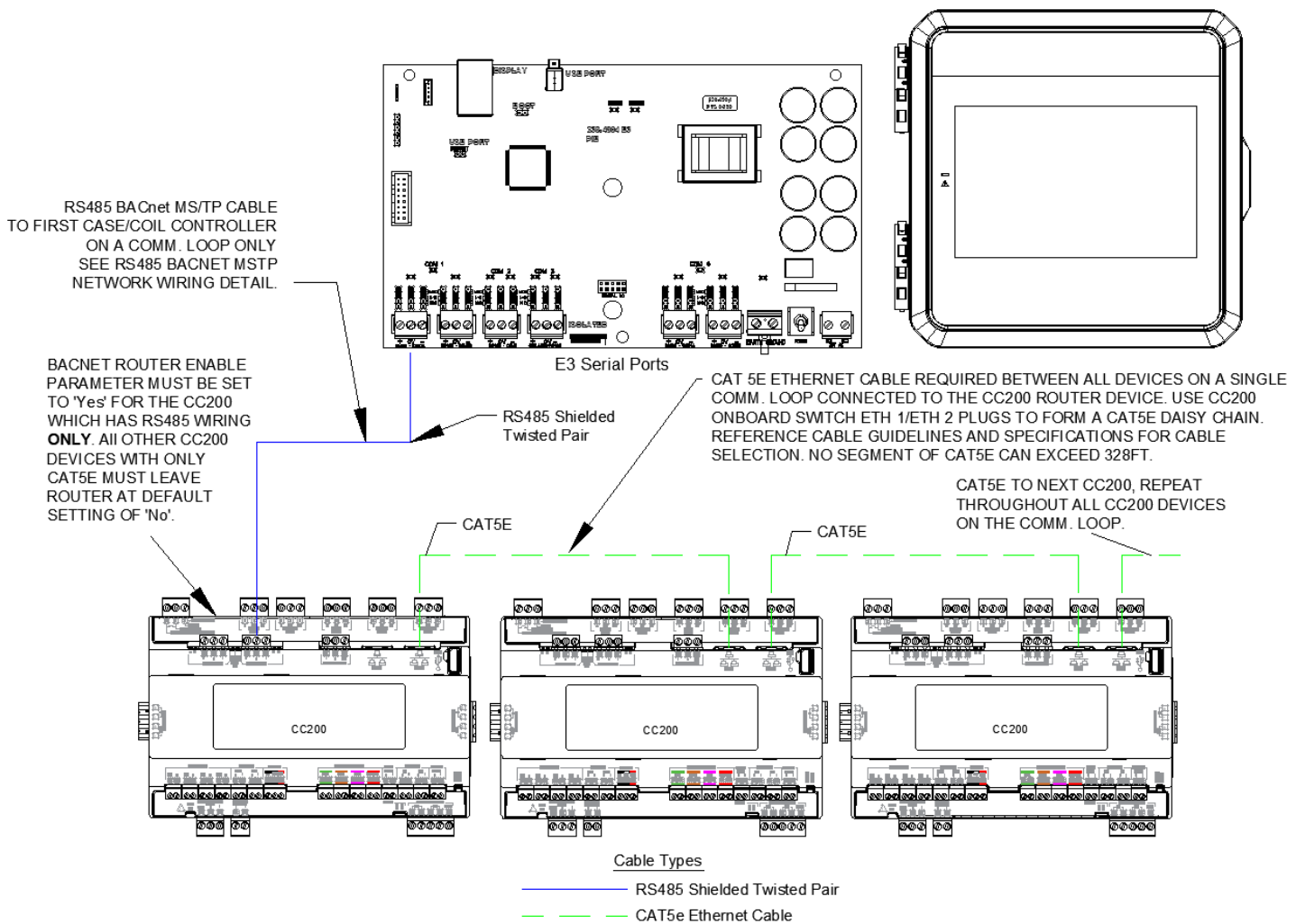

Network Topology Overview for E3

6.2 BACnet IP with E3 Ethernet Ports

CC200 version 1.03F01 or newer and E3 version 2.28F02 or later can use BACnet IP directly to the E3 ETH 1 Ethernet port. This network topology enables the speed and reliability of BACnet IP and CAT5e/CAT6 cable, and eliminates RS485 BACnet MS/TP completely. A cumulative maximum of 90 CC200 controllers from all CAT5e cable runs combined can be used on a single E3 ETH 1 port.

For successful BACnet IP communication between E3 Ethernet port 1 and CC200s to occur, all CC200 IP addresses must be in the same subnet as E3 ETH 1 and ETH 1 subnet mask and PIB network subnet mask must both be set at 255.0.0.0. CC200 subnet mask defaults to 255.0.0.0 already. Each CC200 must also have a unique BACnet device object identifier, which will be automatically assigned by following the steps in [Section 6.5, Configuring BACnet Settings on the CC200 Case Display](#).

The following guidelines must be followed when planning a CC200 BACnet IP install with E3:

- E3 running firmware 2.28F02 or newer
- All CC200s on BACnet IP network running firmware 2.28F02 or newer
- Use a quality CAT5e cable such as the recommended options suggested in recommended cable choices section of this manual
- CAT5e RJ45 crimps must be quality as described in the recommended choices section of this manual. Care should be taken to ensure good workmanship of the crimp itself.
- Any switches used to facilitate cabling runs back to E3 must be unmanaged, Non-POE type that do not block traffic on BACnet IP port 47808
- Follow instructions on setting up the E3 ETH1 port and CC200 IP address scheme in this manual. Failure to do so may cause disruption to E3 ETH0/corporate WAN connection.
- Change all BACnet IP CC200 IP address octet 1 to 192 as outlined in [Section 6.5, Configuring BACnet Settings on the CC200 Case Display](#) and [BACnet IP Devices for Connection to E3](#).

CC200 BACnet IP to E3 ETH 1 PORT

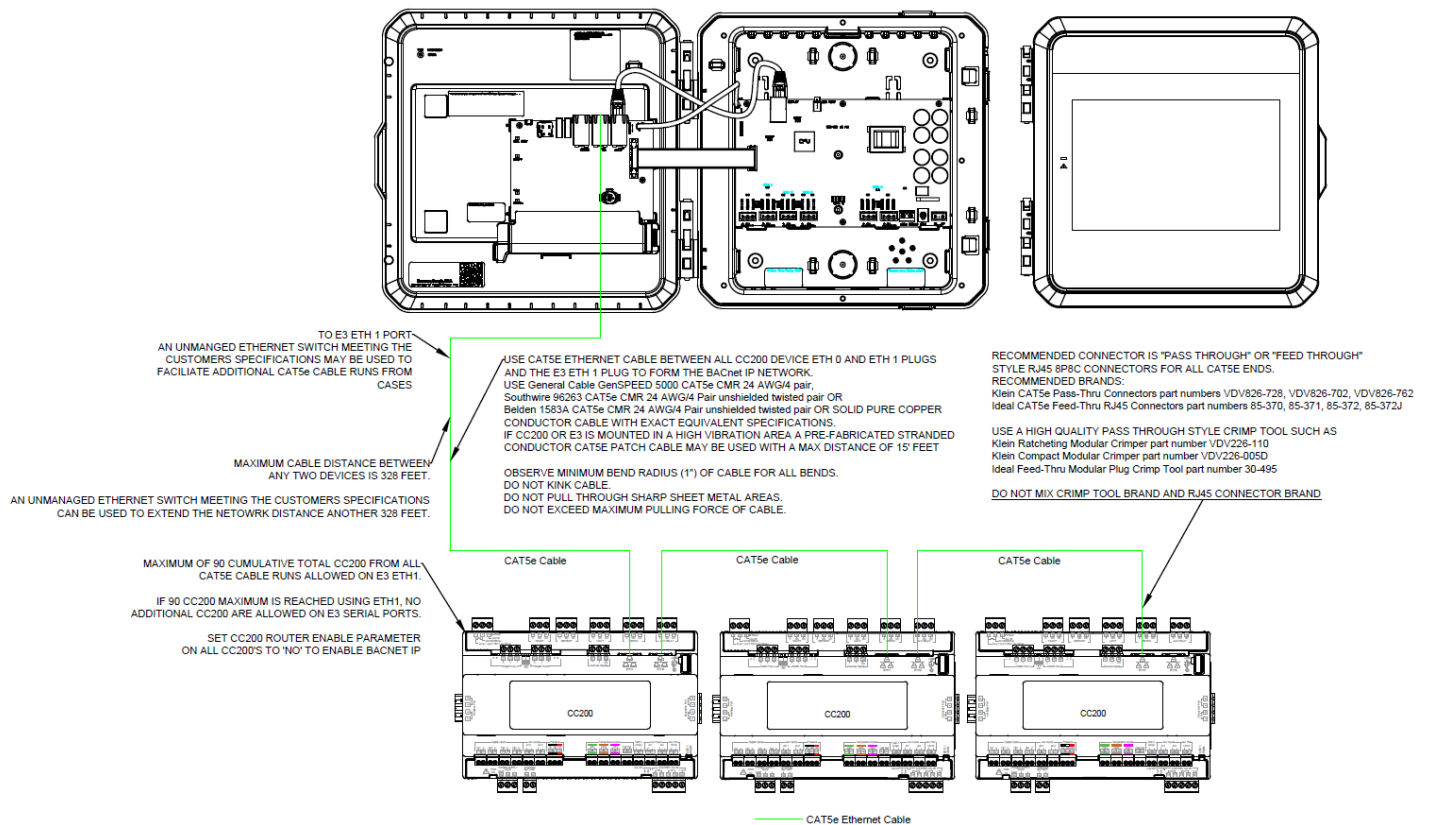

BACnet IP with E3 Ethernet Port 1 Cabling and Details

CC200 BACnet IP Ethernet Cabling

When installing a CC200 BACnet IP network, installers should strive to select cable, connectors and crimpers from the recommended choices below. If cable from the recommended choices is not readily available to the installer, a cable can be selected that meets or exceeds the required general specifications. If selecting an RJ45 (8P8C) connector outside of the recommended choices below, be sure to review the specifications of the connector and the cable chosen to ensure proper fitment. For proper cable and connector fitting, choose a connector with a specified maximum cable diameter that easily accommodates the overall outside diameter of the Ethernet cable. Additionally, ensure the connector specifications for conductor AWG accommodate the Ethernet cable AWG.

BACnet IP Ethernet Cable Recommended Cable Choices

- Copeland recommends the following cable options or an exact equivalent that meets or exceeds all of the general specifications below:
 - General Cable GenSPEED 5000 CAT5e CMR 24 AWG/4 pair unshielded twisted pair
 - Southwire 96263 CAT5e CMR 24 AWG/4 Pair unshielded twisted pair
 - Belden 1583A CAT5e CMR 24 AWG/4 Pair unshielded twisted pair

BACnet IP Ethernet Cable Recommended Connectors and Crimp Tools

NOTICE

Do not use IDEAL brand connectors with the Klein Tools brand crimp tool. Do not use Klein Tools brand connectors with the IDEAL brand crimp tool. Field installations and tests have shown that mixing connector and crimp tool brands can produce cables that pass an Ethernet cable tester, but fail when installed in the BACnet IP network.

- Pass-through or feed-through style RJ45 (8P8C) connectors must be used for all terminations on the BACnet IP network. Copeland recommends the following options for unshielded RJ45 connectors:
 - Klein CAT5e Pass-Thru Connectors part numbers VDV826-728, VDV826-702, VDV826-762
 - Ideal CAT5e Feed-Thru RJ45 Connectors part numbers 85-370, 85-371, 85-372, 85-372J
- A high quality pass through style RJ45 crimp tool must be used for all terminations on the BACnet IP network. The following options are recommended:
 - Klein Ratcheting Modular Crimper part number VDV226-110
 - Klein Compact Modular Crimper part number VDV226-005D
 - Ideal Feed-Thru Modular Plug Crimp Tool part number 30-495

BACnet IP Ethernet Cable General Specifications

- TIA /EIA CAT5e or TIA/EIA CAT6 solid pure copper conductors with wire size 24 AWG, 23 AWG, or 22 AWG. Shielded and unshielded twisted pairs cables are both acceptable.
 - CC200 cabling segment maximum length 328 feet
- If the CC200 is mounted in a high vibration environment a prefabricated stranded patch cable may be used with a maximum length of 15 feet
- At a minimum the cable must meet 100-Ohm Balanced Twisted-Pair Cabling Standard ANSI/TIA/EIA-568-B.2 or ANSI/TIA-568-C.2.
- T568B is the preferred wiring scheme for easier troubleshooting but T568A may be used if required by the customer.
- Cable Jacket should be selected to meet local codes and voltage ratings for application.

6.3 BACnet Router RS485 Detail

In a CC200 BACnet network, one CC200 per network or "comm. loop" will be a BACnet router device. All other CC200s within the same network will be non-router BACnet IP devices. All BACnet IP CC200 devices will connect to their respective router with a field-installed CAT5e cable.

The router device will be the only CC200 with RS485 twisted pair wiring. For E2E a maximum of 32 CC200 BACnet devices per "comm loop" per supervisor serial port is allowed. A maximum total of 64 CC200 BACnet devices across all E2E serial ports is allowed. The router CC200 and all connected BACnet IP CC200s count towards the maximum. Copeland specs General Cable 92454A (**Copeland P/N 135-0600**) shielded twisted pair cables for use as BACnet MS/TP RS-485 wiring.

Configuring a CC200 as the BACnet router is covered in [Section 6.4, BACnet Router RS485 Specifications](#) of this manual. The diagram below shows the RS485 connection detail between the CC200 router device RS485 port and the E2E RS485 port. All other devices in a "comm loop" will connect to the router with field-installed CAT5e cable and CC200 onboard ETH1 and ETH2 ports.

Note: When using a Supervisory Controller with RS485 COM A and COM B Ports (E2E or E3) ONLY the COM A port can be used for BACnet MSTP; the COM B port connector MUST remain unused for BACnet MSTP Networks. This is due to BACnet MSTP being a token passing network and all devices must be on the same physical network cable segment for successful token creation and passing.

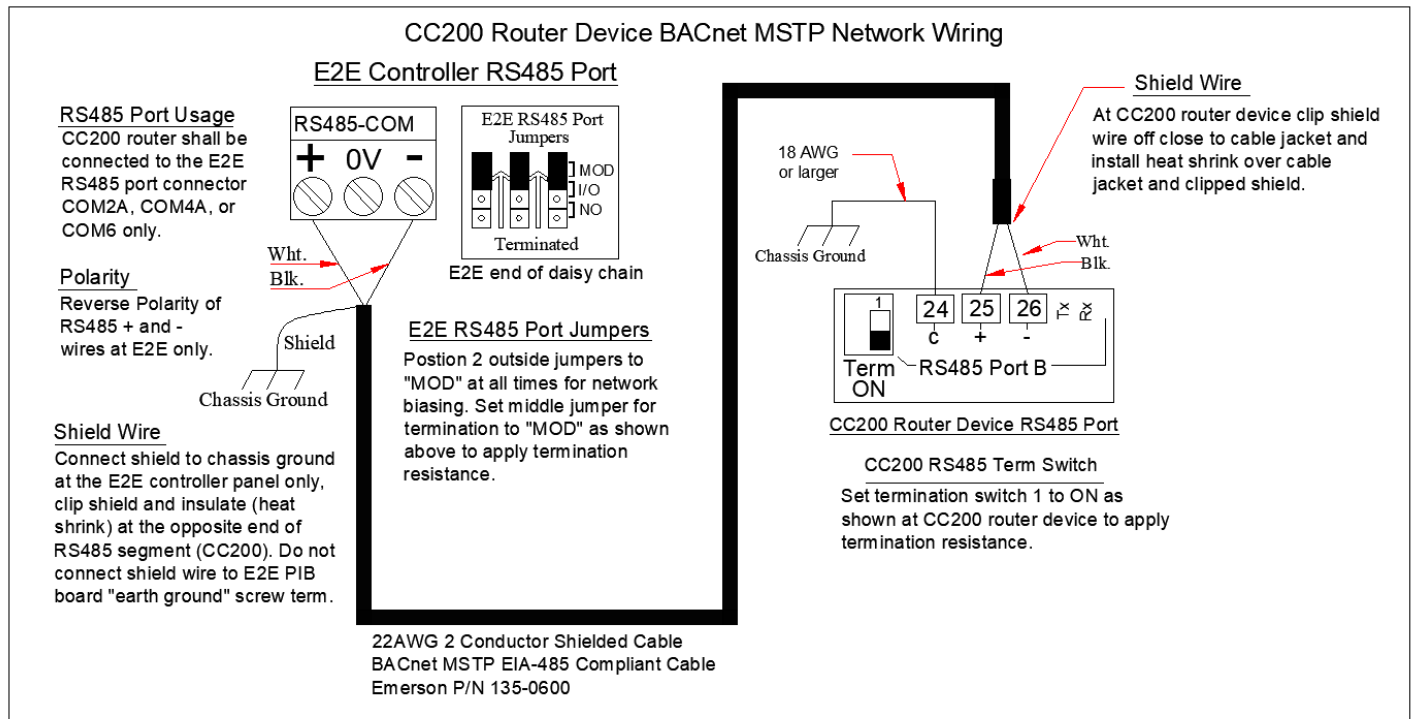

BACnet Router Device MS/TP Wiring for E2

CC200 Router Device BACnet MSTP Network Wiring

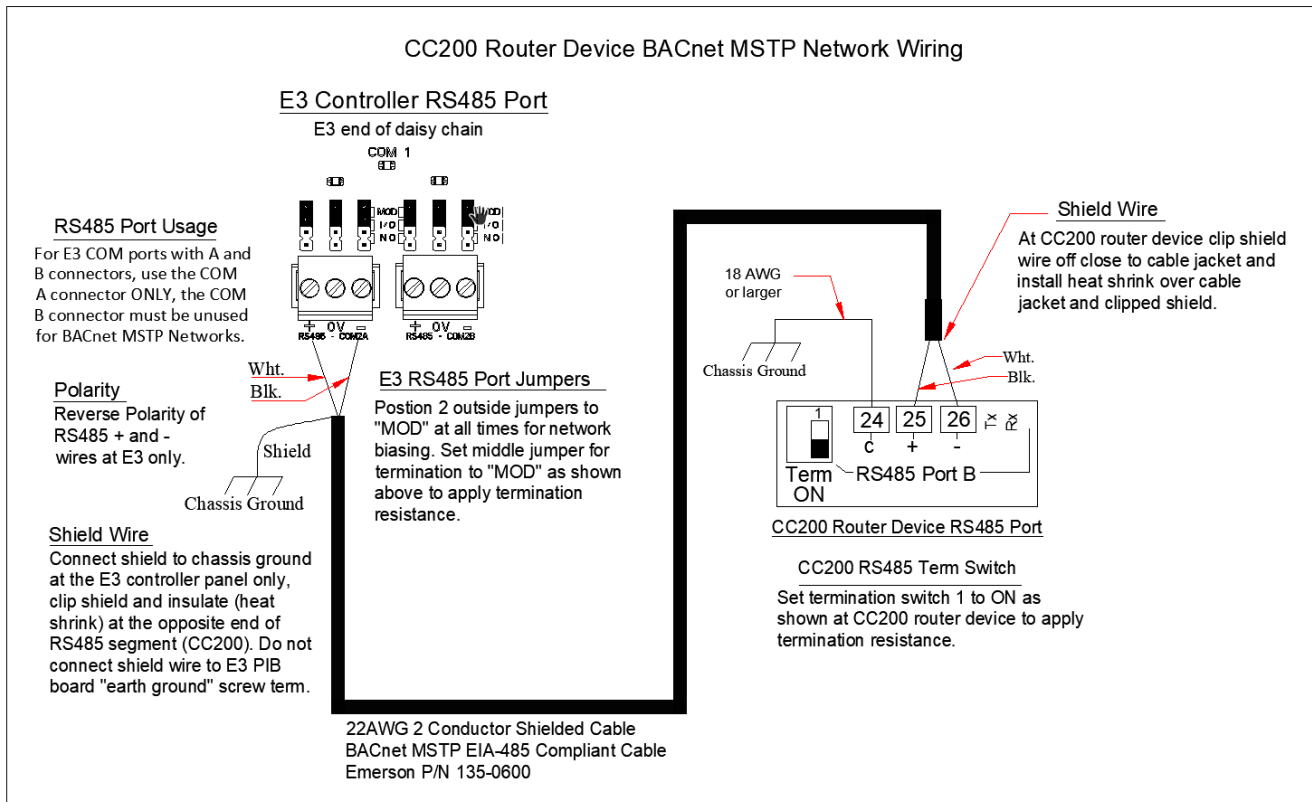

BACnet Router Device MS/TP Wiring for E3

6.4 BACnet Router RS485 Specifications

For BACnet communication with a Supervisory Controller, the CC200 uses a BACnet router topology. The CC200 BACnet network always contains one router device and a number of other non-router/BACnet IP devices. The router is the only CC200 that has RS485 shielded twisted pair cable terminated to it.

Installers must use the shielded twisted cable listed below so that ASHRAE and EIA-485 compliance is maintained for all BACnet installations.

- **RS485 Cable Type Requirement:** Copeland P/N 135-0600 or Echelon Level 4.
- **RS485 Cable Specs:**
 - Shielded Twisted Pair
 - 18-24 AWG
 - **Capacitance Between Signal Wires:** 30pf/ft (100pf/m) or Less.
 - **Capacitance Between Signal and Shield:** 60pf/ft (200pf/m) or Less.
 - **Nominal Impedance:** 100 to 130 Ohms.
- **RS485 Network Guidelines:**
 - **Maximum Cable Distance:** 1200ft at 57600 Baud Rate.
 - **Termination at E2E:** If E2E is a network end point then terminate at E2E using serial port jumpers - To terminate, set all three (3) Jumpers to the **MOD** position. Terminate the other end point of the network using CC200 RS485 Term Switch or 150 Ohms.
- **Shields and Grounding:**

Do not connect the shields to the device serial port plugs on E2E or BACnet controllers.

 - RS485 cable shield should be securely landed to earth ground at one of the network end points only (preferably at E2E panel if E2E is an endpoint); clip shield wire and insulate on opposite network end point.
 - CC200 BACnet MS/TP RS485 port "C" terminal has an internal 100 Ohm connection to RS485 reference ground and the "C" terminal should be connected directly to earth ground/chassis.

6.5 Configuring BACnet Settings on the CC200 Case Display

The network address and device ID makes a board unique from other boards on the network of the same type. This allows the Supervisory Controller to find and communicate with it. The Case Controller BACnet settings can be set using the CC200 Case Display.

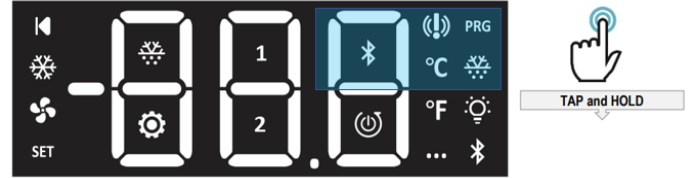

CC200 Case Display Unlock

Identify which CC200 controller will be the router and configure that device according to the instructions in the [Router Devices Section](#). Usually the device that is closest in physical distance from the E2E can be configured as the router in order to keep the RS485 cable distance short. However, other network cabling factors may dictate that another device is chosen to be the router.

Router Devices

1. Identify the CC200 that will be the MS/TP to IP router. On the router device the router functionality as well as MS/TP settings must be configured. All other devices will leave the router disabled and MS/TP settings are not required.
2. On the router device, unlock the display. Push and hold the upper right corner for 5 seconds and the display will beep and **PRG** and **SET** will become visible.
3. With the display unlocked tap and hold **PRG** again for 3 seconds to reach the **BAC** group for BACnet settings. **BAC** will be displayed.
4. From **BAC**, tap **PRG** again to enter the parameter menu, **ADr** will be displayed. Tap **PRG** to enter edit mode on **ADr**. Swipe up or down on the digits to choose a unique MS/TP MAC for this controller, once selected push and hold **PRG** for 3 seconds to save the edit. Once saved the value will flash, display will beep and return to the **ADr** parameter label.
5. From **ADr** swipe horizontally right to left to reach **baU** for MS/TP baud rate, tap **PRG** to enter edit mode. Swipe up/down to select the baud rate used for communication with the Supervisor Controller. Once selected, hold **PRG** for 3 seconds to save the value, the value will flash, display will beep and return to the **baU** parameter label.
6. **Note: Only CC200 1.03F01 and newer have the IP1 parameter.** From **baU** horizontal swipe right to left to reach **"iP1"** for IP Address octet 1. This sets the value of octet 1 of the IP address. For BACnet installations using the router topology, leave at the default of 10. Proceed to **rId** parameter.
7. From **iP1** horizontal swipe left to right to reach **rId** for rack ID. This sets the refrigeration rack system ID which is used for calculating BACnet device ID. Tap **PRG** to enter edit mode. Swipe up/down to select the rack ID, which is A for rack A, B for rack B. Once selected push and hold **PRG** for 3 seconds to save the edit. Once saved the value will flash, display will beep and return to the **"rId"** parameter label.
8. From **"rId"** horizontal swipe right to left to reach **Lid** for circuit lineup ID. This sets the refrigeration circuit ID which is used for calculating BACnet device ID. Tap **PRG** to enter edit mode. Swipe up/down to select the circuit number. Once selected push and hold **PRG** for 3 seconds to save the edit. Once saved the value will flash, the display will beep and return to the **Lid** parameter label.
9. From **Lid** horizontal swipe right to left to reach **Cid** for case id. This sets the case letter ID which is used for calculating BACnet device ID. Tap **PRG** to enter edit mode. Swipe up/down to select the case letter. Once selected push and hold **PRG** for 3 seconds to save the edit. Once saved the value will flash, display will beep and return to the **Cid** parameter label.
10. From **Cid** horizontal swipe right to left to reach **CiL** for cases in lineup. This sets number of cases in the lineup including this device. For single case systems set = 1, for lineups set the number of cases in the lineup including this device. Tap **PRG** to enter edit mode. Swipe up/down to select the value. Once selected, push and hold **PRG** for 3 seconds to save the edit. Once saved the value will flash, display will beep and return to the **CiL** parameter label.
11. From **CiL** horizontal swipe right to left to reach **"rtr"**. This enables/disables the route, tap **PRG** to enter edit mode. Swipe up/down to select yes/no. Select **Yes** only on the CC200 that will be the router. Once selected, push and hold **PRG** for 3 seconds to save the edit. Once saved the value will flash, display will beep and return to the **"rtr"** parameter label.
12. Lastly, from **"rtr"** swipe from right to left to reach **Sav**. Tap **PRG** to enter edit mode. Swipe up/down to select Yes or No. Select **Yes** to save and initialize all BACnet changes. Once selected push and hold **PRG** for 3 seconds to save the edit. Once saved the value will flash, display will beep and return to the **Sav**. After **Sav** is set to **Yes** the CC200 will automatically reboot to initialize BACnet settings.

Non-Router Devices

Only the rack id (rid), circuit lineup id (Lid) and case id (Cid) must be set on the non-router devices.

1. With the display unlocked tap and hold **PRG** again for 3 seconds to reach the **BAC** group for BACnet settings. **BAC** will be displayed.
2. From **BAC**, tap **PRG** again to enter the parameter menu, **ADr** will be displayed. Horizontally swipe from right to left to reach rid.
3. Tap **PRG** to enter edit mode. Swipe up/down to select the rack ID, which is A for rack A, B for rack B. Once selected, push and hold **PRG** for 3 seconds to save the edit. Once saved the value will flash, display will beep and return to the **"rid"** parameter label.
4. From **"rid"** horizontal swipe right to left to reach Lid for circuit lineup ID. This sets the refrigeration circuit ID, which is used for calculating BACnet device ID. Tap **PRG** to enter edit mode. Swipe up/down to select the circuit number. Once selected push and hold **PRG** for 3 seconds to save the edit. Once saved the value will flash, display will beep and return to the **Lid** parameter label.
5. From **Lid** horizontal swipe right to left to reach **Cid** for case id. This sets the case letter ID, which is used for calculating BACnet device ID. Tap **PRG** to enter edit mode. Swipe up/down to select the case letter. Once selected push and hold **PRG** for 3 seconds to save the edit. Once saved the value will flash, display will beep and return to the **Cid** parameter label.
6. From **Cid** horizontal swipe right to left to reach **CiL** for cases in lineup. This sets number of cases in the lineup including this device. For single case systems set = 1, for lineups set the number of cases in the lineup including this device. Tap **PRG** to enter edit mode. Swipe up/down to select the value. Once selected push and hold **PRG** for 3 seconds to save the edit. Once saved the value will flash, display will beep and return to the **CiL** parameter label.
7. From **CiL** swipe horizontally right to left to reach **"rtr"**. Ensure **"rtr"** is set to **No** for all non-router devices.
8. Lastly, from **"rtr"** swipe from right to left to reach **Sav**. Tap **PRG** to enter edit mode. Swipe up/down to select **Yes** or **No**. Select **Yes** to save and initialize all BACnet changes. Once selected push and hold **PRG** for 3 seconds to save the edit. Once saved the value will flash, display will beep and return to the **Sav**. After **Sav** is set to **Yes** the CC200 will automatically reboot to initialize BACnet settings.

BACnet IP Devices for Connection to E3

IP address octet 1 (iP1), rack id (rid), circuit lineup id (Lid) and case id (Cid) must be set on devices for the E3 BACnet IP network. MS/TP related parameters can be skipped.

Most BACnet IP networks with E3 Ethernet port 1 should set the value of all the CC200 IP address octet 1 to 192 so the CC200s are in the same subnet as the E3 ETH 1 port and E3 PIB board.

1. With the display unlocked tap and hold **PRG** again for 3 seconds to reach the **BAC** group for BACnet settings. **BAC** will be displayed.
2. From **BAC**, tap **PRG** again to enter the parameter menu, **ADr** will be displayed. Horizontally swipe from right to left to reach **iP1** parameter.
3. Tap **PRG** to enter edit mode on **iP1**. Swipe up/down to set **iP1** to **192**, note swiping up/down on all 3 digit places individually works to change each digit to **192**. Once **192** is selected, push and hold **PRG** for 3 seconds to save the edit. Once saved the value will flash, display will beep and return to the iP1 parameter label.
4. From **iP1** horizontal swipe right to left to reach rid for Rack ID. Tap **PRG** to enter edit mode. Swipe up/down to select the rack ID, which is A for rack A, B for rack B, etc. Rack ID is used in automatically setting the BACnet device ID and octet 2 of the IP address. Once selected, push and hold **PRG** for 3 seconds to save the edit. Once saved the value will flash, display will beep and return to the **"rid"** parameter label.
5. From **"rid"** horizontal swipe right to left to reach **Lid** for circuit lineup ID. This sets the refrigeration circuit ID, which is used for calculating BACnet device ID and octet 3 of the IP address. Tap **PRG** to enter edit mode. Swipe up/down to select the circuit number. Once selected push and hold **PRG** for 3 seconds to save the edit. Once saved the value will flash, display will beep and return to the **Lid** parameter label.
6. From **Lid** horizontal swipe right to left to reach **Cid** for case id. This sets the case letter ID, which is used for calculating BACnet device ID and octet 4 of the IP address. Tap **PRG** to enter edit mode. Swipe up/down to select the case letter. Once selected push and hold **PRG** for 3 seconds to save the edit. Once saved the value will flash, display will beep and return to the **Cid** parameter label.
7. From **Cid** horizontal swipe right to left to reach **CiL** for cases in lineup. This sets number of cases in the lineup including this device. For single case systems set = 1, for lineups set the number of cases in the lineup including this device. Tap **PRG** to enter edit mode. Swipe up/down to select the value. Once selected push and hold **PRG** for 3 seconds to save the edit. Once saved the value will flash, display will beep and return to the **CiL** parameter label.
8. From **CiL** swipe horizontally right to left to reach **"rtr"**. Ensure **"rtr"** is set to **No** for all non-router devices.
9. Lastly, from **"rtr"** swipe from right to left to reach **Sav**. Tap **PRG** to enter edit mode. Swipe up/down to select **Yes** or **No**. Select **Yes** to save and initialize all BACnet changes. Once selected push and hold **PRG** for 3 seconds to save the edit. Once saved the value will flash, display will beep and return to the Sav. After **Sav** is set to **Yes** the CC200 will automatically reboot to initialize BACnet settings.

6.6 Modbus Network

CC200 version 1.01F01 and later supports Modbus RTU communication to the E3, E2E, Site Supervisor or other Modbus capable controllers. CC200 can communicate in an RS485 daisy chain topology. For a Modbus RTU installation, CAT5e cable is still required within refrigeration lineups/defrost groups to enable CC200 peer to peer communication as described in the Case Lineup Management section of this manual. RS485 shielded twisted pair is daisy chained to all CC200 controllers and back to the supervisor serial port, CAT5e is connected within lineups only. Single standalone cases and walk in applications, which do not require coordination of defrost, also do not need CAT5e cable runs.

Refer to [Modbus and Case Lineup for E2](#) diagram for network details.

Ring and star topologies must be avoided and are not supported under any circumstance. Integration files for Copeland E3, E2E and Site Supervisor are available for use. RS485 Port B on the CC200 will be used for Modbus RS485 communications, see wiring detail below for detailed connection information. Configuring the CC200 for Modbus communication is covered in [Section 6.7, Configuring Modbus Settings on the CC200 Case Display](#) of this manual.

MODBUS Cable Requirements

Copeland specifies the following wire for use in Modbus RS485 CC200 daisy chain topologies:

For 9600 or 19200 baud rate, cable must be 22 or 24 AWG, 2 conductor, shielded and EIA 485 compliant:

- Belden 8761 **Copeland P/N 035-0002**,
- Belden 8641 **Copeland P/N 135-8641**,
- General Cable **Copeland P/N 135-0600**, or
- Echelon Level 4 cable may be used.

Maximum cable distance of 4000ft.

For Modbus installations using 38400 baud rate or 57600 baud rate, the General Cable P/N 135-0600 or Echelon Level 4 cable must be used with maximum cable distance of 2000ft for 38400 baud, or 1200ft for 57600 baud.

CAT5e Cable Requirements

The CC200 peer to peer communication CAT5e cable, crimping and install guidelines are the same as those documented in [Section 6, The BACnet Network](#) of this manual. Refer to this section for cable, crimping and install guidelines.

CC200 Modbus and Case Lineup CAT5e

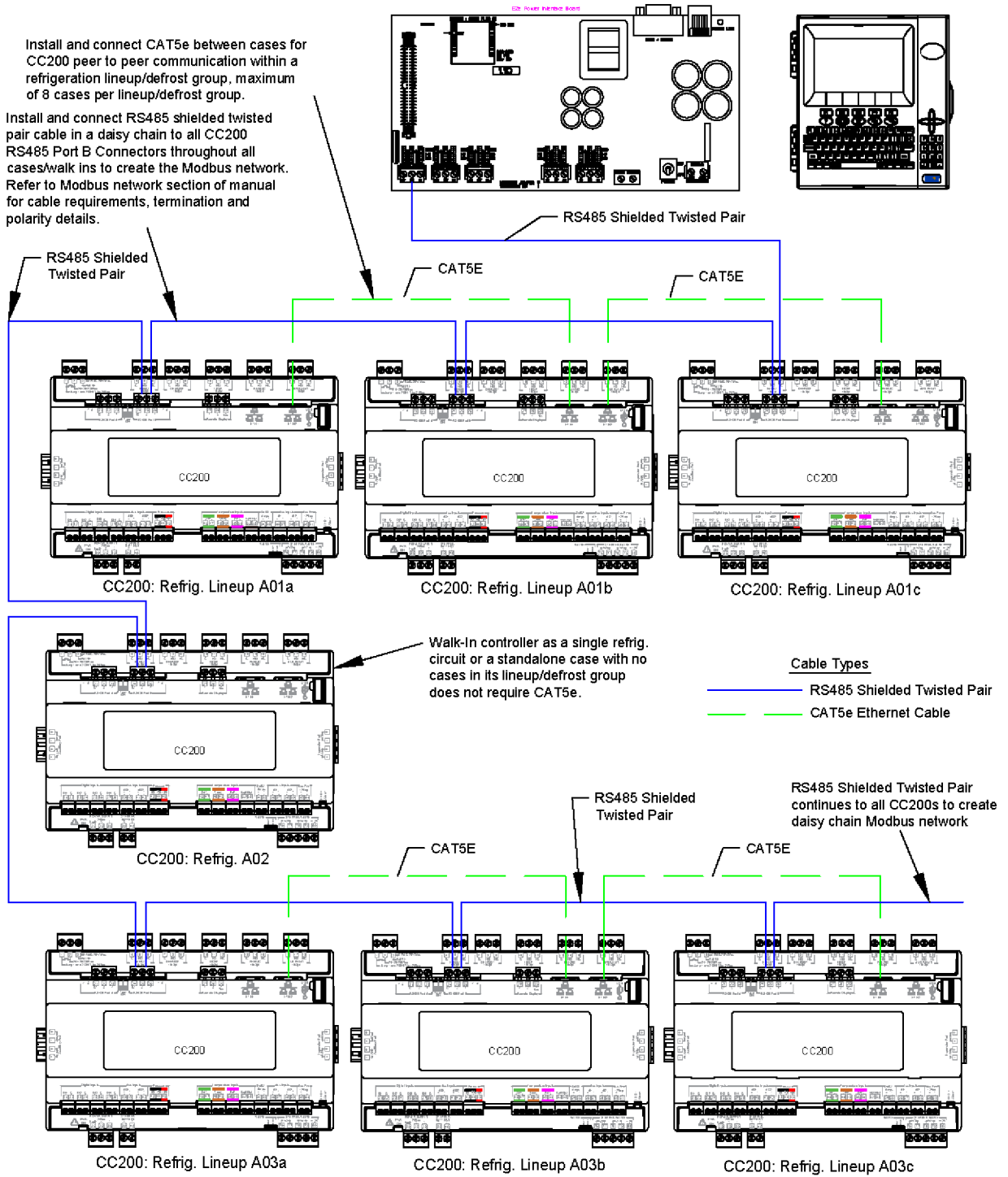

Modbus and Case Lineup for E2

CC200 Modbus and Case Lineup CAT5e

Install and connect CAT5e between cases for CC200 peer to peer communication within a refrigeration lineup/defrost group, maximum of 8 cases per lineup/defrost group.

Install and connect RS485 shielded twisted pair cable in a daisy chain to CC200 RS485 Port B Connectors on the planned network segment. Refer to Modbus network section of manual for cable requirements, termination and polarity details.

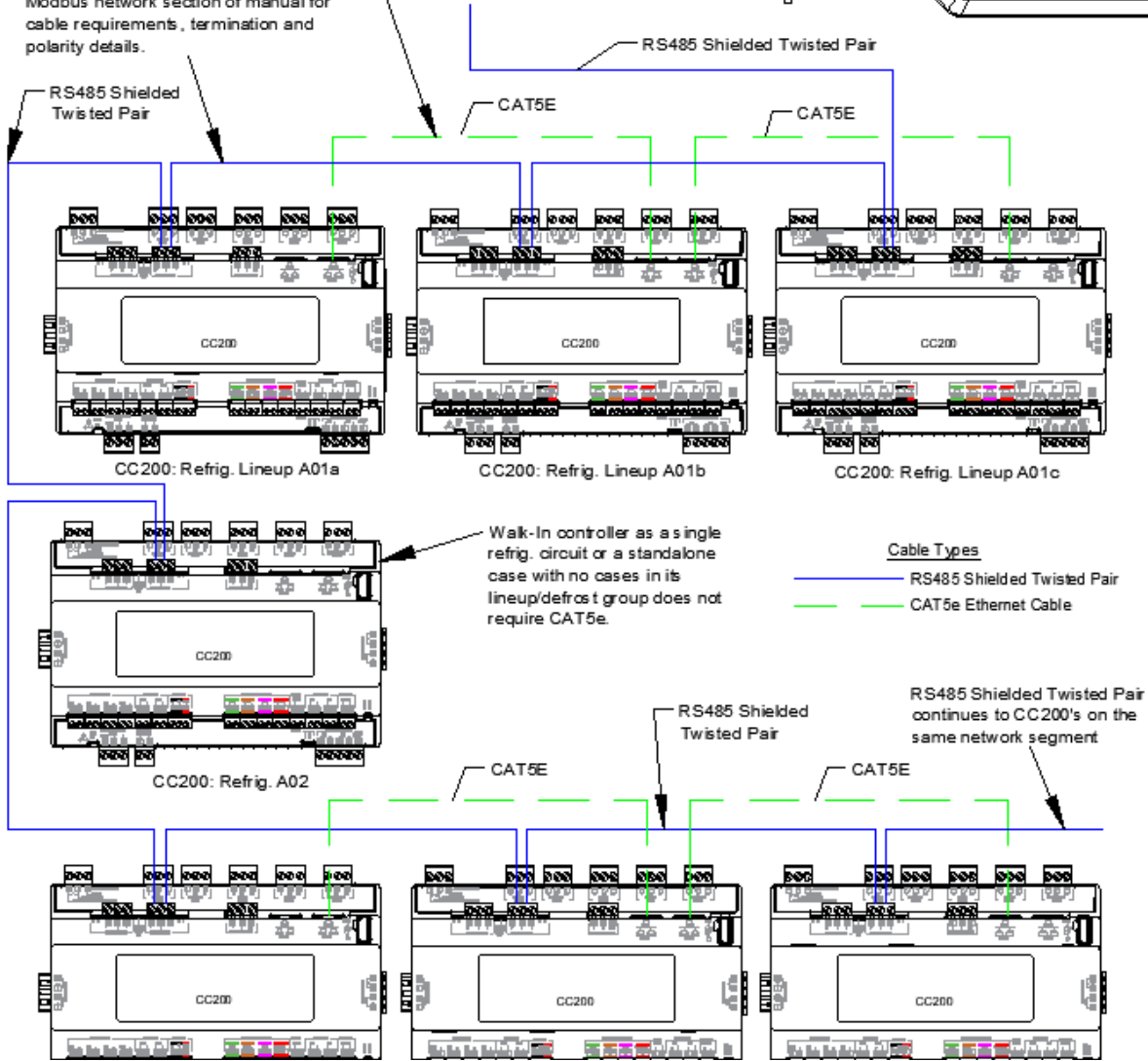
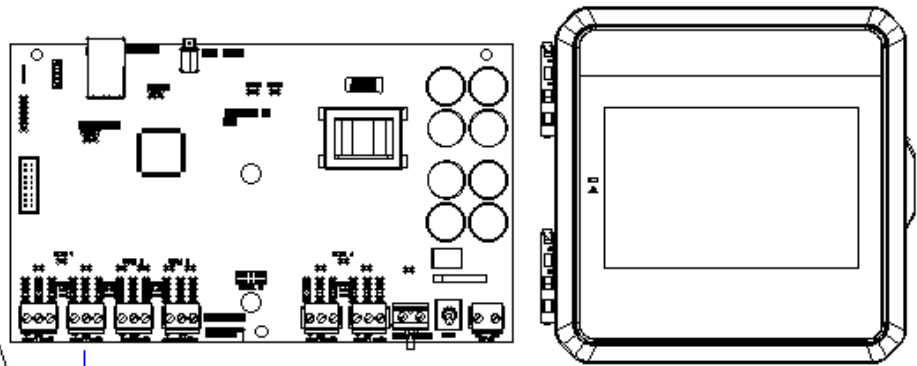

Modbus and Case Lineup for E3

RS485 Modbus Network Wiring

E2E Controller RS485 Port

E2E RS485 Port Usage

CC200 Modbus can be connected to any E2E RS485 port connector-COM2A, COM2B, COM4A, COM4B and/or COM6.

Polarity

Reverse Polarity of RS485 + and - wires at E2E only

Shield Wire

Connect shield to chassis ground at the E2E controller panel only, clip shield and insulate (heat shrink) at the opposite end of RS485 segment (CC200). Do not connect shield wire to E2E PIB board "earth ground" screw term.

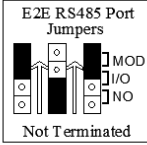
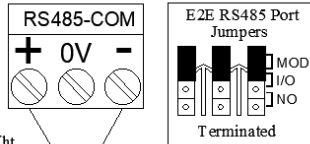

E2E RS485 Port Jumpers

Position 2 outside jumpers to "MOD" at all times for network biasing. If E2E is a daisy chain endpoint, set middle jumper for termination to "MOD" as shown above to apply termination resistance. If E2E is in the middle of a daisy chain, set middle jumper to NO.

22 or 24 AWG 2 Conductor Shielded Cable (EIA-485 Compliant Cable, Belden 8761, Belden 8641, or Echelon Level 4 may be used)

CC200 RS485 Port B

Shield Wire-Middle of Daisy Chain

All CC200 devices on the daisy chain keep shield wire continuous by twisting and soldering shields. Use heat shrink to insulate shield wire.

Shield Wire-End of Daisy Chain

At CC200 device at end of daisy chain, clip shield wire off close to jacket. Insulate with heat shrink.

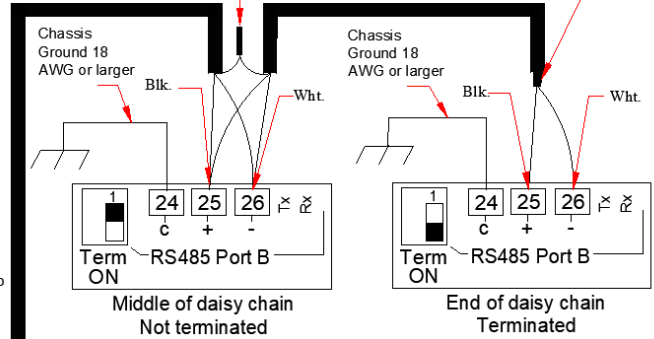

CC200 Termination Switch

For the CC200 which is a daisy chain endpoint, set term switch 1 as shown above in 'End of daisy chain-terminated' detail. For all CC200's which are in the middle of a daisy chain set term switch 1 as shown above in 'Middle of daisy chain-Not terminated' detail.

RS485 Modbus Network Wiring for E2

RS485 Modbus Network Wiring

E3 Controller RS485 Port

E3 RS485 Port Usage

CC200 Modbus can be connected to any available open E3 RS485 port connector.

Polarity

Reverse Polarity of RS485 + and - wires at E3 only

Shield Wire

Connect shield to chassis ground at the E3 controller panel only, clip shield and insulate (heat shrink) at the opposite end of RS485 segment (CC200). Do not connect shield wire to E3 PIB board "earth ground" screw term.

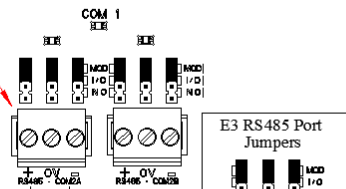

E3 end of daisy chain

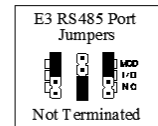

E3 middle of daisy chain

E3 RS485 Port Jumpers

Position 2 outside jumpers to "MOD" at all times for network biasing. If E3 is a daisy chain endpoint, set middle jumper for termination to "MOD" as shown above to apply termination resistance. If E3 is in the middle of a daisy chain, set middle jumper to NO.

22 or 24 AWG 2 Conductor Shielded Cable (EIA-485 Compliant Cable, Belden 8761, Belden 8641, or Echelon Level 4 may be used)

CC200 RS485 Port B

Shield Wire-Middle of Daisy Chain

All CC200 devices on the daisy chain keep shield wire continuous by twisting and soldering shields. Use heat shrink to insulate shield wire.

Shield Wire-End of Daisy Chain

At CC200 device at end of daisy chain, clip shield wire off close to jacket. Insulate with heat shrink.

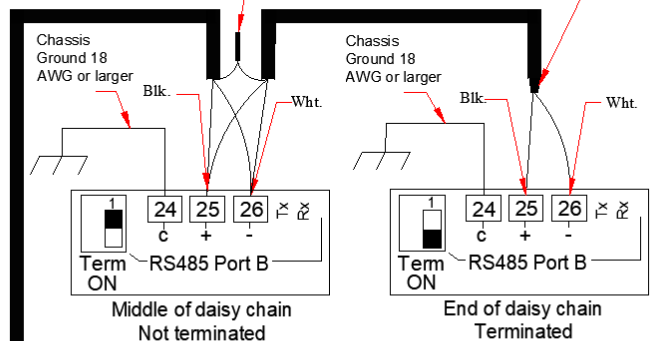

CC200 Termination Switch

For the CC200 which is a daisy chain endpoint, set term switch 1 as shown above in 'End of daisy chain-terminated' detail. For all CC200's which are in the middle of a daisy chain set term switch 1 as shown above in 'Middle of daisy chain-Not terminated' detail.

RS485 Modbus Network Wiring for E3

6.7 Configuring Modbus Settings on the CC200 Case Display

The network address makes a board unique from other boards on the network of the same type. This allows the Supervisory controller to find and communicate with it. Each CC200 server device on the RS485 daisy chain must have a unique address. All server devices on the RS485 daisy chain must use the same baud rate, stop bits, data bits and parity. Use the instructions here to set the Modbus settings from the display.

Unlock the display. Push and hold the upper right corner for 5 seconds. The display will beep and **PRG** and **SET** will become visible.

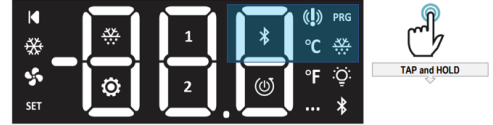

1. Unlock the display. Push and hold the upper right corner for five (5) seconds. The display will beep and **PRG** and **SET** will become visible.
2. With the display unlocked tap and hold **PRG** again for three (3) seconds, the parameter group **PCL** will be visible.
3. Tap **PRG** to enter the **PCL** group, the parameter **CON** will be shown. This is where the communication protocol is selected.
4. Tap **PRG** on **CON** to enter **Edit** mode.
5. Swipe up/down between options **nrt** and **biP**. Choose **nrt** for Modbus RS485, push and hold **SET** for three (3) seconds to save the edit. Once saved, the value will flash and the display will return to the **CON** parameter label.
6. Tap the top right arrow key one time to return to **PCL**, swipe from right to left two times to reach the NOD parameter group. Tap **PRG** to enter **NOD**, and **ADr** will be shown for the Modbus address.
7. Tap **PRG** to enter **Edit** mode on **ADr**. Swipe up or down on the digits to choose a unique Modbus address. Push and hold **PRG** for three (3) seconds to save the edit. Once saved, the value will flash, the display will beep and return to the **ADr** parameter label.
8. From **ADr**, swipe horizontally right to left to reach **baU** for baud rate, tap **PRG** to enter **Edit** mode. Swipe up/down to select the baud rate used for communication with the Supervisor controller. Once selected, hold **PRG** for three (3) seconds to save the value; the value will flash, the display will beep and return to the **baU** parameter label.
9. From **baU**, horizontally swipe right to left to reach "**rid**" for rack ID. This sets the refrigeration rack system ID that is used for setting the IP address for peer-to-peer communication within a circuit lineup. Tap **PRG** to enter edit mode. Swipe up/down to select the rack ID, which is A for rack A, B for rack B. Once selected, push and hold **PRG** for three (3) seconds to save the edit. Once saved, the value will flash, the display will beep and return to the "**rid**" parameter label.

Note: iP1 parameter was introduced in CC200 1.03F01 for setting IP address octet 1 for BACnet IP networks. iP1 is not required to be changed for Modbus networks, leave at the default of 10.

10. From "**rid**" horizontally swipe right to left to reach **Lid** for circuit lineup ID. This sets the refrigeration rack system ID that is used for setting the IP address for peer-to-peer communication within a circuit lineup. Tap **PRG** to enter edit mode. Swipe up/down to select the circuit number. Once selected push and hold **PRG** for three (3) seconds to save the edit. Once saved, the value will flash, the display will beep and return to the **Lid** parameter label.
11. From **Lid**, horizontally swipe right to left to reach **Cid** for Case ID. This sets the refrigeration rack system ID, which is used for setting the IP address for peer-to-peer communication within a circuit lineup. Tap **PRG** to enter Edit mode. Swipe up/down to select the case letter. Once selected, push and hold **PRG** for three (3) seconds to save the edit. Once saved, the value will flash, the display will beep and return to the **Cid** parameter label.
12. From **Cid**, horizontally swipe right to left to reach **CiL** for cases in lineup. This sets number of cases in the lineup including this device. For single case systems set = 1, for lineups, set the number of cases in the lineup including this device. Tap **PRG** to enter edit mode. Swipe up/down to select the value. Once selected, push and hold **PRG** for three (3) seconds to save the edit. Once saved, the value will flash, the display will beep and return to the **CiL** parameter label.
13. From **CiL**, horizontally swipe right to left to reach **dAt** to set the Modbus message number of data bits. The default value of 8 should be left for communication to E3, Site Supervisor, and E2. Values may be adjusted and saved for communication to other Modbus master systems. Tap the back arrow key to return to **dAt**.
14. From **dAt**, horizontally swipe right to left to reach **PAr** for Modbus message parity. The default value of nOn should be left for communication to E3, Site Supervisor, and E2. Values may be adjusted and saved for communication to other Modbus master systems. Tap the back arrow key to return to **PAr**.
15. From **PAr**, horizontally swipe right to left to reach **StP** to edit the Modbus message number of stop bits. The default value of 0 should be left for communication to E3, Site Supervisor and E2. Values may be adjusted and saved for communication to other Modbus master systems. Tap the back arrow key to return to **StP**.
16. From **StP**, horizontally swipe from right to left to reach **SAv** to save Modbus settings. Tap **PRG** to enter edit mode. Swipe up/down to select yes. Once yes is selected, push and hold **PRG** for three (3) seconds to save the edit. Once saved, the value will flash, the display will beep and return to Sav. After **SAv** is set to yes the CC200 will automatically reboot to initialize the Modbus settings for proper communication.

7. E2 Setup

The Case Controller is capable of communicating with the E2E Controller version 4.10F02 or above. Using the Case Controller with E2E offers benefits over using the Case Controller as a stand-alone device.

- Remotely upgrade firmware of the CC200
- Reporting of case controller-related alarms
- The ability to log case controller data in an E2E logging group
- The ability to shut down refrigeration for walk-in boxes in event of a refrigerant leak event (available if a Copeland leak detection panel is used)
- Remote access to case controller status and programming from the E2E front panel
- The ability to remotely access the case controllers using UltraSite32 or Connect+

Communication between E2E and the Case Controller takes place over the RS485 BACnet MS/TP network. Follow the instructions in [Section 6, The BACnet Network](#) to connect a Case Controller to the E2E network and comm plug connector. Then follow the instructions in this chapter to set up the Case Controller in the E2E. An E2E has up to three COM ports that can be assigned for BACnet MS/TP communication: COM2, COM4 and COM6 are the available RS485 ports on the E2E power interface board. The Case Controller daisy chain must only be connected to E2E serial port connectors **2a**, **6**, or **4a**.

Connecting a daisy chain of BACnet Case Controllers to the “a” and “b” side of the serial port simultaneously is not supported.

7.1 Set Up Network Ports and BACnet Settings

Before setting up a Case Controller in the E2E, the port that has the BACnet MS/TP cable connected to it must be set up as a BACnet MS/TP port.

1. Log into the E2E with level 4 access or higher.
2. Press **Alt** + **M** on the keyboard to access the serial tab of the general controller info setup screens.
3. This screen will have a connection field for all available COM ports on the E2E. Highlight the COM port connection you will be using for BACnet MS/TP and press **F4**:LOOK UP and select **BACnet MS/TP** from the list of network types.
4. Three fields will become visible underneath the COM4 Connection that pertain to the way the device communicates:

- **COM4 DevId** - This is the E2E BACnet Device ID; set this to a unique number from all other BACnet nodes on the network in the range of **0-4194303**. Usually setting the E2E Device ID the same number as the MSTP MAC is sufficient.
- **COM4 MSTP MAC** - This is the E2E BACnet MSTP MAC address; set this to a unique number for E2E in the range of **1-127**. Each BACnet device on the network must have its own unique MSTP MAC in order to communicate.
- **COM4 Baud** - Default setting is **9600**; this must be changed to **57600** on the E2E and the CC200 configured as the BACnet router (all devices connected to the same COM port should be set to the same baud rate).

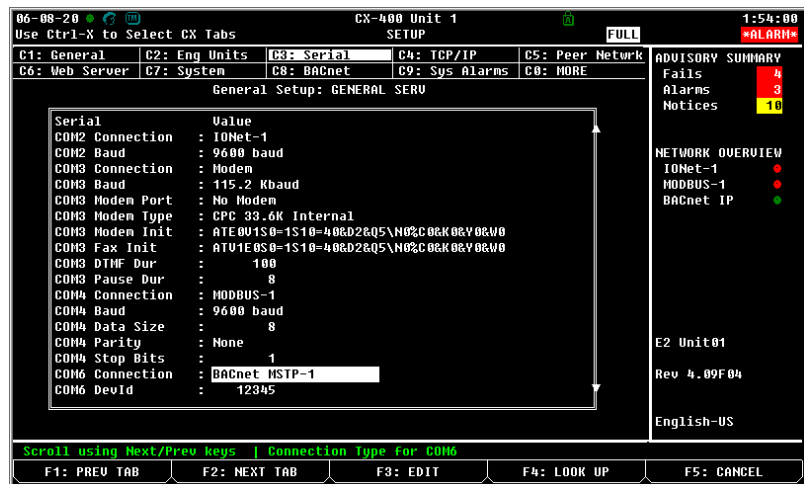



Serial Setup in General Configuration

7.2 Configure E2E BACnet Settings

After setting up the BACnet MS/TP port, the BACnet network settings must be configured.

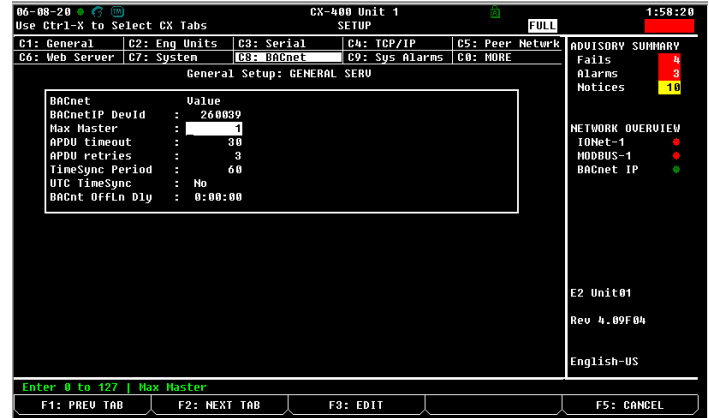
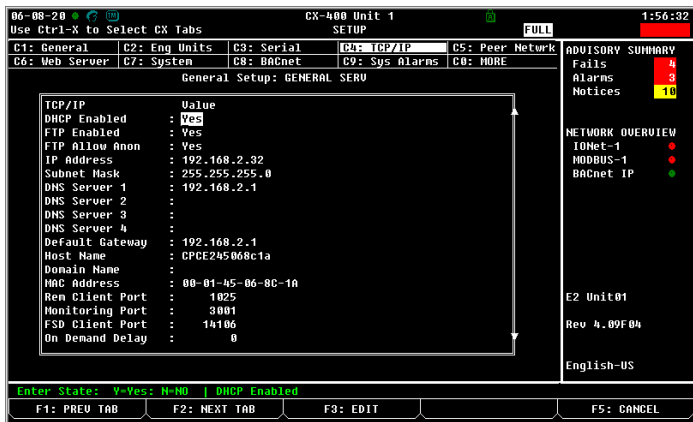

- From the Home screen on E2E, press **Alt** + **T** on the keypad to navigate to this screen:
- Press **Ctrl** + **8** to reach the BACnet tab:



- Three settings must be configured here:
 - Max Master** - The default setting is **127**, edit and change the value to be equal to the highest BACnet mac address that E2E will communicate with any of its three (3) comm ports. A maximum of 32 Case Controllers is allowed per serial port on E2E, setting Max Master to 40 is sufficient to be able to discover all Case Controllers. If there are other BACnet MS/TP devices on the daisy chain besides E2E and Case Controllers, determine the highest MS/TP MAC address of any device connected to any of the E2E comm ports. Set the E2E Max Master equal to the highest MS/TP MAC address determined.
 - APDU Timeout** - This is the amount of time in seconds between retransmissions of an APDU requiring acknowledgment for which no acknowledgment has been received. Enter a value of **30** in this field.
 - APDU Retries** - This is the maximum amount of times that an APDU shall be retransmitted. Enter a value of **3** in this field.
- After timeout, retries, and Max Master have been set, press the  button to save and exit.

7.3 Add and Connect Case Controllers

To enable communications between the E2E and the Case Controllers, the devices must be added to E2E and addressed.

- Log into the E2E with level 4 access or higher.
- Press **Menu**, **7**, **7**, **2** to access **Connected I/O Boards and Controllers**.
- In the Connected I/O screen under the **Third Party** tab, enter the number of Case Controller devices in the Quantity field.
- Press the  button.
- Press the  button to return to the home screen.
- Press **Alt** + **N** on the keyboard to access the Network Summary screen.
- The number of Case Controller units added in Step 3 should now be visible in the Network Summary screen.

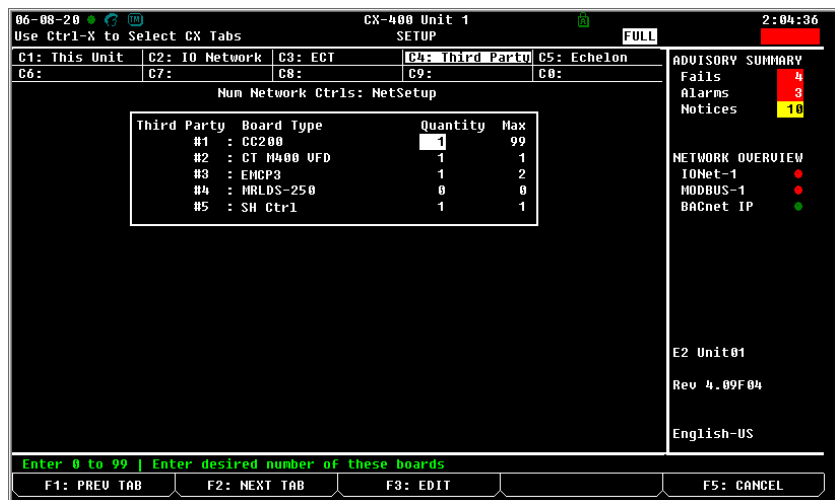

7.4 Commissioning the Device in E2E

- From the network summary screen highlight the first device and press **F4** to commission the device.

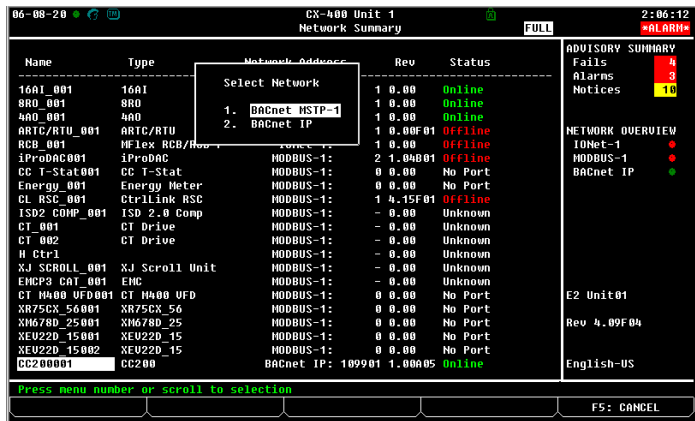

- Select the BACnet MS/TP network, the E2E will then scan for available devices:

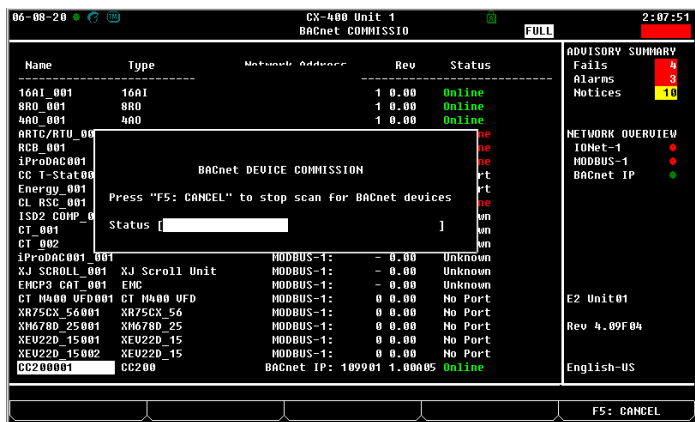

- The E2E will display a list of the devices discovered during the scan:

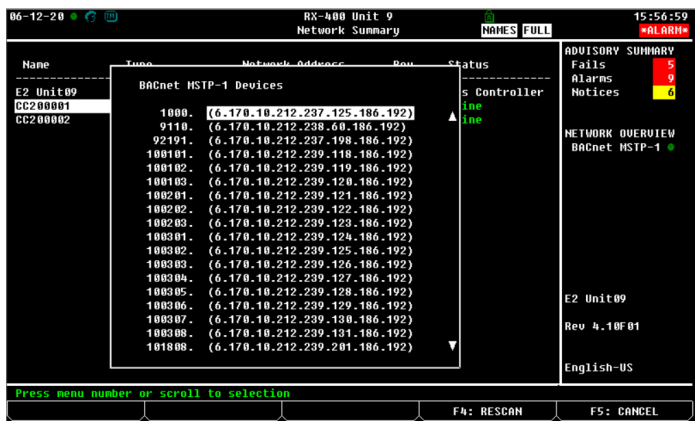

- The number in parenthesis is the BACnet MAC address and the six-digit number adjacent to it is the BACnet Device ID. Select the device you want to commission and press **Enter** on the E2E keypad.

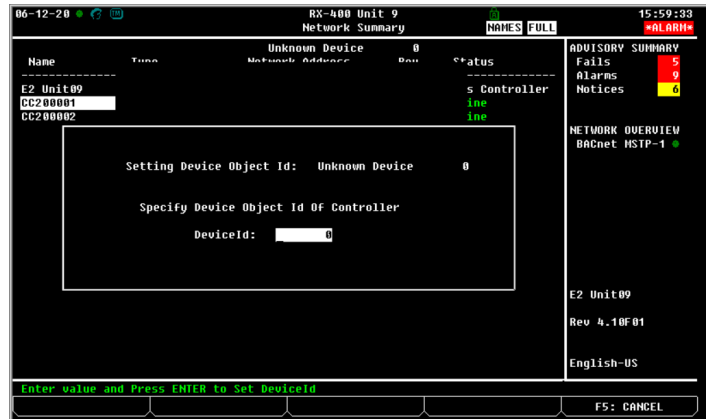

- Press **Enter** again on E2E keypad and then E2E will display BACnet Device ID is set.



- Then press the **Save** button to save and exit back to the Network Summary screen:

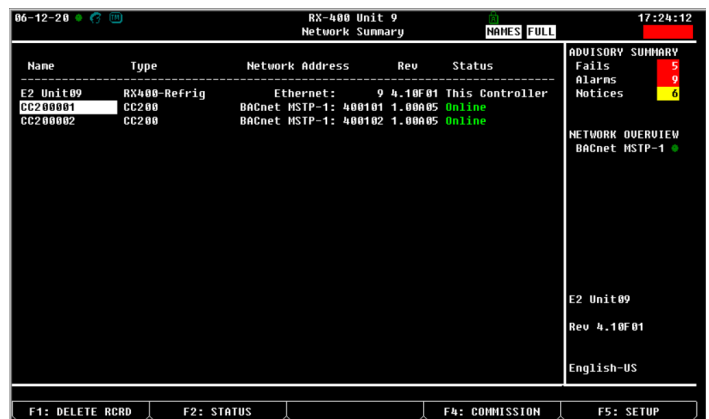

7.5 E2 Modbus Setup

CC200 version 1.01F01 or later is capable of communicating via Modbus with E2E version 4.10F01 or higher. CC200 1.01F01 or later can communicate via Modbus with any version of E3 or Site Supervisor Controllers.

Communication between E2E and the Case Controller takes place using a Modbus RS485 daisy chain network. Follow the instructions in [Section 6.4, BACnet Router RS485 Specifications](#) to connect a CC200 to the E2E network and comm plug connector. Then follow the instructions in this chapter to set up the CC200 in the E2E. An E2E has up to three COM ports that can be assigned for Modbus communication: COM2, COM4 and COM6 are the available RS485 ports on the E2E power interface board. The CC200 Modbus daisy chain can be connected to any available E2E comm port: **2a**, **2b**, **6**, **4a** or **4b**.

Modbus Comm Port Setup

Before setting up a CC200 in the E2E, decide which comm port will have the Modbus daisy chain connected to it. Then set up this port as Modbus in the E2E.

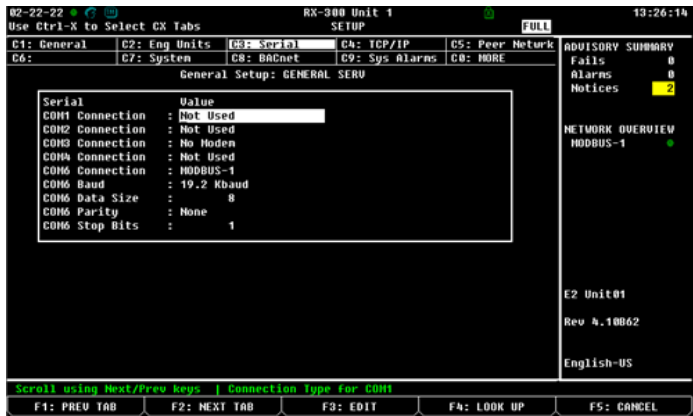

1. Log into the E2E with level 4 access or higher.
2. Press **Alt** + **M** on the keyboard to access the Serial tab of the General controller setup screens.





3. This screen will have a connection field for all available COM ports on the E2E. Highlight the COM port connection you will be using for Modbus and press **F4** :LOOK UP and select **Modbus -1** from the list of network types.
4. Four fields will become visible underneath the COM port connection field, which pertain to the way the device communicates:
 - a. **Baud** - Default setting is 19.2k. (All devices connected to the same COM port should be set to the same baud rate.)
 - b. **Data Size** - Leave this field at the default value (**8**).
 - c. **Parity** - Leave this field at the default value (**None**).
 - d. **Stop Bits** - Leave this field at the default value (**1**).
5. Press  to save changes and exit.

Add and Connect CC200 Devices

To enable communications between the E2E and the Case Controllers, the devices must be added to E2E and addressed.

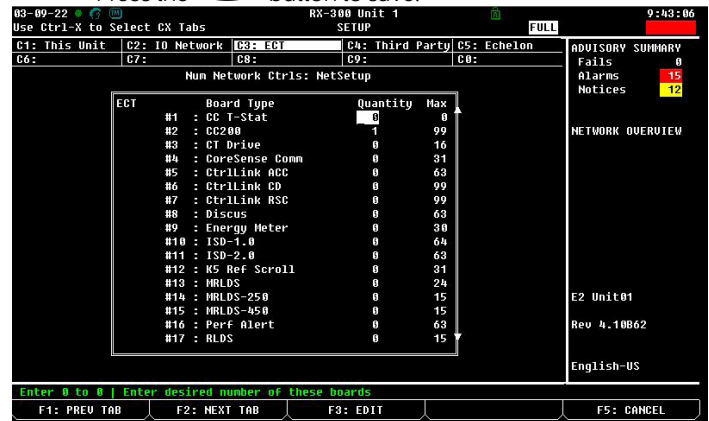
1. Log into the E2E with level 4 access or higher.
2. Press , **7**, **7**, **3** to access Connected I/O Boards and Controllers.
3. In the Connected I/O screen under the ECT tab, enter the number of Case Controller devices in the Quantity field. Press the  button to save.



4. Press the  button to return to the home screen.
5. Press **Alt** + **N** on the keyboard to access the Network Summary screen.
6. The number of Case Controller units added in Step 3 should now be visible in the Network Summary screen.

Commissioning the CC200 in E2E

1. Log into E2E.
2. Press **Alt** + **N** to reach the Network Summary screen, CC200 devices that have not yet been commissioned will say **No Port** in the status column.



5. A screen will appear to confirm the Physical Address of the device. Press **Enter** and the text **MODBUS Device Address** is set will appear.



3. Highlight the first device to address and press **F4**: **COMMISSION**. A screen will appear with a list of Modbus addresses. If a controller name as already been assigned to a Modbus address, the name will appear next to the left of the Modbus address number.
4. Select the Modbus address of the device and press **Enter**.

6. Press **Esc** button to return to the network summary screen.
7. The CC200 Status field in Network Summary should transition from **Unknown** to a green **Online** status indicating successful communication is taking place.

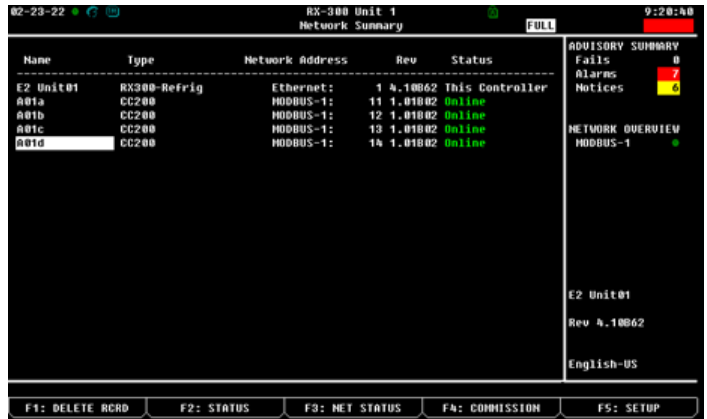
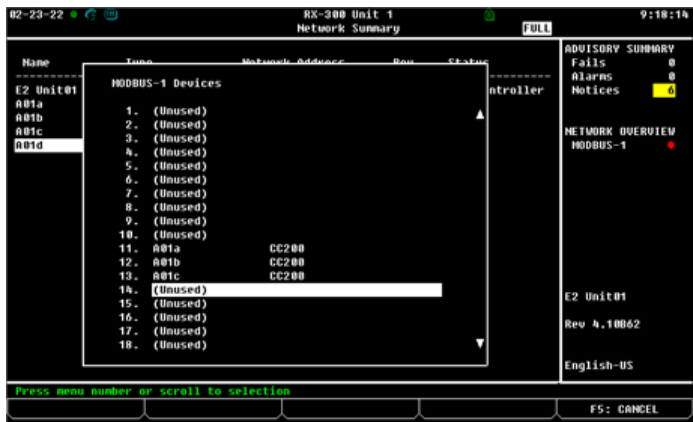

8. E3 Setup - BACnet and Modbus

The CC200 Case Controller is capable of communicating BACnet with the E3 Controller using an ADF. Using the Case Controller with E3 offers the following benefits over using the Case Controller as a stand-alone device.

- Connect CC200s to E3 CO₂ Suction Group application for seamless circuit load startup/shutdown.
- Remotely upgrade firmware of the CC200.
- Reporting of case controller-related alarms.
- The ability to log case controller data in an E3 logging group or run a real-time graph on case controller data points.
- The ability to shut down refrigeration for walk-in boxes in event of a refrigerant leak event (available if a leak detection panel is used).
- Remote access to case controller status and programming from the E3 front panel.
- The ability to remotely access the case controllers using Connect+.

8.1 BACnet E3 Setup for MS/TP-IP Router Networks

When using CC200 MS/TP-IP Router topology, BACnet communication between E3 and the Case Controller takes place over the RS485 BACnet MS/TP network using E3 comm ports. To prepare case controllers to communicate with E3, set BACnet parameters with the display as outlined in [Section 6.3, BACnet Router RS485 Detail](#) or with the Cold Chain Connect mobile app as outlined in [Section 9.6, How to Set Parameters](#). Follow the instructions in this chapter to set up the Case Controller in the E3.

An E3 has up to **four (4)** COM ports that can be assigned for BACnet MS/TP communication: **COM1 - COM4**, are the available RS485 ports on the E3 power interface board. For E3 serial ports with an A and B connector, CC200s must be connected to the **A connector** only.

BACnet COM Port Setup

Before setting up a Case Controller in the E3, the serial port that has the BACnet MS/TP cable connected to it must be set up as a BACnet MS/TP port.

1. Log into the E3.
2. Click the **Main Menu**  icon to bring up the main menu, select **General System Properties**.
3. Select the **COM Ports** tab and select the COM port which the CC200 network cable is wired to. Configure the following BACnet settings for the port:

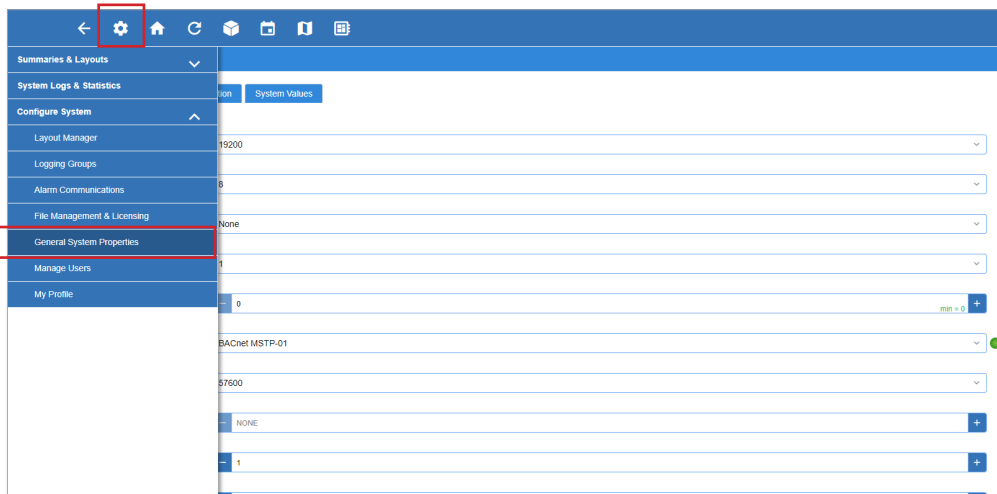

- **COM Port Baud** - Default setting is **9600**; this must be changed to **57600** on the E3 and the CC200 configured as the BACnet router (all devices connected to the same COM port should be set to the same baud rate).
 - **COM Port Device Id** - This is the E3 BACnet Device ID; set this to a unique number from all other BACnet nodes on the network in the range of **0-4194303**.
 - **COM MSTP MAC** - This is the E3 BACnet MSTP MAC address; set this to a unique number for E3 in the range of **0-127**. Each BACnet device on the network must have its own unique MSTP MAC in order to communicate.
 - **COM Port 1 Max Info Frames** - set to **36** for E3 to CC200 communication
4. Click **Save** and proceed to adding and connecting case controllers in the next section.

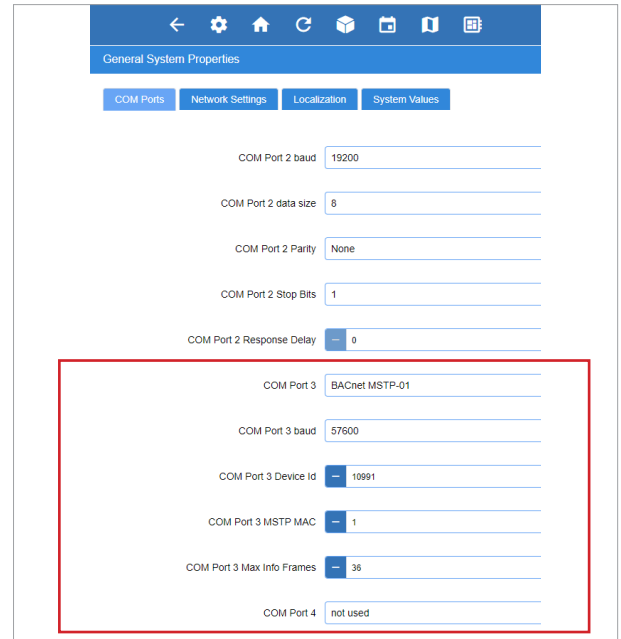

8.2 BACnet E3 Setup for ETH 1 IP Network

When using BACnet IP to E3 Ethernet port 1, follow the guidelines in [Section 6.2, BACnet IP with E3 Ethernet Ports](#) and the instructions here on how to setup E3 ETH 1 port. E3 must be running version 2.28F02 or higher and all CC200s planned for the BACnet IP network must be 1.03F01 or higher. Follow the instructions in [Section 6.5, Configuring BACnet Settings on the CC200 Case Display](#) to setup CC200 BACnet device ID and IP address.

To configure E3 ETH 1 port for CC200 BACnet IP:

1. Log into the E3, the **Main Menu** icon to bring up the main menu, select **General System Properties**.
2. Select the network settings tab then the ETH 1 tab. Click advanced in the top right to show ETH 1 and PIB network settings
3. Configure **ETH 1 Subnet Mask** to **255.0.0.0** and **PIB Network Subnet Mask** to **255.0.0.0**
CC200 controllers default to subnet mask is **255.0.0.0** out of the box. Octet 1 of CC200 IP address is adjusted to 192 per the instructions in [Section 6, The BACnet Network](#) of this manual. Press **Save** to complete the changes.
4. Go to the BACnet tab with advanced button still toggled on.
 - a. Set a unique BACnet device ID for ETH 0 and ETH 1.
CC200 device ID's start in the 10,000 range and increase from there. Using a value well below 10,000 for E3 is safe.

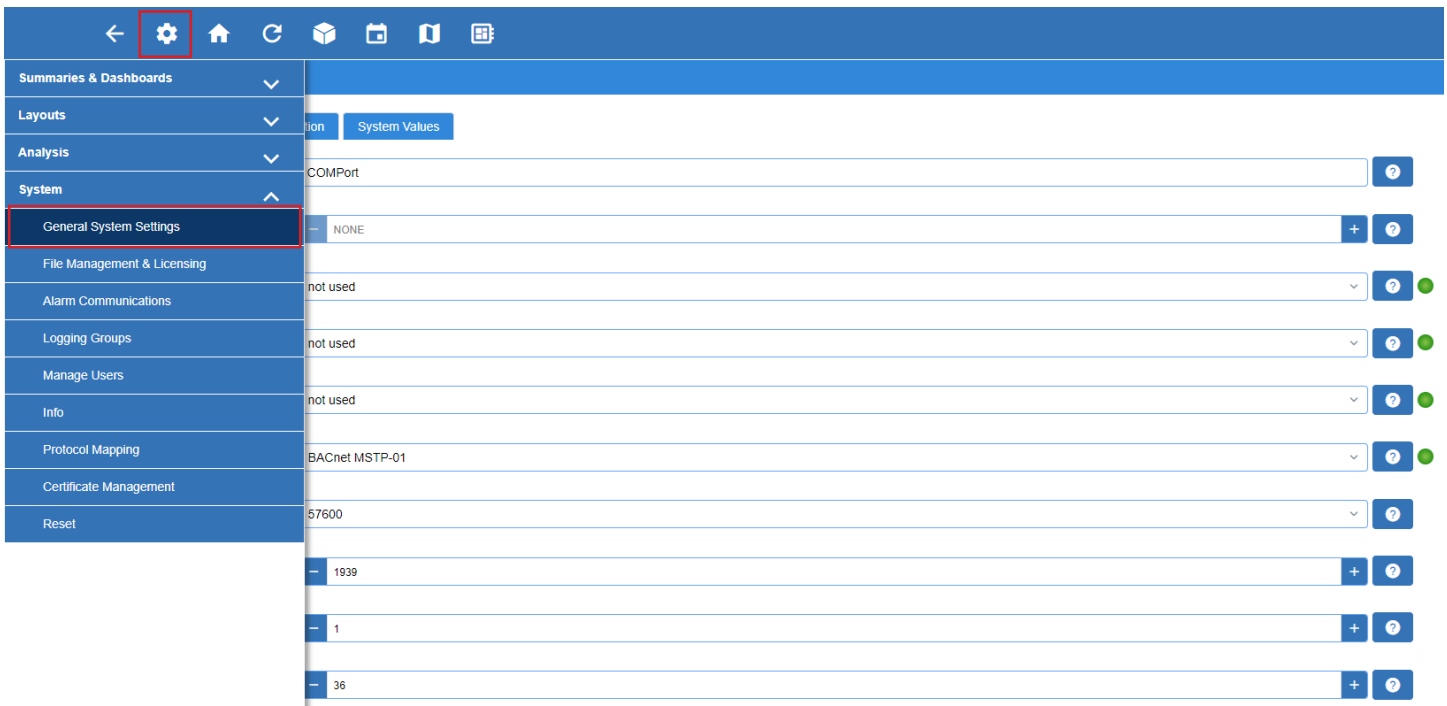

b. ETH 0 and ETH 1 BACnet Port should stay at **47808**.

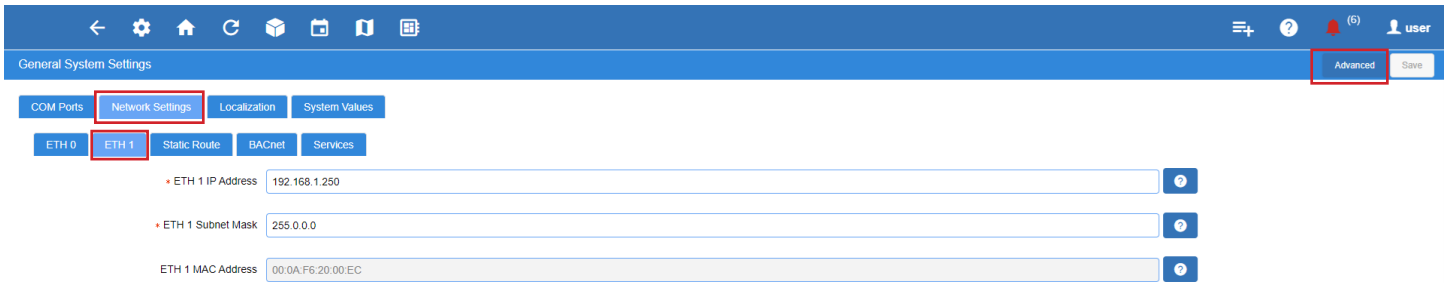

c. Time sync period controls the frequency in minutes at which E3 will send a BACnet time sync broadcast message. Set at **1440** minutes, it may be adjusted to a shorter value such as 5 minutes when bringing new case controllers online in order to force a faster time sync but should be left at 1440 for long term usage.

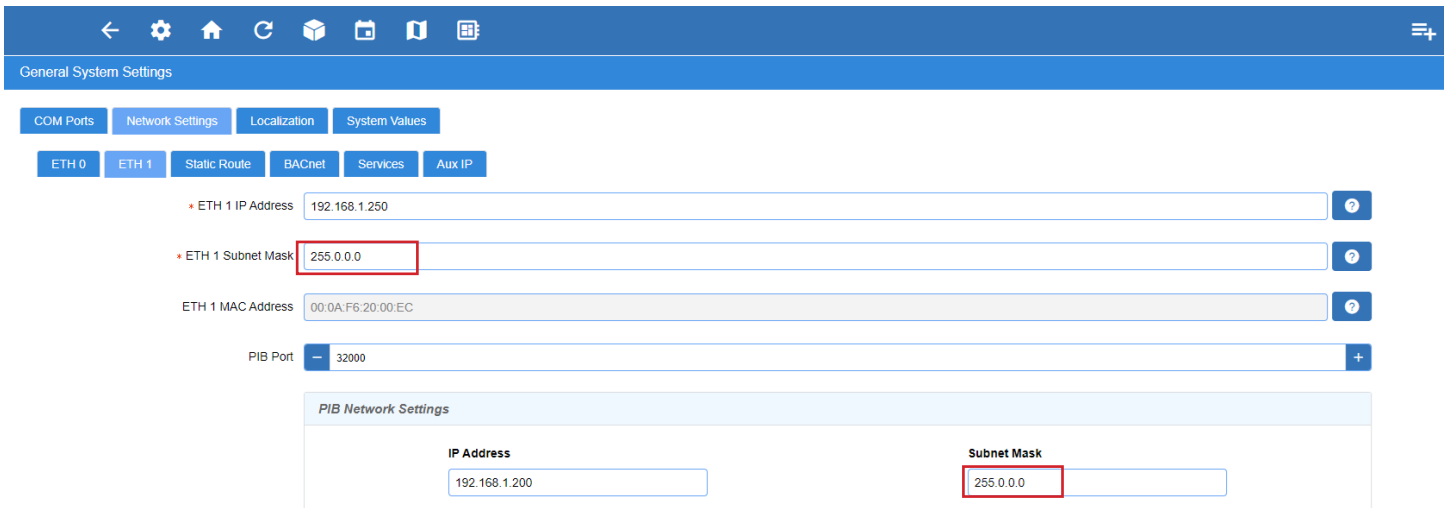

d. Leave all other parameter at defaults unless there are other MS/TP devices on RS485 comm ports that require specific max master, max info frames, and APDU settings.

5. Follow the steps in [Add and Connect Case Controllers](#) to add CC200s and bring them online with E3. At the step where the Port ID is selected, choose BACnet IP-ETH1 and then start the scan to discover available case controllers.

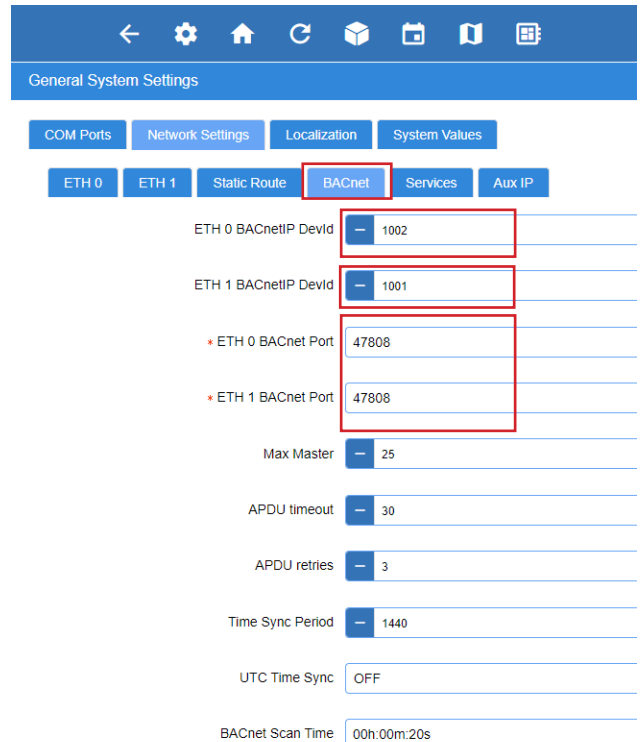

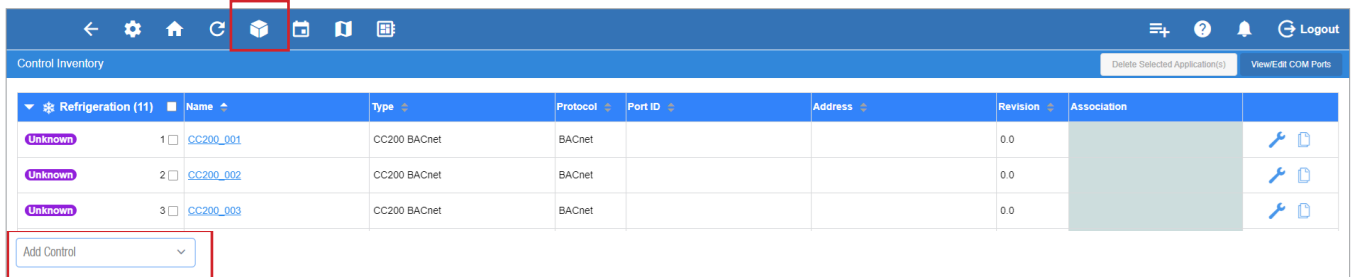

Add and Connect Case Controllers

1. Click the **Control Inventory**  icon, expand the refrigeration section use the **Add Control** box to select CC200 BACnet as controller type. The Protocol field will automatically configure to BACnet.

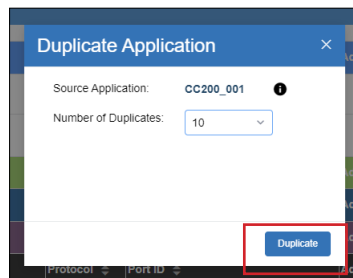
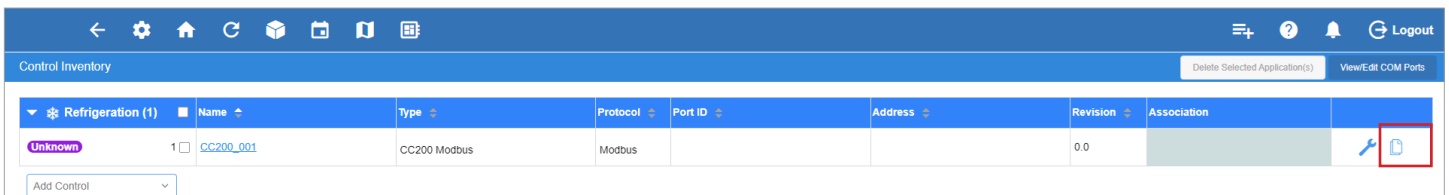

2. Select the **Duplicate**  icon and enter the number of copies needed to add the desired amount of CC200 controllers to E3. Click **Duplicate** to proceed.



3. Once the desired quantity of controllers have been added, click the wrench  icon to commission each case controller.

Select the BACnet Port ID for the CC200 network you wish to bring online. A scan will start to discover available BACnet CC200s on the serial port.

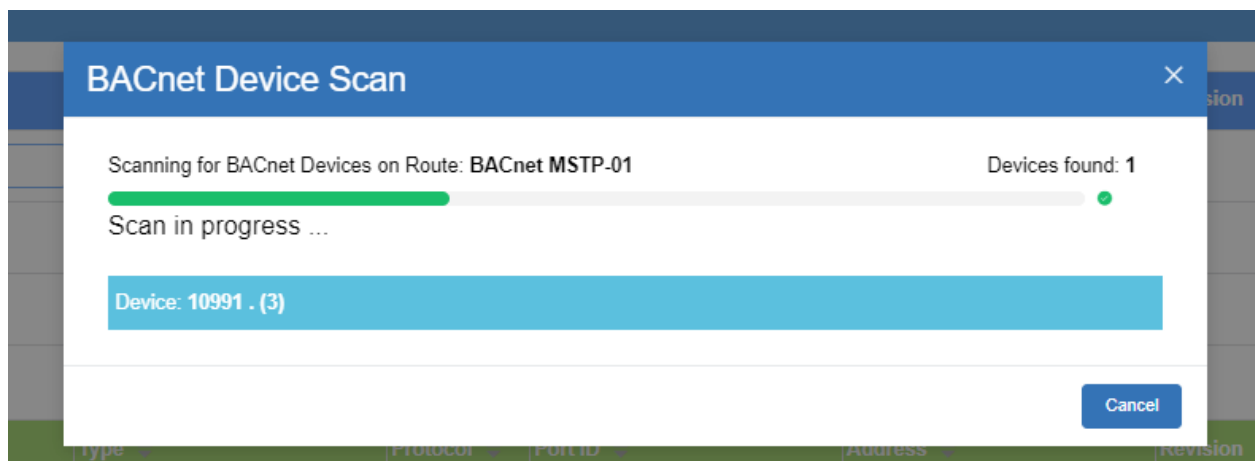

- After the scan completes, select the corresponding address for each case controller in the address column drop down box.

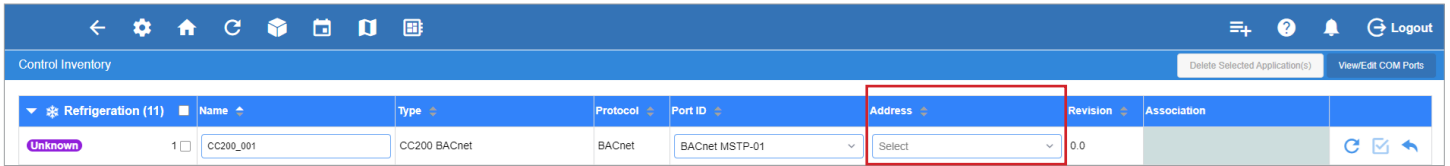

- Click the check box to confirm the address, the case controller should transition from **Unknown** to **Online**.

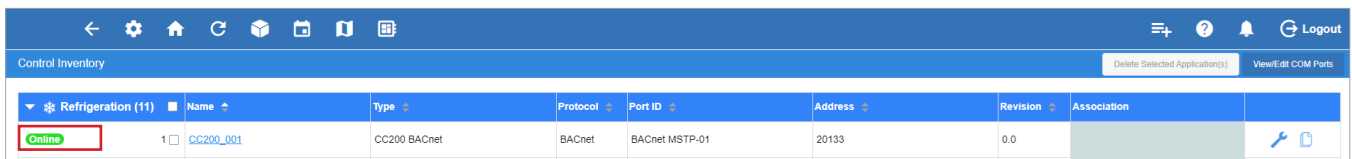
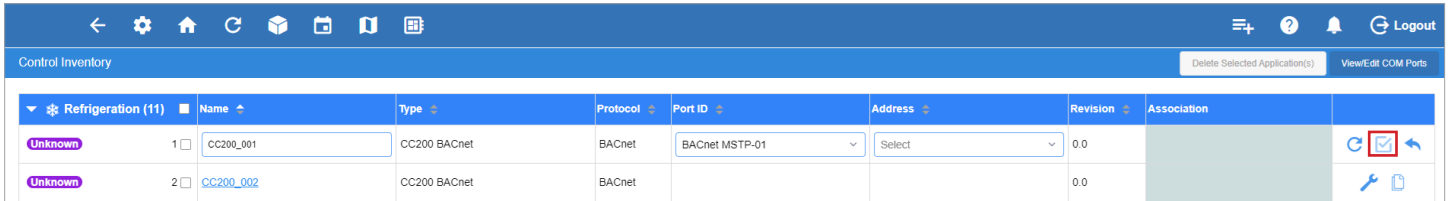

- Repeat steps 4 and 5 for the remaining case controllers, setting the corresponding address for each.

NOTICE

After a scan for devices, for a sorted list of CC200s, go to the home page and then return to the Control Inventory page.

8.3 Modbus E3 Setup

CC200 version 1.01F01 can communicate via Modbus with any version of E3 or Site Supervisor Controllers. Communication between E3 and the Case Controller takes place using a Modbus RS485 daisy chain network. Follow the instructions in [Section 6.4, BACnet Router RS485 Specifications](#) to construct the CC200 to E3 daisy chain network.

[Section 6.5, Configuring BACnet Settings on the CC200 Case Display](#) covers how to configure Modbus settings using the display and [Section 9.6, How to Set Parameters](#) covers how to configure settings with the Cold Chain Connect mobile app. The instructions in this chapter outlines how to add and commission CC200s on E3. An E3 has up to **four (4)** COM ports that can be assigned for Modbus: COM1 (A or B), COM2, COM3, and COM4 (A or B) are the available RS485 ports on the E3 power interface board. The CC200 daisy chain can be connected to any available E3 COM port.

Modbus COM Port Setup

Before setting up a CC200 in the E2E, decide which COM port will have the Modbus daisy chain connected to it. Then set up this port as Modbus in the E3.

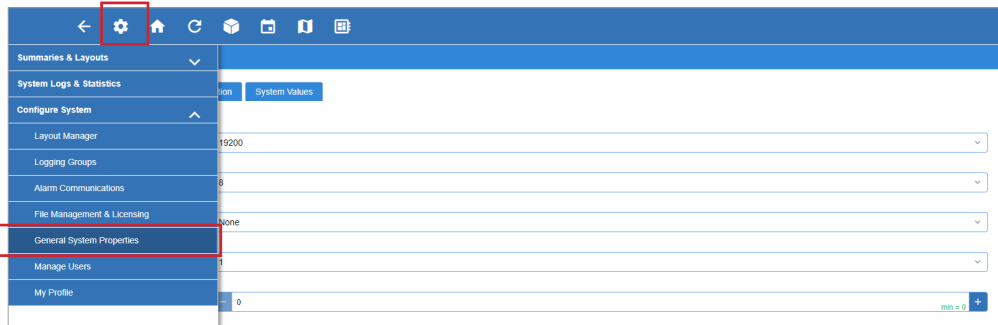

1. Log into the E3.
2. Click the **Main Menu**  icon to bring up the main menu, select **General System Properties**.

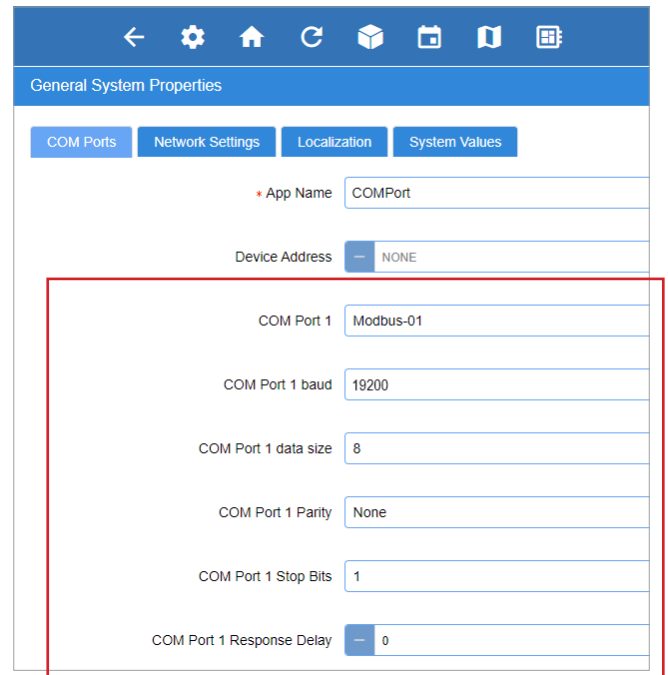

3. Select the **COM Ports** tab and select the COM port which the CC200 network cable is wired to. Select an available Modbus protocol for the port and configure the following settings.
 - a. **Baud** - Default setting is **9600**, change to **19200** for maximum amount and best performance of CC200 devices on a single daisy chain.
 - If CC200 is mixed with other device types on the daisy chain, match the CC200 baud rate to the slower devices.
 - If CC200 is the only device type on the entire daisy chain, select **19200** as the baud rate for CC200s and E3 to achieve maximum number of devices and optimal performance.
 - b. **Data Size** - Leave this field at the default value (**8**).
 - c. **Parity** - Leave this field at the default value (**None**).
 - d. **Stop Bits** - Leave this field at the default value (**1**).
 - e. **Response Delay**- Leave this field at the default value (**0**).
4. Click **Save** and proceed to adding and connecting case controllers in the next section.



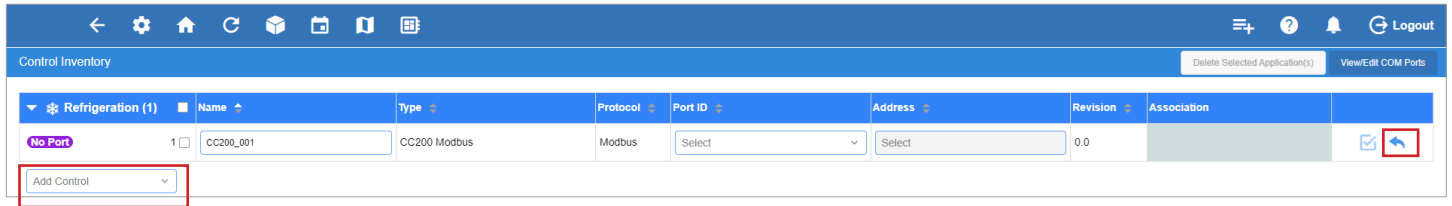

Add and Connect Case Controllers

- Click the **Control Inventory**  icon, expand the refrigeration section and use the **Add Control** box to select the CC200 Modbus as the controller type. The Protocol field will automatically configure to Modbus. Click the arrow  icon to save the first controller added.

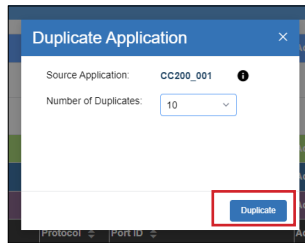
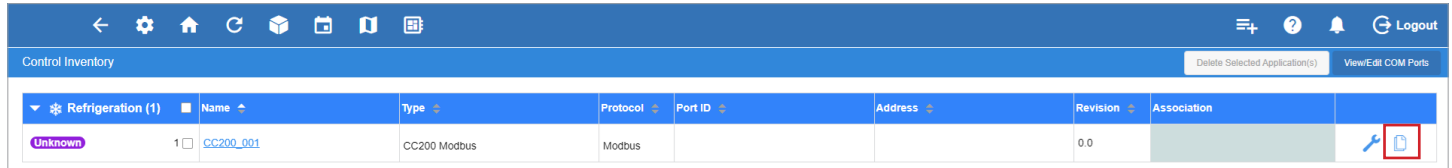

- Select the **Duplicate**  icon and enter the number of copies needed to add the desired amount of CC200 controllers to E3. Click **Duplicate** to proceed.



- Once the desired quantity of controllers have been added, click the wrench  icon to commission each case controller. In the **Port ID** box select the Modbus protocol set up in a previous step. Use the box under the **Address** column to set the Modbus address of each CC200 controller.

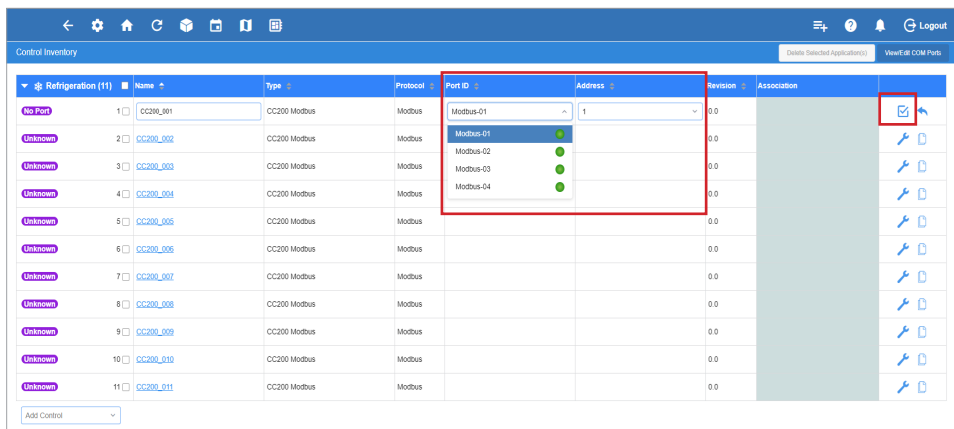

- Click the checkbox to confirm the address, the case controller should transition from **Unknown** to **Online**.

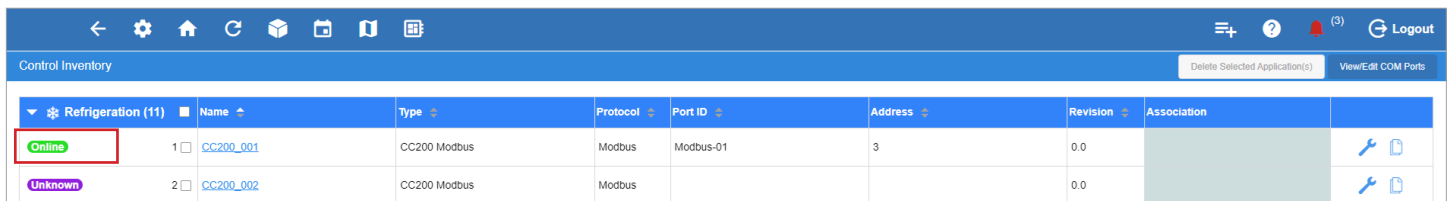

- Repeat steps 4 and 5 for the remaining case controllers, setting the corresponding address for each.

9. Cold Chain Connect Mobile Application

Cold Chain Connect is a mobile application for connecting to the Copeland CC200 refrigerated case controller. This section is a guide for using the Cold Chain Connect App to set parameters, graph inputs and outputs, set service overrides, and view alarms. Cold Chain Connect provides a window into CC200 operation and diagnostics directly at the location of the refrigerated fixture or walk-in box.

9.1 Download the Cold Chain Connect Application

- Visit the App Store® and download the Cold Chain Connect App for iOS.
- Visit the Google Play Store and download the Cold Chain Connect App for Android™.



Scan the QR code for the Cold Chain Connect App.



Scan the QR code for the Cold Chain Connect App.



9.2 Register the App

- Select **New User? Register**.
- Fill out all the required fields and press **Register**.
- You will receive an email once your account has been activated.

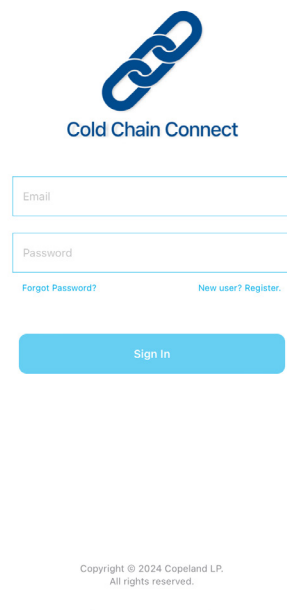

The registration screen features the Copeland logo at the top, followed by the text "Cold Chain Connect". Below this are two input fields: "Email" and "Password". Under the "Password" field, there are two links: "Forgot Password?" and "New user? Register.". A blue "Sign In" button is positioned below the input fields. At the bottom of the screen, the copyright notice "Copyright © 2024 Copeland LP. All rights reserved." is displayed.

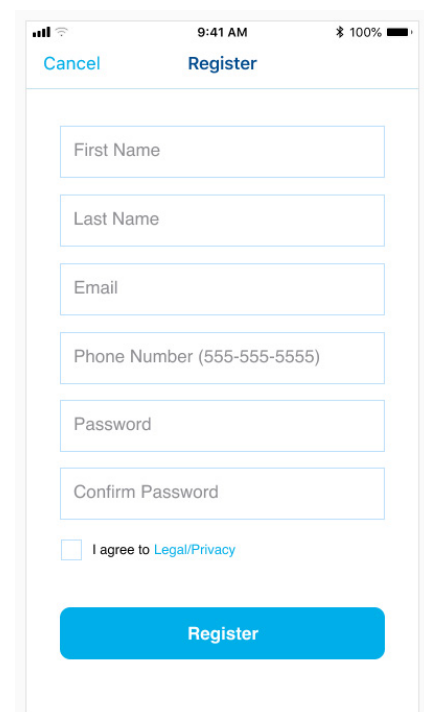

The mobile registration screen shows a "Cancel" link and a "Register" button at the top. The form includes input fields for "First Name", "Last Name", "Email", "Phone Number (555-555-5555)", "Password", and "Confirm Password". A checkbox labeled "I agree to Legal/Privacy" is located below the "Confirm Password" field. A blue "Register" button is at the bottom of the form.

9.3 How to Activate Bluetooth® on the CC200 Case Display

- a. **Step 1: Unlock Screen:** Press and hold for three seconds on the top right corner of the screen. Once the Display is unlocked, **SET** will be visible in the bottom left corner and **PRG** will be visible in the top right corner:

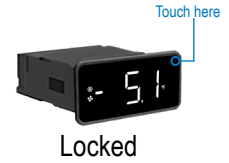

NOTICE After 5 minutes with no touch activity, the Display keyboard locks automatically.

- b. **Step 2: Virtual Keyboard:** Swipe left or right to navigate to the virtual keyboard:
- c. **Step 3: Turn ON Bluetooth®:** From the virtual keyboard, press and hold the Bluetooth® icon on the top right corner for three seconds.



- d. Once Bluetooth® is activated, a small Bluetooth® status icon in the lower right corner of the Display will begin to blink slowly, indicating the CC200 is ready for connection. The Bluetooth® status icon turns solid when Cold Chain Connect is actively connected.



NOTICE After 10 minutes with no connection from Cold Chain Connect, Bluetooth® on the CC200 switches off automatically.

9.4 Connecting to a Case

- a. Once the CC200 Bluetooth® is ON (refer to Step 3) and the Bluetooth® icon is blinking slowly, the CC200 is ready to connect to the Cold Chain Connect App.
- b. Turn Bluetooth® ON the mobile device or tablet. Open Cold Chain Connect and sign in. After signing in, Cold Chain Connect will scan for nearby CC200 controllers and available controllers will be displayed as shown in the below graphic.

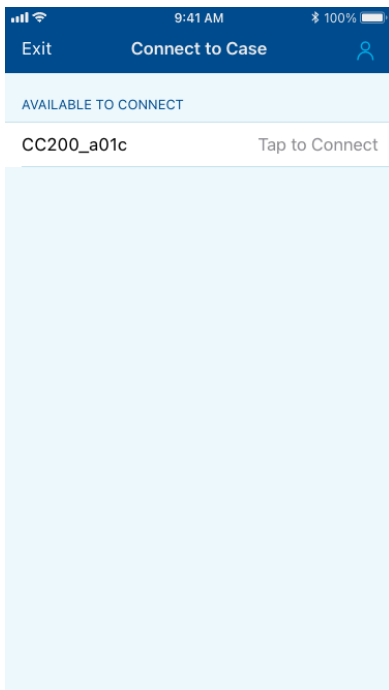

9.5 Information on the Case Tab

Once a connection with a CC200 has been established, the Case tab will appear with CC200 status information and available service commands.

- Case Temp
- Case Superheat
- Status of the relay outputs
- Overrides
- Presures
- Alarms

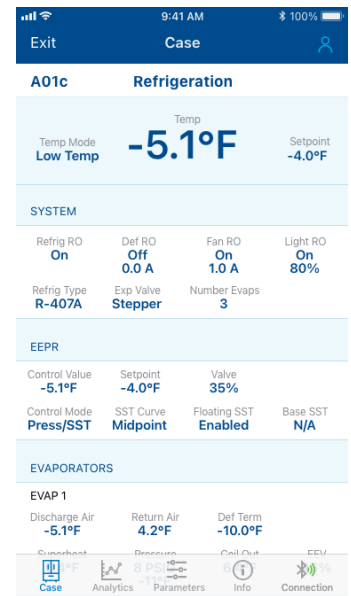
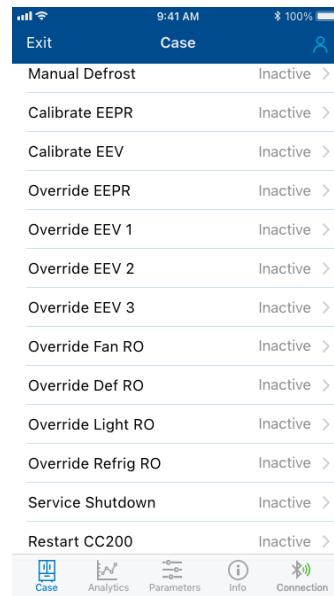

9.6 How to Set Parameters



- Select the **Parameters** tab at the bottom of the application.
- On the Parameters screen, a list of parameter groups is shown.
- Touch the first group name to enter the group and begin the configuration process.
 - Each group will have a list of parameters and a description. The current value of the parameter is shown in blue to the right of the name.
- Touch the first parameter in the group to bring up the edit control.
 - Enter the desired value and press **Done**. The new edit will be displayed above the original value of the parameter.
- Edit all the desired parameters within the group.
 - Press **Save** in the top right corner of the Group screen.
 - Repeat the procedure for all the groups.

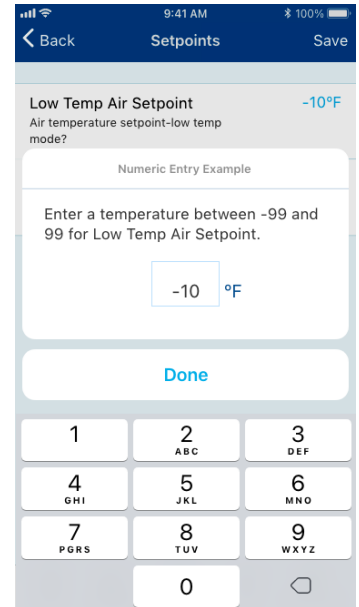
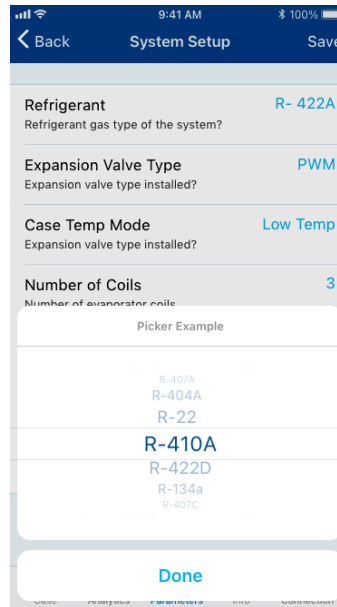

NOTICE

Pressing Back discards any edits selected for that group and they will not be saved to the CC200.

9.7 Manual Defrost

- From the dashboard, scroll down to **COMMANDS**.
- Select **Manual Defrost**.
- A pop-up will appear with two options:
 - Manual Defrost**
 - This option puts the CC200 into a defrost cycle immediately. The CC200 will terminate the defrost according to the programmed defrost parameters as if it were a normally scheduled defrost cycle.
 - Emergency Defrost**
 - This option puts the CC200 into a defrost cycle immediately; however, the CC200 will run the defrost cycle for the maximum period of time programmed in the defrost parameter group.
- To cancel the **Manual Defrost** or **Emergency Defrost**:
 - Select **Manual Defrost** again and now, a pop-up window to End Manual Defrost will appear. Select **End Manual Defrost** and the defrost is now cleared.

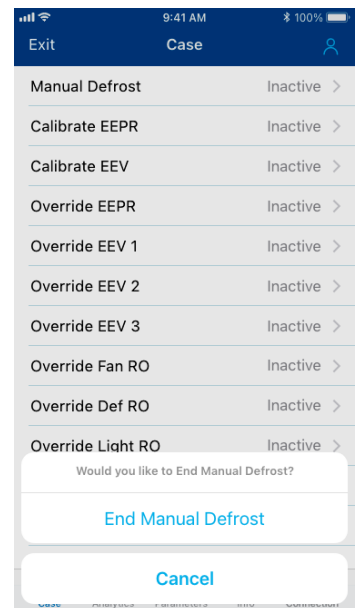
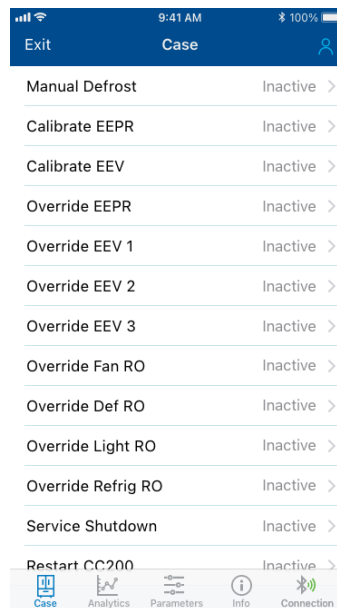

9.8 Calibrate Valve

- From the dashboard, scroll down to **COMMANDS**.
- Select Calibrate **EEPR**.
- The valve will start calibrating.

NOTICE The calibration cannot be stopped once it has started.

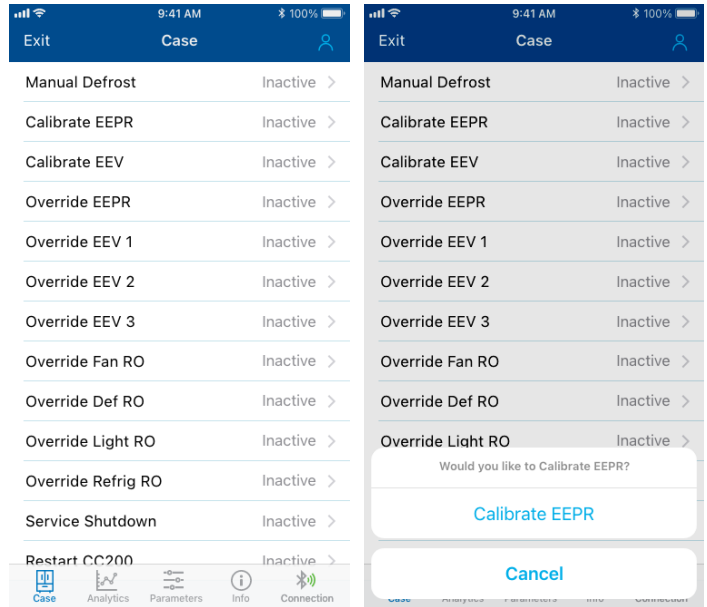

9.9 Overrides

- From the dashboard, scroll down to **COMMANDS**.
 - You will see a list of overrides that can be manually configured.
 - All overrides are timed and with a maximum time of 10 minutes.
- Select the desired override to enter on the Override screen.
- In the Override screen, toggle the switch and two new fields will become visible.
- Select the override value and length of time. A maximum time duration of 10 minutes is allowed for all overrides.
- Once a value and length of time have been chosen, press **Save** to set the override. The override can be changed at any time by re-entering the screen, choosing a different value, and pressing **Save**.
- Active overrides will be highlighted blue in the dashboard for easy identification.
- To cancel an active override, tap the override from the main Case tab. Turn off the green toggle switch and press **Save**.

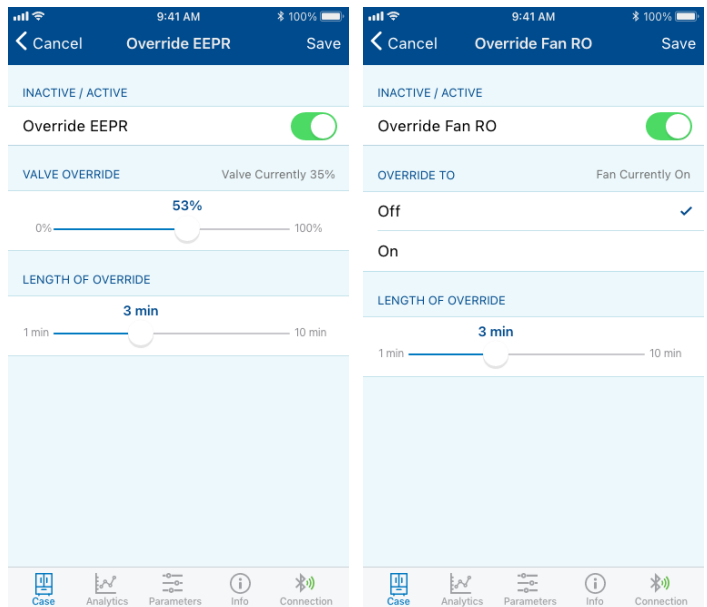

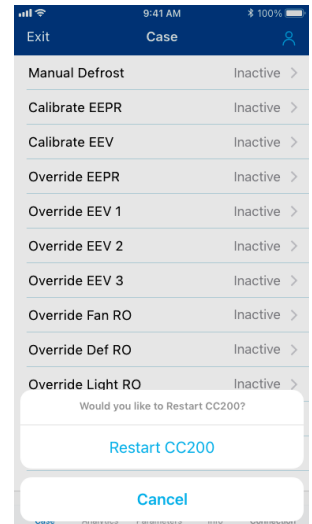

9.10 Restart the CC200

For convenience and service there is a command to reboot the CC200. To reboot the CC200, select the **Restart CC200** command from the list. A pop-up will be shown to confirm the action. The CC200 will perform a soft reboot and status information will be temporarily unavailable in the Cold Chain Connect dashboard.



9.11 Real-Time Graphs

- Select the **Analytics**  tab at the bottom of the application.
- Select **Filter**  at the top of the application.
 - Select the desired values to graph from the list of available CC200 data points and press **Apply**. Cold Chain Connect will begin building the graph.
 - A maximum of two analog data types and two ON/OFF data types can be graphed simultaneously. Tap the graph line anywhere to see a plot marker of the value at that point in time.
- Select **15 mins** and you will be able to select three options:
 - 5 minutes
 - 10 minutes
 - 15 minutes
- Select **Share**  at the top of the application.
 - You will be prompted to share the graph.

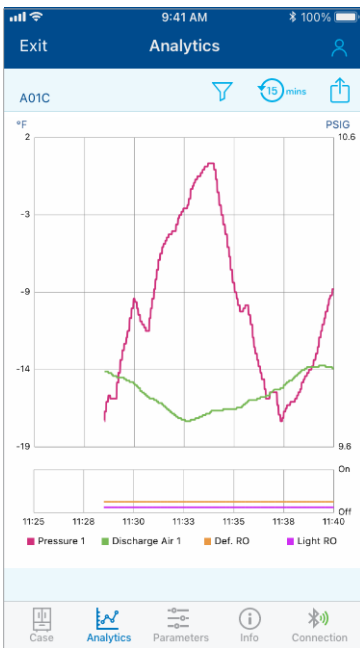

Choose up to 2 analog values to graph.

<input type="checkbox"/> Discharge Air 1	<input type="checkbox"/> Return Air 1
<input type="checkbox"/> Discharge Air 2	<input type="checkbox"/> Return Air 2
<input type="checkbox"/> Discharge Air 3	<input type="checkbox"/> Return Air 3
<input checked="" type="checkbox"/> Def Heater Amp	<input type="checkbox"/> Superheat 1
<input type="checkbox"/> Def Term 1	<input type="checkbox"/> Superheat 2
<input type="checkbox"/> Def Term 2	<input type="checkbox"/> Superheat 3
<input type="checkbox"/> Def Term 3	<input type="checkbox"/> Active Air SP
<input type="checkbox"/> Coil Out 1	<input type="checkbox"/> EEPR Position
<input type="checkbox"/> Coil Out 2	<input type="checkbox"/> EEPR Setpoint
<input type="checkbox"/> Coil Out 3	<input type="checkbox"/> EEPR Ctrl Valve
<input type="checkbox"/> Fan Amp	<input type="checkbox"/> EEV 1 Position
<input type="checkbox"/> Pressure 1	<input type="checkbox"/> EEV 2 Position
<input type="checkbox"/> Pressure 2	<input type="checkbox"/> EEV 3 Position
<input type="checkbox"/> Pressure 3	<input checked="" type="checkbox"/> Superheat SP

Choose up to 2 binary values to graph.

<input checked="" type="checkbox"/> Def RO	<input type="checkbox"/> Light RO
<input checked="" type="checkbox"/> Fan RO	<input type="checkbox"/> Refrig RO

Cancel **Apply**

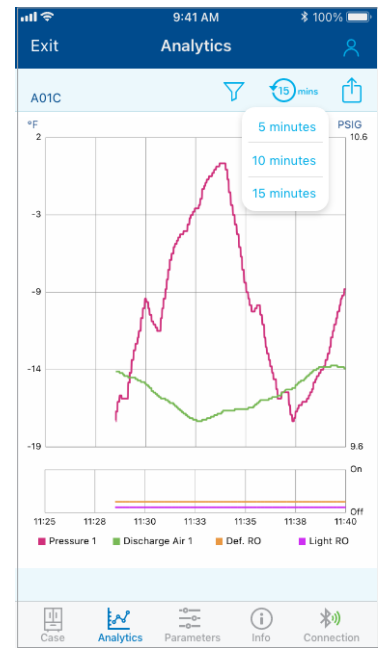

9.12 Viewing Alarms

Active CC200 alarms can be viewed in the Case tab by tapping the alarm icon in the upper right corner of the Case screen. When one or more alarm conditions are active, the alarm icon will be red, if there are no active alarms the icon will be gray and the count will be zero.

An alarm icon will appear next to any piece of data in the Case tab that has an active alarm. Tap the icon next to the data point to see the description.

5 Alarms

- Coil Inlet Sensor Error**
Failed sensor or bad wiring.
- Fan Motor command Failure**
Fan motor failed to start/stop running when commanded or stopped during operation.
- Expansion Module 1 Offline**
No communications detected with expansion module 1.
- Expansion Module 2 Offline**
No communications detected with expansion module 2.
- Expansion Module 3 Offline**
No communications detected with expansion module 3.

Okay

9.13 Info

- a. Select **Info**  at the bottom of the application and you will see the Store info, CC200 version, and the Cold Chain Connect version:

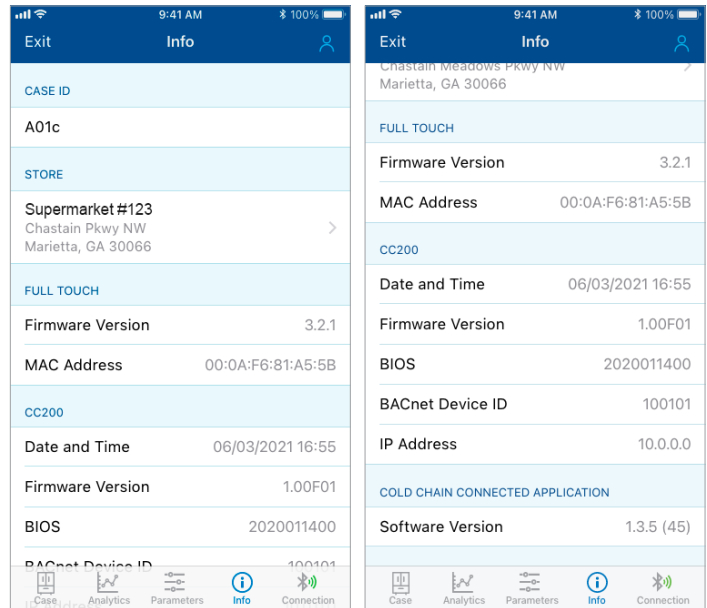

9.14 Disconnect from the Case

- a. Select **Connection**  at the bottom of the application.
- You will see a pop-up window asking you to Disconnect.
 - Select **Yes, Disconnect** and you will be disconnected from the Case.

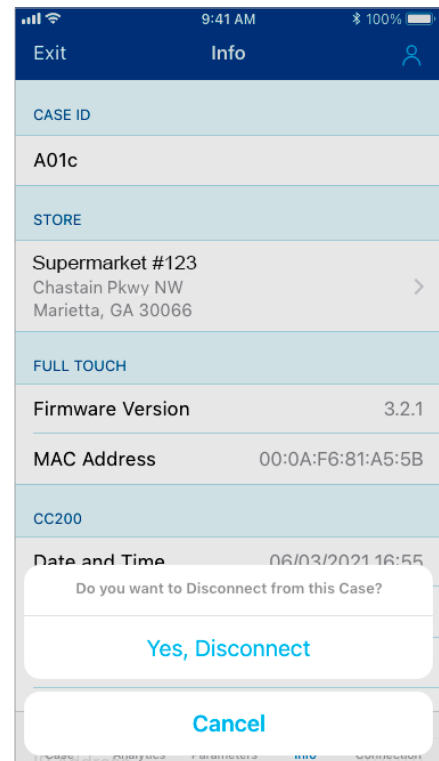

10. Configuring CC200 Parameters

The Cold Chain Connect mobile application provides the ability to quickly configure all CC200 parameters from your mobile device or tablet. In most installations the CC200 will arrive from the factory already configured for the walk-in or case it will be controlling. If on-site configuration is required, the table and figure below will explain the configuration process. Access and navigation of the Cold Chain Connect application is covered in [Section 9, Cold Chain Connect Mobile Application](#).

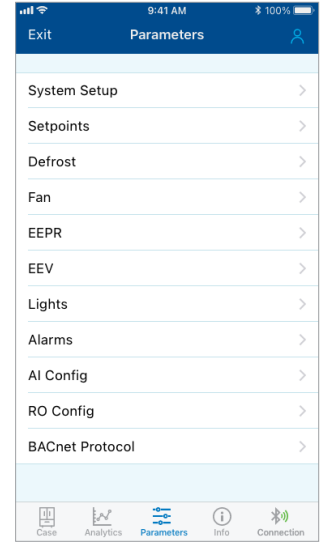

1. Connect to the CC200 to be configured and navigate the parameters tab .
2. The list of parameter groups is displayed.
3. Tap on **System Setup** to begin configuration, set the value of each parameter according to the system requirements and recommended action shown below. Push save at the top of each group once edits have been made.

System Setup	
Parameter	Recommended Action
Refrigerant	Select the refrigerant type for the system installation.
Expansion Valve Type	Select the type of expansion valve that is installed in the system. TEV = Thermostatic Expansion Valve TEV SH Monitor = TEV with superheat monitoring. CC200 will expect pressure sensors and coil outlet sensors to monitor each coil's superheat. Stepper EEV = Stepper motor electric expansion valve. CC200 will control superheat by positioning the stepper valve EEV. PWM = Pulse width modulated expansion valve, CC200 will control superheat by controlling a PWM expansion valve.
Cases In Lineup	Specifies the number of cases in the refrigeration lineup. For cases connected in a lineup, enter the number of cases in the lineup. Enter 1 for cases that are stand-alone and not part of a lineup.
Case Temp. Mode	Select the type of temperature application for the case or walk-in box. Dual temperature cases should select Dual, CC200 will shift between low and medium setpoints for dual temperature cases.
Number of Coils	Select the number of evaporator coils installed in the system.
Continuous Refrigeration	No = REFRIG RO on the controller relay outputs will cycle on/off with air temperature setpoint and deadband. Yes = REFRIG RO stays on constantly during refrigeration except for during defrost and service or leak shutdowns. Note: A value of Yes should be selected for systems using EEPR. A value of Yes should be selected for systems using PWM or Stepper EEV control.
LLSV Present	Select if a liquid line solenoid is wired to REFRIG relay output.
Control Sensor	Select the type of air sensor used to control air temperature in the case or walk-in. Typically discharge air is selected for cases and return air is selected for walk-in boxes.
Case Temp. Combination	For multi-coil cases or walk-in boxes with more than one air sensor installed, a combination method is applied to the value of all the sensors. The combined value is then passed to control logic for controlling the air temperature. Typically, the average is selected.
PWM Valve Period	Enter the period for the PWM valve. Enter the value from the PWM EEV OEM data sheet.
PWM Short Cycle	This is the PWM Valve minimum control % and prevents short cycle of valve by limiting the minimum ON time of Valve during the Pulse Period. The upper control percent is 100%. The control value will be linear from PWM Short Cycle to (100% - PWM Short Cycle). To obtain maximum capacity, the PWM valve percentage will step from (100% - PWM Short Cycle) to 100% to prevent short cycle of valve at top end of control range (limits minimum OFF time of Valve during the Pulse Period).

- Once System Setup parameters are set and saved, tap on the Setpoints group. Set the value of each parameter according to the system requirements and recommended action shown below:

Setpoints	
Parameter	Recommended Action
Low Temp. Air Setpoint	Enter the low temperature air setpoint that the case or walk-in box temperature should be regulated to. The case will operate on this setpoint when Case Temp Mode is set to low or when set to dual and the dual temperature input is in low temp mode.
Medium Temp. Air Setpoint	Enter the medium temperature air setpoint that the case or walk in box temperature should be regulated to. The case will operate on this setpoint when Case Temp Mode is set to medium or when set to Dual and the dual temperature input is in medium temp mode.
Air Setpoint Deadband	This is the deadband for air temperature regulation and is split half above and half below the active air setpoint. When Continuous Refrigeration is set to No , the REFRIG RO on the controller will cycle on/ off based on this deadband and the air temperature setpoint.
Superheat Setpoint	Superheat control setpoint that all evaporators will be controlled to. Enter the superheat setpoint from the case/walk in OEM data sheet
Superheat Deadband	Deadband around superheat setpoint (+/- half) The Copeland default value is sufficient unless adjustments to evaporator performance are required.
Max Pulldown Time	This duration specifies the maximum amount of time the case can remain in a post defrost pulldown.
Door Disables Refrig.	When a door switch digital input is configured, this parameter will determine if CC200 shuts off refrigeration for each door opening. No = Refrigeration will remain on during door openings. Yes = Refrigeration will shut off during door openings and turn back on when door closes.
Door Failsafe Timeout	If Door Disables Refrig. is set to Yes , this parameter defines the maximum amount of time refrigeration can remain off before automatically resuming operation again.

- Once Setpoint parameters are set and saved, tap on the Defrost group. Set the value of each parameter according to the system requirements and recommended action shown below:

Defrost	
Parameter	Recommended Action
Heat Type	Select the type of defrost heat for the case or walk-in. Off Cycle = Refrigeration is turned off, warm air in the case defrosts the evaporator coil. Electric = Refrigeration is turned off, DEFROST RO on the controller is energized to turn on an electric heater.
Defrost Start Time	Enter the start time for the first defrost cycle. Defrost cycles will be spaced evenly through 24 hours based on start time and Cycles Per Day .
Cycles Per Day	Enter the number of defrost cycles in 24 hours.
Termination Type	Select the termination strategy for the case or walk-in box. Maximum Time is respected for all termination types. Time = The defrost cycle will run for the Minimum Time and terminate after the Maximum Time is reached. Temp = The defrost cycle will run for the Minimum Time and terminate once the Termination Sensor reaches the Term. Temp. Setpoint DI = The defrost cycle will run for the Minimum Time and terminate once the defrost termination digital input is On.
Termination Sensor	Select the termination sensor that is installed in the case or walk-in box.
Term. Combination	For multi-coil cases or walk-in boxes there can be one termination sensor per evaporator coil. A combination method is applied to the sensor values to determine the final termination value.
Term. Temp. Setpoint	Enter the manufacturer's recommended setting. When Termination Type is set to Temperature the CC200 will terminate the defrost once the termination temperature reaches this setpoint.
Minimum Time	Enter the manufacturer's recommended setting for defrost minimum time. This is the minimum duration the defrost cycle must run before termination is allowed.
Maximum Time	Enter the manufacturer's recommended setting for defrost maximum time. This is the maximum duration the defrost cycle can run.
Drip Time	Enter the manufacturer's recommended setting for defrost drip time. This is the duration after defrost and before refrigeration or fan resumes to allow moisture to fall into the drain pan.
Pump Down Time	Enter the desired pump down delay time here, if set to 0, no pump down procedure will occur.

6. Once Defrost parameters are set and saved, tap on the Fan group. Set the value of each parameter according to the system requirements and recommended action shown below:

Fan	
Parameter	Recommended Action
Fan In Refrig.	Select if the fan should be continuously on during refrigeration or cut in/cut out. Continuous On =Fan never cycles off during refrigeration. Cut In/Cut Out =Fan cycles off with REFRIG RO when air temperature is satisfied.
Fan In Defrost	Select if the fan should be on or off during defrost.
Delay Method	Select if the fan delay method once refrigeration resumes after defrost. For no fan delay select Time and enter 0 in Delay Time. Time Delay =Fan will be delayed for duration of Delay Time parameter. Coil Temp =Fan will be delayed until the coil outlet sensor drops below the temperature defined in Delay Temp. parameter.
Delay Time	If Delay Method is set to time delay, the fan will be delayed for the duration defined here.
Delay Temp.	If Delay Method is set to coil temp, the fan will be delayed until the coil outlet sensor reaches the temperature defined here.
ECM Present	Determines if an Electronically Commutated Motor type is used for evaporator fan. No = No ECM type used for evaporator fans. Yes =ECM type motors in use for evaporator fans.

7. Once Fan parameters are set and saved, tap on the EEPR group. Set the value of each parameter according to the system requirements and recommended action shown below:

EEPR	
Parameter	Recommended Action
Enable EEPR	Set to Yes if there is an EEPR installed in the case or walk-in box.
EEPR Motor Type	Select the EEPR valve motor type for the valve installed.
Control Mode	Select the type of control desired for EEPR logic. SST/Pressure = EEPR will regulate the saturated suction temperature to the currently active SST setpoint. Discharge Air = EEPR will regulate air temperature inputs to the air temperature setpoint.
EEPR Cal. Method	Select the calibration method for the EEPR stepper valve according the valve manufacturer recommendation. Every Defrost =The valve calibration will be performed during each defrost cycle. First Defrost Only =The valve calibration will only be performed during the first scheduled defrost of the day.
Refrigerant Curve	Select the PT conversion method for the EEPR control when Control Mode is SST/Pressure. The options are dew, 60/40 Avg, Mid and bubble point. Midpoint or 60/40 Avg is recommended for EEPR control of SST. 60/40 Avg. is a weighted average of 60% dew point and 40% bubble point.
Low Temp. SST Setpoint	Enter the case or walk-in low temperature saturated suction temperature setpoint from the manufacturer recommendation. The low temp setpoint will be used when Case Temp Mode is Low or when dual temperature is in low temp mode.
Med Temp. SST Setpoint	Enter the case or walk-in medium temperature saturated suction temperature setpoint from the manufacturer recommendation. The medium temp setpoint will be used when Case Temp Mode is medium or when dual temperature is in medium temp mode.
Float Band	When Control Mode is SST/Pressure the floating SST algorithm can be enabled. A value of 0 disables floating SST, a value of 4-6 is suggested for floating SST. See Section 4.8, Fan Control of this manual for an overview of the floating SST algorithm.
Max Steps	Enter the maximum steps for the EEPR valve from the valve OEM recommendation.
Step Rate	Enter the step rate for the EEPR valve from the valve OEM recommendation.
Over Close	Enter the overclose % that the valve should be over driven during calibration.
Relax Steps	The amount of steps to open the valve after calibration. Generally 4 steps or more are needed to relax valve seat tension. Entering a number of steps too large could result in refrigerant flow with valve at 0%.

EEPR	
Parameter	Recommended Action
Minimum Opening	The minimum amount of opening for the EEPR valve during refrigeration.
Proportional	The proportional band for EEPR PID regulation. The proportional band is applied above the setpoint, P output will be 100% at the top of setpoint plus P band. A starting value of 25 for EEPR regulation is recommended.
P Band Offset	Enter the proportional band offset. For most applications this parameter can remain 0.
Integral	The Integral term for EEPR PID regulation. A large I value means less output from the I term, a smaller I value means more output from the I term. A starting value of 180 for EEPR regulation is recommended.
Derivative	The derivative term for EEPR PID regulation. For most applications the D can remain 0.
Derivative Time	The derivative time value for EEPR PID regulation. For most applications the derivative time can remain 0.

EEV	
Parameter	Recommended Action
EEV Cal Method	Select the calibration method for the EEV stepper valves according the valve manufacturer recommendation. Every Defrost =The valve calibration will be performed during each defrost cycle. First Defrost Only =The valve calibration will only be performed during the first scheduled defrost of the day. The factory default of First Defrost Only can be left when Sporlan SER EEV's are used.
EEV 1 Motor Type	Select valve motor type for the valve installed: Unipolar Bipolar
EEV 2 Motor Type	Select valve motor type for the valve installed: Unipolar Bipolar
EEV 3 Motor Type	Select valve motor type for the valve installed: Unipolar Bipolar
Start Position	The percentage position of the valve at each regulation cycle start (post defrost and on initial controller power up). The valve will be at this position for the time defined in Start Hold Time .
Start Hold Time	The amount of time the valve will remain at the Start Position. Once the time expires the valve will return to normal regulation control.
Max Steps	Maximum steps for the stroke of the valve. Enter the maximum steps from the valve OEM data sheet.
Step Rate	Step rate (steps/second) to move the valve. Enter the step rate from the valve OEM data sheet.
Overclose	The percentage of the max steps to over close the valve during calibration. The default value of 10% is sufficient.
Relax Steps	Steps to open the valve immediately after calibration to release torque on the valve needle. Generally, 4 steps or more are needed to relax valve seat tension. Entering a number of steps too large could result in refrigerant flow with valve at 0%.
Min Opening	Minimum allowed opening percentage during superheat regulation. A value of 0 is recommended for properly sized valves.

8. Once EEPR parameters are set and saved, tap on the Lights group. Set the value of each parameter according to the system requirements and recommended action shown below:

Lights	
Parameter	Recommended Action
Control Mode	Select the lighting control mode: DI Triggers: The lights turn on when the motion input is true or the door input is true. The lights remain on for the duration defined by ON DURATION. Schedule w/Dimming: The lights will turn on/off during the local schedule times. When the lights are scheduled on light dimming will be applied when motion is detected by the motion input. Supervisor w/Dimming: The lights will turn on/off according to the Supervisor Controller command. When the lights are scheduled on, light dimming will be applied when motion is detected by the motion input. Local Schedule Only: The lights will turn on/off based on the local schedule time only. No dimming. Supervisor Control: The lights will turn on/off based on the supervisor command only.
Door Lights On	When a door switch digital input is configured door opening can cause lights to turn on. Set DOOR LIGHTS ON to ON for door openings to cause lights to turn on.
Motion Lights On	When a motion switch digital input is configured and the lights control mode is set to DI TRIGGERS or a dimming mode the motion switch can cause lights to turn on. Set MOTION LIGHTS ON to ON for door openings to cause lights to turn on.
On Duration	If lights turn on due to door switch or motion switch, they will remain on for this duration after a rising edge of the switch.
Maximum Dim	When the Motion input changes to an active state, the Dimming output will change from its minimum value to the maximum value proportionally over a three second period. If the Motion input is inactive for five minutes, the Dimming output will change from its maximum value to the minimum value proportionally over a five second period.
Minimum Dim	When the Motion input changes to an active state, the Dimming output will change from its minimum value to the maximum value proportionally over a three second period. If the Motion input is inactive for five minutes, the Dimming output will change from its maximum value to the minimum value proportionally over a five second period.
Lights On Time	Enter the on time HH:MM for the lights to turn on. The off time can also be set before the on time if the schedule needs to continue into the following day, or an off schedule is preferred.
Lights Off Time	Enter the off time HH:MM for the lights to turn on. The off time can also be set before the on time if the schedule needs to continue into the following day, or an off schedule is preferred.

9. Once Lights parameters are set and saved, tap on the Alarms group. Set the value of each parameter according to the system requirements and recommended action shown below:

Alarms	
Parameter	Recommended Action
Temp. Alarm Hi	This is the high temperature alarm setpoint for the case. If the air temperature rises above this setpoint for longer than the delay, an alarm is generated.
Temp. Alarm Low	This is the low temperature alarm setpoint for the case. If the air temperature falls below this setpoint for longer than the delay, an alarm is generated.
Temp. Alarm Delay	The delay before generating a case air temperature alarm.
Temp. Delay After Def.	The case temperature alarming is delayed after defrost for the duration entered here.
Low SH. Alarm	The alarm setpoint for a low superheat condition. When superheat drops below Low SH Alarm for the Low SH Alarm Delay, a low superheat alarm will result.
Low Sh. Alarm Delay	Enter the duration for the low superheat alarm delay.
Fan Proof On	The amperage level required to consider the fan motor running.
Fan Proof Off	The amperage level required to consider the fan motor off.
Fan Proof Delay	When the fan feedback status does not match the fan command value for FAN PROOF DELAY, a command failure alarm will result.
Defr Proof On	When defrost heater amperage rises above the DEFR PROOF ON level the defrost heater shall be considered ON.

Alarms

Parameter	Recommended Action
Defr Proof Off	When defrost heater amperage falls below the DEFR PROOF OFF level the defrost heater shall be considered OFF.
Defr Proof Delay	Delay time before defrost heater command failure alarm. If the defrost proof status and the commanded value for the defrost heater do not match, a defrost command failure alarm will result.
Door Alarm Delay	When a door switch digital input is configured, a door alarm will occur when the door is left open for the duration specified here.

10. Once Lights Alarms are set and saved, tap on the AI Config group. Set the value of each parameter according to the system requirements and recommended action shown below:

AI Config

Parameter	Recommended Action
DAT Config	Select the discharge air configuration. For walk-in boxes, set the value to Not Used and use RAT Config to configure the air sensor. Not Used = No discharge air sensors are used for control 1 Per Coil = Discharge air sensors are installed on each evaporator coil
RAT Config	Select the return air configuration. For walk in boxes, set the value to 1 Per Coil and set DAT Config to Not Used . If return air sensors are installed in cases, set the value to 1 Per Coil here. Not Used = No return air sensors are used for control 1 Per Coil = return air sensors are installed on each evaporator coil
Pressure Config	Select the pressure transducer configuration to match the installation of the case or walk-in box. 1 Per Coil = There is one pressure transducer installed for each evaporator coil 1 Per Case = There is one pressure transducer installed for the entire case. For 1 Per Case configurations with multiple coils, CC200 will use the single transducer value to calculate superheat for all coils.
Pressure 1 Scale	Select the high end engineering unit scale for pressure transducer 1 that matches the transducer specification. Options of 100, 150, 200 and 300 PSI are available. Only 5VDC .5-4.5 VDC signal transducers can be used.
Pressure 2 Scale	Select the high end engineering unit scale for pressure transducer 2 that matches the transducer specification. Options of 100, 150, 200 and 300 PSI are available. Only 5VDC .5-4.5 VDC signal transducers can be used.
Pressure 3 Scale	Select the high end engineering unit scale for pressure transducer 3 that matches the transducer specification. Options of 100, 150, 200 and 300 PSI are available. Only 5VDC .5-4.5 VDC signal transducers can be used.
Defr CT Enable	Select if the DEFR CT Amps input on the CC200 will be used for heater amperage monitoring.
Defr CT Scale	Select the high end amperage scale of the defrost CT (current transducer). Only 4-20mA signal CT's are supported.
Aux AI 1 Funct	Select an auxiliary AI function if there is a sensor installed.
Aux AI 2 Funct	Select an auxiliary AI function if there is a sensor installed.
Fan CT Scale	Select the fan current transducers high end amperage value if an aux AI is set to Fan CT. Only 4-20mA signal CT's are supported.
Offsets	An offset parameter is provided for each sensor for service purposes. For most situations no offset is required. Enter an offset if needed to calibrate the sensor.

11. Once AI Config parameters are set and saved, tap on the RO Config group. Set the value of each parameter according to the system requirements and recommended action shown below:

RO Config	
Parameter	Recommended Action
Aux RO Function	Select a function for the relay labeled AUX RELAY on CC200 enclosure. The aux RO can be used as a backup for the other 4 fixed relay functions or for additional CC200 features. The options are: Not Used Light Fan LLSV REFRIG RO Defrost Alarm = General alarm output if any alarm is active Door alarm = Door alarm output for walk in box door left open Satellite 1 = Satellite RO for direct E2E control
Active State	Each relay has an active state set if the relay should be energized or de-energized to turn on its controlled load.

12. Once RO Config parameters are set and saved, tap on the DI Config group. Set the value of each parameter according to the system requirements and recommended action shown below:

DI Config	
Parameter	Recommended Action
CC200 DI 1 Func. CC200 DI 2 Func. CC200 DI 3 Func. CC200 DI 4 Func. Exp Mod 1 DI Func. Exp Mod 2 DI Func. Exp Mod 3 DI Func.	Each CC200 and Expansion Module digital input has a selectable function: Not Used = No digital input wired or used Door = Door switch connected Service Shutdown = Service shutdown switch or button connected Dual Temp. = Dual temperature switch connected Defrost Term. = Defrost termination switch or input connected Motion = Motion sensor for case lighting control connected Leak Shutdown = Refrigerant leak shutdown input connected Satellite 1 = Satellite digital input for E2E, DI value is passed to E2E for use in Supervisor Controller Satellite 2 = Satellite digital input for E2E, DI value is passed to E2E for use in Supervisor Controller
Active State	Each digital input function has an associated active state parameter to determine what state of the input should result in an ON value in CC200 logic. See Section 4.4, Dual Temperature Cases of this manual for active state for digital inputs.

13. Once DI Config parameters are set and saved, tap on the AO Config group. Set the value of each parameter according to the system requirements and recommended action shown below:

AO Config	
Parameter	Recommended Action
AO 1 Function/AO2 Function	Select a function for CC200 AO1 if used: Not Used =No AO used or wired up Dimming =Light dimming AO signal Satellite 1 =Satellite AO for direct E2E control, E2E will control via network Satellite 2 = Satellite AO for direct E2E control, E2E will control via network
Dimming AO Sig	Select the signal type for the analog output function: 0-10VDC 4-20mA
Sat. 1 AO Sig	Select the signal type for the analog output function: 0-10VDC 4-20mA
Sat. 2 AO Sig	Select the signal type for the analog output function: 0-10VDC 4-20mA
Dim AO Invert	Select if the signal output should be inverted. Inverting the signal output will cause the AO to deliver max signal at 0% and min signal at 100%
Sat. 1 AO Invert	Select if the signal output should be inverted. Inverting the signal output will cause the AO to deliver max signal at 0% and min signal at 100%
Sat. 2 AO Invert	Select if the signal output should be inverted. Inverting the signal output will cause the AO to deliver max signal at 0% and min signal at 100%

14. Once DI Config parameters are set and saved, tap on the AO Config group. Set the value of each parameter according to the system requirements and recommended action shown below:

BACnet Protocol	
Parameter	Recommended Action
MS/TP MAC	Enter a unique address number for the CC200 designated as the router. All non-router devices can leave this at the default value.
MS/TP Baud	Enter the baud rate used for the router device to communicate with E2E/Supervisory Controllers. All non router devices can leave this at the default value.
Rack ID	Enter the rack ID. This sets the refrigeration rack system ID which is used for calculating BACnet device ID. This must be set for every CC200 on the communication bus.
Circuit ID	Enter the circuit ID. This sets the refrigeration circuit ID which is used for calculating BACnet device ID. This must be set for every CC200 on the communication bus
Case ID	Enter the case letter. This sets the case letter ID that is used for calculating BACnet device ID. This must be set for every CC200 on the communication bus.
Max Master	Enter the max master for BACnet MS/TP. This must be set to the highest address between the supervisor and the router CC200.
APDU Retries	Leave factory default.
APDU Timeout	Leave factory default.
Max Info Frames	Leave factory default.
Router Enable	This must be set to yes for the CC200 designated as the router device. Only a single CC200 per communication bus needs to be set as the router device, all others should set this parameter to No. See Section 6, The BACnet Network of this manual for a detailed overview of the BACnet network and BACnet router.

11. Technical Specifications and Part Numbers

11.1 CC200 Case Controller Specifications

Name	Description
Power Requirements	24VDC 71(Earth) - 72(+) - 73(-)
Power Supply	SELV/ Class 2 Source, 24VDC
Rated Impulse Voltage	0.5 kV (Main supply side) / 2.5kV (Loads side)
Ambient Operating Temperature	14°F to 122°F (-10°C to 50°C)
Storage Temperature	-40°F to 185°F (-40°C to 85°C)
Relative Humidity	20 to 85% 20 to 85% RH; non-condensing
Mounting	DIN Rail
Dimensions Enclosure	7 3/16" x 4 5/16" x 3" (W x H x D) Type 1
RS485 Port A RS485 Port B	Less than 1/6 unit loading, up to 115.2K Baud, isolated; generic 150-ohm termination with switch. 3-Terminal connector with onboard 100-ohm between RS485 "C" Terminal and RS485 isolated ground to allow direct earth ground connection. The RS485 Port A and B grounds are isolated from each other and all other circuit and earth grounds.
ETH1 ETH2	BACnet TCP/IP repeater (Ethernet 10/100) BACnet TCP/IP repeater (Ethernet 10/100)
Purpose of Control	Operating Control
Construction of Control	Din rail mounting control to be incorporated in Class I or Class II appliances
Pollution Degree	2
Type of Action	1.B
Over-voltage Category	II

11.2 CC200 Power Supply Specifications

Name	Description
Primary Power	120VAC
Secondary Power	24VDC
CC200 Power Requirements*	24VDC 60W
Required Power Supply*	CC200 Power Supply Copeland P/N 318-3183
Power Supply Terminals	2 (-V) & 3 (+V)
CC200 Power Terminals	72(+) --73(-) -- 71(Earth)
Wire Spec	16AWG or larger diameter wire
Max Wire Length	20"
Mounting	DIN Rail Mounted
Power Supply Dimensions*	2.06" x 3.54" x 2.14" (W x H x D)

*Note: If the CC200 system has three (3) expansion modules, the 92W P/N 318-3184 power supply is required.

11.3 CC200 Case Expansion Module Specifications

Name	Description
Operating Temperature	14°F to 122°F (-10°C to 50°C)
Relative Humidity	20-85% RH; non-condensing
Enclosure	Type: 4 DIN Rail Mountable Rating: UL 94V-0
Dimensions	110mm x 183mm (4 5/16" x 7 3/16")

11.4 CC200 Case Display Specifications

Name	Description
Power Requirement	Powered from the CC200 Case Controller
Rated Impulse Voltage	330V
Power Supply	Class 2, SELV 12VAC, less than 15W
Purpose of control	Operating Control
Construction of control	Panel mounting control to be incorporated in Class III appliances
Type of Action	1.B
Enclosure	Type 1
Over-voltage Category	I
Required Wire	Belden #8871 3C 22AWG or Belden #8772 3C20AWG, Max 50 ft.
Physical Dimensions	Refer to CC200 Case Display Dimensions diagram .
Mounting Dimensions	Refer to CC200 Case Display Dimensions diagram .
Mounting	Use the white sliding clips that are provided with the CC200 Display
Ambient Operating Temperature	14°F to 122°F / -10°C to 50°C
Storage Temperature	-40°F to 185°F / -40°C to 85°C
Relative Humidity	20 to 85 RH% (non-condensing humidity)
Protection	Body: IP20; Front: IP65
Pollution Degree	2

Points	CC200 Terminals to CC200 Display Terminals
-	27(-) to 5(-)
+	28(+) to 4(+)
VNR	29(VNR) to 3(VNR)

11.5 Part Numbers for Ordering

*Copeland Part Number	Description
810-3180	CC200 Main Controller
318-3181	CC200 Expansion Module
318-3182	CC200 Case Display
318-3183	CC200 Power Supply, 24VDC, 2.5A, 60W, DIN Mount
318-3184	CC200 Power Supply, 24VDC, 3.83A, 92W, DIN Mount Note: If the CC200 system has three (3) expansion modules, the 92W P/N 318-3184 power supply is required.
501-1122	Discharge Air Temperature Sensor
501-1127	Defrost Termination Temperature Sensor
501-1128	Return Air Temperature Sensor
501-1125 (blue) 501-1126 (red)	Coil Out Temperature Sensor
800-2100	100lb Pressure Transducer
800-2650	Copeland 650 PSIG Pressure Transducer
118-4101	Door Switch Walk-In Box
261-0001	CC200 Defrost/Fan CT, 20A (4-20mA)
261-0002	CC200 Walk In Defrost CT, 50A (4-20mA)
302-0100	CC200 Case Display Bracket Note: For use with 318-3182 CC200 Case Display
302-0105	Deli Case Display Bracket

*For optimal performance of the CC200, Copeland parts are required.

Appendix A: CC200 Parameters

PARAMETER NAME	DESCRIPTION	UNIT	MIN	MAX	GROUP	LIST OPTION
MS/TP MAC	Enter the BACnet MS/TP MAC Address of the controller	None	0	127	BACnet	
MS/TP Baud	Select the MS/TP baud rate for BACnet	List	1	5	BACnet	9600 19200 38400 57600 115200
IP Octet 1	Set the value of IP address octet 1	None	0	254	BACnet	*Note: IP Octet 1 parameter only available in 1.03F01 firmware and later.
Rack ID	Select the rack system ID for the case or lineup	List	1	58	BACnet	A, B, C, D, E, F, G, H, AS, BS, CS, DS, MT, MTA, MTB, MTC, MT1, MT2, MT3, MT4, MT5, LT, LTA, LTB, LTC, LT1, LT2, LT3, LT4, LT5, DT, DTA, DTB, DTC, DT1, DT2, DT3, RCU, SC, MS1, MS2, MS3, MS4
Circuit ID	Select the circuit number for this lineup	None	1	99	BACnet	
Case ID	Select the case letter for this case	List	1	8	BACnet	
Max Master	Enter the BACnet max master of the controller	None	0	127	BACnet	
APDU Retries	Enter number of application protocol data unit retries	None	1	9	BACnet	
APDU Timeout	Enter application protocol data unit timeout	Seconds	2	120	BACnet	

Appendix A: CC200 Parameters

PARAMETER NAME	DESCRIPTION	UNIT	MIN	MAX	GROUP	LIST OPTION
Max Info Frames	Enter max frames to send per token	None	1	50	BACnet	
Router Enable	Enable BACnet MS/TP to IP router	List	0	1	BACnet	No, Yes
Address	Modbus address of this device	None	1	254	Modbus	
Baud Rate	Modbus baud rate of this device	None	0	4	Modbus	9600 19200 38400 57600 115200
IP Octet 1	Set the value of IP address octet 1	None	0	254	BACnet	*Note: IP Octet 1 parameter only available in 1.03F01 firmware and later.
Rack ID	Select the rack system ID for the base or lineup	List	1	58	Modbus	A, B, C, D, E, F, G, H, AS, BS, CS, DS, MT, MTA, MTB, MTC, MT1, MT2, MT3, MT4, MT5, LT, LTA, LTB, LTC, LT1, LT2, LT3, LT4, LT5, DT, DTA, DTB, DTC, DT1, DT2, DT3, RCU, SC, MS1, MS2, MS3, MS4
Circuit ID	Select the circuit number	None	1	99		
Case ID	Select the case letter	List	1	8		a, b, c, d, e, f, g, h
Data Bits	Modbus message number of data bits	None	7	8		
Parity	Modbus message parity type	None	0	2		even, odd, none

Appendix A: CC200 Parameters

PARAMETER NAME	DESCRIPTION	UNIT	MIN	MAX	GROUP	LIST OPTION
Stop Bits	Modbus message number of stop bits		1	2		
Refrigerant	Selects the refrigerant gas type of the system	List	1	13	Sys.Setup	R-407A R-404A R-22 R-410A R-422D R-134a R-407C R-422A R-427A R-507A R-438A R-422C R-448A R-744 R-454C R-455A R-457A R-471A R-1234yf R-1234ze
Expansion Valve Type	Select the expansion valve type installed	List	1	4	Sys. Setup	TEV TEV SH Monitor EEV PWM
*Compression Type	Select the system compression type. *Note: Compression Type parameter is available in version CC200 1.01F01 and later.	List	1	4	Sys. Setup	RCU-Fixed Cap - Remote condensing unit with a fixed capacity compressor. RCU-Variable Cap - Remote condensing unit with variable speed motor or variable capacity through unloader modulation. Rack-Fixed Cap - Parallel rack system with no digital unloader or variable speed motor. Rack-Variable Cap - Parallel rack system with at least one compressor able to vary capacity by motor speed or variable unloader.

Appendix A: CC200 Parameters

PARAMETER NAME	DESCRIPTION	UNIT	MIN	MAX	GROUP	LIST OPTION
*EPR Type	Select the type of EPR valve installed. *Note: EPR Type parameter is available in version CC200 1.01F01 and later.	List	1	3	Sys. Setup	Not Used - There is no evaporator pressure regulator valve installed for this system. Electric (EEPR) - There is an electric stepper motor valve used for suction regulation on this system. Mechanical (EPR) - There is a mechanical evaporator pressure regulator in use for this system.
Cases In Lineup	Specifies the number of cases in the refrigeration lineup	None	1	8	Sys. Setup	
Case Temp. Mode	Select if the system is low, medium, or dual temperature	List	1	3	Sys. Setup	Low Temp Med Temp Dual Temp
Number of Coils	Select the number of evaporator coils controlled by CC200	None	1	3	Sys. Setup	
*Continuous Refrigeration	Specifies if LLSV should cut in/cut out with setpoint and deadband. *Note: The Continuous Refrigeration parameter was deprecated in CC200 1.01F01 and is only available in CC200 versions prior to 1.00F01	List	0	1	Sys. Setup	No, Yes
LLSV Present	Select if a liquid line solenoid is wired to REFRIG relay output	List	0	1	Sys. Setup	No, Yes
Control Sensor	Select the type of air sensor used for temperature control	List	1	2	Sys. Setup	Discharge Air Return Air
Case Temp. Combination	Select the sensor combination method (avg, min, max)	List	1	3	Sys. Setup	Average Minimum Maximum

Appendix A: CC200 Parameters

PARAMETER NAME	DESCRIPTION	UNIT	MIN	MAX	GROUP	LIST OPTION
PWM Valve Period	Enter the period for the PWM valve	Seconds	1	12		
PWM Short Cycle	This is the PWM Valve minimum control % and prevents short cycle of valve by limiting the minimum ON time of Valve during the Pulse Period.	Percent	0	100		
Low Temp. Air Setpoint	Air temperature setpoint - low temp mode	DF	-99	99	Setpoints	
Medium Temp. Air Setpoint	Air temperature setpoint - med temp mode	DF	-99	99	Setpoints	
Air Setpoint Deadband	Refrigeration setpoint band (+/- half)	DDF	2	20	Setpoints	
Superheat Setpoint	Superheat control setpoint that all evaporators will be controlled to	DDF	2	20	Setpoints	
Superheat Deadband	Deadband around sh setpoint (+/- half)	DDF	0	20	Setpoints	
Superheat Optimize Setpoint	Setpoint during superheat optimization mode	DDF	0	20	Setpoints	* Note: Superheat Optimize Setpoint parameter is available in version CC200 1.02F02 and later.
Superheat Optimize Ramp	Ramp time between setpoints when entering or exiting superheat optimization mode	Seconds	0	3600	Setpoints	* Note: Superheat Optimize Ramp parameter is available in version CC200 1.02F02 and later.
Max Pulldown Time	The maximum time allowed in pulldown	Minutes	0	120	Setpoints	
Door Disables Refrig.	Door opening disables refrigeration	List	0	1	Setpoints	No, Yes

Appendix A: CC200 Parameters

PARAMETER NAME	DESCRIPTION	UNIT	MIN	MAX	GROUP	LIST OPTION
Door Failsafe Timeout	Reactivate refrig. timeout when door is open	Minutes	0	120	Setpoints	
Heat Type	Defrost heat type: Electric, Off Cycle	List	1	2	Defrost	Electric Off Cycle
Defrost Start Time	Start time hour for first defrost of the day	None	0	23	Defrost	
	Start time minute for first defrost of the day	None	0	59	Defrost	
Cycles Per Day	The number of defrosts per day spaced evenly in 24 hours	None	1	12	Defrost	
Termination Type	Select the method of defrost termination: time, temperature, digital input	List	1	3	Defrost	Time Temp DI
Termination Sensor	Select the sensor to use for defrost termination	List	1	3	Defrost	Defrost Term Discharge Air Coil Out
Term. Combination	Defrost termination sensor combination method	List	1	3	Defrost	Average Minimum Maximum
Term. Temp. Setpoint	Defrost termination temperature setpoint	DF	0	99	Defrost	
Minimum Time	The minimum time defrost must run before termination is allowed	Minutes	0	60	Defrost	
Maximum Time	Defrost maximum allowed run time	Minutes	5	120	Defrost	

Appendix A: CC200 Parameters

PARAMETER NAME	DESCRIPTION	UNIT	MIN	MAX	GROUP	LIST OPTION
Drip Time	Defrost evaporator drip time	Minutes	0	30	Defrost	
Pump Down Time	Pump down delay to remove liquid from evaporator	Minutes	0	20	Defrost	
Demand Defrost Enable	Enables demand defrost	None	0	1	Defrost	*Note: Demand Defrost Enable parameter is available in version CC200 1.02F02 and later.
Max Time Without Demand Defrost	Maximum time without a defrost before demand defrost must trigger					*Note: Max Time Without Demand Defrost parameter is available in version CC200 1.02F02 and later.
Fan In Refrig.	Select the fan behavior during refrigeration cycle	List	1	2	Fan	Continuous On Cut In/Cut Out
Fan In Defrost	Select the fan behavior during defrost cycle	List	1	2	Fan	On In Defrost Off In Defrost
Delay Method	Method to delay fan after defrost	List	1	2	Fan	Time Delay Coil Temp
Delay Time	Time delay to reactivate fan	Seconds	0	600	Fan	
Delay Temp.	Coil out temp setpoint to reactivate fan	DF	-99	99	Fan	
ECM Present	Select if ECM fan motor is in use	List	0	1	Fan	No, Yes
*Enable EEPR	Enable/disable EEPR control. *Note: Enable EEPR parameter has been deprecated in CC200 1.01F01 and superseded by EPR Type, use EPR Type to enable/disable EEPR usage.	List	0	1	EEPR	Disabled, Enabled

Appendix A: CC200 Parameters

PARAMETER NAME	DESCRIPTION	UNIT	MIN	MAX	GROUP	LIST OPTION
EEPR Motor Type	Stepper motor type: Unipolar, Bipolar	List	1	2	EEPR	Unipolar Bipolar
Control Mode	EEPR control mode: Discharge air, SST	List	1	2	EEPR	SST/Pressure Discharge Air
EEPR Cal. Method	EEPR valve calibration method	List	1	2	EEPR	Every Defrost First Defrost Only
Refrigerant Curve	Refrigerant curve type for SST control	List	1	4	EEPR	Dew Point 60/40 Avg Mid Point Bubble Point
Low Temp. SST Setpoint	Sat. suction temp. set in low temp mode	DF	-40	40	EEPR	
Med Temp. SST Setpoint	Sat. suction temp. set in med temp mode	DF	-40	40	EEPR	
Float Band	Band to float SST in, 0 disables float (only used in SST mode)	DDF	0	40	EEPR	
Max Steps	Maximum steps for EEPR stepper valve	None	0	10000	EEPR	
Step Rate	EEPR valve step rate (steps/second)	None	0	400	EEPR	
Over Close	Percentage of maximum steps to over drive during calibration	Percent	0	100	EEPR	
Relax Steps	Reverse steps after overclose EEPR	None	0	100	EEPR	

Appendix A: CC200 Parameters

PARAMETER NAME	DESCRIPTION	UNIT	MIN	MAX	GROUP	LIST OPTION
Minimum Opening	Reverse steps after overclose EEPR	Percent	0	100	EEPR	
Proportional	Proportional band for EEPR PID	DDF	2	100	EEPR	
P Band Offset	Band offset for EEPR PID regulation	DDF	-50	50	EEPR	
Integral	Integral for EEPR PID regulation	None	0	255	EEPR	
Derivative	Derivative for EEPR PID regulation	None	0	500	EEPR	
Derivative Time	Derivative time for EEPR PID regulation	None	0	500	EEPR	
EEV Cal Method	Select calibration method for EEV stepper	List	1	2	EEV	Every Defrost First Defrost Only
EEV 1 Motor Type	Valve motor type (Unipolar or Bipolar)	List	1	2	EEV	Unipolar Bipolar
EEV 2 Motor Type	Valve motor type (Unipolar or Bipolar)	List	1	2	EEV	Unipolar Bipolar
EEV 3 Motor Type	Valve motor type (Unipolar or Bipolar)	List	1	2	EEV	Unipolar Bipolar
Start Position	EEV1-3 position at beginning of regulation	Percent	0	100	EEV	
Start Hold Time	Time to hold EEV1-3 in start position	Seconds	0	1800	EEV	

Appendix A: CC200 Parameters

PARAMETER NAME	DESCRIPTION	UNIT	MIN	MAX	GROUP	LIST OPTION
EEV 1 Max Steps	Maximum steps of the valve	NA	0	10000	EEV	
EEV 1 Step Rate	Valve step rate (steps/ seconds)	NA	0	400	EEV	
EEV 1 Overclose	Percentage of maximum steps to over drive during calibration	Percent	0	100	EEV	
EEV 1 Relax Steps	Steps to open after calibration procedure	NA	0	50	EEV	
EEV 1 Min Opening	Minimum opening allowed during regulation	Percent	0	100	EEV	
EEV 2 Max Steps	Maximum steps of the valve	NA	0	10000	EEV	
EEV 2 Step Rate	Valve step rate (steps/ seconds)	NA	0	400	EEV	
EEV 2 Overclose	Percentage of maximum steps to over drive during calibration	Percent	0	100	EEV	
EEV 2 Relax Steps	Steps to open after calibration procedure	NA	0	50	EEV	
EEV 2 Min Opening	Minimum opening allowed during regulation	Percent	0	100	EEV	
EEV 3 Max Steps	Maximum steps of the valve	NA	0	10000	EEV	
EEV 3 Step Rate	Valve step rate (steps/ seconds)	NA	0	400	EEV	

Appendix A: CC200 Parameters

PARAMETER NAME	DESCRIPTION	UNIT	MIN	MAX	GROUP	LIST OPTION
EEV 3 Overclose	Percentage of maximum steps to over drive during calibration	Percent	0	100	EEV	
EEV 3 Relax Steps	Steps to open after calibration procedure	NA	0	50	EEV	
EEV 3 Min Opening	Minimum opening allowed during regulation	Percent	0	100	EEV	
Superheat KP	Superheat P gain for temp EEV regulation	None	0	10	EEV	*Note: Superheat KP parameter is available in version CC200 1.01F01 and later.
Superheat KI	Superheat I gain for temp EEV regulation	None	0	10	EEV	*Note: Superheat KI parameter is available in version CC200 1.01F01 and later.
Control Temp KP	Temperature P gain for temp EEV reg.	None	0	10	EEV	*Note: Control Temp KP parameter is available in version CC200 1.02F01 and later.
Control Temp KI	Temperature I gain for temp EEV reg.	None	0	10	EEV	*Note: Control Temp KI parameter is available in version CC200 1.01F01 and later.
Control Mode	Select the lighting control strategy	List	1	5	Lights	DI Triggers Schedule w/Dim Supervisor w/Dim Local Schedule Supervisor
Door Lights On	Lights switch ON when door is open	List	0	1	Lights	No, Yes
Motion Lights On	Lights switch ON when motion is detected	List	0	1	Lights	No, Yes
On Duration	Lights on duration for door or motion DI	Minutes	0	120	Lights	

Appendix A: CC200 Parameters

PARAMETER NAME	DESCRIPTION	UNIT	MIN	MAX	GROUP	LIST OPTION
Minimum Dim	Minimum light level for dimming logic	Percent	0	100	Lights	
Maximum Dim	Maximum light level for dimming logic	Percent	0	100	Lights	
Lights On Time	Hour of the time of day to turn the lights on	None	0	23	Lights	
	Minute of the time of day to turn the lights on	None	0	59	Lights	
Lights Off Time	Hour of the time of day to turn the lights off	None	0	23	Lights	
	Minute of the time of day to turn the lights off	None	0	59	Lights	
Temp. Alarm Hi	High case temperature alarm limit	DF	-99	99	Alarms	
Temp. Alarm Low	Low case temperature alarm limit	DF	-99	99	Alarms	
Temp. Alarm Delay	Minutes of alarm delay for hi/low case air temperature	Minutes	0	300	Alarms	
Temp. Delay After Def.	Minutes to delay temperature alarming after each defrost cycle	Minutes	0	300	Alarms	
Low SH. Alarm	Alarm setpoint for superheat	DDF	0	50	Alarms	
Low Sh. Alarm Delay	Time delay before activating the low superheat alarm	Minutes	0	120	Alarms	

Appendix A: CC200 Parameters

PARAMETER NAME	DESCRIPTION	UNIT	MIN	MAX	GROUP	LIST OPTION
Fan Proof On	Amperage value the fan motor must reach to be considered on	Amperes	0	25	Alarms	
Fan Proof Off	Amperage value the fan motor must reach to be considered off	Amperes	0	25	Alarms	
Fan Proof Delay	Delay time for fan proof alarm	Minutes	0	10	Alarms	
Defr. Proof On	Amperage level where defrost heater is considered on	Amperes	0	25	Alarms	
Defr. Proof Off	Amperage level where defrost heater is considered off	Amperes	0	25	Alarms	
Defr. Proof Delay	Delay time for defrost proof alarm	Minutes	0	10	Alarms	
Door Alarm Delay	Alarm delay for door left open	Minutes	0	300	Alarms	
Dat Config	Select discharge air configuration	List	1	2	AI Config.	Not Used 1 Per Coil
Rat Config	Select return air configuration	List	1	2	AI Config.	Not Used 1 Per Coil
Pressure Config	Select pressure transducer configuration	List	1	2	AI Config.	1 Per Coil 1 Per Case

Appendix A: CC200 Parameters

PARAMETER NAME	DESCRIPTION	UNIT	MIN	MAX	GROUP	LIST OPTION
Pressure 1 Scale	Select high end EU for pressure 1	List	1	4	AI Config.	100 PSI 150 PSI 200 PSI 300 PSI *500 PSI *650 PSI *Custom *Note: 500, 650 and custom ranges are available in CC200 version 1.01F01 and higher.
Pressure 2 Scale	Select high end EU for pressure 2	List	1	4	AI Config.	100 PSI 150 PSI 200 PSI 300 PSI *500 PSI *650 PSI *Custom *Note: 500, 650 and custom ranges are available in CC200 version 1.01F01 and higher.
Pressure 3 Scale	Select high end EU for pressure 3	List	1	4	AI Config.	100 PSI 150 PSI 200 PSI 300 PSI *500 PSI *650 PSI *Custom *Note: 500, 650 and custom ranges are available in CC200 version 1.01F01 and higher.
Defr CT Enable	Select if defrost CT is used/not used	List	1	4	AI Config.	Disabled, Enabled

Appendix A: CC200 Parameters

PARAMETER NAME	DESCRIPTION	UNIT	MIN	MAX	GROUP	LIST OPTION
Pressure 1 Max EU	Max EU when custom pressure is selected	PSIG	0	500	AI Config.	*Note: Custom max is available in CC200 version 1.01F01 and higher.
Pressure 2 Max EU	Max EU when custom pressure is selected	PSIG	0	500	AI Config.	*Note: Custom max is available in CC200 version 1.01F01 and higher.
Pressure 3 Max EU	Max EU when custom pressure is selected	PSIG	0	500	AI Config.	*Note: Custom max is available in CC200 version 1.01F01 and higher.
Defr CT Scale	Enter high end eu of defrost CT	Amperes	0	99	AI Config.	
Aux AI 1 Funct	Select the function for aux. analog in 1	List	1	5	AI Config.	Not Used Fan CT Coil Inlet Temp Product Temp Circuit Suct Temp
Aux AI 2 Funct	Select the function for aux. analog in 2	List	1	5	AI Config.	Not Used Fan CT Circuit Suct Temp
Fan CT Scale	Enter high end eu of external fan CT	Amperes	0	50	AI Config.	
Defr CT Offset	Sensor offset for Defrost CT	Amperes	-5	5	AI Config.	
Fan CT Offset	Sensor offset for Fan CT	Amperes	-5	5	AI Config.	
DAT 1 Offset	Sensor offset for discharge air 1	DDF	-5	5	AI Config.	
DAT 2 Offset	Sensor offset for discharge air 2	DDF	-5	5	AI Config.	
DAT 3 Offset	Sensor offset for discharge air 3	DDF	-5	5	AI Config.	

Appendix A: CC200 Parameters

PARAMETER NAME	DESCRIPTION	UNIT	MIN	MAX	GROUP	LIST OPTION
RAT 1 Offset	Sensor offset for return air 1	DDF	-5	5	AI Config.	
RAT 2 Offset	Sensor offset for return air 2	DDF	-5	5	AI Config.	
RAT 3 Offset	Sensor offset for return air 3	DDF	-5	5	AI Config.	
Def. Term 1 Offset	Sensor offset for Defrost Term evap 1	DDF	-5	5	AI Config.	
Def. Term 2 Offset	Sensor offset for Defrost Term evap 2	DDF	-5	5	AI Config.	
Def. Term 3 Offset	Sensor offset for Defrost Term evap 3	DDF	-5	5	AI Config.	
Coil Out 1 Offset	Sensor offset for coil out 1	DDF	-5	5	AI Config.	
Coil Out 2 Offset	Sensor offset for coil out 2	DDF	-5	5	AI Config.	
Coil Out 3 Offset	Sensor offset for coil out 3	DDF	-5	5	AI Config.	
Pressure 1 Offset	Offset for pressure transducer evap 1	PSIG	-5	5	AI Config.	
Pressure 2 Offset	Offset for pressure transducer evap 2	PSIG	-5	5	AI Config.	
Pressure 3 Offset	Offset for pressure transducer evap 3	PSIG	-5	5	AI Config.	

Appendix A: CC200 Parameters

PARAMETER NAME	DESCRIPTION	UNIT	MIN	MAX	GROUP	LIST OPTION
Liquid Temp. Off	Offset for liquid temperature	DDF	-5	5	AI Config.	
Coil Inlet Offset	Sensor offset for coil inlet temp	DDF	-5	5	AI Config.	
Product Offset	Sensor offset for product temperature	DDF	-5	5	AI Config.	
Circ Suc. Offset	Sensor offset for circuit suction temp	DDF	-5	5	AI Config.	
Aux RO Function	Select a function for auxiliary relay	List	1	8	RO Config	Not Used Light Fan LLSV Defrost Alarm Door alarm Satellite 1
Fan RO Act	Select a state for the relay coil during logical true	List	0	1	RO Config	De-energize, Energize
Defrost RO Act	Select a state for the relay coil during logical true	List	0	1	RO Config	De-energize, Energize
Light RO Act	Select a state for the relay coil during logical true	List	0	1	RO Config	De-energize, Energize
Refrig RO Act	Select a state for the relay coil during logical true	List	0	1	RO Config	De-energize, Energize
Alarm RO Act	Select the active state for alarm RO	List	0	1	RO Config	De-energize, Energize
Door Alm. RO Act	Select the active state for door alarm RO	List	0	1	RO Config	De-energize, Energize

Appendix A: CC200 Parameters

PARAMETER NAME	DESCRIPTION	UNIT	MIN	MAX	GROUP	LIST OPTION
Sat. 1 RO Act	Select the active state for sat. 1 RO	List	0	1	RO Config	De-energize, Energize
CC200 DI 1 Func.	Select digital input function-CC200 DI1	List	1	10	DI Config.	Not Used Door Service Dual Temp. Defrost Term. Motion Leak Shutdown Satellite 1 Satellite 2
CC200 DI 2 Func.	Select digital input function-CC200 DI2	List	1	10	DI Config.	Not Used Door Service Dual Temp. Defrost Term. Motion Leak Shutdown Satellite 1 Satellite 2
CC200 DI 3 Func.	Select digital input function-CC200 DI3	List	1	10	DI Config.	Not Used Door Service Dual Temp. Defrost Term. Motion Leak Shutdown Satellite 1 Satellite 2
CC200 DI 4 Func.	Select digital input function-CC200 DI4	List	1	10	DI Config.	Not Used Door Service Dual Temp. Defrost Term. Motion Leak Shutdown Satellite 1 Satellite 2
Exp Mod 1 DI Func.	Expansion module 1 DI 1 function	List	1	10	DI Config.	Not Used Door Service Dual Temp. Defrost Term. Motion Leak Shutdown Satellite 1 Satellite 2

Appendix A: CC200 Parameters

PARAMETER NAME	DESCRIPTION	UNIT	MIN	MAX	GROUP	LIST OPTION
Exp Mod 2 DI Func.	Expansion module 2 DI 1 function	List	1	10	DI Config.	Not Used Door Service Dual Temp. Defrost Term. Motion Leak Shutdown Satellite 1 Satellite 2
Exp Mod 3 DI Func.	Expansion module 3 DI 1 function	List	1	10	DI Config.	Not Used Door Service Dual Temp. Defrost Term. Motion Leak Shutdown Satellite 1 Satellite 2
Door DI Act	Select active state of door switch DI	List	0	1	DI Config.	Off, On
Service DI Act	Select active state of service switch DI	List	0	1	DI Config.	Off, On
Dual Temp DI Act	Select active state of dual temp DI	List	0	1	DI Config.	Off, On
Def. Term DI Act	Select active state of defrost term DI	List	0	1	DI Config.	Off, On
Motion DI Act	Select active state of motion switch DI	List	0	1	DI Config.	Off, On
Sat 1 DI Act	Select active state of satellite 1 DI	List	0	1	DI Config.	Off, On
Sat 2 DI Act	Select active state of satellite 2 DI	List	0	1	DI Config.	Off, On

Appendix A: CC200 Parameters

PARAMETER NAME	DESCRIPTION	UNIT	MIN	MAX	GROUP	LIST OPTION	
Leak DI Act	Select active state of leak shutdown DI	List	0	1	DI Config.	Off, On	
AO 1 Function	Select the function for analog out 1	List	1	4	AO Config.	Not Used Dimming	Satellite 1 Satellite 2
AO 2 Function	Select the function for analog out 2	List	1	4	AO Config	Not Used Dimming	Satellite 1 Satellite 2
Dimming AO Sig	AO configuration (0..10V,4..20mA)	List	1	2	AO Config	0-10VDC 4-20mA	
Sat. 1 AO Sig	AO configuration (0..10V,4..20mA)	List	1	2	AO Config	0-10VDC 4-20mAs	
Sat. 2 AO Sig	AO configuration (0..10V,4..20mA)	List	1	2	AO Config	0-10VDC 0mA	
Dim AO Invert	Invert dimming analog output signal	List	0	1	AO Config	No, Yes	
Sat. 1 AO Invert	Invert sat 1 analog output signal	List	0	1	AO Config	No, Yes	
Sat. 2 AO Invert	Invert sat 2 analog output signal	List	0	1	AO Config	No, Yes	

Appendix B: Dimensions

The CC200, Expansion Module, and power supply are DIN rail mounted components. The CC200 display is mounted in a cut-out hole in a vertical panel and secured using the supplied mounting brackets. The dimensions of each component are shown below.

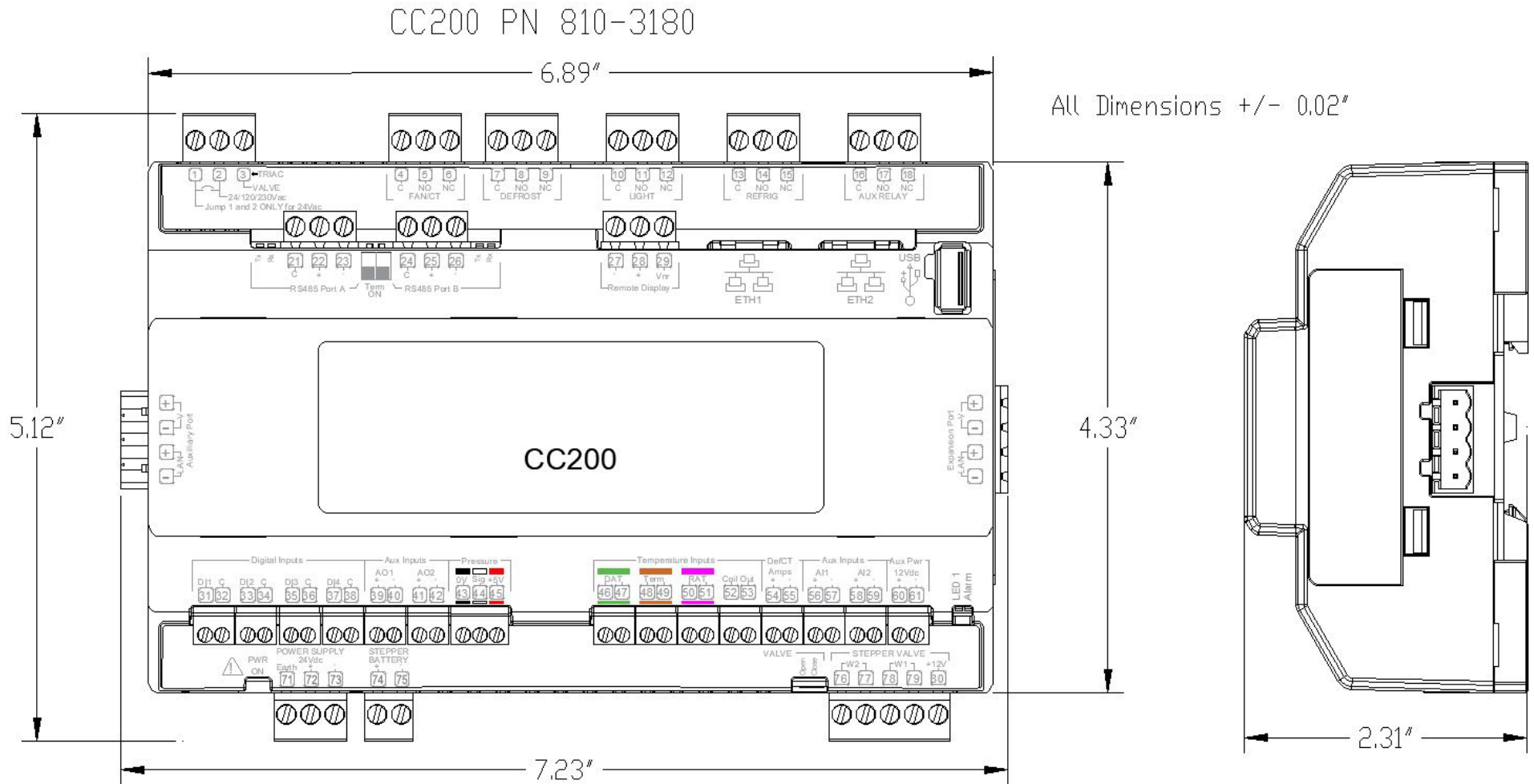

Appendix B: Dimensions

CC200 Expansion Module PN 318-3181

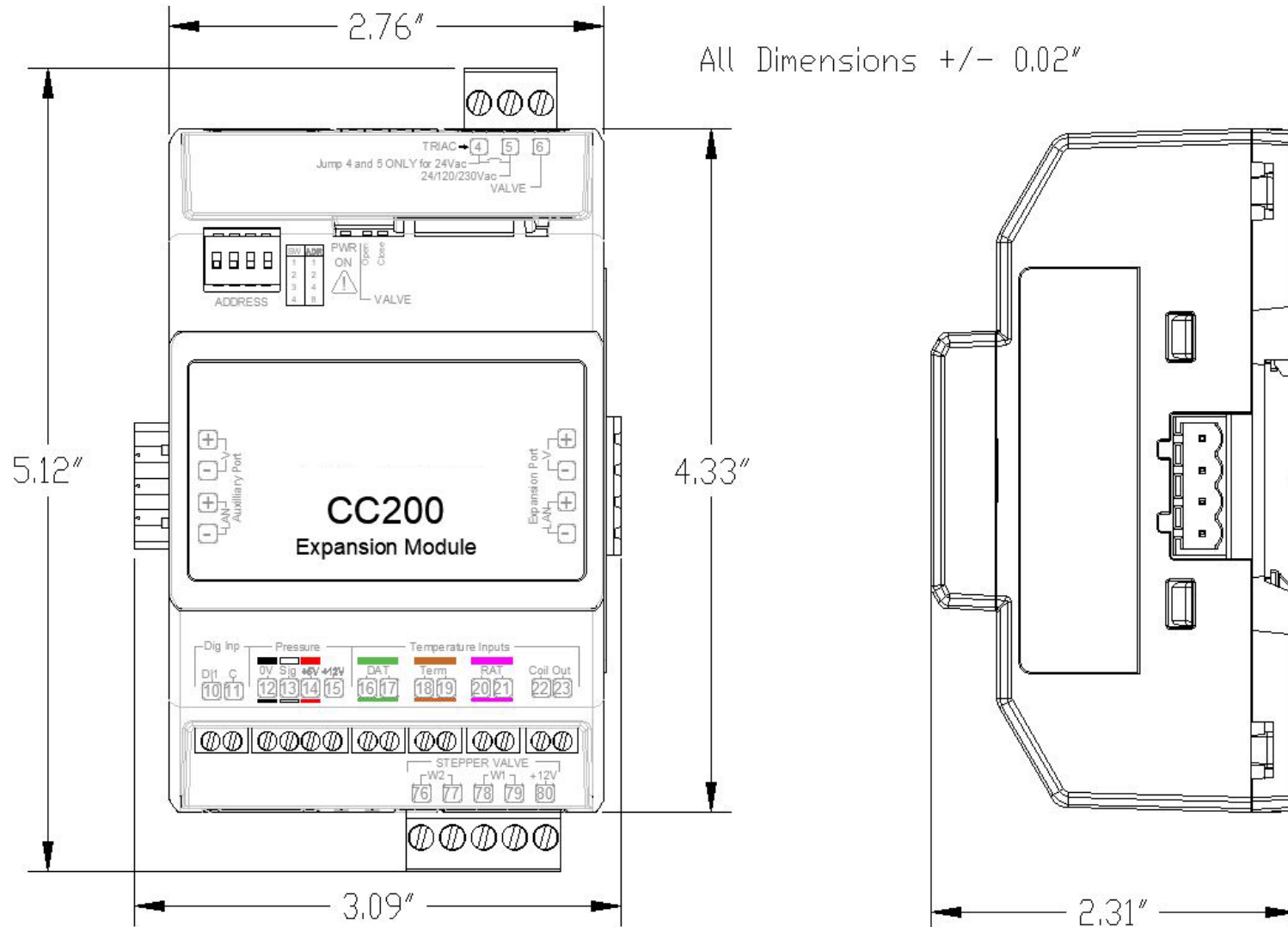

CC200 Expansion Module Dimensions P/N 318-3181

Appendix B: Dimensions

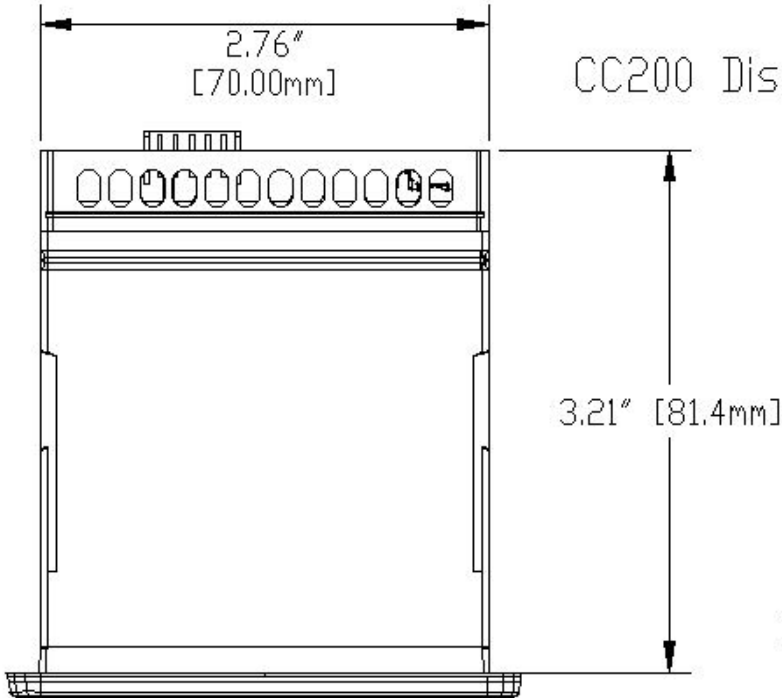

CC200 Display PN 318-3182

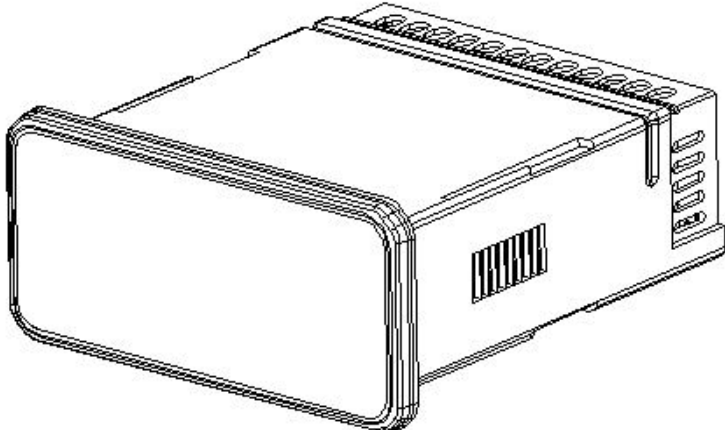

DIMENSIONS: INCH [mm]

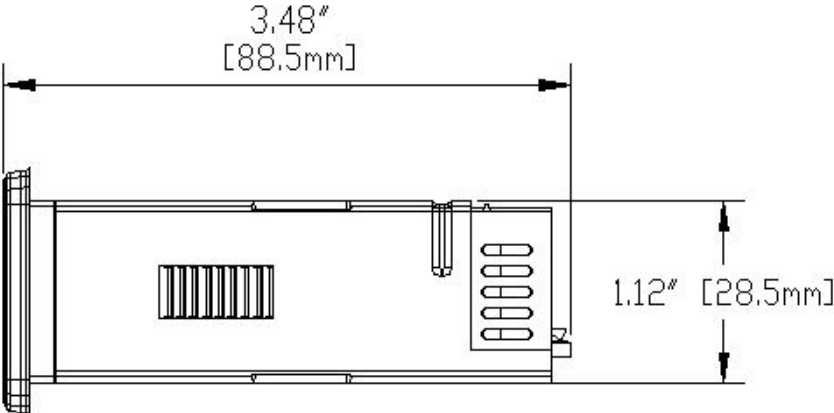
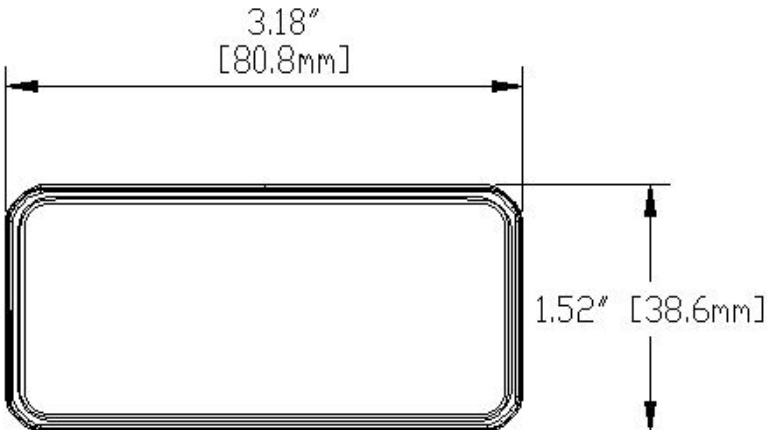

CC200 Display Dimensions P/N 318-3182

Appendix B: Dimensions

60 Watt Power Supply PN 318-3183

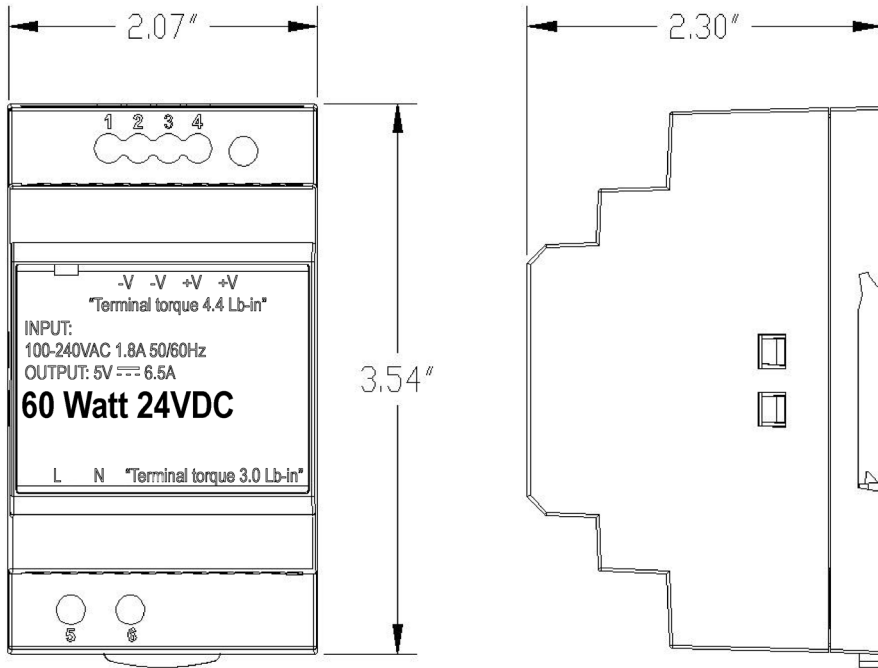

All Dimensions +/- 0.02"

60-Watt Power Supply Dimensions P/N 318-3183

92 Watt Power Supply PN 318-3184

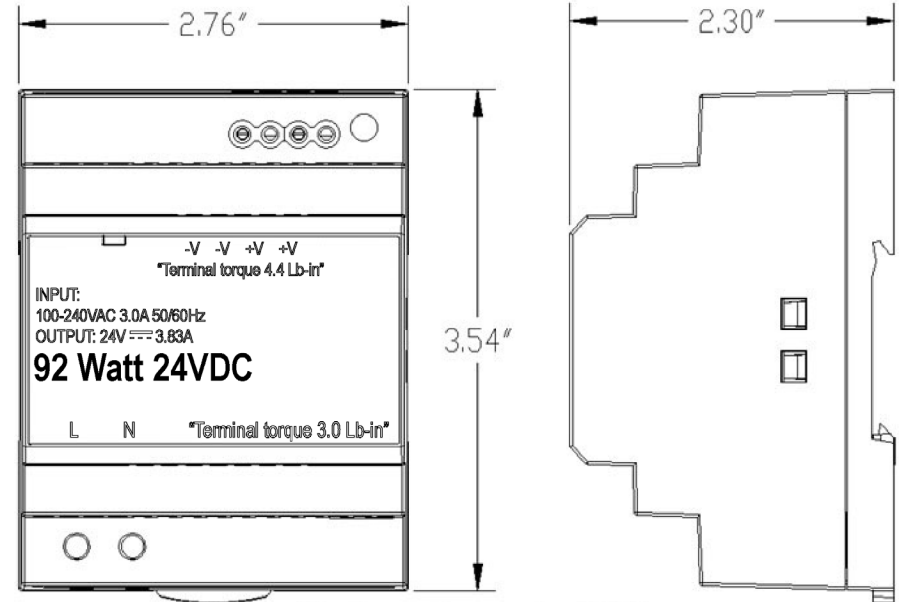

All Dimensions +/- 0.02"

92-Watt Power Supply Dimensions P/N 318-3184

Appendix C: Door Switch Mounting and Wiring Hinged Doors

Door Switch PN 118-4101 L-Bracket and Contact Mounting for Hinged Doors

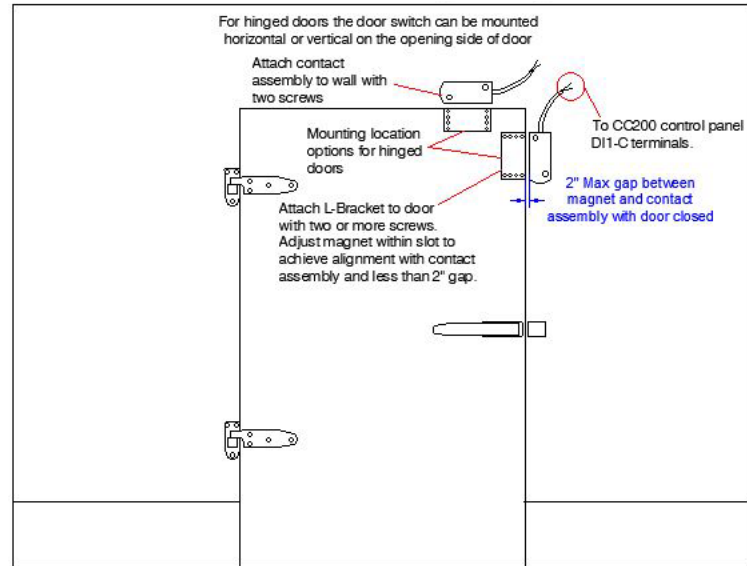

CC200 Door Switch Wiring

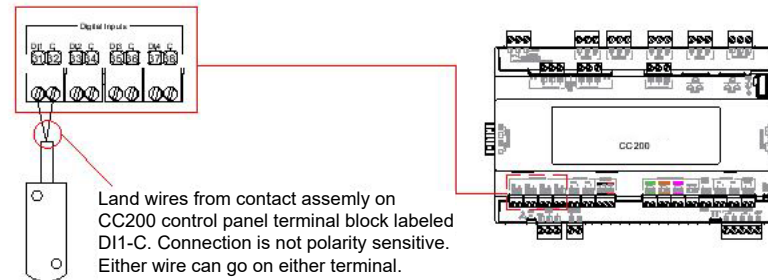

Land wires from contact assembly on CC200 control panel terminal block labeled DI1-C. Connection is not polarity sensitive. Either wire can go on either terminal. If contact assembly leads need to be extended use shielded 22AWG/2 cable: Copeland PN 135-0600, Copeland PN 035-0002, Belden 8761 or equivalent. Heat shrink and solder splices. Provide junction box and/or conduit in compliance with customer project specifications.

118-4101 Door Switch Mounting for Hinged Doors

Appendix D: Door Switch Mounting and Wiring Sliding Doors

Door Switch PN 118-4101 L-Bracket and Contact Mounting for Hinged Doors

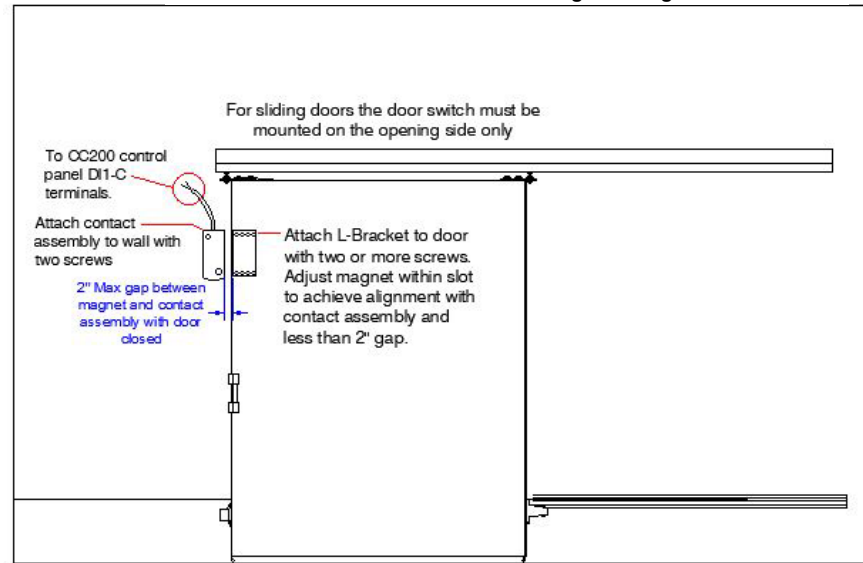

CC200 Door Switch Wiring

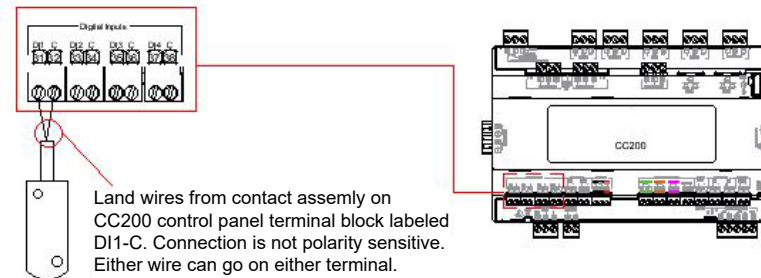

If contact assembly leads need to be extended use shielded 22AWG/2 cable: Copeland PN 135-0600, Copeland PN 035-0002, Belden 8761 or equivalent. Heat shrink and solder splices. Provide junction box and/or conduit in compliance with customer project specifications.

Appendix E: 118-4101 Door Switch Dimensions

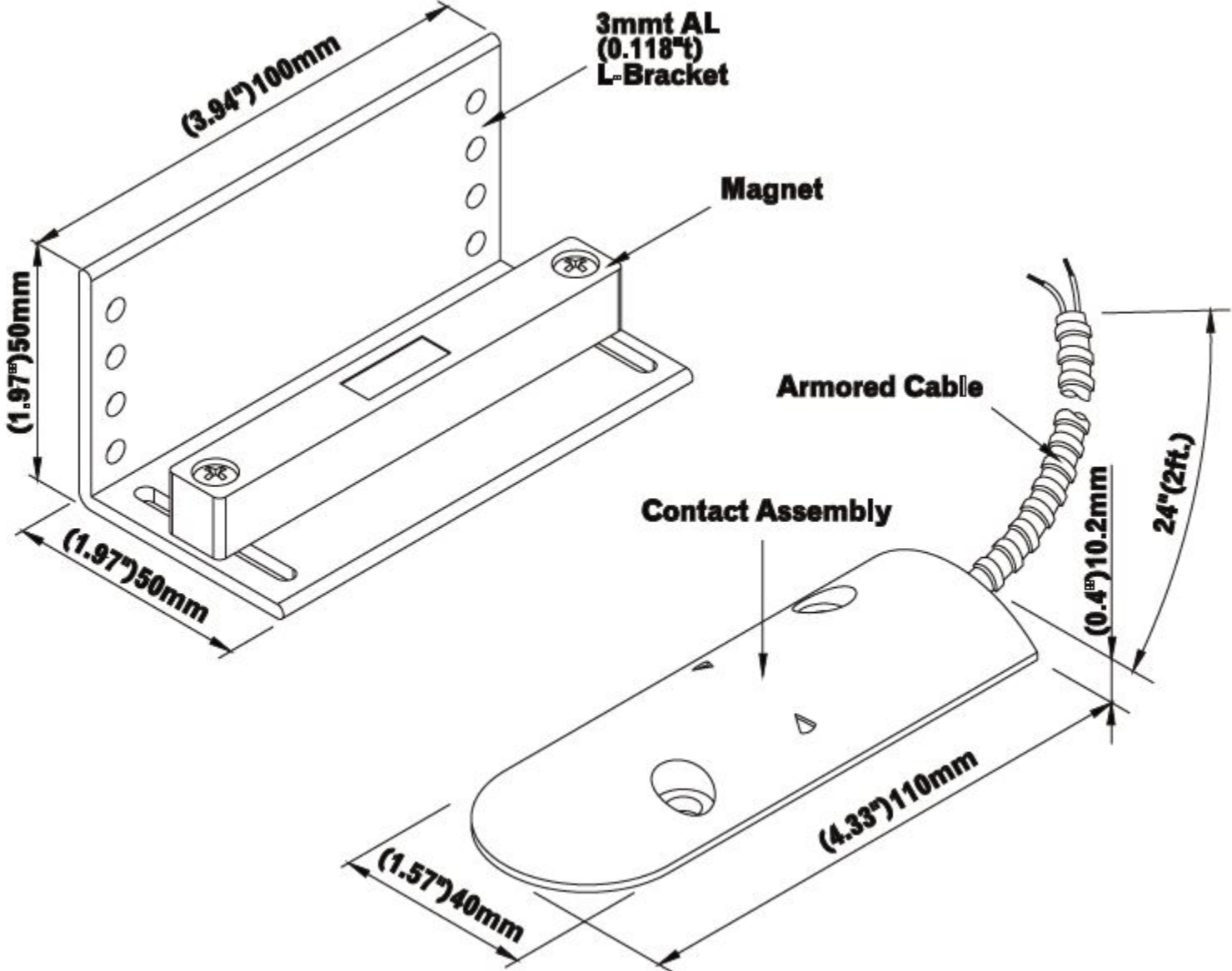

Visit our website at copeland.com/en-us/products/controls-monitoring-systems for the latest technical documentation and updates.
For Technical Support call **833-409-7505** or email ColdChain.TechnicalServices@Copeland.com

The contents of this publication are presented for informational purposes only and they are not to be construed as warranties or guarantees, express or implied, regarding the products or services described herein or their use or applicability. Copeland reserves the right to modify the designs or specifications of such products at any time without notice. Responsibility for proper selection, use and maintenance of any product remains solely with the purchaser and end-user. ©2024 Copeland is a trademark of Copeland LP.