

# E2 2.40 and Above Interface with Variable-Speed Drives (VSD)

## Overview

Beginning with version 2.40, the E2 RX, BX, and CX series of controllers will feature integration with several models of variable-speed drives (VSDs) manufactured by Control Techniques™. The E2 communicates with the CT VSD via an RS485 MODBUS network, which allows easier wiring setup and more detailed status and fault information to be communicated to the E2 than traditional VSDs driven with I/O points.

All E2 control applications that can use VSDs — such as variable-speed condenser fans, AHU fans, and VS compressors — support selection of drives, making software setup quicker and easier.

## Compatible CT Drives

The E2 controller's RS485 MODBUS interface communicates with the following CT VSD models:

- Commander SK
- Commander SE
- Unidrive SP

## Before Beginning Setup

The networking and configuration instructions in this technical bulletin assume the VSDs are properly installed, tuned, and programmed by the installer. It is critical that the proper filters, wiring, shielding, and grounding are done to minimize the EMI generated by these drives. The following is a list of items that must be addressed to ensure proper system operation. Refer to the manufacturer's drive manual on how to do the following:

1. Fitting the correct RFI filter(s) at the power input to the drive,
2. Mounting the drive against the surface of the RFI filter correctly, removing all paint or non-conducting coatings so that the drive and the RFI filter make good direct electrical contact,
3. Ensuring the filter is connected to the drive using only the wires provided (with no extensions),
4. Using a shielded (screened) or steel wire armored cable to connect the drive to the motor, with the shield connected to the drive gland plate by a good high-frequency connection (using either the conductive cable glands or the SE11 optional cable screen clamp kit),
5. Grounding the shield of the motor cable to the ground terminal of the motor frame using a link that is as short as possible and not exceeding 50 mm (2 in) in length (a full 360° termination of the shield to the motor terminal housing, if metal, is beneficial),
6. Ensuring the cables carrying the AC supply and the ground to the filter are at least 100 mm (4 in) from the drive and motor cable,
7. Avoiding locating noise-sensitive circuits in a zone extending 0.3m (12 inches) all around the drive, and
8. Ensuring the motor cables do NOT run in parallel with control signal cables.

Proper setting of the drive setpoints themselves is beyond the scope of this document. For information about CT drive setpoints and their functions, consult the manufacturer's instructions.

# MODBUS Networking

CT VSD drives connect to an E2 using an RS485 network. Multiple VSDs must be interconnected in a daisy-chain without branches or star configurations, as shown below. Use only Belden 8761 shielded two-wire cable or equivalent.

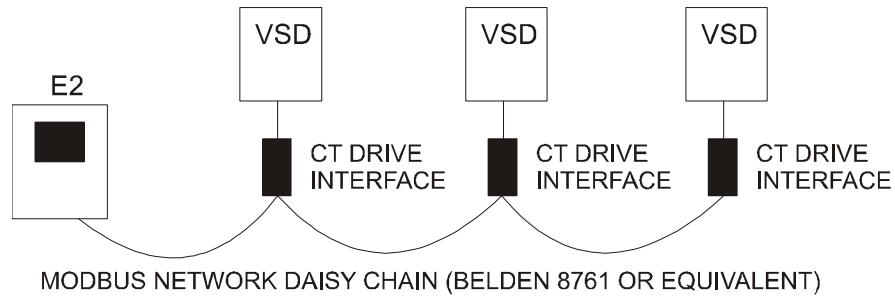

Figure 1 - MODBUS Daisy Chain for CT VSD Drives



**WARNING**

Consult the manufacturer's technical manual for your drive(s) for proper wiring, grounding, and noise prevention. Failure to do so may result in excessive noise disrupting RS485 communication.

Use only Belden 8761 or equivalent for networking the VSDs. CAT5 cabling and other cable that typically uses RJ45 connectors like the one on the VSD are not rated for use with VSDs.

## Connection to E2

The E2 supports MODBUS on any of its RS485 serial ports. These include:

- **COM2** - The RS485 serial port onboard the E2 Power Interface Board (PIB). All E2 models have a COM2 port, which is typically used by the Copeland I/O Network but may also be designated as a MODBUS port.
- **COM4** - The RS485 serial port on the RS485 COM Card (P/N 637-4890), a peripheral board that must be purchased separately.
- **COM6** - The RS485 serial port on the E2 Modem/Expansion COM Card (P/Ns 637-4871, 637-4872, and 637-4873), a peripheral board that must be purchased separately.

The connectors for the COM2, COM4, and COM6 ports are shown in . Note that the COM port assigned for use as MODBUS may not be used to communicate with Copeland I/O boards or any other type of serial device - only MODBUS devices may be connected to the port.

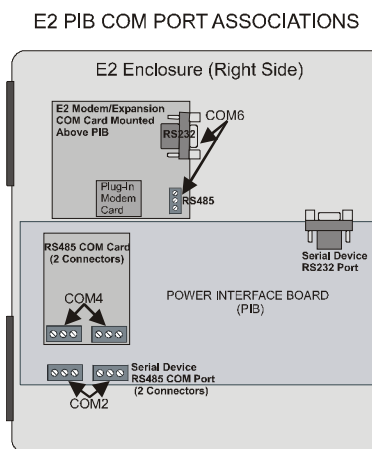

Figure 2 - E2 PIB COM Port Locations

## Connection to VSDs and the CT Drive Interface

Copeland requires that all MODBUS network connections to VSDs use a CT Drive Interface (P/N 535-2725). This assembly, which plugs into the RJ45 MODBUS jack on the VSD, provides the noise filtering circuitry recommended by the VSD manufacturer, and it also provides a screw terminal connector for easier daisy chaining to the MODBUS network.

1. Using the shielded Ethernet cable included in the CT Drive Interface Kit, connect the CT Drive Interface box to the RJ45 jack on the VSD. Do not use any other Ethernet cable except the cable supplied in the CT Drive Interface kit.
2. Connect the MODBUS network cable to the RS485 network connector on the CT Drive Interface. Wire all 485+ terminals on the E2 and CT Drive Interfaces to the same wire color, and wire all 485- terminals to the other wire color. All bare shield wires should be connected to the 0V terminals. The 0V terminal must also be connected to earth ground with a 14AWG wire no longer than 6 inches. You may use the earth ground connection on the motor drive. Refer to .
3. Terminate the two devices at the endpoints of the MODBUS daisy chain. For the E2, the termination jumpers will be next to the COM port connector. For the CT VSDs, use the termination jumpers on the CT Drive Interface. Set the jumpers of the end devices to the TERMINATED positions and all other devices to the UNTERMINATED position. Refer to .

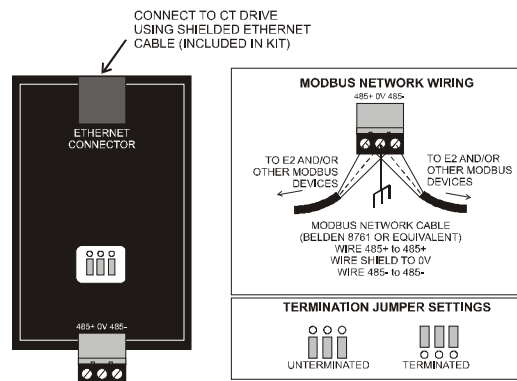

Figure 3 - CT Drive Interface Wiring and Termination Settings

## Manually Configuring the VSDs to Enable MODBUS Communication

By default, a VSD is not configured with the right parameter settings to communicate via MODBUS. Before connecting to an E2, you must use the CT Drive's own keypad interface to change serial networking parameter values. The list below shows the ID number of each parameter that must be changed for each model type. Refer to the drive manufacturer's instructions for more information about using the CT Drive keypad interface.

- **Commander SE:**
  - 41 - SERIAL MODE: Change to "rtU"
  - 42 - BAUD RATE: Recommended value is "9.6" for 9600 baud.
  - 43 - SERIAL ADDRESS: Choose a unique MODBUS address number from 1 to 127. The SE drive displays MODBUS addresses with a decimal point (for example, 10 is displayed as "1.0", and 2 is displayed as "0.2"). Ignore the decimal point.
- **Commander SK:**
  - 43 - SERIAL COMMS BAUD RATE: Recommended value is "9.6" for 9600 baud.
  - 44 - SERIAL COMMS ADDRESS: Choose a unique MODBUS address number from 1 to 127.
- **Unidrive SP:**
  - 35 - SERIAL MODE: Change to "rtU"
  - 36 - SERIAL COMMUNICATION BAUD RATE: Recommended value is "9.6" for 9600 baud.
  - 37 - SERIAL COMMUNICATIONS ADDRESS: Choose a unique MODBUS address number from 1 to 127.









## Sharing the MODBUS Network with Other MODBUS Devices

VSDs may share the same network segment as other MODBUS devices communicating with the E2, provided:







- Each device, regardless of type, has a unique MODBUS address from 1 to 127. In other words, if there are two CT VSDs and five Control Link Case Displays (CL-CDs) on the MODBUS network, do not number the VSDs 1-2 and the Control Link Case Displays 1-5. You must either number the VSDs 1-2 and the CL-CDs 3-7, or the CL-CDs 1-5 and the VSDs 6-7.
- Each device uses the same baud rate and parity type.
- The number of total devices does not exceed 127.

## Adding and Commissioning CT VSD Drives

Once the VSDs are networked properly, assign the E2 COM port to which the VSDs are connected as a MODBUS port, and specify the number of drives on the network.

1. Log in to the E2 controller with a username/password that has Level 4 (Administrator) access.
2. Press  &  &  &  (GENERAL CONTROLLER INFORMATION).
3. Port assignments are made in the **Serial** tab of the **General Controller Information** setup screens. Press  +  to navigate to the **Serial Configuration** screen.
4. In the COM Connection field that corresponds to the COM port number to which the VSDs are connected, press  - **LOOK UP** and select **MODBUS**.
5. After selecting **MODBUS**, four fields will appear below the COM Connection field. These fields define the format of the messages coming from the VSDs and must be set to the following values:
  - *Baud Rate* - All CT VSDs default to 4800 baud, but may be configured to communicate at 9600 or 19200 baud. If you want to use the VSD's default baud rate, set this parameter to 4800. Otherwise, choose 9600 or 19200 baud, and change the baud rate parameter in each VSD on the network to the baud rate you entered in the E2. Consult the VSD drive's documentation for instructions on changing VSD baud rate settings.
  - *Data Size* - 8
  - *Parity* - None
  - *Stop Bits* - All CT VSD Drives use 2 stop bits, but since all other MODBUS-enabled Copeland devices use 1 stop bit, the E2 has been programmed to automatically use 2 stop bits in messaging to CT VSD devices only. Therefore it is recommended you leave the **Stop Bits** field set to 1.
6. When you have finished entering the MODBUS settings, press  to save changes and return to the **System Information** menu.

After configuring the network, specify the number of VSDs on the MODBUS network, and run a MODBUS network scan so E2 can initialize communications with the VSDs:

1. Press  &  &  &  (CONNECTED I/O BOARDS AND CONTROLLERS).
2. In the **Connected I/O** screen, locate the field in the **ECT Devices** box labeled "**CT Drive**." Enter the total number of VSDs on the network in this field.
3. Press  to save changes and return to the **Network Setup** menu.
4. From the **Network Setup** menu, press  - **Controller Setup**.
5. The VSDs you added will be listed on this screen, with model type "**CT Drive**". Using the arrow keys, highlight the name of each CT Drive and, if desired, change the value of each device's **Name** field to something more descriptive of the drive's location or function.

6. When all devices are named, set the MODBUS address for each device. There are two ways to do this:
  - Highlight each device, and press **F4** - **SET ADDRESS** followed by **#1** - **SELECT ADDRESS**. Using the arrow keys, highlight the number that corresponds to the MODBUS address of the device you are configuring. The list also shows which MODBUS addresses are unused and which are assigned to other devices.
  - OR -
  - Highlight any of the VSDs and press **F4** - **SET ADDRESS** followed by **#3** - **Scan Network for ECT Devices**. This feature will auto-detect all MODBUS devices within a specified range of numbers and commission them. Enter the lowest-numbered VSD address in the Starting Address field, the highest-numbered VSD address in the Ending Address field, and press **Enter** to begin the scan. If numbered and networked correctly, the E2 will detect each VSD and commission it in E2 with the proper MODBUS address.
7. When all VSDs are commissioned, press  to return to the Network Setup menu, and press **#1** - **Online Status**. Verify in the Online Status screen that the CT Drives are communicating properly. The status for each CT Drive should read **"Online."**



## Troubleshooting

If one or more CT VSDs fail to commission or stay online, the most likely cause is excess noise on the MODBUS network. Because variable-speed drives generate large amounts of noise, the MODBUS network wiring must be carefully configured, or else coupled noise on the network wire will disrupt communication.

Copeland User Manual P/N 026-1903, "E2 Controller Wiring Practices, Section 2.1" covers proper network wiring and grounding practices as they apply to CT VSD installations. Consult this technical bulletin as well as the manufacturer's information for troubleshooting information.

## Configuring the CT VSD Using E2

Once a VSD is networked and commissioned properly, the application that serves as the drive's interface must be loaded with the setpoints in the VSD. The E2 automatically reads setpoints from the VSD when the model type and MODBUS address is entered in the E2's CT Drive application:

1. Press  **#5** - **Configured Applications**.
2. Press **#3 & #7** to select the application type **"CT Drive."**
3. If multiple CT Drives are set up, highlight the name of the drive you wish to set up and press .
4. The CT Drive Status screen should be visible. From this screen, press **F5** to access the CT Drive setup screens. The first setup screen shown will be **"General."**

### Screen 1: General

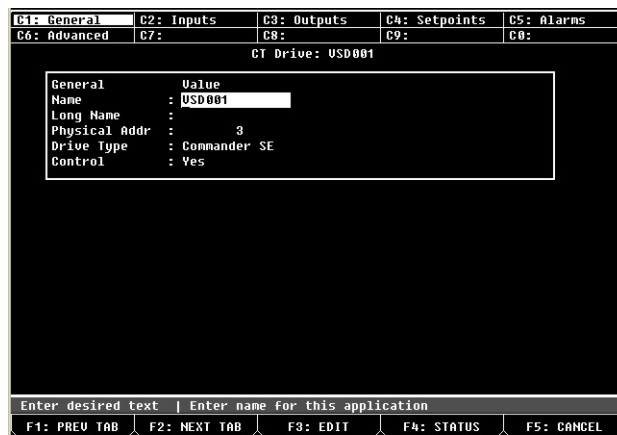

Figure 4 - CT Screen 1: General

5. Enter a name for the VSD in the **"Name"** field.
6. Enter the MODBUS address for this drive in the **"Physical Addr"** field.
7. Choose the VSD model type (**Commander SK**, **Commander SE**, or **UniDrive SP**) in the **Drive Type** field.

8. Press  to save these changes and exit to the **CT Drive Status** screen.

When you return to the CT Drive Status screen, you should see live values appearing in the “**Current Conditions**” status fields (such as Hz/RPM) as the E2 makes connections between the CT Drive application inputs and outputs and the VSD’s inputs and outputs.

The final step in CT Drive setup is to associate the VSD with the application that will be commanding it.







## CT VSD Association With E2 Control Applications

Most E2 control applications that can use variable-speed drives may be associated with CT VSDs. They are:









- Suction Group and Enhanced Suction Group (for controlling variable-speed compressors)
- Condenser (for controlling variable-speed fans)
- AHU (for controlling variable-speed blowers)

To associate an application with a CT VSD, navigate to the application’s setup screens, locate the field that determines device type or fan type, and set that field to “**CT Drive**.”

### Condenser & AHU

1. Press  **F5** - **Configured Applications**.
2. Highlight either “**Condenser**” or “**AHU**” in the **Configured Apps** menu, and press .
3. If more than one application, highlight the name of the application you wish to set up in the **Summary Screen** and press .
4. From the status screen, press  to access the application setup screens.
5. Locate the “**Fan Type**” field on screen **C1: General**. Highlight this field, press , and select “**CT Drive**” as the fan type.
6. Navigate to the screen where the advanced VS setup parameters are (screen **C4: VS Setup for Condensers**, screen **C8: Adv Fan**).
7. Locate the field named “**CT Drive**.” Highlight this field, press , and select the name of the CT Drive application you wish to assign to this application.
8. Press  to save changes and exit.

### Suction Group & Enhanced Suction Group

1. Press  **F5** - **Configured Applications**.
2. Highlight either “**Suction Group**” or “**Enhanced Suction Group**” in the **Configured Apps** menu, and press .
3. If more than one application, highlight the name of the application you wish to set up in the **Summary Screen** and press .
4. From the status screen, press  to access the application setup screens.
5. In **Screen 1: General**, if you have not set up the total number of compressor stages in the rack, enter the correct number in the “**Num of Stages**” field. This will cause the **C6: Comp Setup** tab to be visible.
6. Press  **F6** to navigate to the **Comp Outs** screen.
7. For stage #1 in the **Comp Outs** screen, highlight the “**TYPE**” field and set this field to “**CTdr**” (**CT Drive**). This assigns stage 1 of the rack to be a VS compressor driven by a CT VSD.
8. Press  **F8** to navigate to the **VS** screen.
9. Locate the field named “**CT Drive**.” Highlight this field, press , and select the name of the CT Drive application you wish to assign to this application.
10. Press  to save changes and exit.

When a CT Drive application is associated with a control application, the E2 automatically connects all of the necessary inputs and outputs of the CT Drive to the inputs and outputs of the control application that are responsible for: controlling the drive's forward/run (RUN) and variable speed percentage (VS); resetting the inverter (INV RST); reading the motor frequency (MOTOR FREQ); and reading the inverter's alarm output state (ALARM OUT).

## *Configuration and Synchronizing Configuration Between the E2 and CT VSDs*

The setpoints that determine how the VSD operates are kept and saved in the VSD's own memory. When the E2 makes the connection between a VSD and a CT Drive application (see "[Configuring the CT VSD Using E2](#)" on page 5), the setpoints are read from the VSD and saved to the E2's application configuration. When this occurs, the configurations between the E2 and VSD are considered "synchronized."

After the initial read from the VSD occurs, as long as the VSD is associated with a CT Drive application in the E2, the E2 will be considered the primary device when keeping the setpoints synchronized between the E2 and VSD. This means:

- All permanent changes to CT Drive setpoints must be made through the E2's CT Drive application. Changes made through the E2 are saved to the VSD as permanent.
- All changes made from the VSD's front panel are temporary and will eventually be overwritten by the configuration in the CT Drive. The E2 checks once daily for out-of-synch conditions between the setpoints in the CT Drive application and the VSD, and all setpoints that are different from the values stored in the CT Drive application will be overwritten.

### Using Application Commands to Force Config Synchronization

If desired, you may manually force configuration synchronization to occur between the CT Drive application and the VSD.

Visit our website at [copeland.com/en-us/products/controls-monitoring-systems](https://copeland.com/en-us/products/controls-monitoring-systems) for the latest technical documentation and updates.

For Technical Support call **833-409-7505** or email [ColdChain.TechnicalServices@Copeland.com](mailto:ColdChain.TechnicalServices@Copeland.com)