



E2 Controller Wiring Practices





ALL RIGHTS RESERVED

The information contained in this manual has been carefully checked and is believed to be accurate. However, Computer Process Controls, Inc. assumes no responsibility for any inaccuracies that may be contained herein. In no event will Computer Process Controls, Inc. be liable for any direct, indirect, special, incidental, or consequential damages resulting from any defect or omission in this manual, even if advised of the possibility of such damages. In the interest of continued product development, Computer Process Controls, Inc. reserves the right to make improvements to this manual, and the products described herein, at any time without notice or obligation.

FCC COMPLIANCE NOTICE

This device complies with Part 15 of the FCC Rules. Operation is subject to the following two conditions: (1) this device may not cause harmful interference, and (2) this device must accept any interference received, including interference that may cause undesired operation.

CE COMPLIANCE NOTICE

Class A Product Information for Einstein, E2 Controllers:

The CPC Einstein and E2 controllers are Class A products. In a domestic environment this product may cause radio interference in which case the user may be required to take adequate measures. This covers:

- All Einstein family product types: RX - Refrigeration Controller (830-xxxx), BX - Building/HVAC Controller (831-xxxx), and all version models: (300, 400, 500).
- All E2 family product types: RX - Refrigeration Controller (834-xxxx), BX - Building/HVAC Controller (835-xxxx), CX- Convenience Store Controller (836-xxxx), and all version models: (300, 400, 500).

Table of Contents

1 OVERVIEW	1
1.1. “NOISE” AND ITS EFFECTS.....	1
1.2. SOURCES OF NOISE.....	1
2 AVOIDING NOISE-GENERATING DEVICES	2
2.1. CONTROL TECHNIQUES VARIABLE-SPEED DRIVES	2
3 AVOIDING HIGH VOLTAGE WIRING	3
4 USING THE CORRECT CABLE	4
4.1. RS485 COMMUNICATION WIRING.....	4
4.2. ANALOG OUTPUT WIRING (CONTROL TECHNIQUES VSDBS).....	4
4.3. ECHELON NETWORK WIRING	4
4.4. ETHERNET NETWORK WIRING	4
4.4.1. <i>Shielding</i>	4
4.4.2. <i>Maximum Cable Length</i>	5
5 POWER WIRE GAGE SELECTION	6
6 NETWORK STRUCTURE, BIASING, AND TERMINATION RESISTANCE	7
6.1. RS485 NETWORKING.....	7
6.1.1. <i>Terminating and Biasing an I/O Networks and MODBUS Networks</i>	7
6.2. ECHELON NETWORKING	8
6.2.1. <i>Echelon Network Termination</i>	9
7 CABLE AND DEVICE GROUNDING	10
7.1. GENERAL GROUNDING GUIDELINES.....	10
7.1.1. <i>Ground Wire Specifications</i>	10
7.1.2. <i>Ground Source Specifications</i>	10
7.2. POWER INPUT AND RS485/MODBUS GROUNDING	10
7.2.1. <i>E2</i>	10
7.2.2. <i>RS485 I/O and MODBUS Devices (except Control Link)</i>	11
7.2.3. <i>Control Link Modules</i>	11
7.3. EMI-RESISTANT RS485 NETWORK GROUNDING PRACTICES	11
7.4. VSD DRIVE GROUNDING PRACTICES.....	12
7.4.1. <i>Analog Output Cable Grounding</i>	13
7.5. ECHELON CABLE GROUNDING	13
7.5.1. <i>EMI-Resistant Echelon Network Grounding (For High-EMI Environments)</i>	13

1 Overview

One of the most common causes of communication problems experienced by CPC site controllers is excess electromagnetic interference (EMI), commonly referred to as electrical noise or just “noise.” Because refrigeration and HVAC controls are typically installed in motor rooms and utility rooms, they are often in close proximity to other electrical devices that generate EMI, such as power lines or motors.

Noise can be picked up by any length of wire. Just as an antenna helps a radio receive AM and FM radio signals, a long length of wire between a controller and I/O board or sensor can also act as an antenna for noise.

CPC site controllers such as the E2, as well as the peripheral I/O boards and unit controllers to which it communicates, go through rigorous testing to ensure (1) that they are not overly susceptible to noise, and (2) that the devices themselves do not generate excess noise. Regardless, **every long wire used in network, power, and signal wiring can potentially be an antenna for EMI.** Unless proper noise abatement wiring practices are used, even one wiring mistake could result in enough noise to impede or disable an RS485, Echelon, or Ethernet network.

This document is meant to provide a list of guidelines that should always be followed when wiring RS485 (I/O networks, MODBUS), Echelon, and Ethernet networks in an E2 control system.

1.1. “Noise” and its Effects

Noise, in the context of this document, refers to EMI induced on a network wire or connector that result in signals that hinder the controllers’ ability to receive and send network messages. Just as loud audio noise in a room makes it harder for people to communicate with each other through speech, a noisy network makes it hard for a control device to read messages sent from other controllers.

You should suspect a noisy network if your E2 control system experiences any of the following problems:

- Periodic outages of communication between the main controller (E2) and its peripheral devices. This is most often indicated by a large number of “Controller Offline” alarms in the E2 Alarm Log, which usually return to normal.
- Inability to commission devices during setup. During commissioning, the E2 attempts to find a device and read its commissioning information - on a noisy network, the E2 may fail to find devices or require several retries before finding them. Noise may also cause commissioning to proceed very slowly.
- Intermittent Ethernet connections to E2 (ping works, but UltraSite or InSite cannot make connection to the E2).
- Communication outages that occur when changes are made to network connections to the E2. Example: the I/O network devices stop communicating when the Ethernet cable is plugged into the E2.
- Reboots of the E2, in situations where excessive noise is present.

1.2. Sources of Noise

The most common causes of noise in an E2 controller installation are:

- Wiring that comes close to an electrical device that generates lots of noise,
- Routing cable that runs parallel and/or in close proximity to wires that carry high AC voltage and current,
- Network cable that does not meet specifications,
- Power wiring from the transformer secondary that is the wrong wire gage,
- Improper network structure or termination resistance, and
- Cable that is not grounded or that is grounded improperly.

2 Avoiding Noise-Generating Devices

There are a number of electrical devices commonly used in supermarkets and buildings that generate noise.

- Motor starters, contactors, or other electrical equipment that switches ON and OFF. Switching heavy electrical loads ON and OFF will generate noise.
- Inverters for variable-speed motors. Inverters generate a constant amount of high levels of noise.
- Fluorescent light ballasts. Light ballasts also generate constant noise.
- Arc welders (excessive intermittent noise).

The best way to eliminate network noise coming from a noise-generating device is to keep all networked devices and cable runs as far away from the device as possible. Cable runs should be routed around noise-generating devices, and the E2 (as well as the devices the E2 is networked with) should be physically located far away from noise-generating devices.

The minimum distance devices and cabling should be kept away from noise generators is **1 ft. (0.3m) with 5 ft. (1.5 m) being the ideal minimum distance.** The minimum distance may be more or less depending on the amount of noise generated by the device - refer to the device's user manual for more information.

2.1. Control Techniques Variable-Speed Drives

E2 controllers whose versions are 2.40F01 and above feature the ability to communicate with certain models of Control Techniques variable-speed drives (VSDs) using a MODBUS network connection.

Control Techniques and CPC both require all VSDs that will network with E2 controllers to be installed with line filters to minimize noise. If installing an E2 network into a site that already has installed VSDs, verify the drives were installed with line filters before networking them to an E2. Contact your Control Techniques representative to obtain line filters and assistance with installation.

In addition, CPC requires that all MODBUS network connections to Control Techniques VSDs use a CT Drive Interface (*P/N 535-2725*). This assembly, which plugs into the RJ45 MODBUS jack on the VSD, provides the noise filtering circuitry recommended by Control Techniques, and it also provides a screw terminal connector for easier daisy chaining to the MODBUS network.

For further information on noise abatement when using Control Techniques VSDs, consult the manufacturer's instructions and follow all recommended guidelines for installing the drive and reducing noise. Furthermore, when using VSDs, it is highly recommended you follow the EMI-resistant wiring guidelines outlined in **Section 7.3., EMI-Resistant RS485 Network Grounding Practices.**

3 Avoiding High Voltage Wiring

A common mistake made by wiring technicians is to wire communication cabling in parallel with 120VAC, 240VAC, or 480VAC power wiring (sometimes together in the same conduit). High voltage wiring radiates noise in all directions perpendicular from the direction of the wire. When a communication wire is run parallel and in close proximity to a high voltage wire, the electromagnetic field from the high voltage wire will induce noise on the communication cable. The amount of noise induced depends on the voltage and current of the wire, the distance between the two wires, and the angle between the two wire runs (with parallel being the highest induction).

To avoid noise induced from high-voltage wiring:

1. If possible, wire serial, Echelon, and Ethernet wiring away from high-voltage wire. Communication cabling should be kept a **minimum of 3 in. (7.6 cm) apart at all points, with 12 in. (30 cm) being the ideal minimum distance.**
2. Do not wire communication wire and high-voltage wire in the same conduit. Always separate the power wiring in a separate grounded rigid steel conduit if the two wires must be run close together and in parallel.
3. Avoid running even part of the communication wiring in close parallel with high voltage wiring. A run of parallel wire as short as a few inches could yield enough noise to affect network communication. If the wires must cross each other in close proximity, cross them perpendicularly to each other so the amount of noise is minimized (see *Figure 3-1*).

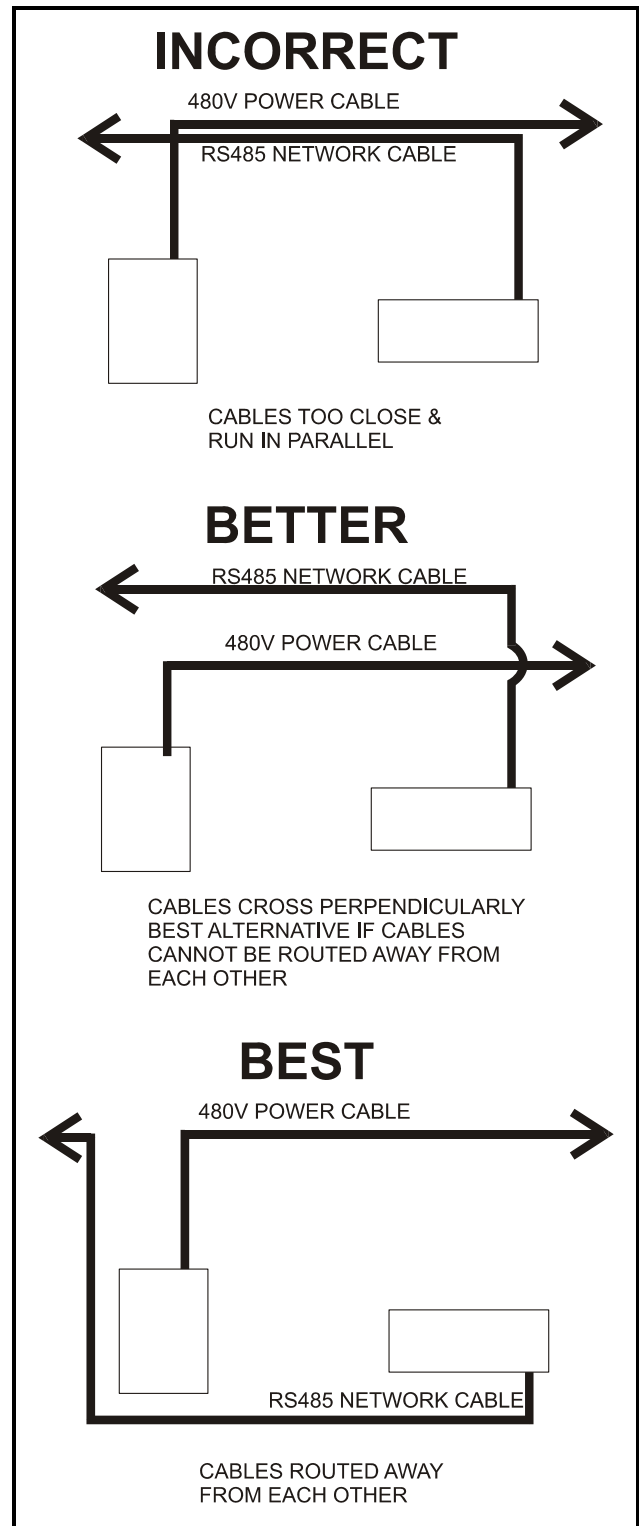

Figure 3-1 - Examples of Good & Bad Cable Routing

4 Using The Correct Cable

4.1. RS485 Communication Wiring

CPC specifies all RS485 I/O and MODBUS wiring used by the E2 must be Belden 8641 (24AWG, 300V, CPC P/N 135-8641); Belden 8761 (22 AWG, 300V not stocked by CPC); or a 600V-shielded 22AWG equivalent stocked by CPC (P/N 135-0600). These are two-connector shielded twisted pair cable that support a maximum daisy chain cable distance of 4000 feet (1219 m) between the E2 and the end device on the network.

Provided the cable can be routed away from noise generators and running in parallel with high-voltage wire, any of the three specified cables will provide adequate shielding from external noise.

4.2. Analog Output Wiring (Control Techniques VSDs)

If using a MultiFlex analog output or 4AO board to drive a Control Techniques VSD, you **MUST** use shielded cable between the analog point and the VSD drive speed input. Use the same two-connector shielded cable specified for RS485 use: Belden 8641 (24AWG, 300V, CPC P/N 135-8641); Belden 8761 (22 AWG, 300V not stocked by CPC); or a 600V-shielded 22AWG equivalent stocked by CPC (P/N 135-0600).

4.3. Echelon Network Wiring

CPC specifies one type of cable for Echelon Network wiring: a Level 4, twisted pair, stranded, shielded cable that meets all requirements for Echelon LonWorks networks. This cable is available in both plenum and non-plenum varieties from CPC (see part numbers in *Table 4-1*). This cable is the only cable type supported by CPC.

Cable Type	CPC Part Number
1 pair, non-plenum	135-2300
1 pair, plenum	135-2301

Table 4-1 - Recommended Wiring

4.4. Ethernet Network Wiring

4.4.1. Shielding

Standard, unshielded CAT5/5e cable can be used for wiring E2s to an Ethernet network as long as the cable is not run near sources of electrical noise. Otherwise, if the cable will be used in a noisy environment, shielded CAT5e cable (Belden 1533, plenum; 1533R for non-plenum) should be used. For this type of cable, you should use shielded RJ45 connectors meant for **solid conductor wire** (L-Com TDS8PC5 or equivalent). When connecting CAT5e cable to shielded RJ45 connectors:

- Carefully strip the outer sheath insulation back 1". Roll back the foil shield insulation and wrap the drain wire around the foil (*Figure 4-1*). Do not remove any insulation from the conductors.
- Untwist the wires to within 1/8" of the jacket. Arrange the wires according to TIE/EAI 586A & 586B (*Figure 4-2*). For straight patch cables, wire both ends 586A; for crossover cables, wire one end 586A and the other 586B. Insert wires into the loading bar. Trim excess wires.
- Hold the connector in front of you with the locking tab down. Orient the wires so connector pin 1 aligns with cable pin 1, etc. (Pin 1 is on the far left). Slide the wires into the CAT5e connector. The cable jacket should extend into the connector about 1/4" for strain relief (*Figure 4-3*).
- Insert the plug into a crimp tool. Firmly squeeze the handles to set the contacts and secure the cable.

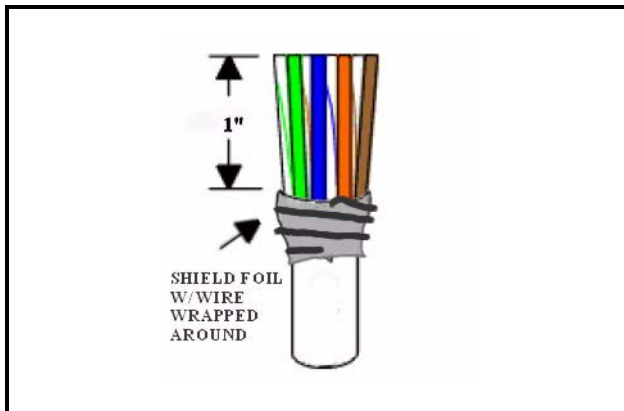

Figure 4-1 - CAT5e Shielded Cable w/ 1" Stripped Jacket

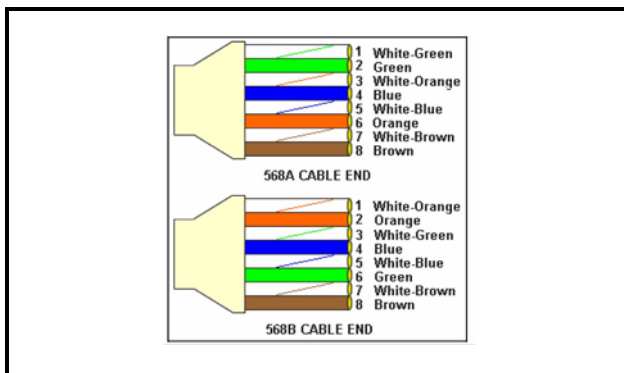

Figure 4-2 - 586A & 586B Cable End Wire Color Diagram

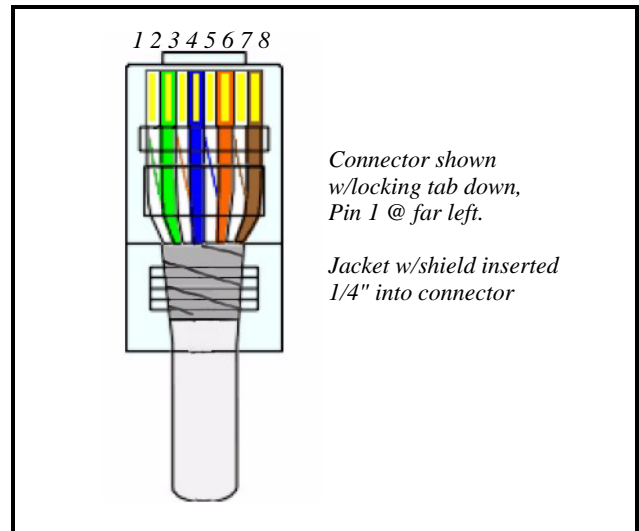

Figure 4-3 - CAT5e Cable End Loaded Into Connector

4.4.2. Maximum Cable Length

An Ethernet cable should be no longer than 328 feet (100 meters) from E2 to switch or hub. Exceeding this length will cause communication problems.

5 Power Wire Gage Selection

The gage of wire used to connect networked devices to the transformer secondary also plays a significant part in noise reduction. Most CPC controllers and I/O devices are powered by 24VAC transformers. Power wiring from the transformer secondary should be either 18AWG, 16AWG, or 14AWG, depending upon the total wire length to all devices and the total VA of all devices powered.

To determine the correct wire gage to use:

1. Add together the VA ratings of all devices that will be powered by the transformer. **Table 5-1** shows the VA devices for the E2 controller and the most common RS485 I/O and Echelon devices used in an E2 control system.

Controller	VA	VAC	Center Tapped?
E2	40	24	No
16AI	5	24	Yes
8RO	15	24	Yes
4AO	10	24	Yes
8DO	18	24	Yes
8IO/ARTC	18	24	No
MultiFlex 16	6	24	Yes
MultiFlex I/O (except ESR)	15	24	No
ESR8	80	24	No
MultiFlex ESR	80	24	Yes
TD3	4	24	No
Gateway	5	24	Yes

Table 5-1 - VA Ratings for CPC I/O Devices

2. Use the total VA calculated in step 1 in the following equations to determine the maximum wire length allowable for each wire gage:
 - 14AWG: $1200 \div (VA)$ (feet)
 - 16AWG: $750 \div (VA)$ (feet)

- 18AWG: $462 \div (VA)$ (feet)
3. Estimate the total length of wire necessary to power the devices, measured from the transformer secondary to the last device that will be connected. Using the maximum wire lengths calculated in step 2, choose a gage of wire whose maximum wire length is longer than the total length of wire you will be using.

Example: A 24VAC transformer will be used to power three MultiFlex 168AOs. The total length of power wire needed is 15 feet. Since the total VA of the three MultiFlex boards is 45VA, 18AWG wire may not be used, since $462 / 45 = 10.2$ feet maximum. 16AWG wire and 14AWG wire may both be used, since with 45VA these wires would have maximum distances of 16.7 ft. and 26.7 ft. respectively.

6 Network Structure, Biasing, and Termination Resistance

6.1. RS485 Networking

The RS485 Input/Output (I/O) Network connects all input and output communication boards together in a single open communications loop. This loop, or “daisy chain,” connects the E2 to multiple input and output communication boards, and terminates at the last input or output board on the network. A diagram of this network arrangement is shown in *Figure 6-1*.

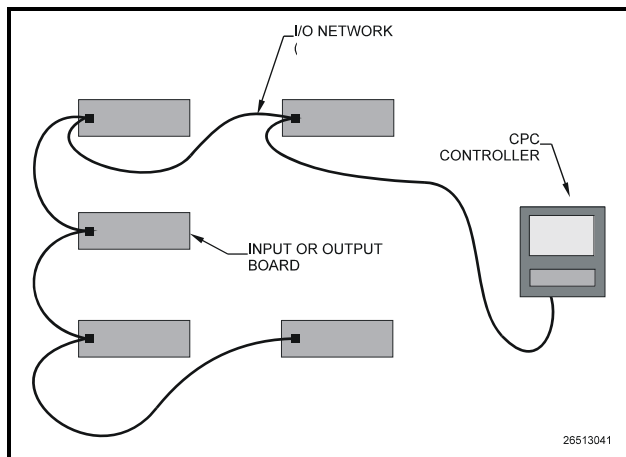

Figure 6-1 - I/O Network Configurations

Daisy chains are the only allowable network structure for CPC RS485 I/O networks. Branching and “star configurations” can seriously affect network performance and therefore are not allowed.

6.1.1. Terminating and Biasing an I/O Networks and MODBUS Networks

Proper termination and biasing is an important part of reducing I/O network noise. All CPC-manufactured devices with RS485 ports are equipped with three on-board jumpers that can provide the resistance necessary to terminate and bias the network endpoint. The middle jumper provides the termination resistance, while the two outside jumpers provide biasing.

I/O Network daisy chains must be terminated AND biased at both ends of the daisy chain (*Figure 6-2*).

MODBUS daisy chains must be terminated at both ends of the daisy chain, but must only be biased at ONE end. Biasing the E2 is the preferred method of network biasing. Most third-party MODBUS devices have no termination or network bias capabilities and will require use of a MODBUS termination block (see **Section 6.1.1.1., MODBUS Termination Blocks**). Others, like the Control Link, have three jumpers similar to CPC I/O devices. For these devices, set the termination jumper (middle) to the UP position and leave the biasing jumpers in the DOWN position. (*Figure 6-2*)

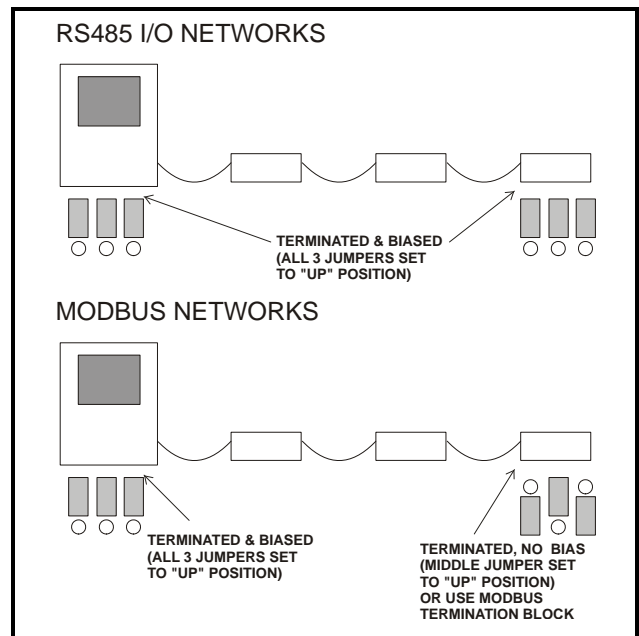

Figure 6-2 - I/O Network and MODBUS Termination and Biasing

6.1.1.1. MODBUS Termination Blocks

Third-party devices may or may not have on-board termination jumpers — consult the manufacturer’s instructions for termination information.

If an end device does not have termination jumpers, CPC offers a termination block that can be used to terminate MODBUS network endpoints (CPC P/N 535-2711). Connect this block just before the end device (*Figure 6-3*) and connect the shield to earth ground, keeping the exposed shield wire length as short as possible (3 inches ideal maximum length).

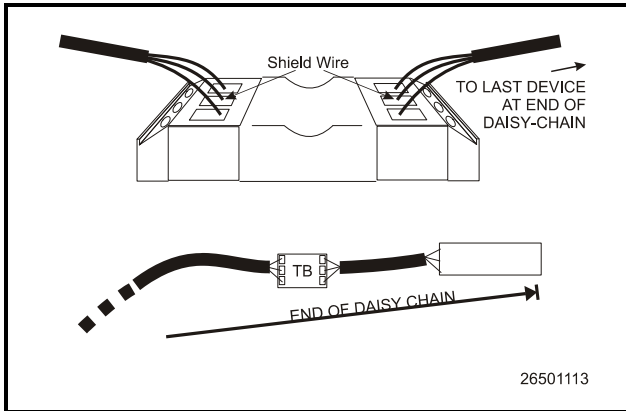

Figure 6-3 - MODBUS Termination Block (P/N 535-2711)

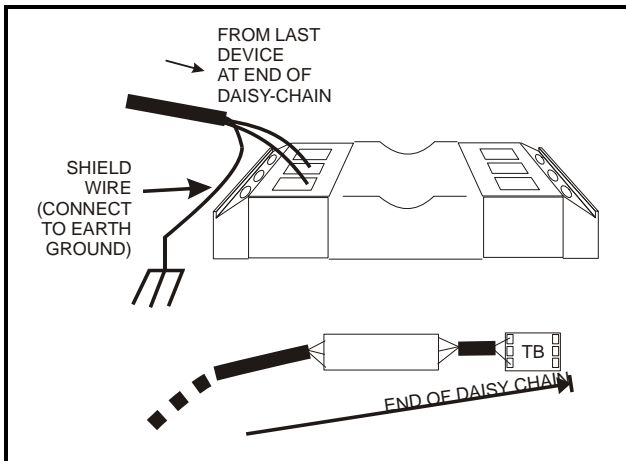

Figure 6-4 - MODBUS Term Block End-of-Chain Install

6.2. Echelon Networking

Echelon devices are networks together into configurations called **segments**. A segment is a group of up to 64 Echelon devices that are connected together on an unbroken series of wires.

The recommended way of constructing an Echelon Network is called **daisy-chaining**. In the daisy-chain network configuration, devices are arranged by **subnets**, which consist of one E2 and all Echelon devices associated with the E2.

First, all devices in a subnet are connected in an unbroken chain without branches or “star configurations” (see *Figure 6-5*). Then, if more than one E2 is present on-site, all chains are connected so that the entire network forms a large unbroken chain, called a daisy chain (see *Figure 6-6*). This allows for all devices in the Echelon Network to be hard wired together for trouble free communication.

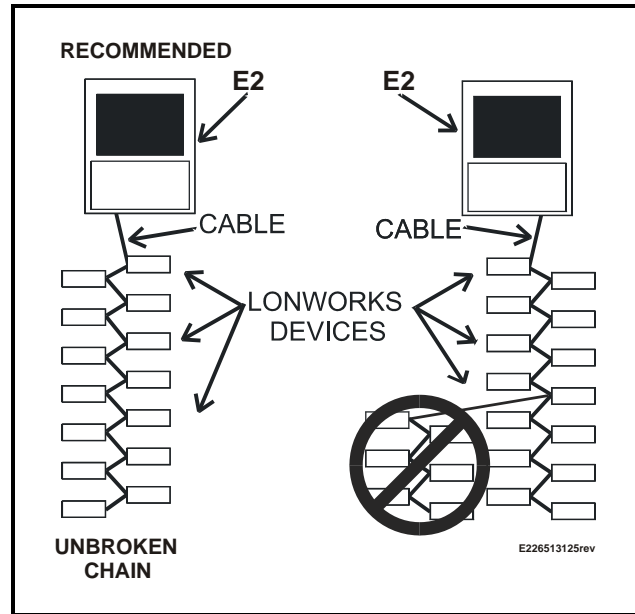

Figure 6-5 - Echelon Wiring - Subnets

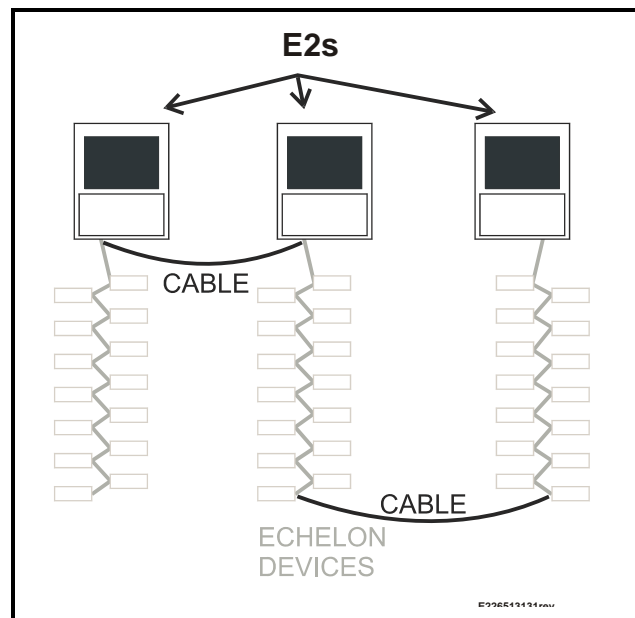

Figure 6-6 - Echelon Wiring, pt. 2

6.2.1. Echelon Network Termination

Echelon networks require the devices on each end of the daisy chain to be terminated with a 105-ohm resistor across the signal-carrying leads. Most CPC-manufactured Echelon devices have on-board termination jumpers that, when set to the “terminated” position, provide the required termination resistance (refer to the device’s own installation documentation). If the device does not have termination jumpers, CPC offers an Echelon termination block (P/N 535-2715) that may be wired in series right before the end device (see **Figure 6-7**) or at the end of an Echelon network run (necessary for TD3 installations) (**Figure 6-8**). The termination block provides the necessary 105-ohm resistance for network termination.

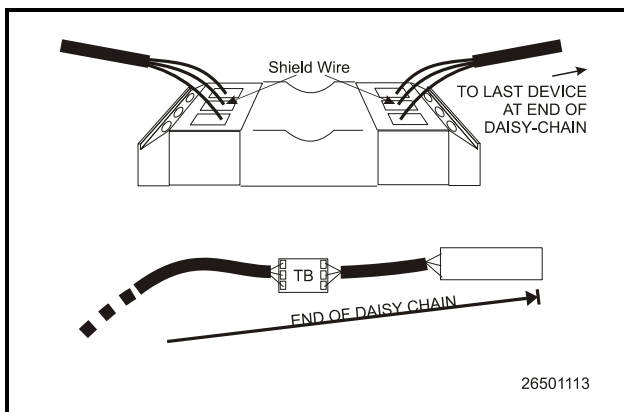

Figure 6-7 - Echelon Termination Block (P/N 535-2715)

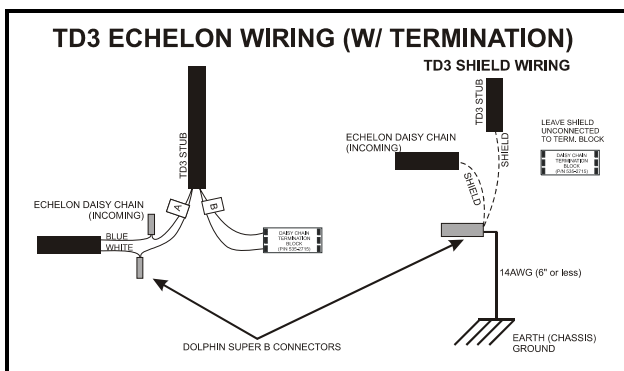

Figure 6-8 - Termination Block Usage With TD3s

7 Cable and Device Grounding

Proper grounding is an essential part of reducing network noise. Failure to properly ground power and network wiring is one of the most common causes of critical noise problems. Follow these guidelines when installing RS485/MODBUS and Echelon networks, and refer to them when troubleshooting problematic installations to ensure the grounding is correct.

7.1. General Grounding Guidelines

A good ground wire provides a low-DC-resistance path between the cable's or device's ground connection and the earth ground. However, because of the presence of high frequency AC noise, the ground wire itself must also be limited in length, or else it may become an "antenna" and add noise to the network.

7.1.1. Ground Wire Specifications

The length of all ground wires should be kept to **6 inches (15.3 cm) or less**. Use a 14AWG stranded wire or larger.

7.1.2. Ground Source Specifications

The best "good" earth ground sources to use are listed below, in priority order:

- A large metal panel or plate that is connected to a good electrical ground. A panel or plate that is at least 3 feet by 3 feet (0.9 m by 0.9 m) is desirable.
- Earth grounded steel rack.

If none of these types of earth ground sources are available, as a last resort use one of the following types of earth grounds. These are not ideal and should not be used unless absolutely necessary:

- Metal electrical conduit, connected to an earth ground
- Water pipes (metal, assuming there are no plastic sections).

- Electrical system earth ground.

Note: If grounding against a metal plate or panel that is coated or painted, scrape away the coating to expose the bare metal before making the ground attachment, and use a tooth washer.

7.2. Power Input and RS485/MODBUS Grounding

For E2s networked with RS485 I/O Network devices, such as MultiFlex, or MODBUS devices such as Control Link RSCs or CDs, grounding must be done on both the **power inputs** and the **network connector terminals** for each device in the network (including the E2).

7.2.1. E2

7.2.1.1. Grounding the EARTH GROUND Terminal

The Power Interface Board (PIB) on the E2 has an earth ground connector (J3) next to the power connector on the lower right corner of the board. Connect this connector to an earth ground source using a ground wire at least 14AWG and no longer than six inches. To further ensure the ground path is complete:

- Scrape away any paint or coating (if grounding to a panel or chassis)
- Use the shortest piece of 14AWG stranded wire available.
- If grounding to the door of a panel, make a second 14AWG wire connection between the panel door and the chassis (do not rely on the hinges of the panel to provide ground connection to the chassis).

7.2.1.2. Grounding the RS485 Network Cable

Provided all power connectors are properly grounded, the shield wire for all cables connecting to an E2 network connector may be connected to the center (0V) terminal of the network connector.

If the network is experiencing problems with EMI or is known to be in a high-noise environment, follow the EMI-resistant wiring guidelines for grounding the shield wire outside the E2 enclosure (**Section 7.3.1.**, *Ground the Shield Outside of the E2*).

7.2.2. RS485 I/O and MODBUS Devices (except Control Link)

7.2.2.1. Grounding the Power Connector Terminal

Each RS485 I/O and MODBUS device, including both devices that are powered by center-tapped transformers and devices powered by non-center-tapped transformers, must have the 0V terminal of the power connector connected to a separate earth ground. “Separate” earth ground means you may NOT wire the 0V connectors of multiple boards in series and ground at one point. Each 0V terminal must be earth grounded separately. Connect each 0V terminal for all networked devices earth grounds, using ground wires at least 14AWG and no longer than six inches.

7.2.2.2. Grounding the Network Cable

The shield wires of the network cable are normally connected to the center (0V) terminal of the RS485 I/O connector. Provided the power inputs are properly grounded, you do not need to connect the center (0V) terminals to separate earth grounds, since the center pins of both the power and network connectors are common on the board.

If the network is experiencing problems with EMI or is known to be in a high-noise environment, follow the EMI-resistant wiring guidelines for grounding the shield wire outside the E2 enclosure (**Section 7.3.1.**, *Ground the Shield Outside of the E2*).

7.2.3. Control Link Modules

The Control Link Module does not have a ground terminal on its power output. The only ground connection on the Control Link that needs to be earth grounded is the “Common” terminal on the top input block (see **Figure 7-1**). The ground wire

should be at least 14AWG stranded, no longer than six inches, and should be routed away from all high-voltage wiring leading from the power input and the relay outputs.

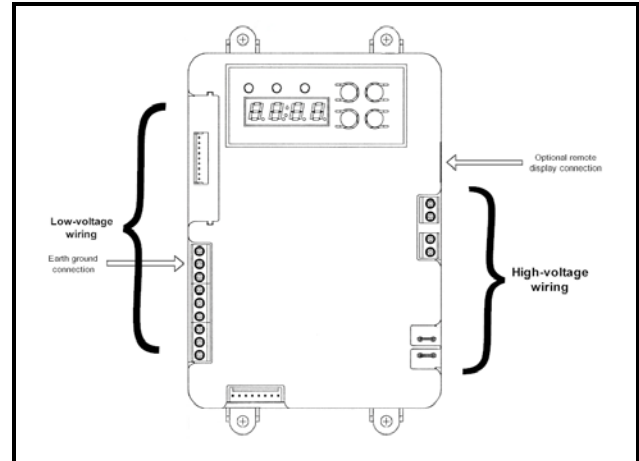

Figure 7-1 - Earth Ground Connection Location

7.3. EMI-Resistant RS485 Network Grounding Practices

If you are experiencing network problems that might be related to noise, it is best to eliminate the noise path at the device itself and through earth grounding prevent the noise from traveling through the cable into the E2.

Begin by identifying potential sources of noise, and identifying what I/O or MODBUS devices are near the noise source or connected (by cable) to the noise source (refer to **Section 1.2.** and **Section 2** for common noise sources). For example, a MultiFlex 168AO connected to a VSD drive by analog output cable would be a possible source of harmful noise.

For I/O and MODBUS devices connected to or near high-noise devices:

1. Ensure the power connector is connected to a good earth ground as per **Section 7.2.2.1.**
2. Remove the shield wire(s) connected to the 0V (center terminal) of the RS485 network connector (leave nothing connected to the 0V terminal).
3. Connect the network cable shield wire to the same earth ground the power connector is connected to. For

example, if the power connector is grounded against the panel chassis, ground the network wires to the same chassis. Keep the total exposed length of the shield wire as short as possible (three inches ideal length). For breaks in the middle of the segment, twist the two shield wire ends together, and connect them both to the same earth grounded point.

4. At the E2, remove the network cable shield wire(s) from the 0V (center terminal) of the RS485 network connector (leave nothing connected to the 0V terminal).
5. Strip the cable jacket and shielding at the point where the cable(s) enter the E2 enclosure. Connect the wire(s) to the same earth ground the “GROUND” connector is connected to. For example, if the E2’s “GROUND” power connector is grounded against the panel chassis, ground the network wires to the same chassis. If the E2 is not at the end of the network segment, the shield wire of both cable segments leading to the I/O connector must be earth grounded outside

the E2 enclosure. Twist the two shield wires together and connect them both to the same earth grounded point.

Do **NOT** connect network shield wires to the GROUND connector on the E2 PIB! I/O and MODBUS network wires must be grounded separately from the EARTH GROUND connector as shown in *Figure 7-2*.

Steps 2 and 3 may be followed for any and all network devices on an RS485 I/O or MODBUS network segment. If a source of noise cannot be found, or if the network in general is exposed to high EMI, it is recommended all network shield wires be disconnected from the 0V terminals and earth grounded near the device. *Figure 7-2* shows an example of an EMI-resistant E2 networked with MultiFlex boards, with each device grounded properly.

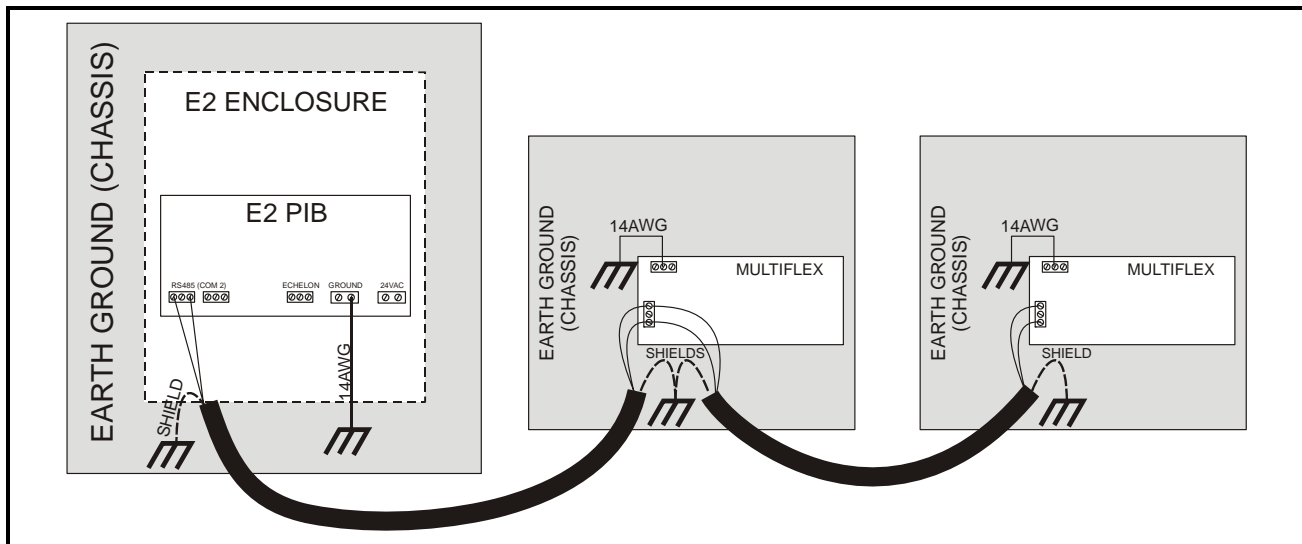

Figure 7-2 - RS485 Network Segment Grounding Practices (E2 and MultiFlex)

7.4. VSD Drive Grounding Practices

Due to noise concerns, it is recommended that all I/O devices networked or connected to a VSD drive follow the guidelines for EMI-resistant network device grounding (see **Section 7.3**).

For Control Techniques SK3500 series VSDs and Unidrives, you must connect the 0V terminal of the drive to the earth grounded chassis of the drive with a 14AWG stranded wire. See Control Techniques Technical Notification T080101 (included for your convenience at the end of this document).

For all other VSD types, refer to the manufacturers’ instructions before grounding the 0V terminal.

7.4.1. Analog Output Cable Grounding

If using a MultiFlex analog output or 4AO board to drive a Control Techniques VSD, you **MUST** use shielded cable between the analog point and the VSD drive speed input. Refer to **Section 4.2.** for specified cable types.

On the end of the analog output cable connected to the VSD input, connect the shield wire to an earth ground. On the I/O device end, clip the shield wire at the point of exposure - do **NOT** connect this end of the shield wire to a terminal on the I/O device or to an earth ground.

Figure 7-3 shows proper grounding for a MultiFlex I/O board and analog output cabling for a device connected to a VSD.

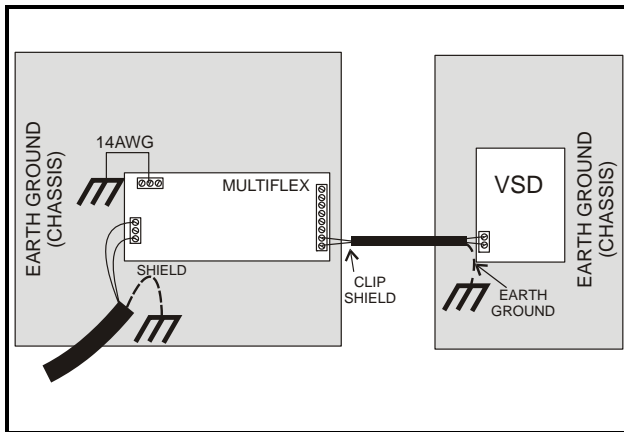

Figure 7-3 - MultiFlex and AO Cable Grounding

7.5. Echelon Cable Grounding

The shield wires for Echelon cable should be connected to the 0V (center pin) of each Echelon network connector. At each node and at each break in the shield, connect the 0V terminals to earth ground. Use 16AWG or 18AWG wire for the 3.81mm Echelon connectors and 14AWG or greater for the 5mm Echelon connectors, and limit the ground wire length to six inches or less.

At the E2, it is recommended the shield wire be connected to a separate earth ground outside of the E2 enclosure instead of connected to the 0V terminal on the E2's Echelon connector.

7.5.1. EMI-Resistant Echelon Network Grounding (For High-EMI Environments)

If the Echelon network must be in contact with noise-generating devices or be installed in a high-EMI environment, the same practices used for grounding RS485 networks may be used to ground Echelon networks. Refer to **Section 7.3., EMI-Resistant RS485 Network Grounding Practices** and follow the same practices for Echelon shield grounding as are shown in this section for RS485 shield grounding.

Title:	Commander SK Size 3 Earth Leakage Current		
Product:	Commander SK	Issue Date:	14-January-2008
Variant:	N/A	Date Codes:	
Category:	General	Manuals affected:	Yes
Issued By:	Dominic Sim	Priority:	Normal

SUMMARY

It has been highlighted that not all users are following the advice given in the Commander SK manuals, with respect to hazards of unrestricted access to the control circuits, if they are not earthed/grounded.

Failure to comply with this advice may result in an electric shock.

MORE INFORMATION

There is a voltage present between 0V and ground/earth, which is due to capacitive coupling between the power and control circuits in the inverter.

The stray capacitance between the power and control circuits results in a high frequency leakage current flowing (when the drive is running). The current flow is dependant on the level of capacitance present. Note that due to the high frequency content, it cannot be measured accurately by a DVM.

The size 3 has a relatively high capacitance compared to size 2 and the current can cause a painful shock, which is not directly hazardous, but could lead to an accident.

The leakage current present on the Commander SK size 3 can cause interference with the Serial Communications on the drive, due the leakage current being present on the Serial Communications 0V connection. Therefore contact with exposed communication cable connections should be avoided.

RESOLUTION

To eliminate the leakage current problem, the control 0V should be connected to earth/ground at the drive. This can be achieved by:

1. Connecting the 0V directly to the triangular grounding bracket supplied with the drive.
2. Connecting the 0V directly to earth/ground using the M5 earth connection as in Figure 1.

Figure 1

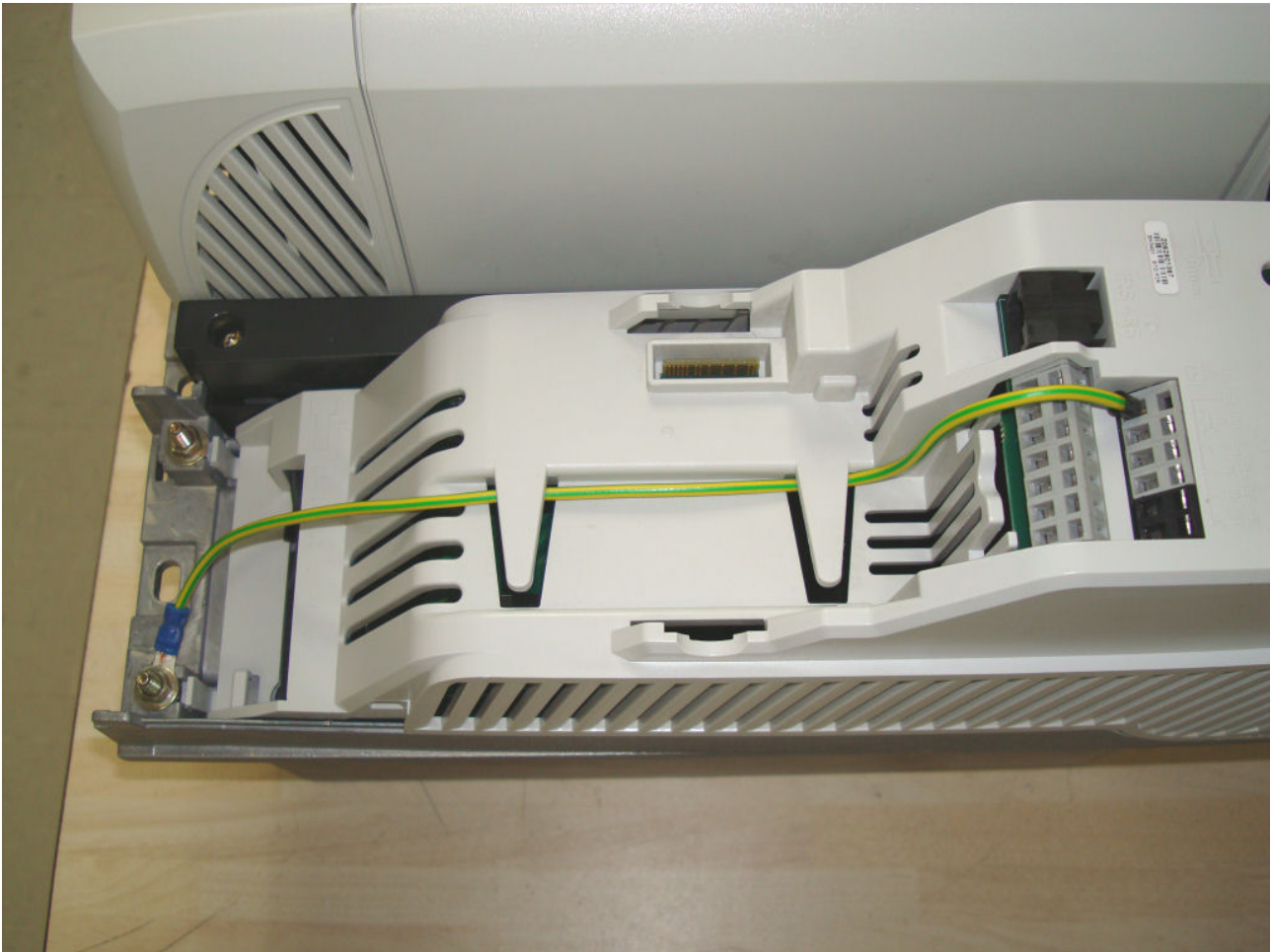

If it is necessary for the 0V to remain floating with respect to earth, such as when a 4-20mA reference is being used, then this connection can be achieved by using a capacitor of 15nF or higher (600Vdc). It should be noted that there is only single isolation, therefore the necessary access protection should be implemented.

MANUAL UPDATE

The product manuals will be updated during the next up issue.