

Control Link ACC Dew Point Sensor

In order for the Control Link ACC to function properly, the dewpoint sensor (P/N 814-6115) must be placed where it can measure the dewpoint of the air outside the case. Mount the sensor underneath the top side of the case in the area just above the top of the case doors (Figure 1 - Sensor Placement).

A 0.25" x 0.25" (6.35 mm x 6.35 mm) notch in the edge of the metal frame behind the sensor may be required for the wires connecting the dewpoint sensor to the Control Link ACC. **DO NOT let any RTV sealants touch the sensor element, and keep the sensor element as far as possible from RTV sealed areas.**

Do NOT mount the dewpoint sensor near the bottom of the case or any place where cold air from the case can affect the sensor reading. Avoid mounting the sensor in an area with excessive water spray or moisture, extremely dirty environments, near heat sources, or in the direct path of HVAC returns. Secure the sensor to the mounting location with the two included screws

(P/N 031-6005) as shown in Figure 2 - Sensor Dimensions. Copeland recommends using pilot holes for the screws. Tighten screws just enough to secure sensor without warping the sensor housing.

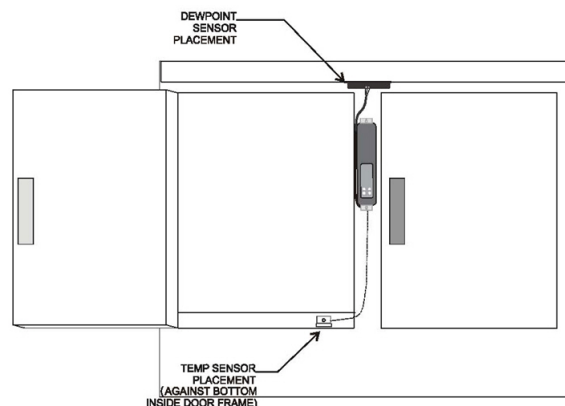

Figure 1 - Sensor Placement

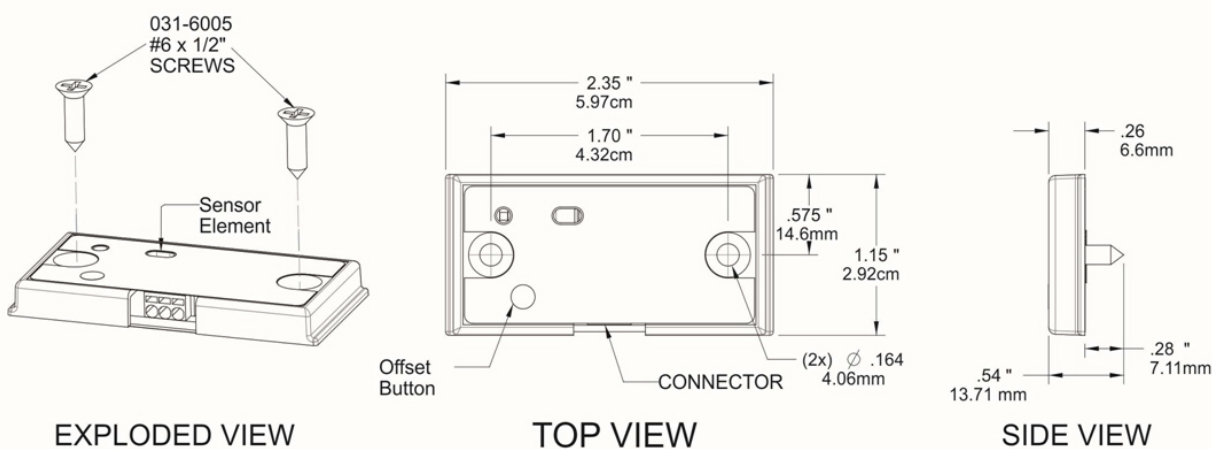

Figure 2 - Sensor Dimensions

Dewpoint Sensor Wiring

The dewpoint sensor cable can be 20-24 AWG range. Copeland recommends Belden# 8711 P/N 135-8711 22AWG cable or equivalent (not supplied). To install or remove wires from the dewpoint sensor connector, insert a small screwdriver, such as a Phoenix Contact P/N 0116993 PTSM Screwdriver (not supplied), into the top rectangular slots on the connector (above the wire terminals) until it stops; insert or remove wires as shown in [Figure 3 - Dewpoint Sensor Connector - ACC View](#). Insert the three (3) wires on the other end of the cable to the matching 3-pin connector of the low voltage end of Control Link ACC by first pressing in the orange tabs above the terminals with the small screwdriver. Ensure the wire colors match for the Power, Data and Ground terminals on dewpoint Sensor and the Control Link ACC.

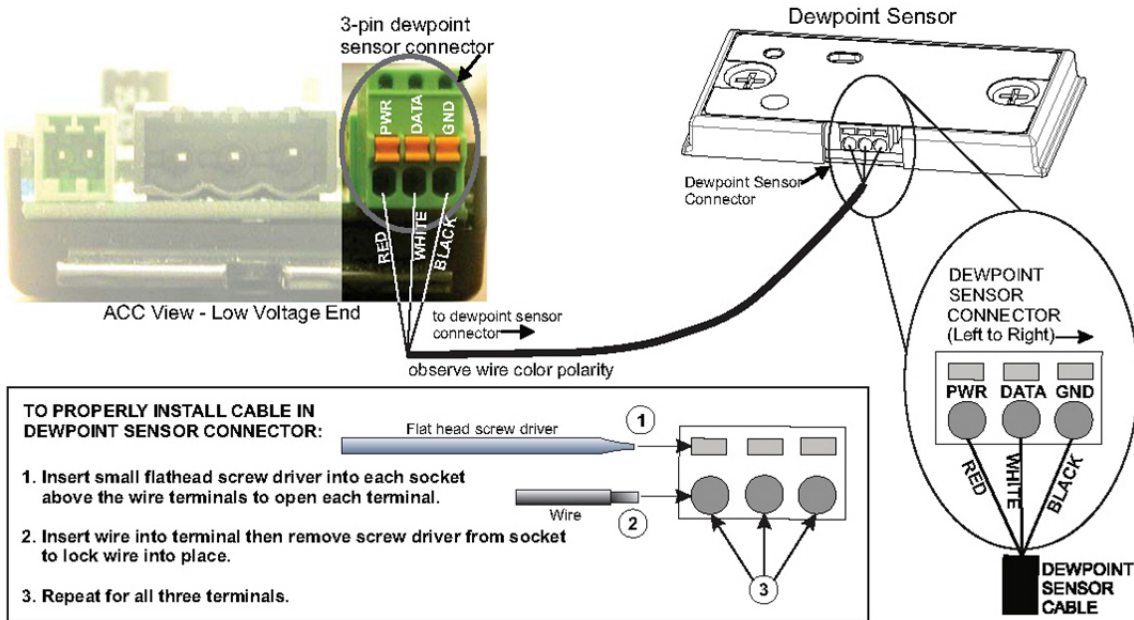

Figure 3 - Dewpoint Sensor Connector - ACC View

Visit our website at copeland.com/en-us/products/controls-monitoring-systems for the latest technical documentation and updates. For Technical Support call 833-409-7505 or email ColdChain.TechnicalServices@Copeland.com