

**I
N
S
T
R
U
C
T
I
O
N

M
A
N
U
A
L**

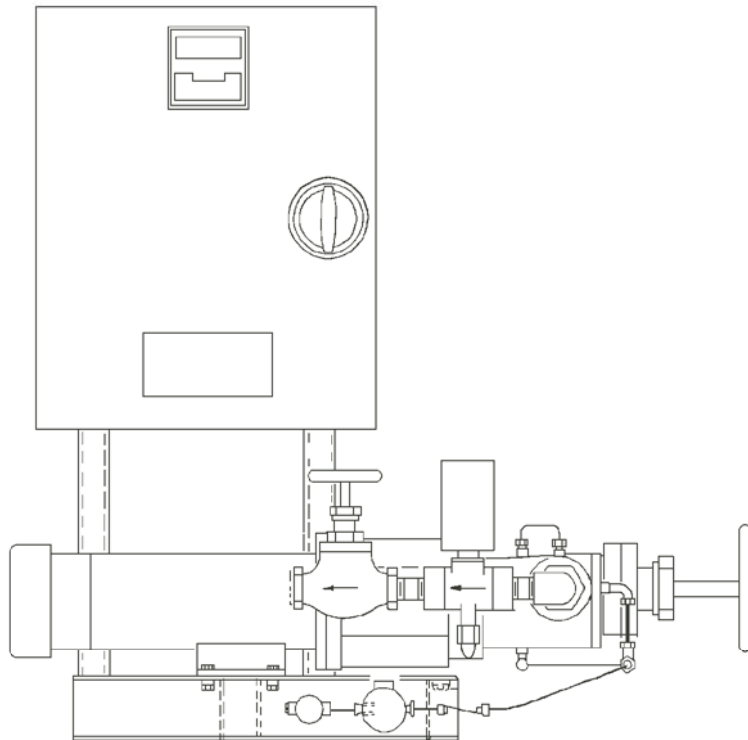

V-Plus[®]

Liquid Injection Oil Cooling System

Part # 35391X
Price \$ 25.00

VILTER MANUFACTURING CORPORATION

V-PLUS® PUMPED LIQUID UNITARY SYSTEM

TABLE OF CONTENTS

<u>PAGE</u>	
1	PRECAUTIONS, SAFETY PRACTICES, FIRST AID, AND PREVENTIVE MAINTENANCE MEASURES
4	INTRODUCTION
4	THEORY
4	GENERAL INFORMATION
11	INSTALLATION INSTRUCTIONS
11	Introduction
11	Cleanliness
12	LOCATION OF V-PLUS COMPONENTS
14	GAS PURGING FLOAT VALVE
16	SPECIFICATIONS
17	BASIC FUNCTION OF COMPONENTS
17	V-PLUS Pump
17	Pump Motor
17	Lubrication Line Components
17	Pump Inlet Piping Components
18	Pump Outlet Piping Components
18	Liquid Injector Nozzle
18	Gas Purging Valve
19	LIMITATIONS
20	SPEED CONTROL AND TEMPERATURE CONTROLLER STARTUP INSTRUCTIONS

VILTER MANUFACTURING CORPORATION

V-PLUS® PUMPED LIQUID UNITARY SYSTEM

TABLES AND ILLUSTRATIONS

<u>PAGE</u>	<u>FIGURE</u>	
5	1	TYPICAL V-PLUS SYSTEM – DESIGNED AS A RETROFIT (FRONT VIEW)
6	2	TYPICAL V-PLUS SYSTEM – DESIGNED AS A RETROFIT (TOP VIEW)
7	3	TYPICAL V-PLUS SYSTEM – DESIGNED AS A RETROFIT (SIDE VIEW)
12	4	V-PLUS IDEAL FIELD INSTALLATION
15	5	GAS PURGING FLOAT VALVE LOCATION
20	6	SETTINGS FOR V-PLUS
21	7	DART SPEED CONTROL
21	8	CLOSE-UP OF DART CONTROL SHOWING POTENTIOMETERS
22	9	TRIMPOT SETTING CHART
23	10	PUMP ROTATION DETAILS
24	11	CONTROL PANEL ASSEMBLY – V-PLUS 1HP
25	12	WIRING DIAGRAM – V-PLUS
26	13	CONTROL PANEL ASSEMBLY – V-PLUS 2HP
27	14	WIRING DIAGRAM – V-PLUS w/2HP MOTOR

<u>PAGE</u>	<u>TABLE</u>	
8	1	REPLACEMENT PARTS LIST FOR FIGURES 1 THRU 3 (1HP AND 2HP MOTOR SYSTEMS)
10	2	REPLACEMENT PARTS LIST FOR FIGURES 1 THRU 3 (1/2HP MOTOR SYSTEM)
24	3	REPLACEMENT PARTS LIST FOR FIGURE 11
26	4	REPLACEMENT PARTS LIST FOR FIGURE 13

VILTER MANUFACTURING CORPORATION

V-PLUS® PUMPED LIQUID UNITARY SYSTEM

PRECAUTIONS, SAFETY PRACTICES, FIRST AID, AND PREVENTIVE MAINTENANCE MEASURES

As with any equipment serving a definite purpose, certain safety precautions must be observed and procedures followed when operating the V-PLUS Oil Cooling System.

Only experienced, qualified personnel should install, operate, maintain and service refrigeration equipment. *DO NOT ALLOW UNQUALIFIED PEOPLE TO WORK ON A REFRIGERATION SYSTEM.*

It is impossible to foresee all potentially unsafe conditions. It is the responsibility of the field personnel to anticipate and avoiding any unsafe condition, and to be equipped with the proper tools as well as all necessary safety equipment. These personnel must acquaint themselves with the following safety procedures:

- 1) Never use an open flame in a refrigeration machinery room. Ammonia can form ignitable mixtures with air and oxygen under limited conditions, even though ammonia is difficult to ignite under normal conditions.
- 2) Since ammonia gas is lighter than air, providing adequate ventilation is an effective way to prevent an accumulation of ammonia. However, anhydrous ammonia is not a cumulative poison and has a distinctive pungent odor detectable by most people at low concentrations. Ammonia is self-alarming and serves as its own warning agent, so no one will voluntarily remain in hazardous concentrations.
- 3) Anyone overcome by ammonia refrigerant vapor should be removed immediately from the contaminated atmosphere. Administer artificial respiration and obtain the services of a physician as soon as possible.
- 4) Since ammonia liquid splashes or concentrated ammonia vapor can cause skin burns, the affected area should be washed immediately with large quantities of water. This should be continued for at least 15 minutes, removing all clothing while washing. A physician should be summoned as soon as possible. After washing, apply wet compresses (solution of 2½% of borax and boric acid in distilled water) to affected parts until medical advice is available. If ammo-

VILTER MANUFACTURING CORPORATION

V-PLUS® PUMPED LIQUID UNITARY SYSTEM

nia liquid or vapor gets into the eyes, they should be washed immediately with the above solution, for at least 30 minutes.

- 5) Avoid breathing any liquid refrigerant mist into the lungs. It can be fatal. Always wear goggles when opening any part of a refrigerating system.
- 6) A Daily Operating Log should be maintained so any unusual conditions can be immediately observed and promptly corrected. The log should include operating temperatures and pressures, startup and shutdown, pumpdown operations, and the results of any work or tests performed.
- 7) Machinery guards should always be properly installed before operating machinery. Be sure they are in compliance with all local applicable codes.
- 8) Protect piping, valve stems, gauge glasses and all vulnerable items containing refrigerant from fracturing if struck by vehicles or other moving parts. Guard rails, bumper posts or other means should be provided.
- 9) Fire extinguishers should be available in all machinery rooms.
- 10) Gas masks, for use with refrigerants, should be available and kept clean and in good condition for emergency use.
- 11) All safety tags with notations such as “Danger”, “Hands Off”, “Do Not Operate”, and “Do Not Throw Switch” should be attached to valves, switches, starters and other strategic locations when making repairs.
- 12) A loose valve bonnet or packing gland nut can release sufficient refrigerant to cause personal injury. Always watch screwed stop valve bonnets and packing gland nuts when opening a valve to make sure they do not screw out with the stem.

The refrigeration equipment operator should be familiar with the following publications:

1. The Safety Code for Mechanical Refrigeration, ANSI/ASHRAE 15
2. Refrigeration Piping Code, ANSI B31.5

VILTER MANUFACTURING CORPORATION

V-PLUS® PUMPED LIQUID UNITARY SYSTEM

Both of these Codes are updated on a 4 or 5-year cycle. A year (date) follows the standard number. This is the date of last issue. Both of these publications must be ordered.

The first publication (ANSI/ASHRAE Standard 15) may be obtained from:

ASHRAE
1791 Tullie Circle NE
Atlanta, GA 30329

The second publication (ANSI Standard B31.5) may be obtained from:

American National Standards Institute
1819 L Street NW
Washington, DC 20036

The refrigeration equipment operator should also be familiar with the "IIAR Minimum Safety Criteria For A Safe Ammonia Refrigeration System" Bulletin No. 109.

VILTER MANUFACTURING CORPORATION

V-PLUS® PUMPED LIQUID UNITARY SYSTEM

INTRODUCTION

THEORY

The V-PLUS (Vilter Pumped Liquid Uitary System) oil cooling system cools the screw compressor oil by drawing liquid refrigerant from the receiver and pumping it directly into the discharge line of the screw compressor. This liquid refrigerant will then boil at the same pressure as the discharge pressure of the screw compressor and cool the screw compressor oil. Both the discharge gas and the oil leaving the compressor are being cooled to the same temperature. This temperature will then become the system's oil temperature.

A conventional liquid injection unit injects liquid into the compressor itself at some point in the compression cycle. This conventional method of oil cooling requires more horsepower to cool oil than the V-PLUS system, which vaporizes liquid refrigerant in the discharge line of the compressor. The V-PLUS system does not need the additional horsepower to recompress the vapor that a conventional system needs.

GENERAL INFORMATION

The V-PLUS system, as designed for new screw compressor units, is mounted on the screw compressor unit itself. It has the same parts as the V-PLUS unit designed as a retrofit except for the Control Panel Assembly and base. On new screw compressor units, the pump motor is factory wired to the main Control Panel Assembly already mounted on the unit.

The V-PLUS system also can be used as a retrofit to accommodate existing units now in the field. Several items are shipped loose with the V-PLUS retrofit unit itself in Kit form for field mounting to the existing screw compressor unit.

For information on retrofit units, please contact the Vilter home office.

VILTER MANUFACTURING CORPORATION
V-PLUS® PUMPED LIQUID UNITARY SYSTEM

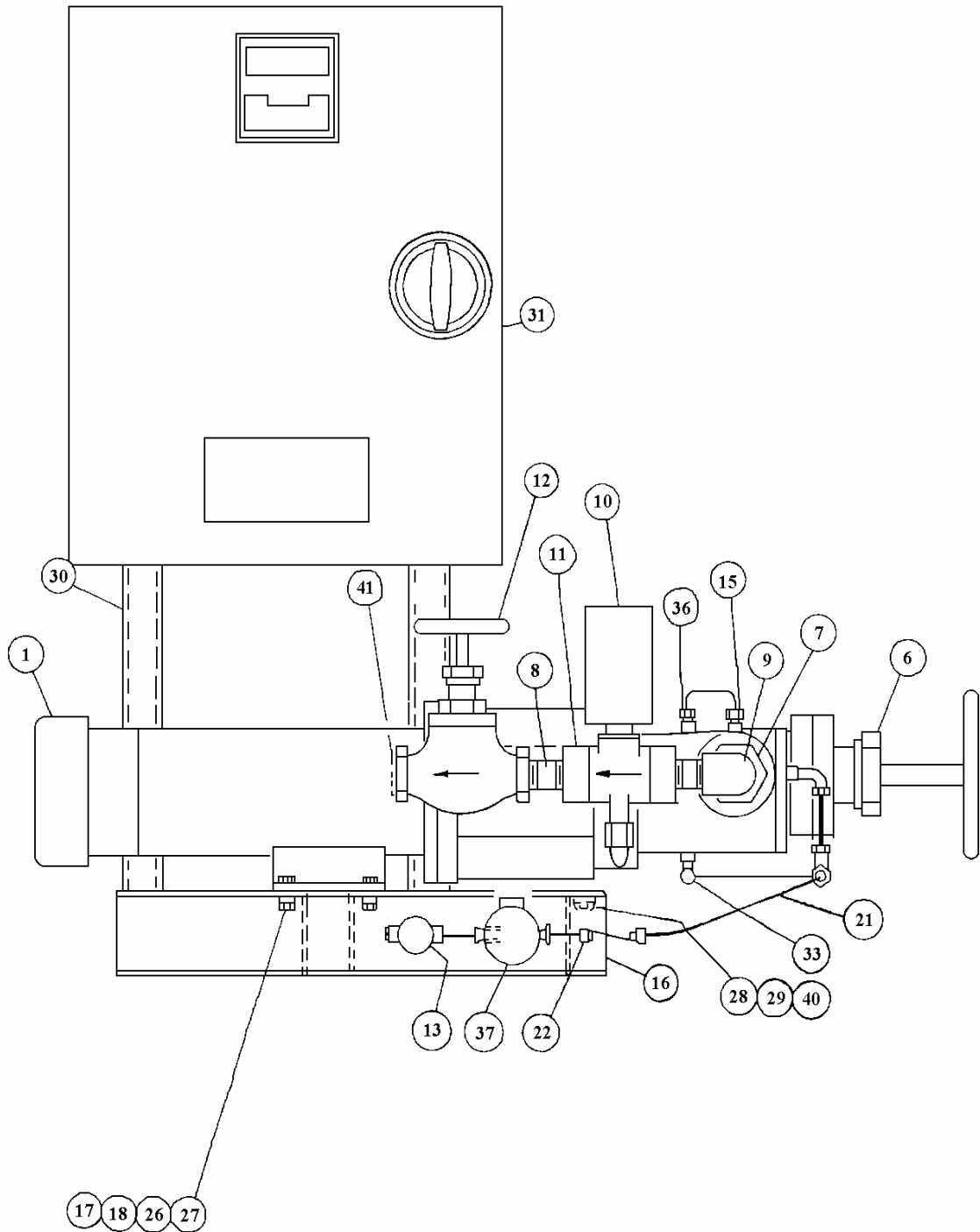

FIGURE 1. TYPICAL V-PLUS SYSTEM – DESIGNED AS A RETROFIT FRONT VIEW

VILTER MANUFACTURING CORPORATION
V-PLUS® PUMPED LIQUID UNITARY SYSTEM

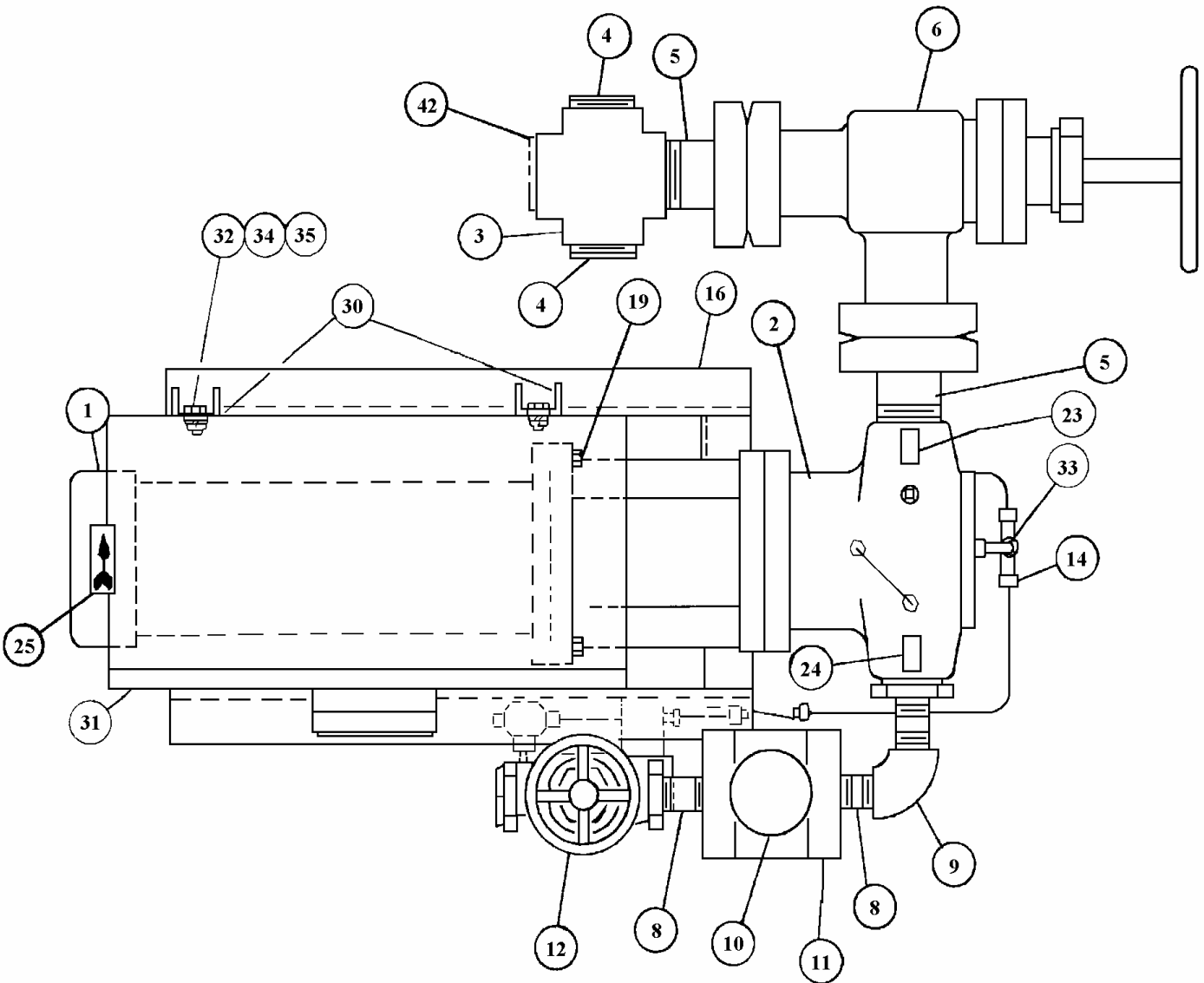

FIGURE 2. TYPICAL V-PLUS SYSTEM – DESIGNED AS A RETROFIT
TOP VIEW

VILTER MANUFACTURING CORPORATION
V-PLUS® PUMPED LIQUID UNITARY SYSTEM

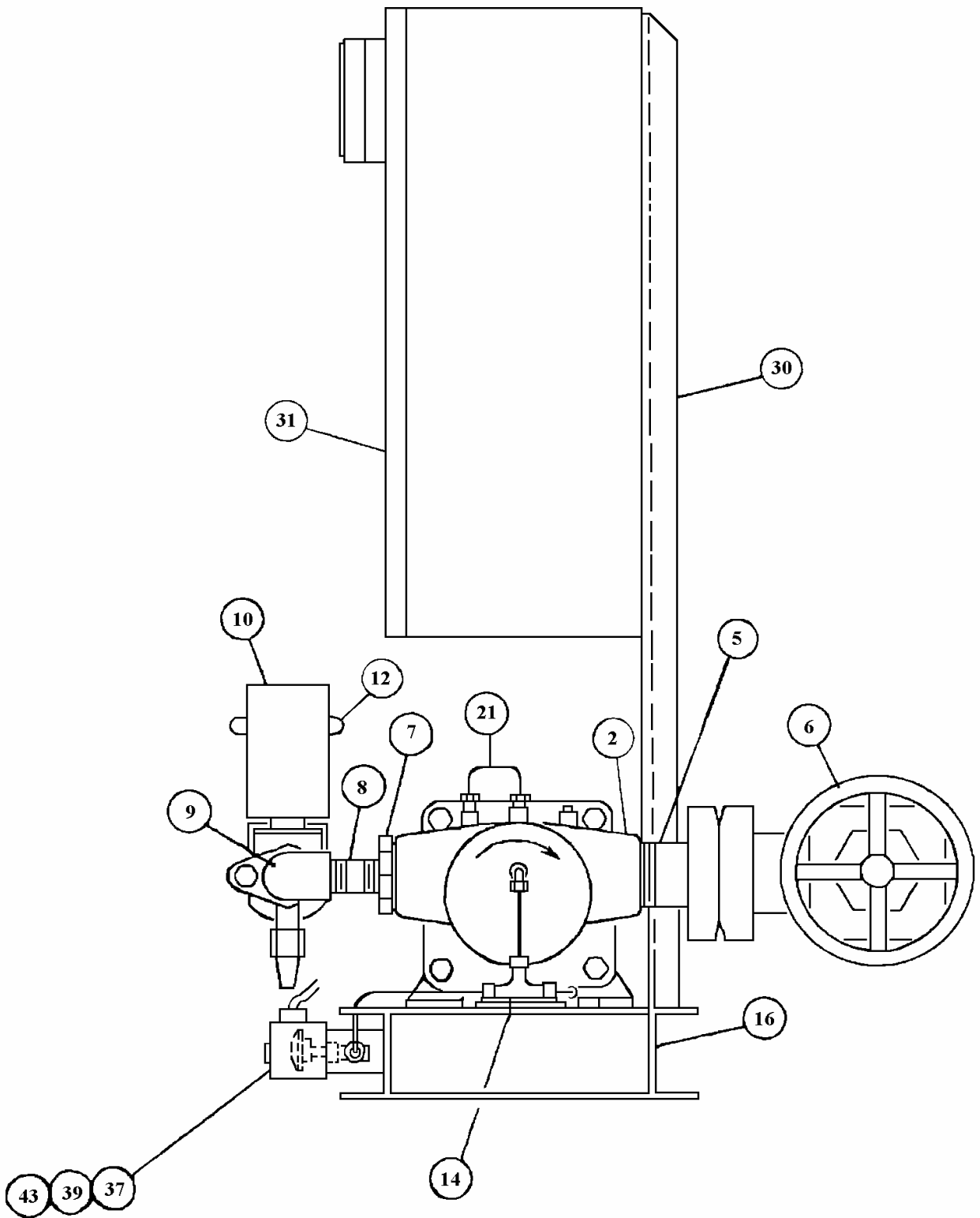

FIGURE 3. TYPICAL V-PLUS SYSTEM – DESIGNED AS A RETROFIT
SIDE VIEW

VILTER MANUFACTURING CORPORATION

V-PLUS® PUMPED LIQUID UNITARY SYSTEM

TABLE 1. REPLACEMENT PARTS LIST FOR FIGURES 1 THRU 3 (1HP and 2HP Motor Systems)

Item Number	Description	Quantity Required	Part Number
1	Motor, 1 H.P., 90 V.D.C., 1725 RPM, 56C Frame	1	2494A
1	Motor, 2 H.P., 200 V.D.C., 1725 RPM, TEFC, 184C Frame	1	2494B
2	Pump, Heavy Duty Complete with Drive Unit (1 H.P. & 2 H.P. 20 GPM)	1	2501A
2	Pump, Heavy Duty Complete with Drive Unit (2 H.P.)	1	2501D
2A	Seal for Pump 2501A	1	2402SS
2B	Coupling, Drive for 1 H.P., 56C Frame Motor	1	2913C
2B	Coupling, Drive for 2 H.P., 184C Frame Motor	1	2913E
3	Cross, 1½" Forged Screwed Steel	1	1100H
4	Sight Glass, 1½" Clear	2	1484C
5	Pipe, 1½" Pickled Sch. Threaded One End	2	41683C
6	Valve, 1½" Flanged Ammonia Angle w/S.W. Flanges, Bolts and Gaskets	1	A14024W
7	Bushing, 1½" MPT x ¾" FPT Hex	1	1102E
8	Nipple, ¾" Sch. 80 Pipe x 2½"	3	13193C
9	Elbow, ¾" Screwed End 90°	1	1097E
10	Valve, Ammonia Solenoid 115 VAC, 50/60 Hz	1	1227EA
10A	Coil for Valve 1227EA	1	1377A *
11	Flanges, ¾" FPT 2-Bolt Oval w/Bolts and Gaskets	1	2408U
12	Valve, ¾" Screwed End Ammonia Globe	1	A15377A
13	Valve, 2-Way with ¼" O.D. connections	1	2029A
14	Tee, ¼" O.D. Union	1	13239C
15	Connector, ¼" O.D. x ¼" M.P.T. x 1½" Male Compression	1	13229D
16	Base (1 H.P.)	1	A34757A
16	Base (2 H.P. 20 GPM)	1	A34757B
16	Base (2 H.P. 30 GPM)	1	A34757C
17	Screw, 5/16" - 18NCx1¼" Hex Head Cap (1 H.P.)	4	1047Y
17	Screw, 3/8" x 1¼" Hex Head Cap (2 H.P.)	4	13149D
18	Nut, 5/16" - 18NC Heavy Hex (1 H.P.)	4	1726B
18	Nut, 3/8" - 16NC Heavy Hex (2 H.P.)	4	1726C
19	Screw, 3/8" - 16NC-2 x 1¼" Hex Head Cap.	4	2487A
21	Tubing, 3 Lineal Feet - ¼" O.D. Steel	1	S1589A
22	Valve, In-Line Check with ¼" Connections	1	2493A
23	Decal, "IN"	1	2461B
24	Decal, "OUT"	1	2461C
25	Decal, "FLOW DIRECTION ARROW"	1	2461D
26	Washer, 5/16" Beveled (1 H.P.)	4	13311H
26	Washer, 3/8" Beveled (2 H.P.)	4	13311A
27	Washer, ¼" Flat Black (1 H.P.)	4	13265D
27	Washer, 3/8" Flat Black (2 H.P.)	4	13265E
28	Shim, ½" x 1/16" Pump (1 H.P.)	1	17330A
28	Shim, ½" x 1/16" Pump (2 H.P.)	1	17330B
29	Washer, ½" Beveled	1	13265G
30	Channel, 2" x 1" x 3/16" x 2 Ft. Lg.	2	2552B
31	Control Panel Assembly	1	**
32	Screw, ¼" - 20UNC-2A x ¾" Hex Head Cap	4	2796AE

NOTES: * Recommended Spare Part.

** Refer to Pages 23 thru 25 for information on the Control Panel Assembly

VILTER MANUFACTURING CORPORATION

V-PLUS® PUMPED LIQUID UNITARY SYSTEM

TABLE 1. REPLACEMENT PARTS LIST FOR FIGURES 1 THRU 3 (cont'd)

Item Number	Description	Quantity Required	Part Number
33	Elbow, 1/4" O.D. x 1/8" M.P.T. 90°	2	13375C
34	Nut, 1/4" – 20NC-2B Heavy Hex	4	1726A
35	Lockwasher, 1/4" Carbon Steel	4	13165B
36	Connector, 1/4" O.D. x 1/8" M.P.T. x 1 5/16" Male Compression	3	13229C
37	Valve, Two-Way Ammonia Solenoid 150V, 60Hz	1	2012A
37A	Coil for Valve 2012A	1	2012AA *
39	Screw, No. 10 – 32NF x 5/8" Round Head Zinc Machine	2	1332E
40	Screw, 1/2" – 13NC-2 x 1 1/2" Hex Head Cap	1	2796E
41	Caplug, 3/4"	1	2456DA
42	Caplug, 1 1/4"	1	2456GC
43	Lockwasher, No. 10 Cadmium Plated	2	2080C
44	Caplug, 1/4"	1	2456AC

NOTES: * Recommended Spare Part.

A. Except where noted in the description column, parts listed apply to all V-PLUS Units.

VILTER MANUFACTURING CORPORATION

V-PLUS® PUMPED LIQUID UNITARY SYSTEM

TABLE 2. REPLACEMENT PARTS LIST FOR FIGURES 1 THRU 3 (1/2HP Motor Systems)

Item Number	Description	Quantity Required	Part Number
1	Motor, 1/2HP, 90VDC, 1750 rpm, 56C Frame	1	2494F
2	Pump, Heavy Duty Complete with Drive Unit	1	2501H
2A	Seal for Pump	1	2501K
2B	Coupling, Drive	1	2913C
3	Cross, 1" Forged Screwed Steel	1	1100F
4	Sight Glass, 1" Clear	2	2366C
5	Pipe, 1" Steel	1.5	S1665F
6	Valve, 1" Flanged	1	A14079C
7	Bushing, 1"MPT x 1/2"FPT Hex	1	1101P
9	Elbow, 1", 90°	1	1117E
10	Valve, Solenoid, 120VAC 60 Hz	1	2650EABBF
10A	Coil for Valve 2650EABBF	1	2650W *
11	Flanges	2	A12475DM
12	Valve, 1/2" Angle	1	A15376A
14	Tee, 1/4" OD Union	1	13376C
15	Connector, 1/4" OD x 1/4" MPT x 1 1/2" Male Companion	1	13229D
17	Screw, 5/16"-18NC x 1 1/4" Hex Head Cap	4	1047X
18	Nut, 5/16"-18NC Heavy Hex	4	1726B
21	Tubing, 3 Lineal Feet – 1/4" OD Steel	1	S1589A
22	Valve, In-Line Check with 1/4" connections	1	2493A
26	Washer, 5/16" Lock	4	13165C
28	Shim, 1/2" x 7/16" Pump	1	17330B
31	Control Panel Assembly	1	**

NOTES:

- A. 1/2HP Motor Systems are not available as retrofit units.
- * Recommended Spare Part.
- ** Refer to Pages 23 thru 25 for information on the Control Panel Assembly

VILTER MANUFACTURING CORPORATION
V-PLUS® PUMPED LIQUID UNITARY SYSTEM
INSTALLATION INSTRUCTIONS

INTRODUCTION

A reasonable amount of care must be taken in the location and installation of a V-PLUS System.

Because the liquid refrigerant pump of the V-PLUS System is supplied with the liquid from the receiver, the pressure drop in the liquid supply line must be kept as low as possible to prevent flash gas formation in the pump section.

The following is a list of steps to take when installing a V-PLUS System that will insure a safe and trouble-free system.

CLEANLINESS

Care must be taken to clean all piping before installation of the V-PLUS System to prevent any dirt, scale, or slag from entering the pump during system operation. A strainer is not supplied with the standard V-PLUS System because a low liquid line pressure drop must be maintained. However, a strainer can be installed in those cases where system cleanliness really presents a problem. Refer to the Home Office for sizing.

VILTER MANUFACTURING CORPORATION
V-PLUS® PUMPED LIQUID UNITARY SYSTEM
LOCATION OF V-PLUS COMPONENTS

See Figure 4 below for the suggested field installation of the V-PLUS unit.

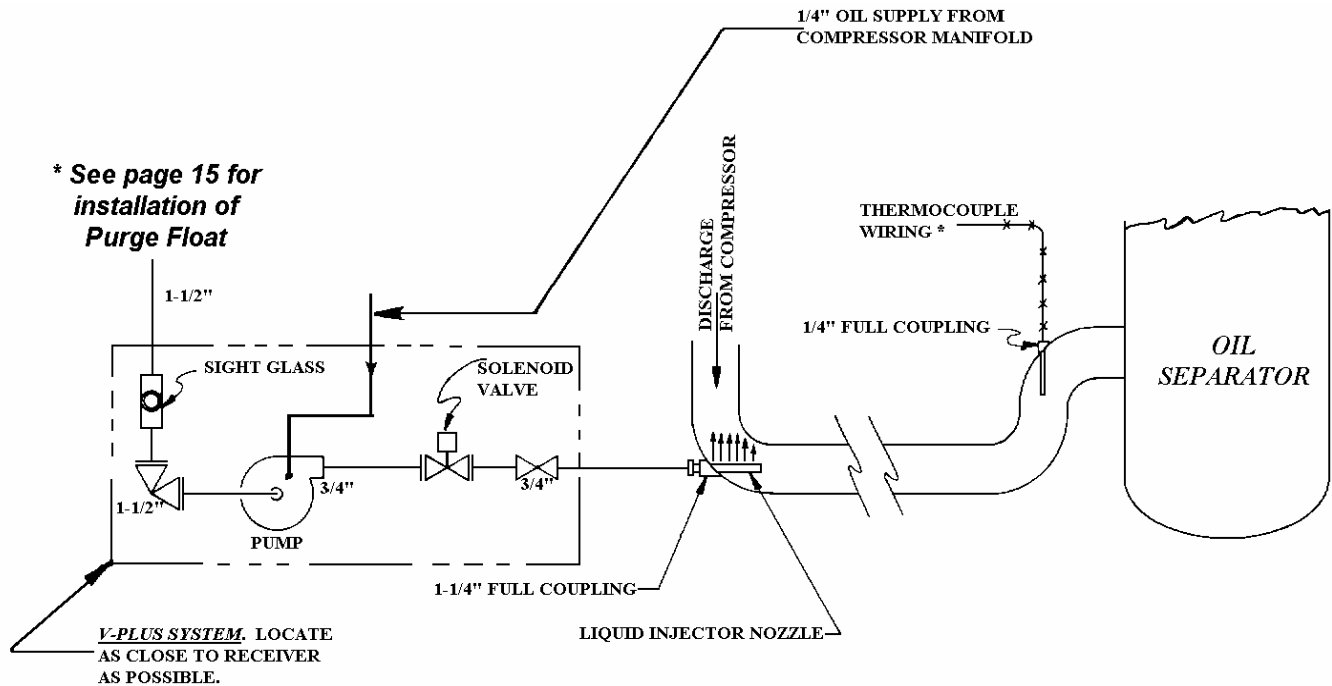

* The thermocouple wiring should also be installed into the Temperature Sensor, which is located in the oil line between the oil separator and oil pump.

FIGURE 4. V-PLUS IDEAL FIELD INSTALLATION

All liquid supply lines to the liquid pump must be 1½" Sch. 80 pipe minimum. There should be as few elbows or bends as possible.

The following five items are shipped loose for field mounting as part of the KT530 Series Kits.

- Two – Temperature Sensor, Part Number 2540B
- One – Ammonia Liquid Injector Nozzle, Part Number A17326B
- Two – ¼" – 3000# Black Coupling, Part Number 13214B
- One – 3000# Black Coupling, Part Number 13214G
- 35 Ft. of Thermocouple Wire, Part Number 2539A

The ¼" Full Coupling, Vilter Part Number 13214G, must be welded into the discharge elbow directly below the screw compressor. The Liquid Injector Nozzle, Vilter Part Number A17326B, screws into this

VILTER MANUFACTURING CORPORATION

V-PLUS® PUMPED LIQUID UNITARY SYSTEM

coupling. The holes in the Injector Nozzle must face upward, so that good mixing of the liquid refrigerant with the discharge gas and oil will result.

One ¼" NPT Half Coupling, Vilter Part Number 13214B, must be welded just before the oil separator in the compressor discharge line. The other ¼" NPT Half Coupling must be welded in the oil line between the Oil Separator and the Oil Pump. A Temperature Sensor, Vilter Part Number 2540B, is installed into each of these couplings. The Thermocouple Wire, Vilter Part Number 2539A, should then be installed into each of these Temperature Sensors and should be long enough to run from the Temperature Sensor to the V-PLUS unit.

VILTER MANUFACTURING CORPORATION
V-PLUS® PUMPED LIQUID UNITARY SYSTEM
GAS PURGING FLOAT VALVE

The Gas Purging Float Valve must be installed at the highest elevation of the liquid supply line. The purpose of this valve is to prevent pump cavitation and loss of cooling by venting any flash gas formed in the liquid supply line. Figure 5 on page 15 shows the location of this valve in two possible piping situations.

The 1 ½" diameter liquid supply line in the bottom drawing of Figure 5 is called a "dedicated" liquid supply line. If it is not possible or practical to use a dedicated liquid supply line as described, the liquid supply line of the V-PLUS can be piped to the main liquid outlet of the plant. This is shown in the top drawing of Figure 5. A Gas Purging float Valve will be required in either case. Generally speaking, any time there is a possibility of trapping refrigerant gas in the liquid supply line to the V-PLUS, a gas purging float valve will be required.

The pressure drop of the liquid through piping and lower pressure created by the pump at its suction inlet could result in the refrigerant flashing at the pump inlet. This could occur if the pressure at the pump suction falls below the equivalent saturation temperature of the liquid.

The liquid pump will cavitate as a result of flash gas created in the liquid supply line and accumulation at the pump suction. Cavitation, in turn, will cause the pump to lose its prim and a loss of oil cooling will occur. Therefore, a certain amount of liquid subcooling is necessary to prevent cavitation.

Generally, 3° to 4° of subcooling will counteract the pressure losses. To stop pressure fluctuations, however, more subcooling is required. **IF LESS THAN 15°F SUBCOOLING IS AVAILABLE, A GAS PURGING FLOAT VALVE IS REQUIRED.**

If this subcooling can't be maintained, a special gas purging float valve must be used. This gas purging float valve also must be used if the location of the pump and the piping arrangements do not meet requirements. This valve will prevent cavitation in either situation. The amount of gas purged to the suction is only the flash gas created by piping pressure drops and pressure flow.

VILTER MANUFACTURING CORPORATION
V-PLUS® PUMPED LIQUID UNITARY SYSTEM

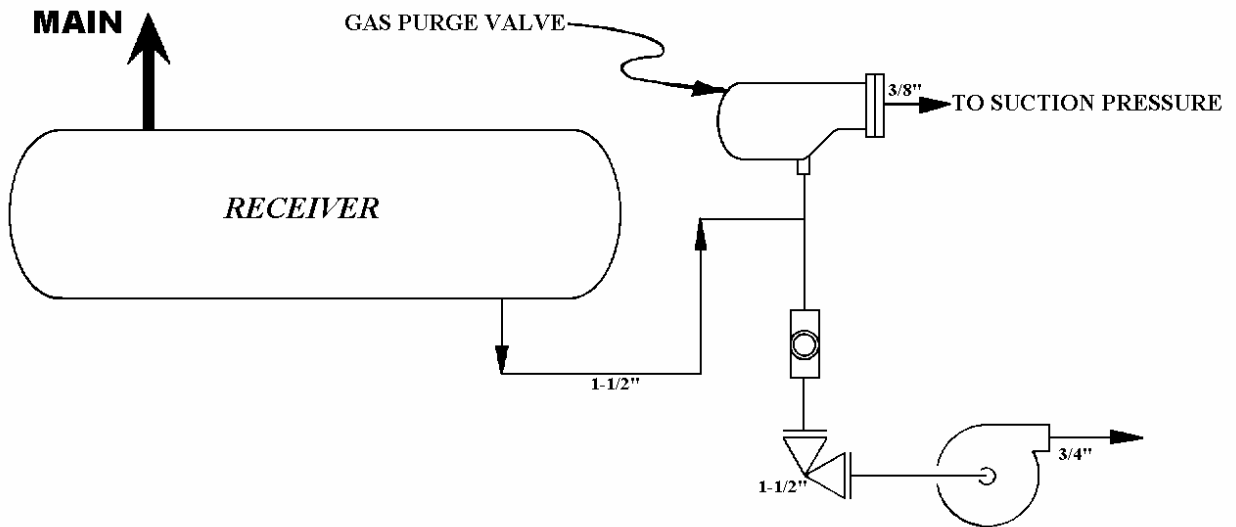
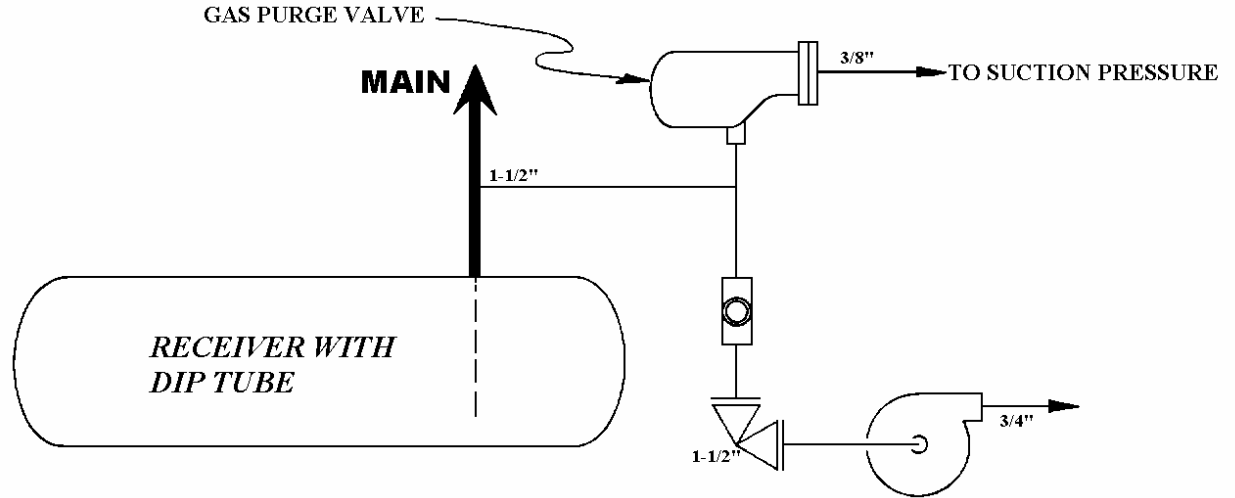

FIGURE 5. GAS PURGING FLOAT VALVE LOCATION

The $\frac{3}{8}$ " bleed line from the float (Vilter Part Number A14077C) should be piped into a suction trap, if possible, otherwise it may be piped into a suction header.

VILTER MANUFACTURING CORPORATION
V-PLUS® PUMPED LIQUID UNITARY SYSTEM
SPECIFICATIONS

The V-PLUS liquid pump, motor and control panel (as furnished on retrofit units) will be described in this section.

1. *Liquid Heavy Duty Pump*

The pump is a positive displacement, internal gear, rotary type pump with compact horizontal mounting. This Heavy Duty Pump includes a combination motor "C" flange and square flange bracket with coupling to connect motor and pump. This pump has an o-ring head, valve gaskets, and mechanical seals as standard construction.

2. *Motor*

The motor used in the V-PLUS system is a DC 1 or 2 horsepower, 1725 RPM motor. It has a TEFC enclosure for continuous duty in a NEMA frame 56C or 184C, respectively. The motor has Class "E" insulation and can be either foot or face mounted, but face mounting is used to accommodate the pump.

3. *Control Panel*

The Control Panel Assembly consists of a motor speed control, a relay, terminals, fuses and a Temperature Indicating Controller. All items listed are mounted within a NEMA 1 enclosure. The control panel assembly itself is mounted on the base of the V-PLUS unit.

VILTER MANUFACTURING CORPORATION
V-PLUS® PUMPED LIQUID UNITARY SYSTEM
BASIC FUNCTION OF COMPONENTS

The V-PLUS oil cooling system cools screw compressor oil by drawing liquid refrigerant from the receiver and pumping it directly into the discharge line of the screw compressor. This section will describe the purpose and function of the various components of the V-PLUS system. Please refer to Figures 1 thru 3 on pages 5 thru 7 for the location of these items.

V-PLUS PUMP

The V-PLUS pump is the “heart” of the V-PLUS System. The pump draws the liquid refrigerant from the receiver and injects it directly into the compressor discharge line. This is accomplished by developing a pressure difference between the receiver and the compressor discharge line.

PUMP MOTOR

The pump adjusts to changes in operating conditions by a solid state variable speed V-PLUS pump motor. The motor is controlled by temperature variances in the discharge and oil lines.

LUBRICATION LINE COMPONENTS

A ¼” oil line is installed to supply oil from the main oil distribution manifold of the screw compressor unit to the liquid refrigerant pump. After the system has been running for approximately one hour, the seal area and supply and return oil lines of the pump should be warm. This indicates oil flow. A ¼” needle valve is installed in this line for controlling the amount of oil used for lubrication. A ¼” check valve is also installed in this line to prevent back flow of the liquid refrigerant into the screw compressor oil circuit while the compressor is off.

PUMP INLET PIPING COMPONENTS

All liquid supply lines to the pump will be 1 ½” Sch. 80 pipe. A 1 ½” angle stop valve has been installed in this line. This valve enables the pump to be isolated for servicing. A 1 ½” liquid indicator also has been installed in this line to enable the operator to easily determine the quality of liquid being supplied to the pump.

VILTER MANUFACTURING CORPORATION

V-PLUS® PUMPED LIQUID UNITARY SYSTEM

PUMP OUTLET PIPING COMPONENTS

The liquid pump discharge line is $\frac{3}{4}$ " Sch. 80 pipe. A liquid line solenoid valve is installed in this line. This solenoid valve will stop the flow of liquid refrigerant into the screw compressor unit when the compressor is off. A $\frac{3}{4}$ " globe valve is also installed in this line so that the V-PLUS unit can be isolated for servicing.

LIQUID INJECTOR NOZZLE

The liquid injector nozzle is used to distribute the liquid refrigerant properly and efficiently into the screw compressor discharge line.

GAS PURGING VALVE

A gas purging valve is used to prevent pump cavitation due to flash gas. If flash gas is present, this valve would collect the vapor and bleed it back to the suction side of the system.

VILTER MANUFACTURING CORPORATION
V-PLUS® PUMPED LIQUID UNITARY SYSTEM
LIMITATIONS

Although the V-PLUS oil cooling system is well engineered and can be of tremendous value when used properly, the following limitations apply:

- a) This discharge temperature should be set no less than 10° higher than the system condensing temperature and not above 130° maximum temperature. This setting will enable all the liquid refrigerant to evaporate before the gas/oil mixture enters the oil separator.

- b) The V-PLUS pump pressure differential is limited to 25 psig on standard units. For units in excess of 25 psig, consult the Home Office.

- c) The V-PLUS is for use on systems with standard high pressure liquid source, subcooled to no lower than 20°F. For control pressure receiver source, a special 2HP system is required. Consult the Home Office for details.

VILTER MANUFACTURING CORPORATION

V-PLUS® PUMPED LIQUID UNITARY SYSTEM

Barber Colman

Temperature Controller Adjustments.

Note: Vilter Manufacturing currently uses a Fuji temperature Control.

Make sure the power is off and loosen the Love joy coupling between the pump and the motor And separate so that the motor will run separately from the pump.

Apply power to the control panel. The LED digital readout should now display the oil temperature. Control adjustment values and setpoint temperatures can also be selected for display from the control adjustments located beneath the front panel access door.

Depressing the large square Setpoint Display Pushbutton releases the mechanical brake on the setpoint thumbwheel and displays the first setpoint temperature on the digital readout. To identify that the setpoint is being displayed, the LED labeled "SP" (located to the right of the digital readout) will light. Turn the thumbwheel to adjust the first setpoint to 120° F.

A three position toggle switch is located under the access door on the right hand side which allows selection and display of control parameters. Changing the toggle switch position will not interrupt control operation, allowing the operator to check out or adjust any control setting safely. When the toggle switch is in the down position, (the normal run position), the control will display the process temperature. When the toggle switch is in the center position the control will display the primary setpoint but will not release the mechanical brake on the setpoint thumbwheel. When the toggle switch is in the up position (the select position) the control will display a different control function.

The first time the switch is toggled to the momentary select position, the value for GAIN is displayed on the digital readout and the -25 LED is lighted on the bar graph. Gain adjustment can then be made while observing the changing value on the digital readout. The normal gain setting will be between 5 and 15 with a factory setting of 10. If the oil temperature is not stable when the V-PLUS unit is running, make small adjustments and allow ample time for the controller to stabilize between adjustments.

VILTER MANUFACTURING CORPORATION

V-PLUS® PUMPED LIQUID UNITARY SYSTEM

Toggling the switch to the select position again (the second time) will advance the display to the BESET control parameter. The bar graph -10 LED will light to identify that the RESET value is displayed and can be adjusted at this time. The normal range is 150 to 200, with a factory setting of 200. Again allow ample time to stabilize between changes.

Toggling the switch to the select position again (the third time) will advance the controller to the third parameter, which is the coarse adjustment for the second setpoint. The -3 LED will light to verify that the display is indicating the spread coarse parameter. The parameter should be set 15°F below the first setpoint, or at 105°F. As this is the coarse adjustment, 105°F may not be possible to set. Get this as close to 105°F as possible.

Toggling the switch to the select position again (the fourth time) advances the controller to the fine adjustment of the second setpoint. The +5 LED will light indicating the mode of the control. This parameter should be set 15°F below the first setpoint, or 105°F.

These two settings (coarse and fine) must be made after the first setpoint is adjusted. The spread between the first and second setpoints will stay the same even if the first setpoint is changed. The second setpoint will then float with the first setpoint • In other words, once the second setpoint has been adjusted to 105°F (15°F below the first setpoint) it will remain 15°F below the first setpoint even if the first setpoint is changed,

Toggling the switch to the select position again (the fifth time) advances the controller to the third setpoint. The +10 LED will light indicating the mode of the control. The third setpoint controls a set of normally closed contacts in the Temperature Controller which may be used for the High Oil Temperature Alarm. These normally closed contacts, which open if the oil temperature rises, should be set at 140°F, Note: Not all temperature controls will have this alarm feature.

Once set, the third set point will remain at 140°F even if the first setpoint is readjusted.

VILTER MANUFACTURING CORPORATION

V-PLUS® PUMPED LIQUID UNITARY SYSTEM

SPEED CONTROL AND TEMPERATURE CONTROLLER START UP INSTRUCTIONS

The following settings for the Dart speed control and Fuji temperature controller have been made at the factory. Verify that the temperature control settings are correct by familiarizing yourself with the temperature control FRONT PANEL OPERATION, page 4 of the Fuji Manual. Control settings will have to be made to the Fuji temperature control if it is replaced in the field. The settings in the temperature control are as follows:

SETTINGS FOR V-PLUS

FUJI PXZ4 Control

Primary Menu

Parameter	Range	Description	Default Settings	DSP Settings	VILTER Settings
ProG	off/UnHld	Ramp/soak command	off	dSP1-1	OFF
P	0.0-999.9%FS	Proportional band	5.0	dSP1-2	50.8-20.8
I	0 - 3200 sec.	Integral time	240	dSP1-4	182
d	0.0 - 999.9 sec.	Derivative time	60	dSP1-8	1
AL	0 - 100% FS	Low Alarm Setpoint	10	dSP1-16	15
AH	0 - 100% FS	High Alarm Setpoint	10	dSP1-32	200
TC	1 - 160 sec.	Cycle Time (Output #1)	1	dSP1-64	---
HYS	0 - 50% FS	Hysteresis	1	dSP1-128	2.0
Hb	0.0 - 50.0 A	Heater-break alarm S.P.	0.0	dSP2-1	N/A
AT	0 - 2	Auto-tuning command	0	dSP2-2	N/A
TC2	1 - 160 sec.	Cycle Time (Output #2)	1	dSP2-4	N/A
Cool	0.0 - 100.0	Proportional band coefficient for cooling	1.0	dSP2-8	N/A
db	-50.0 - 50.5% FS	Deadband/Overlap	0.0	dSP2-16	N/A
PLC1	PLC1	N/A	-3.0	dSP2-32	N/A
PHC1	PHC1	N/A	103.0	dSP2-64	N/A
PCUT	PCUT	N/A	0	dSP2-128	N/A
bAL	0 - 100%	Balance	0.0 / 50.0	dSP3-1	50.0
Ar	0 - 100% FS	Anti-reset windup	100% FS	dSP3-2	100.0
LoC	0 - 2	Lock out	0	dSP3-4	0

FUJI PXZ4 Control

Secondary Menu

Parameter	Range	Description	Default Settings	DSP Settings	VILTER Settings
P-SU	P-SU	-1999 - 9999	Upper range of input	100% FS	dSP5-64 200
P-AL	P-AL	0 - 15	Alarm Type 2 code	9	dSP5-128 14
P-AH	P-AH	0 - 11	Alarm Type 1 code	5	dSP6-1 ---
P-Ah	P-Ah	0 - 50% FS	Alarm Hysteresis	1	dSP6-2 ---
P-dP	P-dP	0 - 2	Decimal point position	0	dSP6-4 ---
rCJ	rCJ			ON	dSP6-8 N/A
PVOF	PVOF	-10 - 10% FS	PV offset	0	dSP6-16 ---
SVOF	SVOF	-50 - 50% FS	SV offset	0	dSP6-32 ---
P-F	P-F	°C / °F	°C / °F Selection	1	dSP6-64 °F
PLC2	PLC2		N/A	-3.0	dSP6-128 N/A
PHC2	PHC2		N/A	103.0	dSP7-1 N/A
FUZY	FUZY	OFF / ON	Fuzzy control	OFF	dSP7-2 OFF
GAIN	GAIN		N/A	1	dSP7-4 N/A
AdJO	AdJO		Zero calibration	0	dSP7-8 N/A
AdJS	AdJS		Span calibration	0	dSP7-16 N/A
oUT	oUT		N/A	-3.0	dSP7-32 N/A
dSP1	dSP1	0 - 255	Parameter mask	1	---
dSP2	dSP2				253
dSP3	dSP3				248
dSP4	dSP4				255
dSP5	dSP5				3
dSP6	dSP6				136
dSP7	dSP7				125

Hold SEL button for 10 seconds to display secondary menu:

Secondary Menu

Parameter	Range	Description	Default Settings	DSP Settings	VILTER Settings
P-n1	P-n1	0 - 18	Control Action code	1	dSP5-4 16
P-n2	P-n2	0 - 16	Input type code	1	dSP5-9 2
P-dF	P-dF	0.0 - 900.0 sec.	Input filter constant	5.0	dSP5-16 4
P-SL	P-SL	-1999 - 9999	Lower range of input	0% FS	dSP5-32 0

NOTES:

1. Set speed control minimum to 150° for SV.
2. Set speed control maximum to 0° for SV.
(Voltage is 57VDC for 1/2HP and 1 HP)
(Voltage is 114VDC for 2HP)
3. Motor rotation is CCW opposite coupling end.

FIGURE 6. SETTINGS FOR V-PLUS

VILTER MANUFACTURING CORPORATION
V-PLUS® PUMPED LIQUID UNITARY SYSTEM

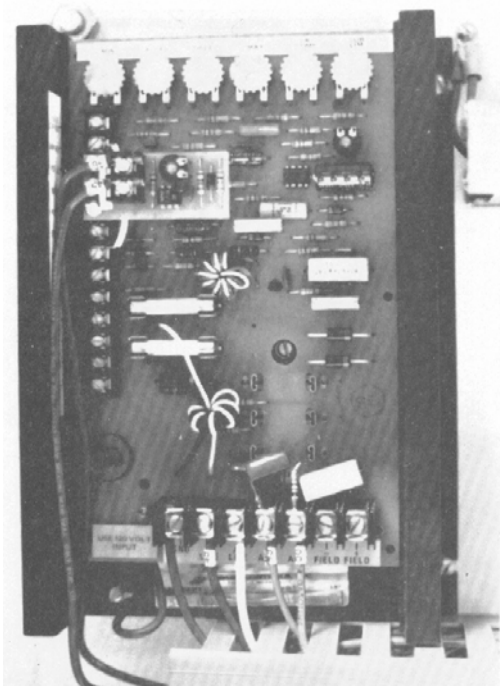

FIGURE 7. DART SPEED CONTROL

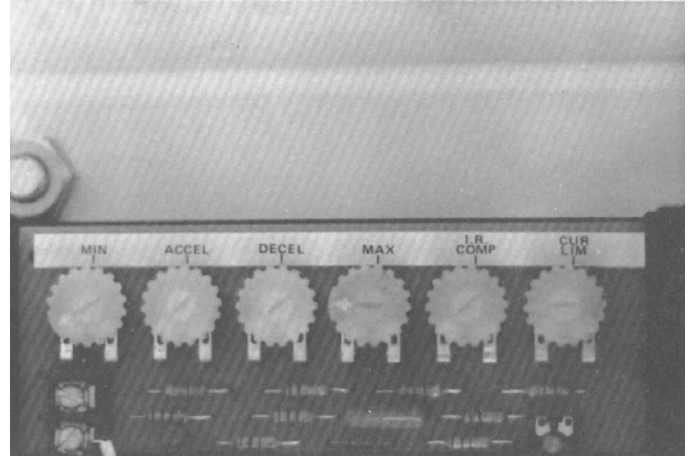

FIGURE 8. CLOSE-UP OF DART CONTROL SHOWING POTENTIOMETERS

Adjustments will have to be made to the Dart speed control if it is replaced in the field. Refer to the DART CONTROLLER POTENTIOMETER SETTINGS and adjust as follows:

With the power off to the control and the trimpot settings (refer to Figure 8) corresponding to the voltage and horsepower of the pump motor, loosen the Lovejoy coupling between the pump and motor, and separate so the motor will run independently of the pump. Place a temporary jumper wire from terminal 104 to terminal 105 on the terminal strip in the V-PLUS panel. Turn the power to the panel back on and change the setpoints variable (SV) to 150°F. Insure the rotation is in the correct direction by referring to Figure 8. Make sure the motor is running slow and steady. You should be able to count the fan blades on the motor at this speed. If the motor is running too fast, adjust the MIN speed trimpot on the Dart control until you can count the fan blades.

VILTER MANUFACTURING CORPORATION

V-PLUS® PUMPED LIQUID UNITARY SYSTEM

MIN	ACCEL	DECEL	MAX	L.R.	CUR LIM	HP	VOLTS
						1/2	115
						3/4	115
						1.0	115
						3/4	230
						1.0	230
						1.5	230
						2.0	230
						3.0	230

FIGURE 9 TRIMPOT SETTING CHART

Now change the SV to read 0°F. The motor should now be running at its maximum speed. Measure the DC voltage at terminal 109 and terminal 110. The voltage for a 1HP motor should be between 55 and 70 VDC, with an optimum setting of 57 VDC. If the speed is lower than 55VDC or higher than 70VDC, adjust the MAX trimpot until the desired maximum speed is achieved. The voltage for a 2HP motor should be between 110 and 140 VDC, with an optimum setting of 114VDC. If the speed is lower

VILTER MANUFACTURING CORPORATION

V-PLUS® PUMPED LIQUID UNITARY SYSTEM

than 110VDC or higher than 140VDC, adjust the MAX trimpot until the desired maximum speed is achieved. Reset SV to 120°F.

Remove power to the V-PLUS panel and reinstall the Lovejoy coupling. Remove the temporary jumper from terminals 104 and 105, and turn the power back on. The V-PLUS is now ready to run.

!! CAUTION !!

At no time should the current limit adjustment be changed. This adjustment is factory set and changing its setting could damage the pump motor.

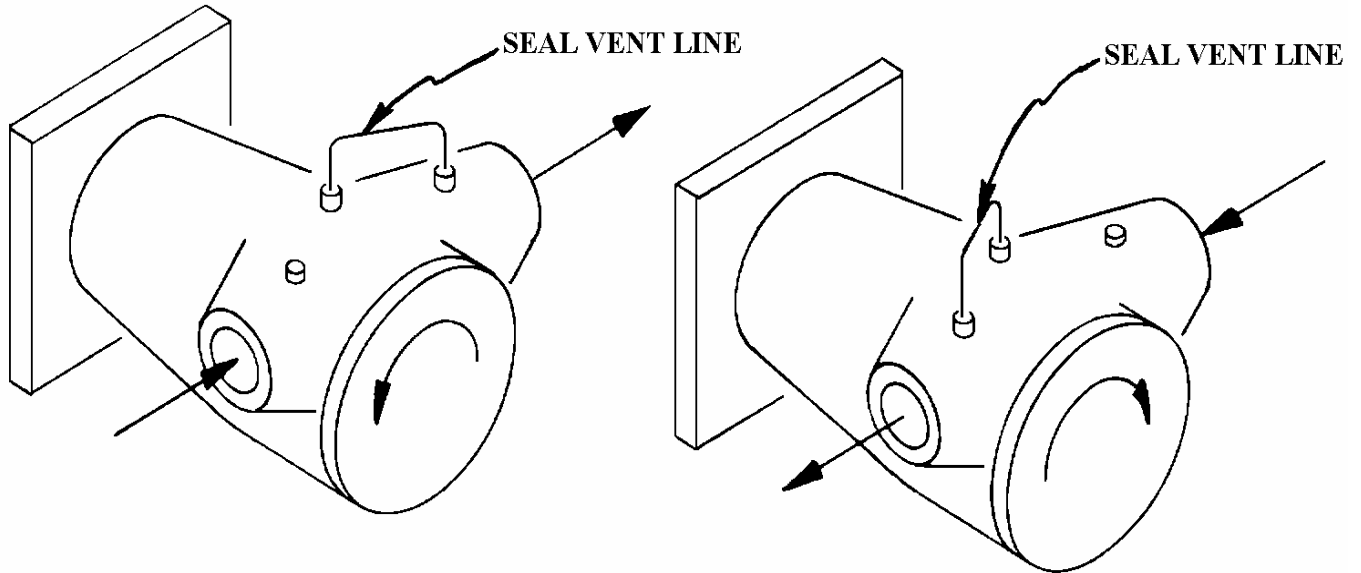

FIGURE 10. PUMP ROTATION DETAILS

VILTER MANUFACTURING CORPORATION

V-PLUS® PUMPED LIQUID UNITARY SYSTEM

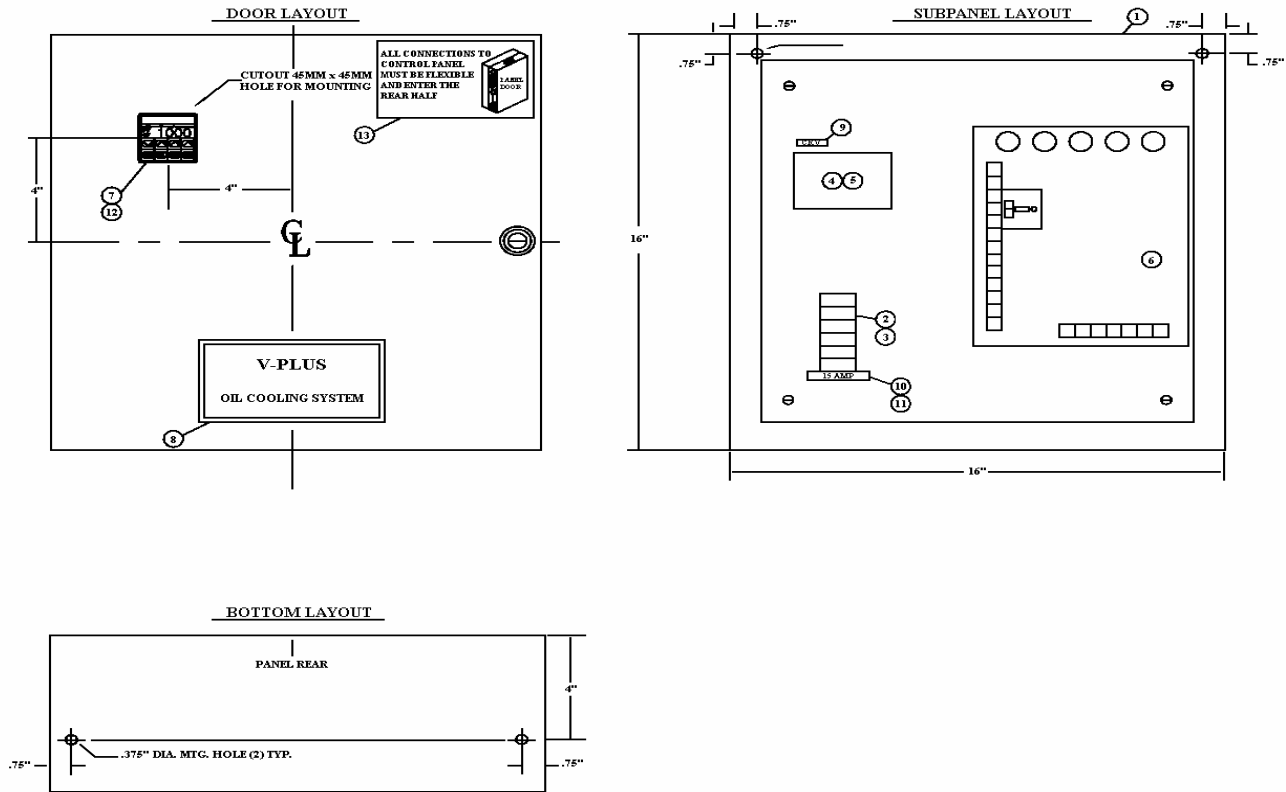

FIGURE 11. CONTROL PANEL ASSEMBLY – V-PLUS 1 HP

TABLE 3. REPLACEMENT PARTS LIST FOR FIGURE 11

Item Number	Description	Quantity Required	Part Number
1	Control Panel	1	3029A
2	Terminal Block, 25 amp, 600V	6	3089A
3	Rail, Din, 35mm Slotted	.375	3089H
4	Varistor, Metal Oxide	2	2533A
5	Relay, 115V/60H, Open, 2PDT	1	1537C *
6	Speed Control, 0-90VDC	1	2556A *
7	Temperature Controller	1	3014A *
8	Decal, V-PLUS Oil Cooling System	1	2461A
9	Label, ¼" x 1", Silver Component	1	2271D
10	Fuseholder, 30 amp, 600V	1	3090BB
11	Fuse, 15 amp, 125V	1	3090E *
12	Socket, 11-Pin	1	3014B
13	Sticker, Conduit Instruction	1	3028A
14	Network	2	3030B
15	Stop End, W Series	2	3089F
16	Plate End, W Series	1	3089C
17	Marker, Blank, W Series	1	3089G
18	Circuit Sticker, Data	1	2124A

NOTE: * Recommended Spare Parts

VILTER MANUFACTURING CORPORATION
V-PLUS® PUMPED LIQUID UNITARY SYSTEM

V-PLUS WIRING

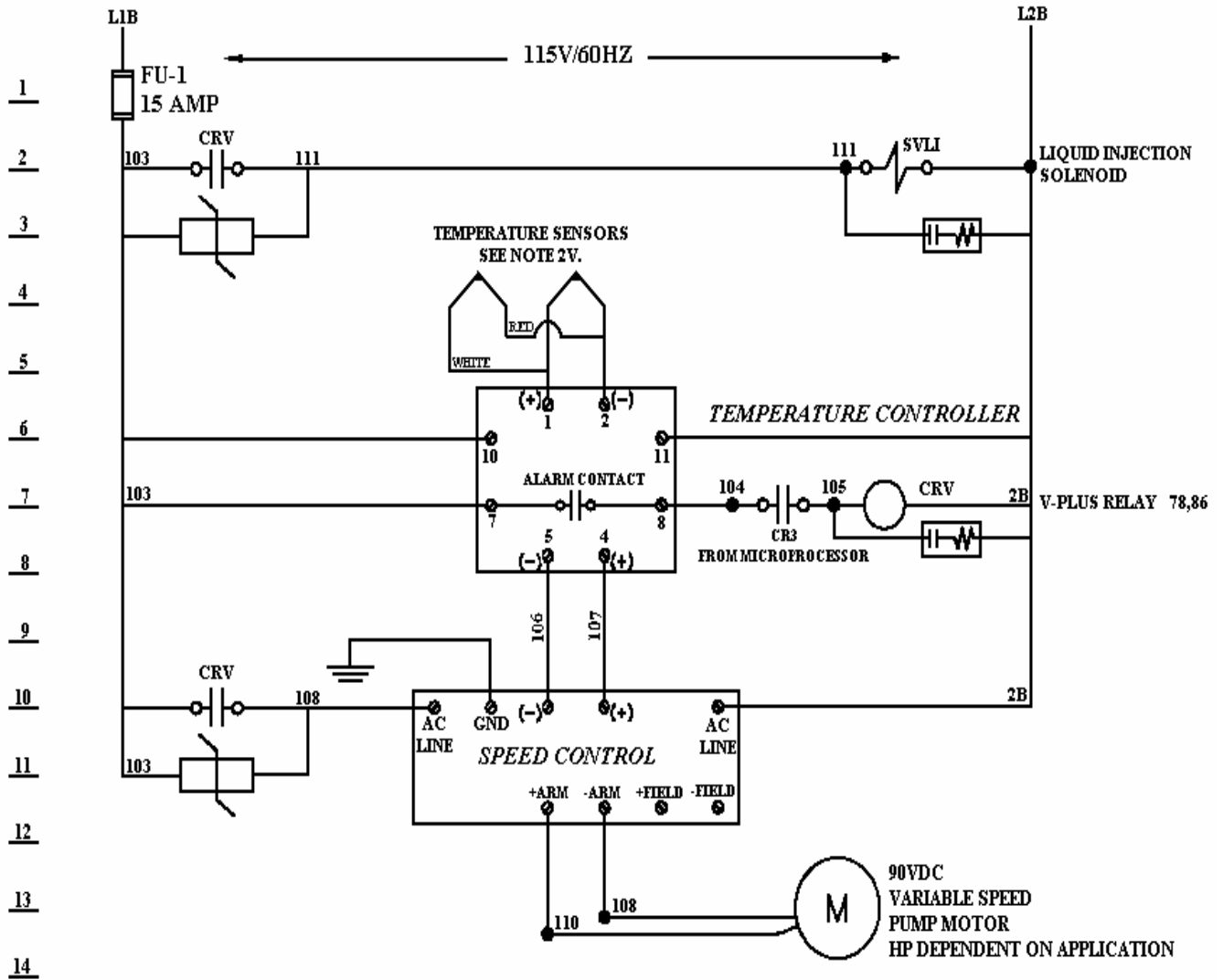

FIGURE 12. WIRING DIAGRAM – V-PLUS

VILTER MANUFACTURING CORPORATION

V-PLUS® PUMPED LIQUID UNITARY SYSTEM

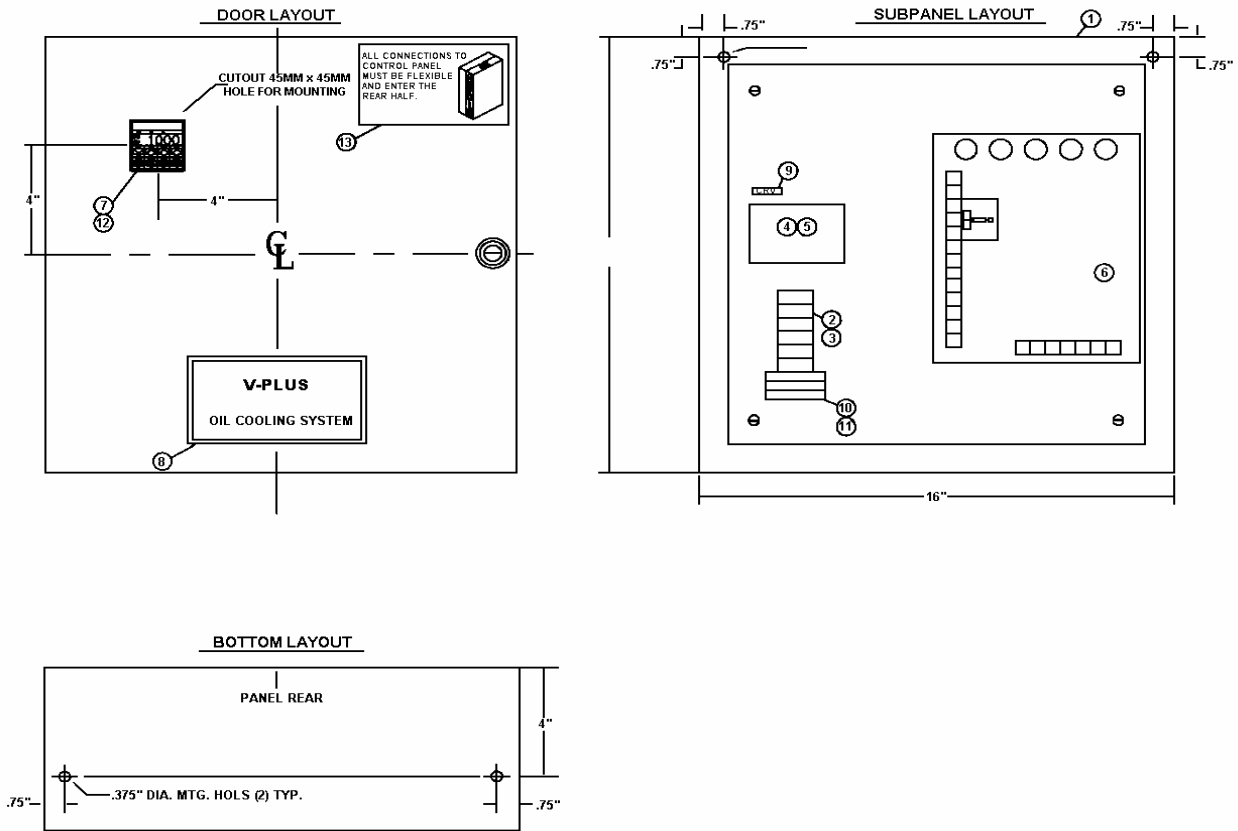

FIGURE 13. CONTROL PANEL ASSEMBLY – V-PLUS 2HP

TABLE 4. REPLACEMENT PARTS LIST FOR FIGURE 13.

Item Number	Description	Quantity Required	Part Number
1	Control Panel	1	3029A
2	Terminal Block, 25 amp, 600V	12	3089A
3	Rail, Din, 35mm Slotted	.500	3089H
4	Varistor, Metal Oxide	1	2533A
5	Relay, 115V/60H, Open, 2PDT	1	1537C *
6	Speed Control, 0-90VDC	1	2556A *
7	Temperature Controller	1	3014A *
8	Decal, V-PLUS Oil Cooling System	1	2461A
9	Label, ¼" x 1", Silver Component	1	2271D
10	Fuseholder, 30 amp, 600V	3	3090BB
11	Fuse, 15 amp, 125V	3	3090X *
12	Socket, 11-Pin	1	3014B
13	Sticker, Conduit Instruction	1	3028A
14	Varistor, Metal Oxide	1	2533B
15	Network	2	3030B
16	Stop End, W Series	2	3089F
17	Marker, Blank, W Series	1	3089G
18	Circuit Sticker, Data	1	2124A

NOTE: * Recommended Spare Parts

VILTER MANUFACTURING CORPORATION
V-PLUS® PUMPED LIQUID UNITARY SYSTEM

V-PLUS WIRING

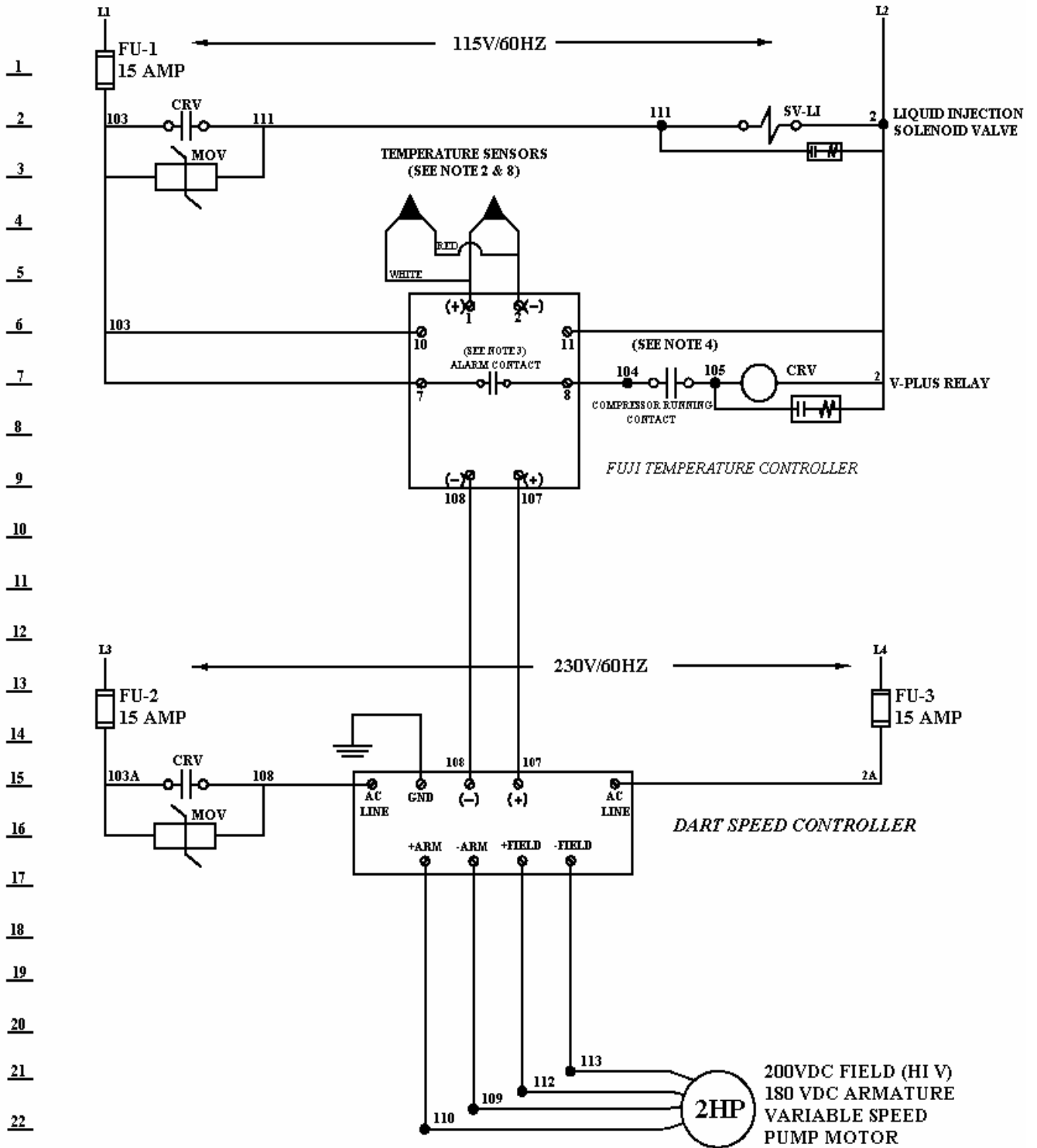

FIGURE 14. WIRING DIAGRAM – V-PLUS w/2HP MOTOR



**PID Autotune
Controllers
Featuring Fuzzy Logic**

TABLE OF CONTENTS

Model Configuration 1

Introduction..... 2

Features..... 2

Safety Precautions..... 2

Specifications..... 3

Outer Dimensions and Panel Cutout Size 5

Installation 5

Wiring Instructions: 6

Front Panel Description 8

Front Panel Operation 8

Autotuning..... 9

Programming

 1. Primary Menu 9

 2. Secondary Menu..... 13

Error Messages 15

Appendix A: Autotuning..... 16

Appendix B: Manual Tuning 17

Appendix C: Heater Break Option..... 19

Appendix D: Heat/Cool Option..... 20

Quick Reference..... 22

MODEL CONFIGURATION



Front panel size	Code
1/16 DIN	4
1/8 DIN	5
72mm	7
1/4 DIN	9

Kinds of input	Code
Thermocouple (°C)	T
Thermocouple (°F)	R
RTD/Pt100 (°C)	N
RTD/Pt100 (°F)	S
4-20mA DC, 1-5V DC	B
0-20mA DC, 0-5V DC	A

Control output 1	Code
Relay contact (reverse action)	A
Relay contact (direct action)	B
SSR/SSC driver (reverse action)	C
SSR/SSC driver (direct action)	D
4 to 20mA DC (reverse action)	E
4 to 20mA DC (direct action)	F

Control output 2*	Code
None	Y
Relay contact (reverse action)	A
Relay contact (direct action)	B
SSR/SSC driver (reverse action)	C
SSR/SSC driver (direct action)	D
4 to 20mA DC (reverse action)	E
4 to 20mA DC (direct action)	F

*not available on PXZ-4 type

Alarm Options	Code
Heater break alarm*	2
Process alarm & Heater break alarm*	3
None	4
Process alarm	5

*not available on PXZ-4, or with 4-20mA DC output

Power Supply Option	Code
24V AC/DC Supply	D

ACCESSORIES (Sockets: only for PXZ-4 and sold separately)

- 8-pin sockets** (for PXZ-4 without H / L Alarm Option)
- ATX1NS Solder Type Socket (UL)
 - PG-08 Screw-down type socket (terminals on back)
 - ATX2PSB Screw-down type socket (terminals on back) (UL)
 - TP26X Screw-down type socket (terminals on front) (UL)
- 11-pin sockets** (for PXZ-4 with H / L Alarm Option)
- PG-11 Screw-down type socket (terminals on back)
 - TP311SB Screw-down type socket (terminals on back)
 - TP311S Screw-down type socket (terminals on front)
- Heater Break Current Sensing Transformer:**
- CTL-6-SF For heater current (1 to 30 amps)
 - CTL-12-S36-8F For heater current (20 to 50 amps)

Free Technical Support:
1-800-235-8367 U.S. & Canada
802-863-0085 Int'l
8:30 A.M.- 6:00 P.M. E.S.T.

INTRODUCTION

Thank you for purchasing the Fuji Electric PXZ controller. All of these controllers are PID Autotune controllers that employ Fuji Electric's patented fuzzy logic algorithms.



It is a fully programmable temperature/process controller incorporating many user-friendly features. The following easy-to-use instructions are intended to help you understand, set up, effectively operate, and achieve optimal performance from your PXZ controller. When programmed and operated within the guidelines set up for them in this manual, your PXZ controller will give you years of precise, reliable control. If needed, we will provide free technical support throughout the life of the controller.

FEATURES

- Fuzzy Logic Control
- PID Autotune with manual override - heating or cooling
- Programmable control action - reverse or direct
- Programmable cycle time
- Programmable inputs - Thermocouple/RTD, or, Current/ and Voltage
- Sensor burn-out protection
- Input calibration by user
- Outputs: Relay, Solid-state relay drive, and 4-20mA DC
- Secondary output for cooling (optional)
- High/low alarm outputs (optional)
- Heater break alarm (optional) (only on PXZ-5, 7, 9)
- Menu driven format
- Setting – touch keys on front panel
- Programmable 8-segment ramp/soak function
- Digital filtering (to suppress factory noise)
- Adjustable setpoint range
- Selectable °F/°C
- Offset adjustments
- Programmable decimal point
- Programmable lock-up feature
- Advanced security options to prevent unauthorized parameter changes
- 4-digit, LED indication
- Output status indication
- Fault indication
- Non-volatile memory
- 1/16, 1/8, 1/4 DIN and 72mm panel mount package
- NEMA 4X faceplate
- ABS plastic housing
- Termination—screw-down type (PXZ-5, 7, 9) or socket with screw-down terminals (PXZ-4)
- Metal mounting bracket; plastic bracket for PXZ-4
- 85 to 264V AC free voltage power supply
- 24V AC/DC power supply (optional)
- UL, C-UL, and CE approvals
- 3-year warranty

SAFETY PRECAUTIONS

Before using this product, the user is requested to read the following precautions carefully to ensure safety. The safety requirements are classified as either "warning" or "caution" according to the following explanations:

 Warning	suggesting that the user's mishandling can result in personal death or serious injury.
 Caution	suggesting that the user's mishandling can result in personal injury or damage to the property.

Warning

Wiring

1. If there is danger of serious accident resulting from a failure or defect in this unit, provide the unit with an appropriate external protective circuit to prevent an accident.
2. The unit is normally supplied without a power switch or a fuse. Use power switch and fuse as required (Rating of the fuse: 250V, 1A)

Power supply

1. Be sure to use the rated power supply voltage to protect the unit against damage and to prevent failure.
2. Keep the power off until all of the wiring is completed so that electric shock and trouble with the unit can be prevented.

General

1. Never attempt to disassemble, modify, or repair this unit. Tampering with the unit may result in malfunction, electric shock, or fire.
2. Do not use the unit in combustible or explosive gaseous atmospheres.

Caution

Installation

1. Avoid installing the unit in places where:
 - the ambient temperature may reach beyond the range of -10 to 50°C (32 to 122°F) while in operation
 - the ambient humidity may reach higher than 90% RH while in operation
 - a change in the ambient temperature is so rapid as to cause condensation
 - corrosive gases (sulfide and ammonia gas, in particular) or combustible gases are emitted
 - the unit is subject to vibration or shock
 - the unit is likely to come in contact with water, oil, chemicals, steam, or vapor
 - the unit is exposed to dust, salt, or air containing iron particles
 - the unit is subject to interference with static electricity, magnetism, or noise
 - the unit is exposed to direct sunlight
 - heat may be accumulated due to radiation

Maintenance

1. Do not use organic solvents such as alcohol or benzene to wipe this unit. Use a neutral detergent.
2. Three-year warranty is guaranteed only if the unit is properly used.

SPECIFICATIONS

INPUT RANGE TABLE:

Input Signal	Input Range (°C)	Input Range (°F)	Remarks	
Thermocouple				
J	0~800	32~1472	Cold Junction compensating function built-in	
K	0~1200	32~2192		
R	0~1600	32~2912		
B	0~1800	32~3272		
S	0~1600	32~2912		
T	-199~200	-328~392		
T	-150~400	-238~752		
E	-199~800	-328~1472		
N	0~1300	32~2372		
PL2	0~1300	32~2372		
RTD				
Pt100	-150~850	-238~1562		Allowable wiring resistance 10 ohms max (per wire).
DC Voltage/Current				
1-5V 0-5V	Scaling Range: -1999 to 9999 Engineering Units		For current input, use the 250Ω resistor to obtain 1-5V DC or 0-5V DC input.	
4-20mA 0-20mA				

CONTROL FUNCTION

(SINGLE OUTPUT)

Control action	PID control with auto-tuning Fuzzy control with auto-tuning
Proportional band (P)	0-999.9%, of full scale (FS), setting in 0.1% steps
Integral time (I)	0-3200 sec, setting in 1 sec steps
Differential time (D)	0-999.9 sec, setting in 0.1 sec steps
P,I,D = 0:	2-position action
I,D = 0:	Proportional action
Proportional cycle	1-150 sec, setting in 1 sec steps, for relay contact output and SSR/SSC drive output only
Hysteresis width	0-50% FS, setting in 1 E.U. (Engineering Units) steps, 2-position action only
Anti-reset wind up	0-100% FS, setting in 1 E.U. steps, auto-setting with auto-tuning
Input sampling cycle	0.5 sec
Control cycle	0.5 sec

CONTROL FUNCTION

(DUAL OUTPUT) (Heat/Cool Type)

Heating Proportional band	$P \times 1/2$ (P= 0-999.9%)
Cooling Proportional band	Heating proportional band x Cooling proportional band coefficient Cooling proportional band coefficient= 0-100 0: 2-position action
Integral time	0-3200 sec for heating and cooling
Differential time	0-999.9 sec for heating and cooling
P,I,D= 0:	2-position action (without dead band) for heating and cooling
I,D= 0:	Proportional action
Proportional cycle	1-150 sec, for relay contact output and SSR/SSC drive output only
Hysteresis width	2-position action for heating and cooling: 0.5% FS

2-position action for cooling: 0.5% FS

Anti-reset wind-up	0-100% FS, setting in 1 E.U. steps, auto setting with auto-tuning
Overlap/dead band	±50% of heating proportional band
Input sampling cycle	0.5 sec
Control cycle	0.5 sec

OUTPUT

(Single Output)

Control output	One of the following three types is selected: (1) Relay contact (SPDT) 220V AC/30V DC, 3A (resistive load) Mechanical life: 10 ⁷ times (under no load) Electrical life: 10 ⁵ times (under the rated load) (2) SSR/SSC drive (voltage pulse): 15-30V DC at ON/0.5V DC or less at OFF. Current 60mA or less. (3) 4-20mA DC: Allowable load resistance— 600Ω or less.
----------------	---------------------------------------------------------------------------------------------------------------------------------------------------------------------------------------------------------------------------------------------------------------------------------------------------------------------------------------------------------------------------------------------------------------------

OUTPUT

(Dual Output)

Control output	For dual output type, one of the following three types is selected on both heating and cooling types: (Not available on PXZ-4 type) (1) Relay contact (SPDT): 220V AC/30V DC, 3A (resistive load) (2) SSR/SSC drive (voltage pulse): 15-30V DC at ON/0.5V DC or less at OFF. Current: 60mA or less (3) 4-20mA DC: Allowable load resistance – 600Ω or less (Note: When SSR/SSC drive output for heating/cooling side is selected, the total current should be less than 60mA)
----------------	----------------------------------------------------------------------------------------------------------------------------------------------------------------------------------------------------------------------------------------------------------------------------------------------------------------------------------------------------------------------------------------------------------------------------------------------------------------------------------------------------------

SETTING AND INDICATION

Parameter setting method	PXZ: digital setting with eight keys
PV/SV display method	PXZ-4: PV/SV red LED display, 4 digits PXZ-5, 7, 9: PV/SV individual LED display, 4 digits each, PV= red, SV=green
Status display	Control output, alarm output, heater break alarm output.
Setting accuracy	0.1% FS
Indication accuracy (at 23°C)	Thermocouple: ± 0.5% FS ± 1 digit ± 1°C R thermocouple: 0-400°C; ± 1% FS ± 1 digit ± 1°C B thermocouple: 0-500°C; ± 5% FS ± 1 digit ± 1°C RTD, voltage, current: ± 0.5% FS ± 1 digit

ALARM

Alarm output	Relay contact (SPST), 220V AC/30V DC, 1A (resistive load) PXZ-4 type: 1 point Other types: 2 points
Heater break alarm output	Relay contact (SPST), 220V AC/30V DC, 1A (resistive load) PXZ-4 type: not available

GENERAL SPECIFICATIONS

Rated voltage	85-264V AC or 24V AC/DC
Power consumption	10VA or less (100V AC) 15VA or less (240V AC)
Insulation resistance	50M Ω or more (500V DC)
Withstand voltage	Power source-Earth: 1500V AC, 1 min Power source-input terminal: 1500V AC, 1 min Earth-relay output: 1500V AC, 1 min Earth-Alarm output: 1500V AC, 1 min Between other terminals: 500V AC, 1 min
Input impedance	Thermocouple: 1M Ω or more Voltage: 450K Ω or more Current: 250 Ω (external resistor)
Allowable signal source resistance	Thermocouple: 100 Ω or less Voltage: 1K Ω or less
Allowable wiring resistance	RTD: 10 Ω or less per wire
Reference junction compensation accuracy	± 1 °C (at 23°C)
Process variable offset	$\pm 10\%$ FS
Setpoint variable offset	$\pm 50\%$ FS
Input filter	0-900.0 sec, setting in 0.1 sec steps (primary lagging filter)
Noise rejection ratio	Normal mode noise (50/60Hz): 50dB or more Common mode noise (50/60Hz): 140dB or more

POWER FAILURE PROTECTION

Memory protection:	Non-volatile memory. Parameter values remain unchanged with disruption of power. Ramp/soak function has to be re-initiated.
--------------------	--------------------------------------------------------------------------------------------------------------------------------

SELF-CHECK

Method:	Watchdog timer monitors program error.
---------	----------------------------------------

OPERATION AND STORAGE CONDITIONS

Operating temperature	-10 to 50°C (14 to 122°F)
Operating humidity	90% RH or less (non-condensing)
Storage temperature	-20 to 60°C (-4 to 140°F)
Installation category	II
Pollution degree	2

OTHER FUNCTIONS

Parameter mask function	Parameter display is disabled by software
Ramp soak function	4-ramp/4-soak

STRUCTURE

Mounting method	Panel flush mounting or surface mounting Surface mounting: PXZ-4 type only
External terminal	PXZ-4 type: 8-pin or 11-pin socket Other types: screw terminal (M3.5 screw)
Enclosure	Black ABS plastic
Dimensions	PXZ-4 48 x 48 x 85.7mm (1/16 DIN) PXZ-5 52.5 x 100.5 x 95.8mm (1/8 DIN) PXZ-7 76.5 x 76.5 x 95.8mm (72 mm) PXZ-9 100.5 x 100.5 x 95.8mm (1/4 DIN)
Weight	PXZ-4 approx. 150g PXZ-5 approx. 300g PXZ-7 approx. 300g PXZ-9 approx. 400g
Protective structure	Front panel water-proof structure; NEMA 4X (equivalent to IEC standards IP66) Rear case: IEC IP20

DELIVERY

PXZ-4 type: controller, panel mounting bracket, socket (when specified), water proof gasket, 250 Ω precision resistor (when required), instruction manual. Other types: controller, panel mounting bracket, water-proof gasket, 250 Ω precision resistor (when required), instruction manual.

OUTER DIMENSIONS AND PANEL CUTOUT SIZE

PXZ 4

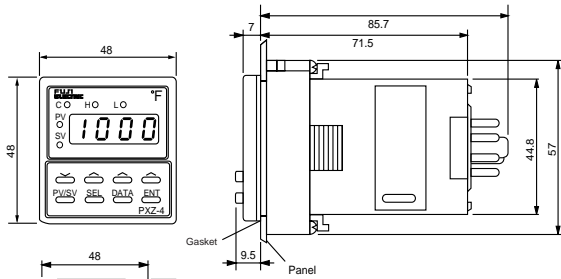

Unit: mm
Panel thickness: 1 to 8 mm

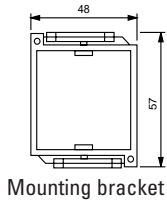

Panel cutout size: when installing "n" numbers of units.

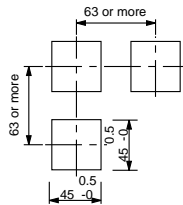

INSTALLATION

NEMA 4X Integrity

The front side of this instrument conforms to NEMA 4X. To ensure the waterproofness between the instrument and the panel, use the gasket that is provided with the unit according to the installation procedure described below.

How to install the unit

For PXZ-5/7/9, install the two metal brackets, one on the top and the other on the bottom, and tighten the screws to a torque of about 14.7N-cm (1.5kg-cm). For PXZ4, install the unit in the panel as shown below, and tighten the screws on the mounting bracket until the unit is secure. Make sure there is no space between the front side of the unit and the gasket, and between the gasket and the panel.

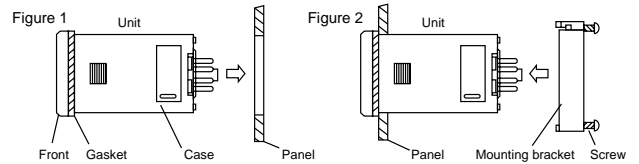

Caution: After the mounting bracket is installed, check the gasket for displacement and detachment as shown in Figure 3.

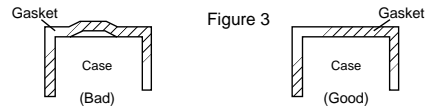

PXZ 5,7,9

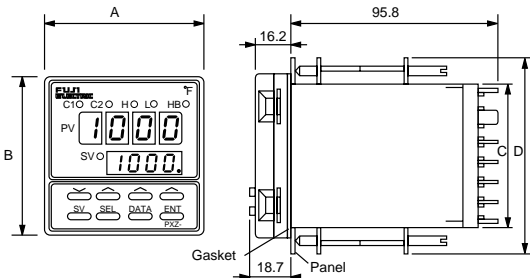

Unit: mm
Panel thickness: 1 to 8 mm

Model	A	B	C	D	E	F	G	H
PXZ5	52.5	100.5	90.5	114.5	45 ^{0.6} ₋₀	92 ^{0.8} ₋₀	120Min.	92Min.
PXZ7	76.5	76.5	67	91	68 ^{0.7} ₋₀	68 ^{0.7} ₋₀	96Min.	116Min.
PXZ9	100.5	100.5	90.5	114.5	92 ^{0.8} ₋₀	92 ^{0.8} ₋₀	120Min.	140Min.

Panel cutout size: when installing "n" numbers of units.

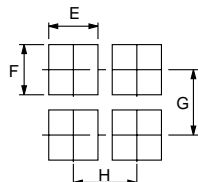

WIRING INSTRUCTIONS

⚠ Be sure to use the rated power supply voltage and polarity

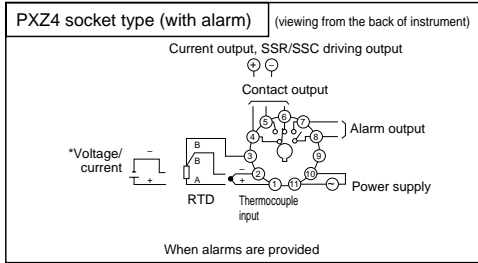
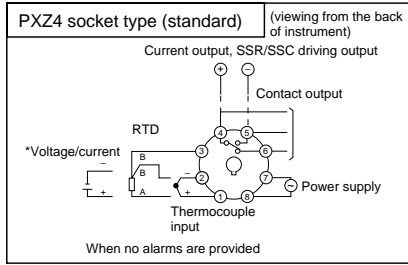

* For current input, install the 250Ω precision resistor (accessory) before using the unit.

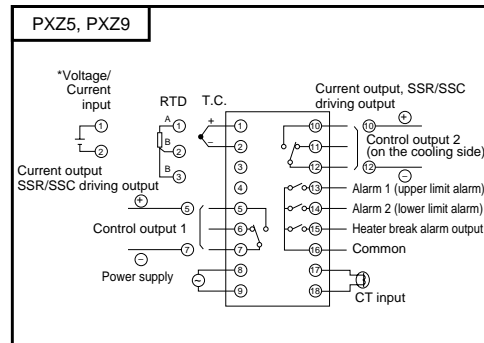
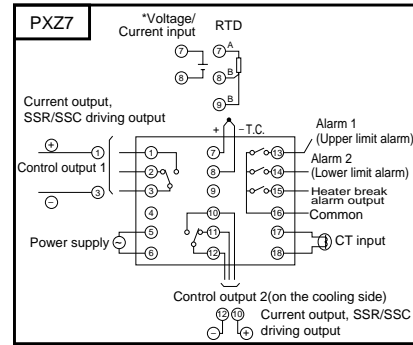

Wiring Power to Controllers

- Be sure to use the rated power supply voltage and polarity for the unit to protect it against damage and to prevent the occurrence of failure.
- Keep the power off until all of the wiring is completed to prevent electric shock and abnormal operation.
- Keep the power supply wires separated from the input and output wires.
- Power connections should be made with 18-gauge or larger insulated wire. Stranded wire improves noise immunity. Noise filters and isolation transformers are recommended in case of noisy power lines.
- When the Heater Break option is selected, use the same power line for both the controller and the heater.

Wiring Inputs

There are two input categories available: Thermocouple/RTD or current/voltage. Make sure you have the right type before wiring the inputs. Refer to Table of Input Type Codes and set the parameter "P-n2" accordingly.

Note: In order to minimize the risk of high frequency noise induced by coils and windings in relays, solenoids, and transformers, use leads which have braided sheath and ground one end of the sheath. Keep your input leads separate from power and output leads. If you have to bring the input signal from a long distance, a signal transmitter might be needed to maintain an accurate reading; in this case, a unit

that accepts current/voltage input would be necessary.

Thermocouple

- Connect thermocouples directly to the input terminals whenever possible.
- If using extension wires, make sure they are of the same thermocouple material and grade; any dissimilar metal junctions will lead to erroneous readings.
- Ungrounded thermocouples are recommended for optimal performance and to prevent ground loops.
- Make sure the polarity is correct.

RTD Pt100

- Use a 3-wire Pt100Ω RTD whenever possible. All three wires must have low lead resistance (less than 10Ω) and no resistance differentials among them.
- If using a 2-wire RTD, jumper the two B-legs with a wire of equal resistance.
- Make sure A and B leads are connected to the right terminals.

Current/Voltage

- The controller accepts 1-5V, 0-5V, 4-20mA, and 0-20mA DC signals. If wiring for a voltage input, feed the signal directly to the input terminals. For current inputs, first connect the 250Ω precision resistor that comes with the unit.
- Make sure the polarity is correct.

Wiring Outputs

Before wiring the outputs, make sure the unit has the right kind of control output, and that all the load handling devices conform to the controller specifications. Note that it takes 5 seconds for the outputs to activate after the power is turned on.

Refer to parameter “P-n1” and to the Table of Output Type Codes to choose the preferred type of control action— reverse acting or direct acting. If using two outputs in a heat/cool type control, please refer to Appendix D for more details.

Relay

- Connecting a load to full capacity of the relay will shorten the relay life, especially if it is operated at a rapid rate. To protect the output relay, an external relay or a contactor should be used. If a higher current rating is required, a solid-state relay driver type output is recommended.
- Connect the load between the normally opened contacts of the relay. This way, if power to the controller is disrupted, the output circuit would open, preventing the load from running out of control.
- Set the proportional time cycle parameter, “**TC**” to 30 secs. or more.
- Use of “Z-trap” (manufacturer: Fuji Electric Co.) is recommended to protect the relay against switching surges and to ensure the product’s long life. Connect it between the contacts of the relay as shown in the example.

Part No.:

ENC241D-05A (power supply voltage: 100V)

ENC471D-05A (power supply voltage: 200V)

PXZ4
(8-pin)

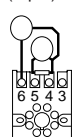

PXZ9

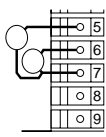

System Wiring Diagram

Example:

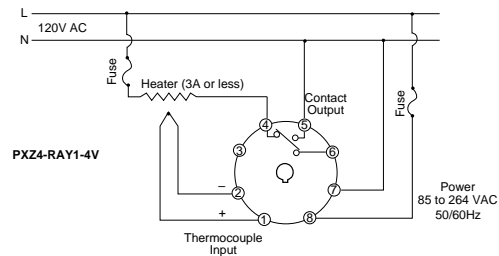

SSR/SSC Driver (Pulsed DC Voltage)

- The non-isolated DC output is used to drive an external load-handling device such as Solid-State Relay(SSR) or Solid-State Contactor(SSC).
- The total current drawn, for both single and dual outputs, should be within the allowed value.
- Make sure the polarity is correct.
- Set the proportional time cycle parameter, “**TC**” to 1 sec. or more.

4 to 20mA DC

- The output is a non-isolated analog signal used to drive a variety of output devices such as SCRs and valve actuators.
- The load resistance must be less than 600Ω.
- Make sure the polarity is correct.
- The proportional time cycle parameter, “**TC**” is set to 0, and is not displayed on the programming menu.

Wiring Alarms

- Make sure the load does not exceed the rated capacity of the relay.
- Several types of alarm configurations can be programmed and does not require a change in the wiring. Refer to parameters **AL**, **AH**, **P-AH**, **P-AL**, **P-An**.
- For details on Heater Break alarm, please refer to Appendix D and the Heater Break Alarm Setpoint parameter “Hb” in the programming section.

FRONT PANEL DESCRIPTION

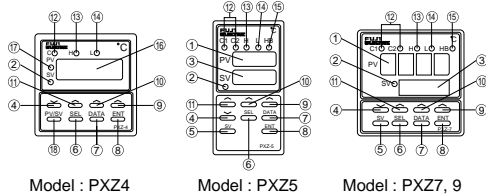

Name	Function
① Process Value (PV) display	Displays the process value (PV).
② Set value (SV) indication lamp	Stays on while a set value is on the display.
③ Set value (SV) and parameter display	Set value (SV) or parameter symbols and codes are displayed when setting various parameters.
④ DOWN key (common for each digit)	Decrements the numerical value in the place selected with the UP key. Where various parameters are displayed, each parameter is displayed one by one every time this key is pressed. The sequence of displays however, is opposite to the sequence of displays with the SEL key.
⑤ Direct SV key	By pressing this key, the set value (SV) is displayed.
⑥ SELECT key	The key to be used when switching over to the 1st or 2nd block parameters, or when scrolling through the parameters within a block.
⑦ Data display key	Displays the data assigned to the parameter selected with the SEL key
⑧ Data entry key	The key to be used for storing the data after previous data is changed. (none of changed data can be registered unless this key is pressed.)
⑨ UP key for 1's place	By pressing once, the number in the units place blinks. The number is continuously incremented with the key held pressed.
⑩ UP key for 10's place	By pressing once, the number in the tens place blinks. The number is continuously incremented with the key held pressed.
⑪ Up key for 100's place	By pressing once, the number in the hundreds place blinks. The number is continuously incremented with the key held pressed. A numeric "9" is followed by "0" and , concurrently, a number of the thousands place is incremented by 1.
⑫ Control output indication lamp	C (for PXZ4 only): Comes on when the control output is ON. C1: Comes on when the control output 1 is ON. C2: Comes on when the control output 2 is ON.
⑬ Upper limit alarm indication lamp (option)	Comes on when the upper limit alarm is activated.
⑭ Lower limit alarm indication lamp	Comes on when the lower limit alarm is activated.
⑮ Heater break alarm indication lamp	Comes on when the heater break alarm is output.
⑯ Process value (PV)/ set value (SV)/parameter display (applicable to PXZ4 only)	Parameter symbols and codes are displayed for process value (PV) and set value (SV) and when setting various parameters.
⑰ Process value (PV) indication lamp	Stays on while process value (PV) is on display.
⑱ PV/SV SELECT key (For PXZ4 only)	The display of measured value (PV) and set value (SV) is toggled each time this key is pressed.

FRONT PANEL OPERATION

The PXZ controller programming menu consists of two blocks—PRIMARY (SETPOINT) MENU and SECONDARY (SYSTEM) MENU. At power up, the controller will be in the operational mode— process variable (PV), in the case of PXZ4, and both process variable and setpoint variable (SV), in the case of PXZ-5, 7, 9 will be displayed. PV is the variable that is being controlled, and it is not programmable. When setting the parameters, turn off the power to the load (operating equipment) to ensure safety. Since it takes 30 minutes for the unit to stabilize in terms of temperature, all measurements should be carried out at least 30 minutes after the power is turned on. Option-related features are displayed only when the options are provided.

Viewing and Setting Parameters

- After setting the data, press ENT key for registration.
- If the data setting is left as it is for 30 secs, the display is automatically returned to the operational mode.

How to set Setpoint value (SV)

Operation	Display
1. Power on	– Operational mode
2. Press UP (units, tens or hundreds) key to select digit	– Digit blinks
3. Press the appropriate UP key or the DOWN key to increment or decrement digit value	– SV value changes
4. Press ENT key	– SV value registered

PRIMARY (SETPOINT) MENU

Operation	Display
1. Operational mode	– PV, SV
2. Press SEL key	– "P" displayed
3. Press DATA key	– "P" data displayed
4. Press the appropriate UP key once	– Corresponding digit blinks
5. Press the same UP key or the DOWN key to increment or decrement the data	– Data changes accordingly
6. Press ENT key	– Data registered; "i" displayed
7. Press SEL key once to go to the next parameter, or press and hold UP (hundreds) key or DOWN key to scroll down or up the menu at a faster rate	– "d" "Mod"
8. Press SV (SV/PV for PXZ4) key	– Operational mode

SECONDARY (SYSTEM) MENU

Operation	Display
1. Operational mode	– PV, SV
2. Press SEL key for about 3 secs	– "P-n1"
3. Press DATA key	– "P-n1" data
4. Proceed as described before.	

AUTOTUNING

Before initiating the autotune function, first decide if you would like to autotune at setpoint or 10% of full scale below setpoint. Set the setpoint (SV), alarms (AL, AH) and the cycle time (TC). Bring your process near setpoint before starting the autotune procedure.

Set the parameter AT to either "1" (to autotune at setpoint) or "2" (to autotune at 10% of full scale below setpoint) and press ENT key to start auto-tuning. The point indicator at lower right will then start blinking. When the auto-tuning is completed, the point indicator stops blinking and the parameter AT will automatically be set to "0."

Duration of the autotune process varies with every application. The auto-tuning process may take between 1 and 30 minutes to complete. If it fails to complete, an abnormality may be suspected. In this case, recheck the wiring, control action, and input type code. Refer to page 16 and Appendix A for additional details.

The PID parameters calculated by autotuning will be retained even if the power is lost. However, if the power is turned off during the auto-tuning process, you must restart autotuning. To abort the autotune procedure, set AT to "0." Auto-tuning has to be repeated if there is a significant change in SV, P-SL or P-SU, or in the controlled process. Autotuning can also be performed while fuzzy control is selected.

PRIMARY MENU SETTINGS

PARAMETER DESCRIPTION

-	SV	Main Setpoint Variable: The main setpoint variable is the control point you wish to maintain. The main setpoint variable is set within the input range, between the (P-SL) and the (P-SU) settings.
ProG		Ramp/Soak Command: The Ramp/Soak program automatically changes the setpoint value with time in accordance with a preset pattern. ProG switches the operation modes. Setting: oFF : Normal operation is performed rUn : Ramp/Soak operation is performed hLd : Ramp/Soak operation is suspended
P		Proportional Band: The proportional band is that area around main setpoint where the control output is neither fully on nor fully off. Setting range: 0.0 to 999.9% of full scale For On/Off control, set to "0"
I		Integral Time (reset): The Integral Time is the speed at which a corrective increase or decrease in output is made to compensate for offset which usually accompanies proportional only processes. The more Integral Time entered, the slower the action. The less Integral Time entered, the faster the action. Enter as little Integral Time as necessary to eliminate offset without overcompensating resulting in process oscillation. Setting Range: 0 to 3200 secs Integral Action is turned off when set to "0"
d		Derivative Time (Rate): The Derivative Time is that time used in calculating rate of change and thermal lag in helping eliminate overshoot which results in response to process upsets. This overshoot usually accompanies proportional only and proportional-integral processes. The derivative action dampens proportional and integral action as it anticipates where the process should be. The more Derivative Time entered, the more damping action. The less Derivative Time entered, the less damping action. Enter as much Derivative Time as necessary to eliminate overshoot without over-damping the process resulting in process oscillation. Setting Range: 0 to 999.9 secs Derivative Action is disabled when set to "0"

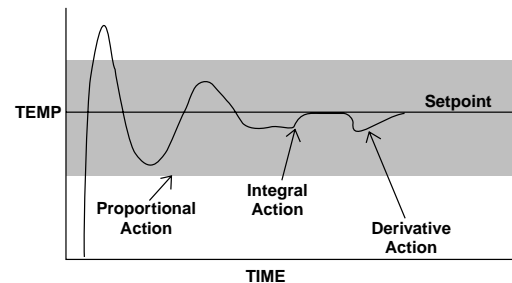

AL Low Alarm Setpoint: The Low Alarm Setpoint is that point of the process below which, the low alarm output relay is energized. If the alarm type, programmed in the secondary menu, includes an absolute value for the Low Alarm Setpoint, enter the actual value you want the alarm to be activated at regardless of what the main setpoint is set for. If the alarm type includes a deviation value for the Low Alarm Setpoint, enter the number of units below main setpoint in which you want the alarm to be activated at; the deviation alarm tracks main setpoint.
 Settable within the Input Range.
 Not indicated without the alarm option.

AH High Alarm Setpoint: The High Alarm Setpoint is that point of the process above which, the high alarm output relay is energized. If the alarm type, programmed in the secondary menu, includes an absolute value for the High Alarm Setpoint, enter the actual value you want the alarm to be activated at regardless of what the main setpoint is set for. If the alarm type includes a deviation value for the High Alarm Setpoint, enter the number of units above main setpoint in which you want the alarm to be activated at; the deviation alarm tracks main setpoint.
 Settable within the Input Range.
 Not indicated without the alarm option.

TC Cycle Time (Output #1): The Cycle Time for output #1 is that time where the output is on for a percentage of that time and off for a percentage of that time, creating a proportioning effect. The Cycle Time is only used when the PXZ is used as a P, PI, PD, or PID controller and when the output is time proportional as with the relay or SSR/SSC drive outputs. The shorter the Cycle Time, the higher the proportioning resolution is, and better is the control, but there will be an increased strain on the output device. Enter a value that is based on the limitations of your controller's output type.
 Setting range: 1 to 150 secs.
 For relay output: Set to 30 secs or more
 For SSR/SSC drive output: Set to 1 sec or more
 For current output: Set to 0. (normally not indicated).

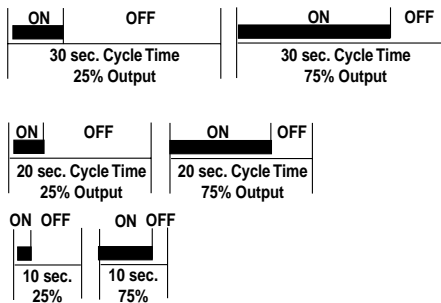

HYS Hysteresis: The Hysteresis is that area around the main setpoint where the output does not change condition. That area or deadband is intended to eliminate relay chatter at setpoint for On/Off control applications. The wider the Hysteresis, the longer it takes for the controller to change output condition. The narrower the Hysteresis, the less time the controller takes to change output condition. When the Hysteresis is narrow, the On/Off control is more accurate but the wear on the output relay is increased. Enter a value which is small enough to meet the control tolerance of the application but large enough to eliminate relay chatter.
 Setting range: 0 to 50% of full scale, set in E.U.
 Hysteresis for On/Off action on dual outputs (heating and cooling) is fixed at 0.5% of full scale.

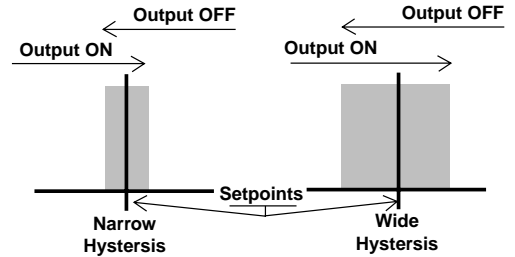

Hb Heater Break Alarm Setpoint: If the heater's operating current falls below this setpoint, the heater break alarm output relay is energized. This option is used in cases where the PXZ is controlling a bank of heaters wired in parallel. A current transformer around the hot lead going to the heater bank and connected to the controller is tied with the controller's output and senses the current used by the heater bank. If one or more of the zones burnout, resulting in cold spots, the current used by the defective heater bank is reduced. By determining what the optimal current and the optimal current minus one zone for the heater bank is, the Heater Break Alarm setpoint can be calculated and entered.
 Setting Range: 0 to 50 amps.
 Not indicated without the Heater Break Alarm output option.
 Not available on PXZ4, or with 4-20 mA DC outputs.
 Detection is made only on a single-phase heater. This function cannot be used when controlling a heater with SCR phase-angle control.
 Cycle Time, "TC," must be set at 6 secs. or higher
 Refer to Appendix C for more details.

$$\begin{array}{l}
 \text{Optimal Current of} \\
 \text{Heater Bank} \\
 \text{minus} \\
 \text{Optimal Current of} \\
 \text{Heater Bank} \\
 \text{less One Zone}
 \end{array}
 +
 \begin{array}{l}
 \text{Optimal Current of} \\
 \text{Heater Bank} \\
 \text{less One Zone}
 \end{array}
 =
 \begin{array}{l}
 \text{Heater} \\
 \text{Break} \\
 \text{Alarm} \\
 \text{Setpoint}
 \end{array}$$

2
Hb

AT Autotuning: Autotuning is the automatic calculation and entering of the control parameters (P, I and D) into memory. The PXZ will autotune both reverse and direct acting control applications. Autotuning will also automatically set anti-reset wind-up (Ar). There are two types of Autotuning that can be performed by the controller, Autotuning at main setpoint or Autotuning at 10% of full scale below main setpoint. Autotuning at 10% of full scale below main setpoint may yield slightly different values, not as precise, but the process overshoot encountered during the autotuning procedure would not be as great. Enter the value for the type of autotuning you would like to run on your particular application based on overshoot tolerances and the precision of the PID parameters needed. For more information on principles of Autotuning, refer to Appendix A. See also page 9.

- Setting:
 0 - Autotuning off
 1 - Autotuning performed at setpoint
 2 - Autotuning performed at 10% of full scale below setpoint

Standard type (AT=1)

Low PV type (AT=2)

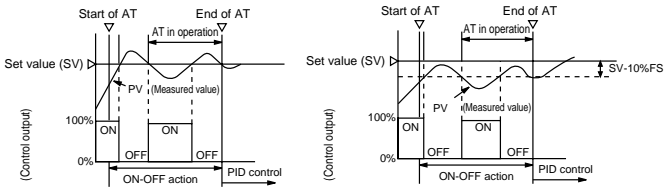

TC-2 Cycle Time (Output #2) The Cycle Time for output #2 is that time where the output is on for a percentage of that time and off for a percentage of that time, creating a proportioning effect. Output #2 is the cooling side of a heat/cool PXZ controller. A shorter cycle time provides higher proportioning resolution and better control but causes increased strain on the output device. Enter a value that is based on the limitations of your controller's output type.
 Setting Range: 1 to 150 secs.
 For relay output: Set to 30 secs or more
 For SSR/SSC drive output: Set to 1 sec or more
 For current output: Set to 0 (normally not indicated).
 Not indicated without the control output #2 option.

COOL Proportional Band Coefficient for Cooling: The Proportional Band Coefficient for Cooling is a multiplier for the proportional band on the cooling side of a heat/cool PXZ controller. It varies the width of the proportional band on the cooling side. A large value would establish a larger proportional band for more powerful cooling loads. A small value would establish a smaller proportional band for less powerful cooling loads. Enter a value based on the power of your cooling load.

Setting Range: 0.0 to 100.0
 Not indicated without control output #2 option.
 Set to "0" for On/Off control.

Proportional Band

$$\text{Prop. Band for Heating X Input Range} = \frac{P}{2}$$

$$\text{Prop. Band for Cooling X Input Range} = \frac{P}{2} \times \text{Cool}$$

$$\text{Deadband/Overlap X Input Range} = \frac{P}{200\%} \times db$$

db Deadband/Overlap: The Deadband/Overlap is that percentage of the heating side of the proportional band where the heating (output #1) and the cooling (output #2) outputs are separated by a Deadband or where they Overlap on a heat/cool PXZ controller. A value greater than zero establishes a Deadband or area where neither the heating nor cooling outputs are energized for more powerful heating and cooling loads. A value less than zero establishes an Overlap or area where both the heating and cooling outputs are energized at the same time for less powerful heating and cooling loads. Enter a value based on the power of your heating and cooling loads as well as the application's efficiency in maintaining tight heat/cool control. Setting range: -50.0 to 50.0% of the heating proportional band.

Not indicated without control output #2 option

Deadband/Overlap

$$\frac{\text{Prop. Band for Heating X Input Range}}{100\%} = \frac{\text{\# of units in the Proportional Band for Heating}}{100\%}$$

$$\frac{\text{Prop. Band for Cooling X Input Range}}{100\%} = \frac{\text{\# of units in the Proportional Band for Cooling}}{100\%}$$

$$\frac{\text{Deadband/Overlap X Input Range}}{100\%} = \frac{\text{\# of units in the Deadband/Overlap}}{100\%}$$

$$\text{Input Range} = (P - SL) \text{ minus } P - SL$$

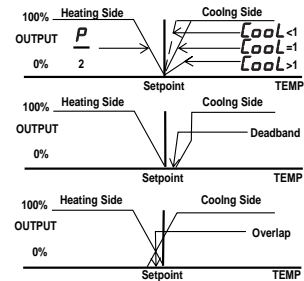

bAL Balance: Balance is used to pre-position the proportional band with respect to setpoint. With Balance (MV Offset) set at 50% the proportional band will be centered around setpoint. To move the band left or right, decrease or increase the balance setting respectively. Setting range: 0-100%

Ar Anti-Reset Wind-up: Anti-Reset is used to limit the range where integration occurs. This helps in stabilizing a system. With Anti-Reset at 100%, integration will occur throughout the proportional band. With Anti-Reset set to 90%, integration will occur at 90% of the band above the setpoint and 90% of the band below the setpoint. Autotuning automatically sets Ar. Setting range: 0-100% of full scale, set in E.U.

LoC **Lock-out:** This function enables or disables changing the settings of parameters.
 Code:
 0 - All parameter settings are changeable
 1 - All parameter settings are locked; cannot be changed
 2 - Only the main setpoint can be changed; all other parameter settings are locked and cannot be changed.

STAT **Ramp/Soak Status:** The Ramp/Soak program automatically changes the setpoint value with time in accordance with a preset pattern, as shown in the figure below. This device allows a maximum of four ramp and four soak segments. Ramp is the region in which SV changes toward the target value. Soak is the region in which the target value is maintained. STAT displays the current ramp/soak status. No setting can be made.
 oFF: Not in operation
 1-rP – 4-rP: Executing 1st – 4th ramp
 1-St – 4-St: Executing 1st – 4th soak
 End: End of program

SV-1 **Ramp Target Value:** Sets the target value for each ramp to to segment.
SV-4 Setting range: 0-100% of full scale

TM1r **Ramp Segment Time:** Sets the duration of each ramp to to segment.
TM4r Setting range: 00.00 to 99hrs 59mins.

TM1S **Soak Segment Time:** Sets the duration of each soak to to segment.
TM4S Setting range: 00.00 to 99hrs 59mins.

Mod **Ramp/Soak Mode:** Up to 16 different modes of ramp/soak operations are possible. Choose the appropriate code from the Table of Ramp/Soak Modes.
 Setting: 0-15

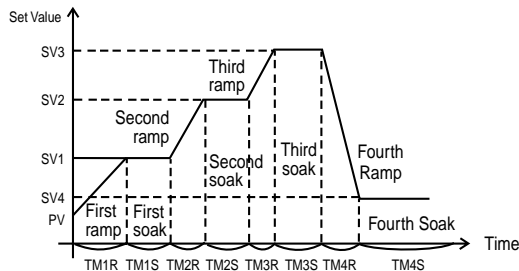

Ramp: Region in which the setpoint changes toward the target value.
Soak: Region in which the setpoint stays unchanged at the target value.

Note 1: SV cannot be changed while the operation is running or suspended.
Note 2: The use of fuzzy control is inhibited while Ramp-Soak operation is being performed.

Table of Ramp/Soak Modes

MOD	Power on start	Output on END	Output on OFF	Repeat function
0	No	Going on control	Going on control	No
1	No	Going on control	Going on control	Yes
2	No	Going on control	Stand-by mode	No
3	No	Going on control	Stand-by mode	Yes
4	No	Stand-by mode	Going on control	No
5	No	Stand-by mode	Going on control	Yes
6	No	Stand-by mode	Stand-by mode	No
7	No	Stand-by mode	Stand-by mode	Yes
8	Yes	Going on control	Going on control	No
9	Yes	Going on control	Going on control	Yes
10	Yes	Going on control	Stand-by mode	No
11	Yes	Going on control	Stand-by mode	Yes
12	Yes	Stand-by mode	Going on control	No
13	Yes	Stand-by mode	Going on control	Yes
14	Yes	Stand-by mode	Stand-by mode	No
15	Yes	Stand-by mode	Stand-by mode	Yes

- Power on Start:** Program starts from the current PV value.
 In non-power-on-start the program starts from the main SV value.
 - Output on END:** Output condition at the end of the program (ProG=End)
 - Output on OFF:** Output condition when program is terminated (ProG=oFF)
 - Repeat function:** Ramp-soak program operates repeatedly.
 If the repeat function is off, the SV value on the last step is maintained.
- Stand-by mode:** Output -3%, Alarm off.
Going on Control: When program ends (End), control is at the SV value on the last step.
 When program is terminated (oFF), control is at the main SV value.

SECONDARY MENU SETTINGS

P-n1 P-n1 Control Action & Sensor Burn-out Protection: The Control Action is the direction of the output relative to the process variable. The PXZ can be programmed as either a reverse or direct acting controller. As a reverse acting controller, the PXZ's output decreases as the process variable increases. A heating application would require reverse acting control. As a direct acting controller, the PXZ's output increases as the process variable increases. A cooling application would require direct acting control. Enter the code from the Table of Output Type Codes which establishes the PXZ as either a reverse or direct acting controller.

The Sensor Burn-out Protection is the intended direction of the output in the event of a thermocouple or RTD sensor break, or a break in the analog input. The PXZ can be programmed with either upper-limit or lower-limit burn-out direction. With Upper-limit Burn-out, a 100% output will be delivered in the event of a sensor burn-out. With Lower-limit Burn-out, 0% output will be delivered in the event of a sensor burn-out. Enter the appropriate code from the Table of Output Type Codes.

Refer to Error Messages on page 15 for more details.

Table of Output Type Codes

Code	Output type	Control action		Burn-out direction	
		Output 1	Output 2	Output 1	Output 2
0	Single	Reverse action	---	Lower limit	---
1				Upper limit	---
2		Direct action	---	Lower limit	---
3				Upper limit	---
4	Dual	Reverse action	Direct action	Lower limit	Lower limit
5				Upper limit	Upper limit
6				Lower limit	Upper limit
7				Upper limit	Upper limit
8				Lower limit	Lower limit
9				Upper limit	Lower limit
10		Direct action	---	Lower limit	Upper limit
11				Upper limit	Upper limit
12				Lower limit	Lower limit
13		Reverse action	Reverse action	Upper limit	Upper limit
14				Lower limit	Upper limit
15				Upper limit	Upper limit
16				Lower limit	Lower limit
17				Upper limit	Lower limit
18				Direct action	---
19		Upper limit	Upper limit		

P-n2 P-n2 Input type: The Input Type is the type of sensor to be used with the PXZ controller in sensing the process variable. The Input Type must be correctly programmed into the controller in order for the controller to perform with the selected sensor type. Depending on the type of sensor to be used, the PXZ comes in two models. One model accepts J, K, R, B, S, T, E, N thermocouples and RTDs (Pt100). The other model accepts 1-5/0-5V DC and 4-20/0-20mA DC signals.

The current/voltage model comes with a 250Ω precision resistor. Wired directly to the controller, it would convert a current signal into a voltage signal. There is no need to use the resistor if a voltage signal is applied directly.

After the appropriate physical changes have been made, the controller still needs the correct code for the Input Type to be used. Enter the appropriate code.

P-dF P-dF Input Filter Constant: The Input Filter is used to filter out the quick changes that occur to the process variable in a dynamic or quick responding application which makes the PXZ control erratically. By slowing down the response time, the PXZ controller averages out the peaks and valleys of a dynamic system which, in turn, stabilizes the control. The Digital Filter also aids the PXZ in controlling processes where the electrical noise is affecting the input signal. The larger the value entered, the more filter added and the slower the controller reacts to process variable changes. The smaller the value entered, the less filter added and the quicker the controller reacts to process variable changes. Enter as small a value as possible at which the PXZ maintains accurate and stable control. Setting range: 0.0-900.0 secs

Table of Input Type Codes

Input Signal		Code	Range of measurement (°C)	Range of measurement (°F)	With decimal point (°C)	With decimal point (°F)
RTD (IEC)	Pt100Ω	1	0 to 150	32 to 302	O	O
	Pt100Ω	1	0 to 300	32 to 572	O	O
	Pt100Ω	1	0 to 500	32 to 932	O	O
	Pt100Ω	1	0 to 600	32 to 1112	O	X
	Pt100Ω	1	-50 to 100	-58 to 212	O	O
	Pt100Ω	1	-100 to 200	-148 to 392	O	O
	Pt100Ω	1	-150 to 600	-238 to 1112	O	X
	Pt100Ω	1	-150 to 850	-238 to 1562	X	X
	Thermocouple	J	2	0 to 400	32 to 752	O
J		2	0 to 800	32 to 1472	O	X
K		3	0 to 400	32 to 752	O	O
K		3	0 to 800	32 to 1472	O	X
K		3	0 to 1200	32 to 2192	X	X
R		4	0 to 1600	32 to 2912	X	X
B		5	0 to 1800	32 to 3272	X	X
S		6	0 to 1600	32 to 2912	X	X
T		7	-199 to 200	-328 to 392	O	X
T		7	-150 to 400	-238 to 752	O	X
E		8	-0 to 800	32 to 1472	O	X
E		8	-199 to 800	-328 to 1472	O	X
N		12	0 to 1300	-32 to 2372	X	X
DC current/voltage	0-20mA/ 0-5V	15	-1999 to 9999 (Scaling is possible)		O= Enabled X=Disabled	
	4-20mA/ 1-5V	16				

P-SL P-SL Lower Limit of Input Range:
P-SU P-SU Upper Limit of Input Range: The Lower Limit and the Upper Limit of Input Range establish the desired high and low limit for the type of input used. The Lower limit must be greater than or equal to the input type's lower limit, while the Upper Limit must be less than or equal to the input type's upper limit. Setpoint settings are restricted to values between P-SL and P-SU.

Parameter values that are calculated as a percentage of full scale are affected by these settings. An under-scale or an overscale error is indicated if the process value goes below or above the range by 5% of full scale. The primary purpose of these parameters when used with thermocouple or RTD inputs is to limit setpoint settings. When an analog input is used, the signal is scaled for the engineering unit range selected. For example, when a 4-20 mA input is used, the value of P-SL corresponds to 4mA and the value of P-SU corresponds to 20 mA.

The engineering unit range could be %, PSI, pH, or any range which can be scaled between -1999 and 9999 units.

Refer to the Table of Input Type Codes above to determine the measuring range for a particular input type.

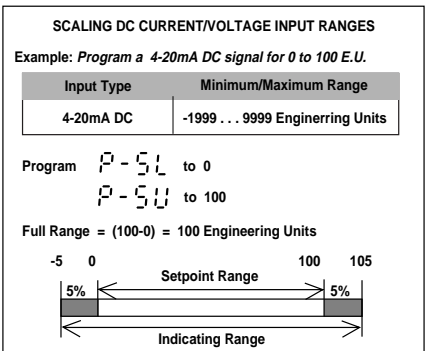
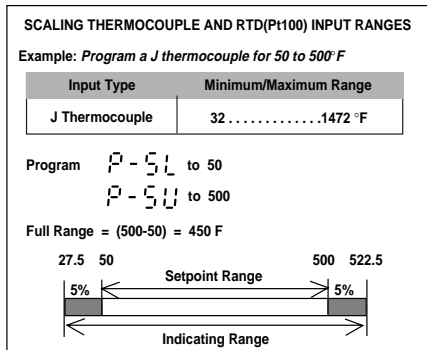

P-AL P-AL Alarm Type 2:

P-AH P-AH Alarm Type 1: This function sets the control action for the optional alarm output relays. The PXZ5, 7, and 9 comes with two relays while the PXZ4 comes with one. They can be programmed for absolute, deviation, combination, or zone alarm configuration. The high and low alarm setpoints are set with primary menu parameters AH and AL. The absolute alarm configurations are independent of main setpoint. The alarm output relays are energized when the process variable exceeds the alarm setpoint, an absolute value. The deviation alarm configuration is main setpoint tracking. The alarm output relays are energized when the process variable exceeds the main setpoint by a deviation value set by AL or AH. The combination alarm configurations are a mixture of both the deviation and absolute value settings for the high and low alarms. With zone alarm configurations the alarm output is energized between the range set by AL and AH. One of the alarm types is Alarm with Hold. In this case the alarm is not turned on the first time the measured value is in the alarm band. Instead it turns on only when the measured value goes out of the band and enters it again. This type is useful when using deviation alarm with step type input. Enter the code for P-AH and P-AL from the Table of Alarm Action Type Codes.

Note 1: A change of alarm action type can cause the alarm set value to change, but this is not a malfunction.
Note 2: After the alarm type is changed, turn off the power to the unit once.

Table of Alarm Action Type Codes

	ALM1 (P-AH)	ALM2 (P-AL)	Alarm type	Action diagram
	0	0	No alarm	
Absolute value alarm	1	1	High alarm	
	2	2	Low alarm	
	3	3	High alarm (with hold)	
	4	4	Low alarm (with hold)	
Deviation alarm	5	5	High alarm	
	6	6	Low alarm	
	7	7	High/Low alarm	
	8	8	High alarm (with hold)	
	9	9	Low alarm (with hold)	
	10	10	High/Low alarm (with hold)	
Zone alarm	11	11	High/Low deviation alarm (ALM 1/2 independent action)	
	—	12	High/Low absolute alarm	
	—	13	High/Low deviation alarm	
	—	14	High absolute/ Low deviation alarm	
	—	15	High deviation/ Low absolute alarm	

P-AH P-AH Alarm Hysteresis: The Alarm Hysteresis is that area on one side of the alarm setpoint where the output does not change condition. That area or deadband is intended to eliminate relay chatter at alarm setpoint with less wear on the relay. With a wide Alarm Hysteresis, the controller takes a longer time to change output condition. With a narrow Alarm Hysteresis, the controller takes a short time to change output condition. Enter a value which is just large enough to eliminate relay chatter. Setting Range: 0 to 50% of full scale, set in E.U.

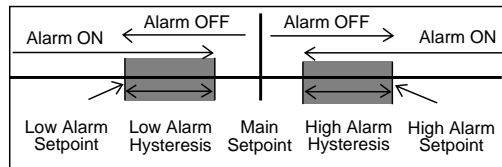

P-D P-D Decimal Point Position (Resolution): The Decimal Point Position is the resolution at which the PXZ controller displays the process variable and other parameter values. The PXZ can indicate integers, tenths or hundredths of a unit. The Decimal Point Position does not increase the accuracy of the controller, it only increases the resolution. For a thermocouple, integers are usually sufficient due to the accuracy rating and the programmed input range. For a RTD (Pt100), integers or tenths of a degree may be entered, because of the increased accuracy of these sensors, depending on the programmed input range. For a 1-5/0-5V DC or 4-20/0-20mA DC signal, integers, tenths or hundredths of a unit may be entered depending on the pro-

grammed input range.
The input range can be anywhere between -1999 and 9999 units and must be programmed in the lower limit of input range and the upper limit of input range parameters with decimal place values. Enter a Decimal Point Position code dependent on the desired resolution, the input type, and the programmed input range.
Setting:

- 0 -None
- 1- Tenths of a unit
- 2 - Hundredths of a unit

PVOF PVOF Process Variable Offset: The Process variable Offset is the amount by which the indicated process variable is shifted in a positive or negative direction. Both the indicated as well as the measured process variable will be changed. This parameter can be used to correct for differences in sensors, sensor placement, and standardization problems. Enter a value which is the difference between the measured process value and the actual process value of the system.
Setting range: -10 – 10% of full scale, set in Eng. units

SVOF SVOF Setpoint Variable Offset: The Setpoint Variable Offset is that amount of offset which shifts the measured setpoint variable in a positive or negative direction. The measured setpoint variable is changed but the indicated setpoint variable remains unchanged. Be careful when using this variable because what you see as the setpoint variable may be very different from the actual setpoint variable.
Setting range: -50 – 50% of full scale, set in Eng. units
Indicated Setpoint Variable is Unchanged
Measured Setpoint Variable is Changed

P-F P-F C/F Selection: The C/F Selection is that function which scales the process variable and other setting variables to either the Celsius or Fahrenheit scale. If using the controller to control a process other than temperature using the current/voltage input model, the C/F Selection is not important because the scaling is done using the lower limit of the input range and upper limit of input range parameters. If using the thermocouple/RTD (Pt100) input model, however, the C/F Selection is important in scaling the controller's parameters.
Setting: °C or °F

FUZY FUZY Fuzzy Logic Control: Employing Fuzzy Logic Control in addition to PID control eliminates system overshoot and effectively suppresses fluctuation of the process variable due to external disturbances. This function may be enabled even during auto-tuning. Note that fuzzy control is not effective in units with dual outputs, due to the complexity of the process. Fuzzy control is also inhibited while the Ramp/Soak function is in operation.

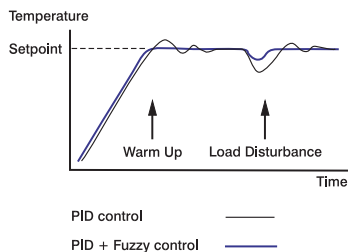

ADJO ADJO Input Calibration: This function is used for input calibration by the user in a simple manner. Calibration is effected by applying signal for zero and span points of the input range being used and then by setting errors. The user calibration function is an independent function and the instrument can easily be reset to conditions prior to delivery.

Example:

Input range 0-400°C

Indication at 0°C : -1°C

Indication at 400°C: 402°C

Change ADJO to 1 and ADJS to -2 to correct the error. The instrument can be set back to factory values by setting ADJO and ADJS to 0.

dSP1 dSP1 Parameter Mask function: This function is used to individually mask the display of parameters that are not used for your application, or parameters that are not to be accessed by the operator. To mask or unmask a parameter appropriate values should be selected from the DSP Assignment table.

Example 1: To mask parameter P

1) Determine the dSP value for P from the Quick Reference guide. P = dSP1 – 2

2) Add 2 to the existing dSP1 value.

Example 2: To display/unmask the parameter P-F

1) Determine the dSP value for P-F from the Quick Reference guide. P-F = dSP6 – 64

2) Subtract 64 from the existing dSP6 value.

ERROR MESSAGES

Error Indication	Cause	Control Output
UUUU	1. Thermocouple burnt out. 2. RTD (A) leg burnt out. 3. PV value exceeds P-SU by 5% FS.	When the burn-out control output is set for lower limit (standard): OFF, or 4mA or less.
LLLL	1. When RTD (B or C) is burnt out. 2. When RTD (between A and B, or between A and C) is shorted. 3. When PV value is below P-SL by 5% FS. 4. When analog input wiring is open or short.	When the burn-out control output is set for upper limit: ON, or 20mA or less.
LLLL	When PV value goes below -1999.	Control is continued the value reaches -5% FS or less, after which burn-out condition will occur.
HB lamp ON	Heater break condition	Normal control output for heating is continued.
Errr	When the setting of P-SL/P-SU is improper	OFF, or, 4mA or less.
FAULT	Fault in the unit	Undefined. Stop use immediately.

APPENDIX A

Autotuning

By autotuning, the controller selects what it calculates to be the optimal PID control parameters for a particular process and then stores them in EEPROM memory for future use. The PID parameters are stored so that when the controller is powered up after being shut down, the controller does not need to be autotuned again. The PXZ uses the same autotuned PID parameters until the Autotune function is again initiated. The Autotune parameters are only good for the process the Autotune function was used on. If the setpoint is significantly changed, the input sensor is changed, the load or output device is changed or relocated, or any other disturbances occur which might change the dynamics of the system, the Autotune function should be performed again. The autotuned control parameters are not always perfect for every application but almost always give the operator a good starting point from which further refinement of the control parameters can be performed manually.

The PXZ's autotuning algorithm is particularly suited for temperature control applications and may not always autotune effectively for other processes. Here are cases where the Autotune function does not perform well or does not perform at all:

1. The system is affected by process disturbances external to the control loop. Adjacent heater zones, changing material levels, exothermic reactions are examples of process disturbances which are external to the control loop. The PXZ would never be able to autotune such an unstable process.
2. The system is very dynamic. The process variable changes very quickly. Certain pressure and flow applications would be characterized as very dynamic. Because of how the Autotune function is performed, a very dynamic system would create very large overshoots which could damage the process.
3. The system is very insulated and cannot cool down in a timely manner. With such heating systems the autotuning function would take a very long time to complete with questionable results.

In Autotune, the PXZ sends test signals to the process. The test signals are 100% output and 0% output at the Autotune point. The Autotune point can either be at setpoint or 10% of full scale below setpoint.

The controller performs as an On/Off controller. See diagram below.

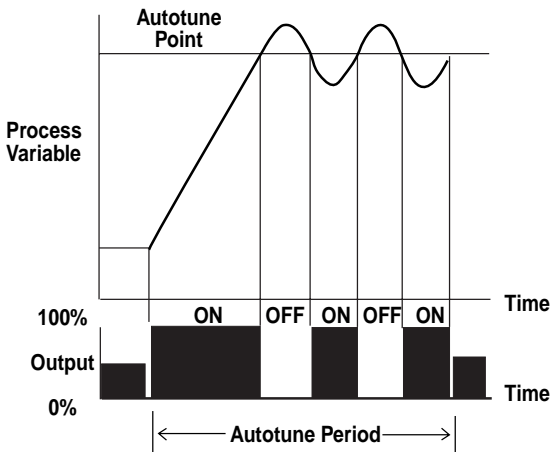

The PXZ then reads the reaction of these test signals on the process. Keep in mind that every process is different and therefore every reaction to the test signals is different. This is why PID parameters are not the same for different processes. The amplitude (L) or lag time which is the overshoot and undershoot of the system when autotuning and the time constant (T) which is the time the process takes to go through one On/Off cycle is measured. See diagram below.

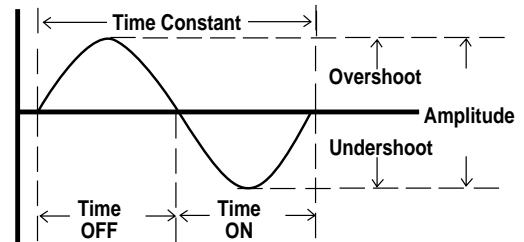

The measurements are then used with the Autotune algorithm for calculation of the proper PID parameters for the system. See the PXZ Autotune algorithm below, where K is the proportionality constant and S is the Laplace operator.

$$\frac{K}{(1+TS)} e^{-LS}$$

APPENDIX B

Manual Tuning

Tune the PXZ controller if any of the following occurs:

- PXZ is installed in a new system
- PXZ is used as a replacement in an existing system
- The input sensor is relocated or changed
- The output device is relocated or changed
- The setpoint is significantly changed
- Any other condition that will alter the dynamics of the system

Proportional Band

The proportional band is a band around the setpoint of the PXZ where the output is between 0% and 100%. The percentage of output is proportional to the amount of error between the setpoint variable (SV) and the process variable (PV). Outside of the proportional band the output is either 0% or 100%.

The proportional band on the PXZ is equidistant from the main setpoint as illustrated below.

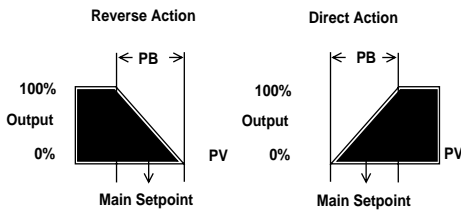

Note: PB = Proportional Band

An example of proportioning would be a vehicle approaching a stop sign at an intersection. If the driver were traveling at 50mph and only applied his brakes once at the intersection, his car would skid through the intersection before coming to a full stop. This illustrates how On/Off control acts. If, however, the driver started slowing down some distance before the stop sign and continued slowing down at some rate, he could conceivably come to a full stop at the stop sign. This illustrates how proportional control acts. The distance where the speed of the car goes from 50 to 0 MPH illustrates the proportional band. As you can see, as the car travels closer to the stop sign, the speed is reduced accordingly. In other words, as the error or distance between the car and the stop sign becomes smaller, the output or speed of the car is proportionally diminished. Figuring out when the vehicle should start slowing down depends on many variables such as speed, weight, tire tread, and braking power of the car, road conditions, and weather much like figuring out the proportional band of a control process with its many variables.

The width of the proportional band depends on the dynamics of the system. The first question to ask is, how strong must my output be to eliminate the error between the setpoint variable and process variable? The larger the proportional band (low gain), the less reactive the process. A proportional band too large, however, can lead to process wandering or sluggishness. The smaller the proportional band (high gain), the more reactive the output becomes. A proportion-

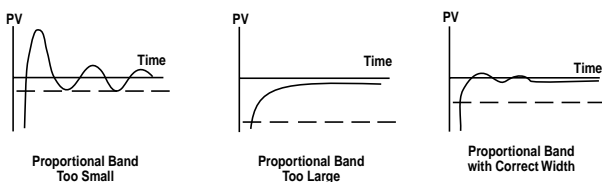

al band too small, however, can lead to over-responsiveness leading to process oscillation.

A proportional band which is correct in width approaches main setpoint as fast as possible while minimizing overshoot. If a faster approach to setpoint is desired and process overshoot is not a problem, a smaller or narrower proportional band may be used. This would establish an over-damped system or one where the output would change greatly, proportional to the error. If process overshoot cannot be tolerated and the approach to setpoint does not have to be quick, a larger or wider proportional band may be used. This would establish an under-damped system or one where the output would change little, proportional to the error.

To Calculate Proportional Band:

$$\text{Proportional Band (as a percentage)} = \frac{\text{Proportional Band}}{\text{Input Range}} \times 100\%$$

Example:

$$3\% = \frac{30^\circ\text{C}}{100^\circ\text{C}} \times 100\%$$

$$\text{Proportional Band Range} = \frac{\text{Proportional Band (as a percentage)}}{100\%} \times 1000^\circ\text{C}$$

Example:

$$30^\circ\text{C} = \frac{3\%}{100\%} \times 1000^\circ\text{C}$$

Integral Time

With the proportional band alone, the process tends to reach equilibrium at some point away from the main setpoint. This offset is due to the difference between the output needed to maintain setpoint and the output of the proportional band at setpoint. In the case of the PXZ controller where the proportional band is equidistant from the main setpoint, the output is around 50%. If anything more or less than 50% output is required to maintain setpoint, an offset error will occur. Integral action eliminates this offset. See the diagrams below.

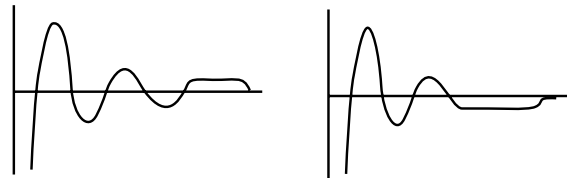

Integral action eliminates offset by adding to or subtracting from the output of the proportional action alone. This increase or decrease in output corrects for offset error within the proportional band in establishing steady-state performance at setpoint. It is not intended to correct for process disturbances. See the following diagram.

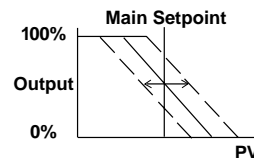

Integral Time is the speed at which the controller corrects for offset. A short integral time means the controller corrects for offset quickly. If the integral time is too short, the controller would react before the effects of previous output shifts, due to dead time or lag, could be sensed causing oscillation. A long Integral time means the control corrects for offset over a long time. If the integral time is too long, the offset will remain for some time causing slow responding or sluggish control. See the diagram below.

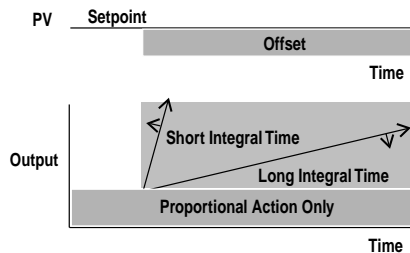

Derivative Time

In the case of a process upset, proportional only or proportional-integral action cannot react fast enough in returning a process back to setpoint without overshoot. The derivative action corrects for disturbances providing sudden shifts in output which oppose the divergence of the process from setpoint. See the diagram below.

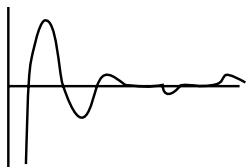

The derivative action changes the rate of reset or integration proportional to the rate of change and lag time of the system. By calculating the rate of change of the process and multiplying it by the lag time which is the time it takes the controller to sense an output change, the controller can anticipate where the process should be and change the output accordingly. This anticipatory action speeds up and slows down the effect of proportional only and proportional-integral actions to return a process to setpoint as quickly as possible with minimum overshoot. See the diagram below.

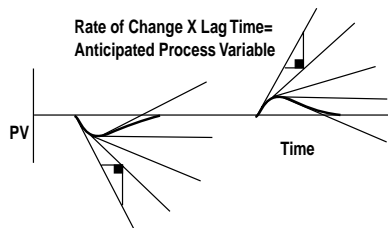

Derivative time is the amount of anticipatory action needed to return a process back to setpoint. A short derivative time means little derivative action. If the derivative time is too short, the controller would not react quickly to process disturbances. A long derivative time means more derivative action. If the derivative time is too large, the controller would react too dramatically to process disturbances creating rapid process oscillation. A process which is very dynamic such as pressure and flow applications is more efficiently controlled if the derivative action is turned off because of the oscillation problem which would result.

Tuning

Tuning the PXZ, as with any PID loop, requires tuning each parameter separately and in sequence. To achieve good PID control manually, you can use the trial and error method explained below.

Tune the Proportional Band

Set Integral Time = 0 (off)

Set Derivative Time = 0 (off)

Start with a large Proportional Band value which gives very sluggish control with noticeable offset and tighten by decreasing the value in half. Analyze the process variable. If the control is still sluggish, tighten by decreasing the value in half again. Continue with the same procedure until the process starts to oscillate at a constant rate. Widen the Proportional Band by 50%, or multiply the setting 1.5 times. From a cold start, test and verify that the Proportional Band allows maximum rise to setpoint while maintaining minimum overshoot and offset. If not completely satisfied, fine-tune the value, up or down, as needed and test until correct. The Proportional Band is now tuned.

Add Integral Time

Start with a large Integral Time value which gives very sluggish response to process offset and tighten by decreasing the value in half. Analyze the process variable. If the response to process offset is still sluggish, tighten by decreasing the value in half again. Continue with the same procedure until the process starts to oscillate at a constant rate. Increase the Integral Time value by 50%, or multiply the setting 1.5 times. From a cold start, test and verify that the Integral Time allows maximum elimination of offset with minimum overshoot. If not completely satisfied, fine-tune the value, up or down, as needed and test until correct. The Integral Time is now tuned.

Add Derivative Time

Do not add Derivative Time if the system is too dynamic. Start with a small Derivative Time value which gives sluggish response to process upsets and double the value. Analyze the process variable. If the response to process upsets is still sluggish, double the value again. Continue with the same procedure until the process starts to oscillate at a quick constant rate. Decrease the Derivative Time value by 25%. From a cold start, test and verify that the Derivative Time value allows maximum response to process disturbances with minimum overshoot. If not completely satisfied, fine-tune the value, up or down, as needed and test until correct. Note that the Derivative Time value is usually somewhere around 25% of the Integral Time value.

Another tuning method is the closed-loop cycling or Zeigler-Nichols method. According to J.G. Zeigler and N.B. Nichols, optimal tuning is achieved when the controller responds to a difference between setpoint and the process variable with a 1/4 wave decay ratio. That is to say that the amplitude of each successive overshoot is reduced by 3/4 until stabilizing at setpoint. The procedure is explained below.

1. Integral Time=0
Derivative Time=0
2. Decrease the Proportional Band to the point where a constant rate of oscillation is obtained. This is the response frequency of the system. The frequency is different for each process.
3. Measure the Time Constant which is the time to complete one cycle of the response frequency. The Time Constant will be defined as "T" when calculating Integral and Derivative Times.

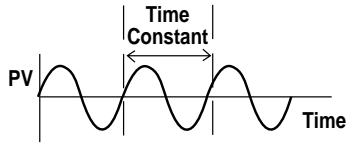

4. Widen the Proportional Band until only slightly unstable. This is the Proportional Band's Ultimate Sensitivity. The Proportional Band's Ultimate Sensitivity width will be defined as "P" when calculating the actual Proportional Band.
5. Use the following coefficients in determining the correct PID settings for your particular application.

Control Action	P Setting	I Setting	D Setting
P Only	2P	*	*
PI	2.2P	.83T	*
PID	1.67P	.5T	.125T

APPENDIX C

Heater Break Option

The Heater Break Option is used to detect heater break conditions and to energize an alarm relay when such conditions exist. In most cases, the option is used to detect the failure of one or more zones in a multi-zoned heater where all individual resistive heater zones are wired in parallel. Failed heater zones would create cold spots in a system which could hamper the process and even ruin the product. If cold spots in a system are a problem, the Heater Break Option is an effective way of alerting the operator of a heater break condition, a cause of cold spots.

The PXZ controller is able to detect a heater problem by analyzing the current used by the heater. The actual sensing is done by a current sensing transformer, sold separately, which is placed around the hot lead going to the heater and connected to the controller. The signal sent by the current sensing transformer is timed with the output of the PXZ. When the output is energized the signal sent from the current sensing transformer is analyzed. When the output is de-energized the signal sent from the current sensing transformer is not analyzed. This eliminates the alarm condition turning on and off due to the output condition of the controller. If the signal sent when the output is energized indicates that the current level is below what the Heater Break alarm is set for, the alarm is energized. The alarm is non-latching.

Notes:

1. The Heater Break Option is available on the PXZ-5, 7, and 9 controllers only.
2. The Heater Break Option cannot be used on the PXZ controller with a 4-20mA DC output. The current sensing transformer would pick up current changes due to fluctuating power output, between 0% and 100%, which would result in a heater break alarm condition even though no such condition existed.
3. The Cycle Time must be set at 6 secs. or higher in order for the controller to correctly analyze the signal sent by the current sensing transformer.
4. The power supply used should be the same for the PXZ and heater to eliminate current fluctuations due to power differences between different power supplies.

Wiring and Setting:

1. Choose the correct current sensing transformer based on the maximum current usage of the heater.
0 - 30 Amps (part # CTL-6-SF)
0 - 50 Amps (part # CTL-12-S36-8F)

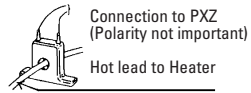

2. Thread the hot lead going to the heater through the donut of the current sensing transformer. Connect the wires of the current sensing transformer to the current sensing transformer input terminals in the back of the controller.
3. Set Heater Break alarm setpoint parameter "Hb". With the current sensing transformer connected and the heater in operation, output energized, change the Heater Break Alarm setting from the maximum current setting for the particular current sensing transformer being used to a lower value. Allow 3 secs. or more between setting changes. Continue lowering the setting until the relay is energized and the "HB" status indicator is lit. This is the maximum current usage of the heater. Using the same procedure, find the maximum current usage of the heater minus one zone. Set the setpoint in between the two current readings. In this way, the operator knows if one or more zones fail because the current sensed will only be below the Heater Break Alarm setting if one or more zones fail.

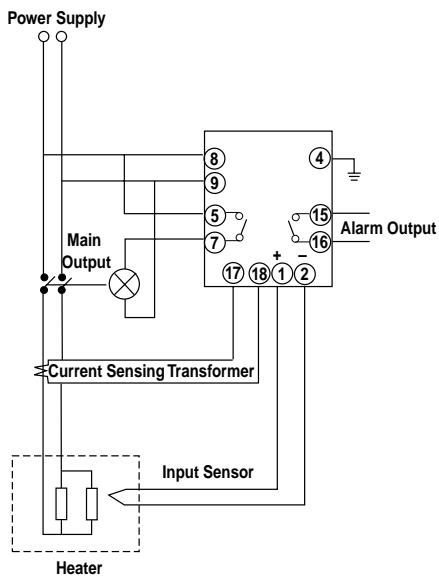

APPENDIX D

Heat/Cool Option

With the Heat/Cool Option, the PXZ can control a temperature application with one input at one main setpoint using two outputs, a heating output and a cooling output. By using a heating and cooling output, a process is able to quickly bring the temperature to setpoint in both directions and to limit the amount of overshoot. The larger the deviation from setpoint, the more output applied to the system on both the heating and cooling sides. Heat/Cool control is a very effective way of controlling exothermic processes, processes that generate their own heat, or processes where ambient temperature is not adequate or fast enough in returning a process back to setpoint.

The two outputs on the PXZ are independent and sent to two different output devices. The PXZ can be equipped with two of the same or two different output types. Output #2 can be relay, SSR/SSC driver, or 4-20mA DC, regardless of what Output #1 is. Both output types must be specified when ordering.

The PXZ controls the cooling side with three additional parameters, TC-2, COOL, and DB. Each is explained below:

TC-2 Cycle Time (Output #2): Because Output #2 is not necessarily the same as Output #1, the cycle time may be different

COOL Proportional Band Coefficient for Cooling: Because the cooling power may not necessarily be the same as the heating power, the cooling proportional band may need to be different from that of the heating proportional band.

db Deadband/Overlap: Deadband is that area where neither outputs are energized. Overlap is that area when both outputs are energized. This function lets you decide where you want the heating action to stop and the cooling action to begin.

Notes:

1. The Heat/Cool Option is available on the PXZ-5, 7, and 9 controllers only. Output #2 type can be the same or different than Output #1 type (Relay, SSR/SSC driver, or 4-20mA DC)
2. Integral and Derivative Times are the same for both the heating and cooling sides of a process with PID control because the response frequency or time constant of the system does not change at main setpoint when cooling is added.
3. The Proportional Band for heating and cooling are almost always different. Rarely does the same amount of cooling output remove the same percentage of process error as the heating output does. The Cooling Proportional Band must be manually and separately tuned.
4. If the heating side is set for On/Off control, the cooling side will be set for On/Off control also. Regardless of what the COOL parameter is set for, if the Proportional Band is set to zero, the Heating Proportional Band and the Cooling Proportional Band will always be zero or On/Off.

5. If the cycle times of one or both outputs are long and the process dynamic, there is a good chance that both outputs will be cycling on and off at the same time around main setpoint. This is evident if one or both outputs are relays.
6. Autotune is not effective on the cooling side of Heat/Cool control. Autotune the controller for heat only and then manually tune the cooling parameters.

Wiring and Setting

1. Make sure that your PXZ has the correct output type installed for Output #2. Verify that the TC2, COOL, and DB parameters are indicated in the primary (setpoint) menu.
2. Wire your cooling load to the Output #2 terminals located on the back of your PXZ controller.
3. In the secondary (system) menu, program the correct code for Heat/Cool action. See page 13 for the complete code table.
4. In the primary (setpoint) menu, program TC2, the cycle time for Output #2. The table below is a general guide to TC2 settings.

Output#2 Type	Setting(Secs)
Relay	30
SSR Driver (pulsed DC)	2
4-20mA DC	Not indicated or 0

5. Autotune or manually tune the PID parameters of your PXZ controller. Autotune will work for the heating PID parameters but not on the cooling parameters. You must manually tune the cooling parameters.

Heating Side	Cooling Side
Heating Proportional Band [P/2]	Cooling Proportional Band [P/2 COOL]
I	I (same as for heating)
D	D (same as for heating)

6. With the heat side tuned, manually set the COOL parameter or Proportional Band Coefficient for Cooling. If the cooling output is less powerful than the heating output, the Cooling Proportional Band must be narrower than the Heating Proportional Band; the COOL parameter would be less than "1". If the cooling output is more powerful than the heating output, the Cooling Proportional Band must be wider than the Heating Proportional Band; the COOL parameter would be more than "1". See the programming section for more details.
7. Finally, you can add a Deadband/Overlap. The programmed Deadband/Overlap parameter can be within -50% to +50% of the Heating Proportional band. To establish a Deadband, parameter "db" is set somewhere between 0% and 50% of the Heating Proportional band. To establish an Overlap, db is set somewhere between -50% and 0% of the Heating Proportional Band.
8. Manually fine-tune the parameters COOL and db until just the right amount of cooling is achieved. Refer to the programming section for more details on these parameters.

PXZ QUICK REFERENCE

Primary Menu

Parameter	Range	Description	Default settings	DSP settings
ProG	ProG	oFF/rUn/HLd	Ramp/soak command	oFF dSP1-1
P	P	0.0 - 999.9%FS	Proportional band	5.0 dSP1-2
I	I	0 - 3200sec	Integral time	240 dSP1-4
D	D	0.0 - 999.9sec	Derivative time	60 dSP1-8
AL	AL	0 - 100%FS	Low Alarm Setpoint	10 dSP1-16
AH	AH	0 - 100%FS	High Alarm Setpoint	10 dSP1-32
TC	TC	1 - 150sec	Cycle Time (output #1)	† dSP1-64
HYS	HYS	0 - 50%FS	Hysteresis	1 dSP1-128
Hb	Hb	0.0 - 50.0A	Heater-break alarm S.P.	0.0 dSP2-1
AT	AT	0 - 2	Auto-tuning command	0 dSP2-2
TC2	TC2	1 - 150sec	Cycle Time (output #2)	† dSP2-4
Cool	Cool	0.0 - 100.0	Proportional band coefficient for cooling	1.0 dSP2-8
db	db	-50.0 - 50.0% FS	Deadband/Overlap	0.0 dSP2-16
PLC1	PLC1	-	N/A	-3.0 dSP2-32
PHC1	PHC1	-	N/A	103.0 dSP2-64
PCUT	PCUT	-	N/A	0 dSP2-128
bAL	bAL	0 - 100%	Balance	0.0/50.0 dSP3-1
Ar	Ar	0 - 100%FS	Anti-reset windup	100%FS dSP3-2
LoC	LoC	0 - 2	Lock out	0 dSP3-4
STAT	STAT	--	Ramp/soak status	oFF dSP3-8
SV1	SV-1	0 - 100%FS	1st S.P.	0%FS dSP3-16
TM1r	TM1r	0 - 99hr 59min	1st ramping time	0.00 dSP3-32
TM1S	TM1S	0 - 99hr 59min	1st soaking time	0.00 dSP3-64
SV2	SV-2	0 - 100%FS	2nd S.P.	0%FS dSP3-128
TM2r	TM2r	0 - 99hr 59min	2nd ramping time	0.00 dSP4-1
TM2S	TM2S	0 - 99hr 59min	2nd soaking time	0.00 dSP4-2
SV3	SV-3	0 - 100%FS	3rd S.P.	0%FS dSP4-4
TM3r	TM3r	0 - 99hr 59min	3rd ramping time	0.00 dSP4-8
TM3S	TM3S	0 - 99hr 59min	3rd soaking time	0.00 dSP4-16
SV4	SV-4	0 - 100%FS	4th S.P.	0%FS dSP4-32
TM4r	TM4r	0 - 99hr 59min	4th ramping time	0.00 dSP4-64
TM4S	TM4S	0 - 99hr 59min	4th soaking time	0.00 dSP4-128
Mod	MOD	0 - 15	Ramp/Soak Mode code	0 dSP5-1

PXZ QUICK REFERENCE

Secondary Menu

Parameter	Range	Description	Default settings	DSP settings
P-n1	P-n1	0 - 19	Control Action code	† dSP5-4
P-n2	P-n2	0 - 16	Input type code	† dSP5-8
P-dF	P-dF	0.0 - 900.0sec	Input filter constant	5.0 dSP5-16
P-SL	P-SL	-1999 - 9999	Lower range of input	0%FS dSP5-32
P-SU	P-SU	-1999 - 9999	Upper range of input	100%FS dSP5-64
P-AL	P-AL	0 - 15	Alarm Type 2 code	9 dSP5-128
P-AH	P-AH	0 - 11	Alarm Type 1 code	5 dSP6-1
P-An	P-An	0 - 50%FS	Alarm Hysteresis	1 dSP6-2
P-dP	P-dP	0 - 2	Decimal point position	0 dSP6-4
rCJ	rCJ	-	-	ON dSP6-8
PVOF	PVOF	-10 - 10%FS	PV offset	0 dSP6-16
SVOF	SVOF	-50 - 50%FS	SV offset	0 dSP6-32
P-F	P-F	°C/°F	°C/°F Selection	† dSP6-64
PLC2	PLC2	-	N/A	-3.0 dSP6-128
PHC2	PHC2	-	N/A	103.0 dSP7-1
FUZY	FUZY	OFF/ON	Fuzzy control	OFF dSP7-2
GAIN	GAIN	-	N/A	1 dSP7-4
ADJO	ADJO	-	Zero calibration	0 dSP7-8
ADJS	ADJS	-	Span calibration	0 dSP7-16
OUT	OUT	-	N/A	-3.0 dSP7-32
dSP1	dSP1-7	0-255	Parameter mask	† -

† Based on the model

530B CONTROL SERIES

DART

CONTROLS

Instruction Manual

Variable Speed DC Control



**P.O. Box 10
5000 W. 106th Street
Zionsville, Indiana 46077**

**Phone (317) 873-5211
Fax (317) 873-1105
www.dartcontrols.com**

TABLE OF CONTENTS

WARRANTY	1
INTRODUCTION	2
COMMONLY ASKED QUESTIONS	2
BASIC MODEL SELECTION	2
CONTROL FEATURES	3
OVERALL CONTROL DIMENSIONS	3-4
SPEEDPOT MOUNTING DIMENSIONS	4
MOUNTING INSTRUCTIONS	4
WIRING PROCEDURE	4
TERMINAL STRIP WIRING - P1	5
TERMINAL STRIP WIRING - P2	5-6
SETTING INPUT VAC	6
SWITCH LADDER CIRCUIT DIAGRAMS	6
“RE” CONTROL PANEL IDENTIFICATION	6
INITIAL START-UP	7
TRIMPOT ADJUSTMENT PROCEDURE	7-8
TRIMPOT SETTING CHART	8
1.5 AND 3.0 HORSEPOWER - MODEL 533BC	8
BASIC HOOK-UP DIAGRAM WITHOUT OPTIONS	9-10
530BC, 533BC & 530BRC HOOK-UP DIAGRAMS	9
PILOT RELAY SWITCHING	9
530BRE HOOK-UP DIAGRAM	10
JU2 JUMPER WIRE SELECTION CHART	10
CONTROL MODIFICATIONS	10-11
TWO SPEED OPERATION	10
DYNAMIC BRAKING	10
TACHOMETER FEEDBACK & FOLLOWER	11
INHIBIT INSTRUCTIONS	11
OPTIONS	11-15
-4 OPTION	11
-5 OPTION	12
-7 / -11 / -15A OPTIONS	13
-36M / -38M OPTIONS	14-15
IN CASE OF DIFFICULTY	15
FUSING	15
SPECIFICATIONS	16
530B SERIES PARTS PLACEMENT & LIST	17
530B SERIES SCHEMATIC	18
PRODUCT LINE	BACK COVER

WARRANTY

Dart Controls, Inc. (DCI) warrants its products to be free from defects in material and workmanship. The exclusive remedy for this warranty is DCI factory replacement of any part or parts of such product which shall within 12 months after delivery to the purchaser be returned to DCI factory with all transportation charges prepaid and which DCI determines to its satisfaction to be defective. This warranty shall not extend to defects in assembly by other than DCI or to any article which has been repaired or altered by other than DCI or to any article which DCI determines has been subjected to improper use. DCI assumes no responsibility for the design characteristics of any unit or its operation in any circuit or assembly. This warranty is in lieu of all other warranties, express or implied; all other liabilities or obligations on the part of DCI, including consequential damages, are hereby expressly excluded.

NOTE: Carefully check the control for shipping damage. Report any damage to the carrier immediately. Do not attempt to operate the drive if visible damage is evident to either the circuit or to the electronic components.

All information contained in this manual is intended to be correct, however information and data in this manual are subject to change without notice. DCI makes no warranty of any kind with regard to this information or data. Further, DCI is not responsible for any omissions or errors or consequential damage caused by the user of the product. DCI reserves the right to make manufacturing changes which may not be included in this manual.

WARNING

Improper installation or operation of this control may cause injury to personnel or control failure. The control must be installed in accordance with local, state, and national safety codes. Make certain that the power supply is disconnected before attempting to service or remove any components!!! If the power disconnect point is out of sight, lock it in disconnected position and tag to prevent unexpected application of power. Only a qualified electrician or service personnel should perform any electrical troubleshooting or maintenance. At no time should circuit continuity be checked by shorting terminals with a screwdriver or other metal device.

INTRODUCTION

The 530B Series is a high performance, dual voltage versatile DC motor control which provides a wide range of standard features, with many options that extend its capabilities. The 530B Series will operate 1/8 through 1.0 horsepower at 115VAC input, and 1/4 through 2.0 horsepower at 230VAC input. A chassis only model is available to operate a 1.5 horsepower motor at 115VAC input, or 3.0 horsepower at 230VAC input. Reference "Basic Model Selection" guide.

The 530B Series consists of three basic types:

- C** = Chassis mounted, no enclosure, no power relay's.
- RC** = Chassis mounted, no enclosure, with power relay's.
- RE** = Plastic enclosure with power relay's - Nema 4/12 standard.

The 530B Series is designed for Permanent Magnet, Shunt Wound, and some Universal Series (AC/DC) motors in the above horsepower ranges. The 530B Series incorporates transient voltage protection with adjustable Current Limit and AC fuses for protection. Minimum and Maximum speeds are easily adjusted by trimpots, as is the I.R. Compensation. Acceleration and Deceleration are fully adjustable via individual trimpots.

COMMONLY ASKED QUESTIONS

- Q. Can I run two or more motors from the same drive?**
A. Not recommended. The I.R. Compensation (regulation) and Current Limit circuits would have difficulty sensing the different load on each motor.
- Q. Can I change the horsepower of my motor and still use the same control?**
A. Yes, provided you do not deviate outside the horsepower range for the voltage you are using. The trimpots would need readjustment; see "Trimpot Chart" for approximate settings.
- Q. Can I use the 530B Series as a Current Follower?**
A. Yes, there is a field installable -5 or -7 option shown in "Options" section.
- Q. Can I use the 530B Series on Tachometer feedback?**
A. Yes, see +Tach (P2-9) under "Terminal Strip Wiring - P2".
- Q. Can I use the Stop (P2-11), Start (P2-13), and Common (P2-12) to stop-start the control on the "C" chassis version?**
A. No. Terminals P2-11, P2-12, and P2-13 are only active on the relay versions; "RE" and "RC". These terminals are non-operative on the "C" version.
- Q. Can the 530B Series be used as a Voltage or Tachometer Follower?**
A. Yes. The voltage must be ungrounded and no more than +12 VDC (See "Terminal Strip Wiring" for proper hook-up).
- Q. How would I proceed to stop/start the 530B Series with my own relay?**
A. You can use the contact of your relay in place of the AMP REF to REV 1 (P2-2 to P2-7) jumper wire. Since this is a low level signal (12 volts at 2mA), you must use a logic type relay (preferably gold contacts). This cannot be done on controls using some options. Consult your Dart Representative if options are involved.
- Q. Why is a jumper wire between AMP REF (P2-2) and REV 1 (P2-7) needed on drives with no options?**
A. REV 1 (P2-7) and REV 2 (P2-8) are two identical stop inputs. One of these must be held low (to Amp Ref P2-2) for the control to run. If the drive has no options, this must be jumpered to satisfy the "OR" gate. This requirement is satisfied by some options. For these options, a connection must be made to these terminals. Instead of a jumper wire, the option is wired to these terminals. (See "Jumper Wire Selection").

BASIC MODEL SELECTION

<i>115/230 VAC INPUT 0-90/0-180 VDC OUTPUT 100/200 VDC FIELD</i>			
HP RANGE ¹	CHASSIS	RELAY CHASSIS	RELAY ENCLOSED
1/8 - 2.0	530BC	530BRC	530BRE
<i>115/230 VAC INPUT 0-90/0-180 VDC OUTPUT 100/200 VDC FIELD</i>			
HP RANGE ²	CHASSIS	RELAY CHASSIS	RELAY ENCLOSED
1.5 and 3.0	533BC	Not Available	Not Available

Notes:

- 1) 1/8 - 1.0 h.p. uses 115VAC input, 0-90VDC output and 100VDC field; 1/4 - 2.0 h.p. uses 230VAC input, 0-180VDC output and 200VDC field
- 2) 1.5 h.p. uses 115VAC input, 0-90VDC output and 100VDC field; 3.0 h.p. uses 230VAC input, 0-180VDC output and 200VDC field

CONTROL FEATURES

INPUT VOLTAGE SELECTION SWITCH - Switch **selectable** between 115 VAC and 230 VAC input.

MIN SPEED - (Minimum speed) Allows adjustment of the motor speed when the speedpot is set at minimum. This permits the user to eliminate the "Deadband" on the main speed control, permitting zero calibration. Clockwise rotation of the "MIN" trimpot increases output VDC.

ACCEL - (Acceleration) Allows adjustment of the motor acceleration from a minimum of 0.3 seconds to a maximum of 12 seconds. The -15A option extends the maximum acceleration time to 30 seconds.

DECEL - (Deceleration) Allows adjustment of the motor deceleration from a minimum of 0.6 seconds to a maximum of 12 seconds. The -15A option extends the maximum deceleration time to 30 seconds.

MAX SPEED - (Maximum speed) Allows adjustment of the motor speed when the speedpot is set at maximum (CW). This permits the user to eliminate the "DEADBAND" of the speedpot, providing full speed at maximum rotation. Rotation of the "MAX" trimpot in the clockwise direction increases maximum output VDC.

I.R. COMP - (Speed Regulation) Allows adjustment of the circuitry that controls the speed regulation of the motor. This feature controls armature speed by changing the armature voltage to compensate for increased or decreased motor loading. Clockwise rotation of the "I.R. COMP" trimpot will increase gain compensation.

CUR. LIM. - (Current Limit) Provides protection from excessive armature current by limiting the maximum armature current the control can provide. This enables adjustment of the maximum torque the motor can deliver. Set Current Limit (CUR. LIM.) at 125% of the rated motor current. Clockwise rotation of the "CUR. LIM." trimpot increases the torque (current) the control will provide.

TACH INPUT SELECTION - Factory set at 3V per 1000 RPM, jumper selectable (JU3) to 7V per 1000 RPM. Refer to "Tach Feedback" section in "Control Modifications" for more information.

TERMINAL STRIP P1 - Barrier type terminal strip provides for connection of AC lines, motor leads, motor field (if necessary), and earth ground.

TERMINAL STRIP P2 - Barrier type terminal strip provides for connection of speed potentiometer and any accessories and/or jumper wires which control the drive.

RELAY - (Power Interrupt Relay's) Available only on the "RC" and the "RE" versions, the relay's permits the switching of AC power with a low current signal. For the "RE" version, the relay's will not allow start up after power failure without manually restarting.

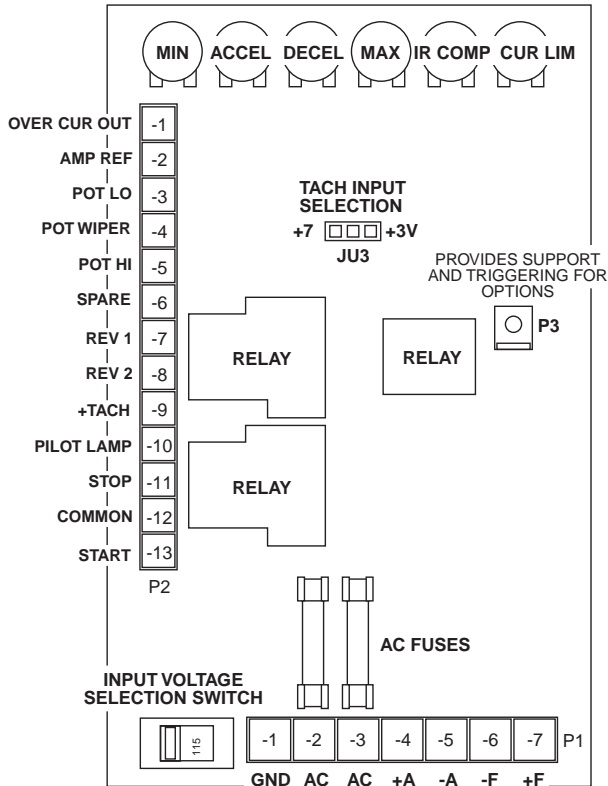

OVERALL CONTROL DIMENSIONS

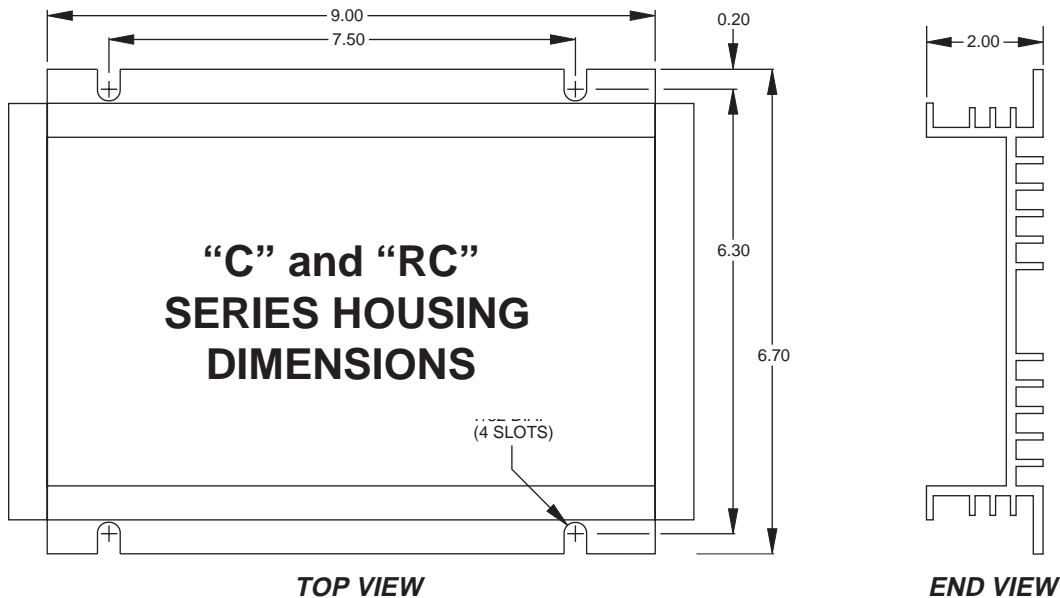

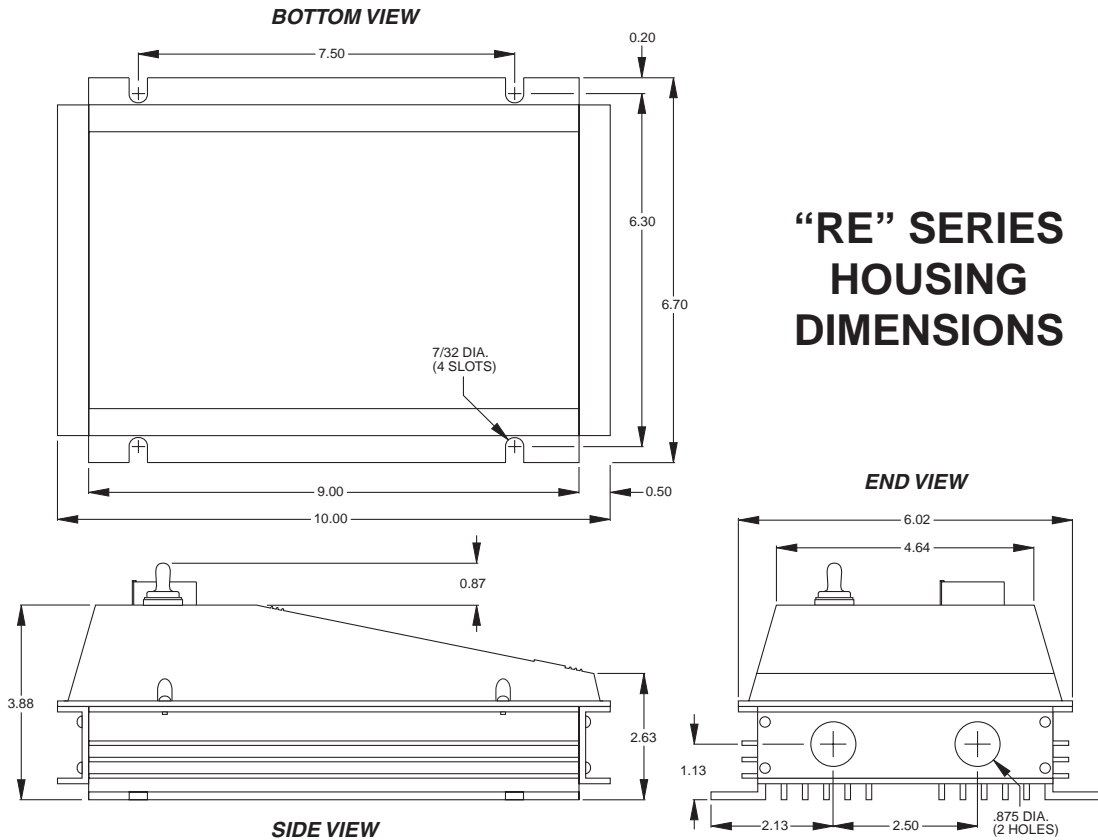

SPEEDPOT MOUNTING DIMENSIONS

(For “C” and “RC” versions)

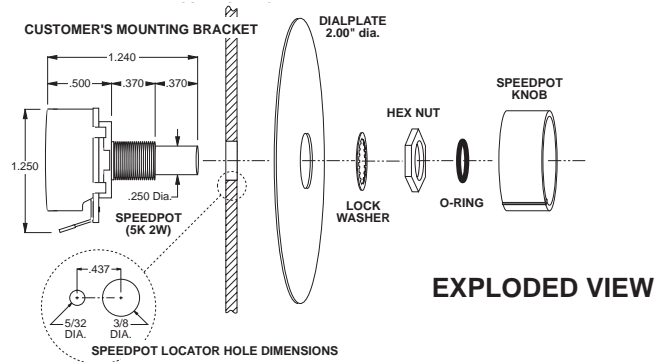

DO NOT MOUNT CONTROL WHERE AMBIENT TEMPERATURE IS OUTSIDE RANGE OF -10° to 45° C. (15° to 115° F.)

MOUNTING INSTRUCTIONS

1. Four 7/32" slots are provided for control mounting.
2. The 530B Series chassis can be used as a template.
3. Use standard hardware to mount.
4. For the “RE” version ONLY: Two 7/8" diameter holes are provided in one endplate to facilitate wiring. This allows for easy connection of 1/2" conduit.

NOTE: For enclosed models using 1 h.p. 90V or 2 h.p. 180V motors, the control MUST be mounted vertically.

CAUTION:

DO NOT ATTEMPT TO PERFORM HI-POT TEST ACROSS AC LINES WITH THE CONTROL IN CIRCUIT. THIS WILL RESULT IN IMMEDIATE OR LONG TERM DAMAGE TO THE CONTROL.

WIRING PROCEDURE

1. Size all wires which carry armature or line current to handle currents AS SPECIFIED BY NATIONAL, STATE, AND/OR LOCAL CODES. All other wires may be # 20AWG or smaller as permitted by local code.
2. Control wire (Pot, Tach, etc.) should be separated from all the Armature, Field (if Shunt Wound), and the AC wires when routed in conduits or in wire trays. The enclosed version has two holes on one endplate for this purpose.

TERMINAL STRIP WIRING - P1

CAUTION: BE SURE CONTROL HOUSING IS PROPERLY GROUNDED.

The 530B Series uses a 7 position barrier type terminal strip to handle the power connections.

- P1-1 (EARTH GROUND)** - Ground the control by connecting the ground wire to this terminal. NOTE: Terminals P1-5 (-ARM) and P2-2 (AMP REF) are electrically the same, which is the common reference point (low voltage common) for the control logic. The EARTH GROUND terminal (P1-1) is electrically different from common. If connected together, either at the amplifier or in any other fashion, fatal or hazardous operation may occur and permanent damage to the control WILL result!
- P1-2 (AC1) 115VAC** - Connect incoming hot AC (black wire) to this terminal. NOTE: This is fused (F1) on the control.
(AC1) 230VAC - Connect either hot side.
- P1-3 (AC2) 115VAC** - Connect the neutral AC (white wire) to this terminal. NOTE: This is fused (F2) on the control.
(AC2) 230VAC - Connect either hot side.
- P1-4 (+ ARMATURE)** - Connects to the plus (+) Armature wire on the motor. 0-90VDC for 115VAC input or 0-180VDC for 230 VAC input. See "SPECIFICATIONS" for output rating.

CAUTION: ARMATURE CONNECTION MUST NOT BE SWITCHED OR BROKEN WHILE CONTROL IS ON OR SERIOUS DAMAGE TO THE CONTROL MAY RESULT.

- P1-5 (- ARMATURE)** - Connects to minus (-) Armature wire (also considered circuit common) on the motor.
- P1-6 (- FIELD)** - Connect minus (-) Field wire of the Shunt Wound motor (not used on PM motors).

FIELD VOLTAGE TABLE		
Model #	VAC Input	VDC Field
530B Series	115	100
	230	200

- P1-7 (+ FIELD)** - DO NOT use for Permanent Magnet motor. This supplies + Field voltage for a Shunt Wound motor. See chart above for dual voltage Field Wound motors. This output is rated at 1 Amp for 530B series controls and 1.5 Amps for the 533B control. For motors with dual voltage field (ie. 50/100V or 100/200V), make sure the highest value is connected.

TERMINAL STRIP WIRING - P2

The 530B Series uses a 13 position barrier type terminal strip for control connections.

CAUTION: NONE OF THE P2 TERMINALS SHOULD BE EARTH GROUNDED!

- P2-1 (OVER CURRENT OUT)** - Can be used to signal that the control is in current limit. It can also signal other devices or alarms. This is a low level logic signal which goes "high" when the current limit amplifier is in current limit. The logic of this control is +12 volts, while the output at this terminal is approximately 1.5 volts through a 1000Ω resistor when in Current Limit.
- P2-2 (AMP REF)** - This is the common point of the logic. It is used as common with OVER CURRENT OUT (P2-1), +TACH (P2-9), REV 1 (P2-7), REV 2 (P2-8), and WIPER (P2-4). NOTE: Never connect this terminal to earth ground!! Serious damage and injury may result!! This terminal is electrically the same point as -ARM (P1-5).
- P2-3 (SPEEDPOT LO)** - Connects to the low side (orange wire) of the 5K Speedpot (normally the CCW end). This input is raised and lowered by the MIN trimpot. Electronic speed input voltage (voltage follower) may be referenced to Speedpot LO if the MIN trimpot adjustments are to be active. Otherwise, inputs may be referenced to AMP REF (P2-2), which will bypass the MIN trimpot. INPUT MUST NOT BE GROUNDED!

**CAUTION FOR VOLTAGE FOLLOWER APPLICATIONS:
THE INPUT CONNECTION TO THE SPEEDPOT MUST NOT BE GROUNDED !!
SERIOUS DAMAGE TO THE CONTROL MAY RESULT FROM A GROUNDED INPUT.**

- P2-4 (SPEEDPOT WIPER)** - Connects to the wiper (red wire) of the Speedpot (center lead). Use this input for the plus (+) side of voltage follower operation or tach follower. The minus (-) side connects to AMP REF (P2-2). INPUT MUST NOT BE GREATER THAN +12V MAXIMUM AND MUST NOT BE GROUNDED!
- P2-5 (SPEEDPOT HI)** - Connects to high side (white wire) of the Speedpot (CW end). This is internal +12 volts. INPUT MUST NOT BE GROUNDED!
- P2-6 (SPARE)** - This terminal is not connected to the control circuit. It can be used as a terminal for field modifications.

(P2 wiring continued)

P2-7 (REV 1) - REV 1 and REV 2 are identical quick stop inputs. One of them must be held low (to AMP REF) before the control will operate. The two are diode separated to form an "OR" gate. Since -ARM (P1-5) is also low in the system, these two inputs can be wired to the motor side of a reversing switch or relay. During the period of switching, neither input will be low, which will instantly return the set speed to zero and reset the acceleration ramp.

P2-8 (REV 2) - Identical to REV 1 (P2-7).

P2-9 (+TACH) - Connect +Tach from a DC tachometer for tachometer feedback. The minus (-) lead from the tachometer goes to AMP REF (P2-2). Output voltage from the tachometer at full speed can range from 6 to 12 volts. The scale is corrected using the JU3 jumper selectable setting of 3V/7V per 1000 RPM and the MAX speed trimpot. A 3 volt per 1000 RPM OR 7 volt per 1000 RPM tachometer should be used.

P2-10 (PILOT LIGHT) - Connecting point for on-off neon indicator lamp. The remaining lead will be connected to P2-11.

P2-11 (STOP) - Install one or more normally closed stop switches (in series) between STOP (P2-11) and COMMON (P2-12). Not active on "C" version.

P2-12 (COMMON) - Mid point of Start-Stop switches. Not active on "C" version.

P2-13 (START) - Install one or more normally open start switches (in parallel) between START (P2-13) and COMMON (P2-12). Not active on "C" version.

SETTING INPUT VAC

For use with 110 through 130 VAC inputs, slide 115/230 VAC input voltage selector switch completely to the left as shown below left. For use with 208 through 240 VAC inputs, slide the same selector switch completely to the right as shown below right.

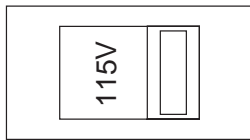

Note:
An incorrect setting of the input VAC selector switch will result in damage to the controller.

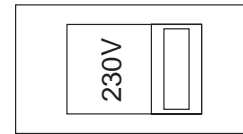

SWITCH LADDER CIRCUIT DIAGRAMS



START-STOP WIRING

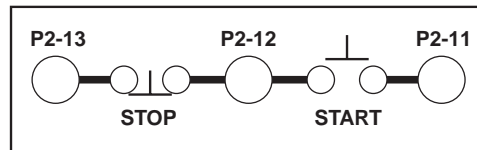

START-STOP WIRING (WITH 3 STATIONS)

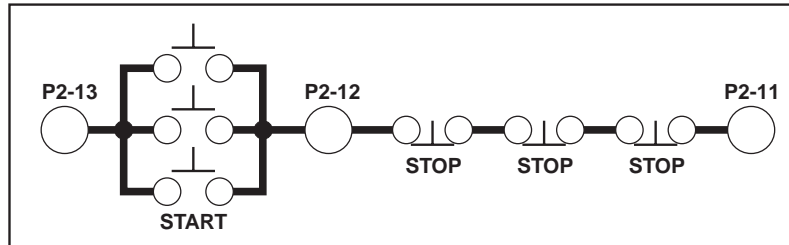

Warning:
This diagram is for "RC" and "RE" versions ONLY! DO NOT use on "C" version.

"RE" CONTROL PANEL IDENTIFICATION

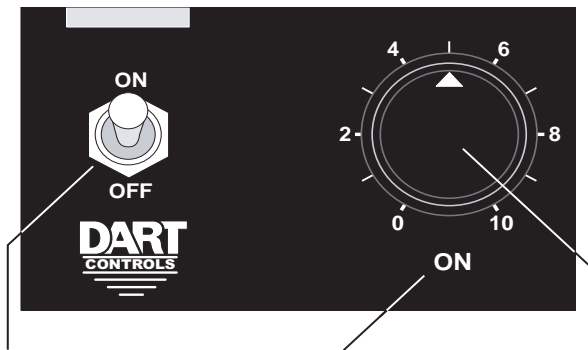

START-STOP SWITCH
MOMENTARY SWITCH TURNS CONTROL ON AND OFF

POWER ON INDICATOR
HIDDEN LED INDICATOR LAMP

SPEED POTENTIOMETER
5000Ω 2W SPEEDPOT
CONTROLS MOTOR SPEED

INITIAL START UP

1. **Check** to see that the **115/230 VAC selection switch is set for the desired input voltage.**
2. Recheck all wiring. Accidental grounds, loose or pinched wires on armature or speed potentiometer wires may damage the control when power is applied.
3. See "ADJUSTMENT PROCEDURE" and observe the WARNINGS pertaining to cover removal for adjustments.
4. Preset trimpots for your horsepower by using the "TRIMPOT CHART". NOTE: Options may change the trimpot setting from this chart. If your control has an option, be sure to carefully read the section in "OPTIONS" that pertains to your option.
5. Turn speed potentiometer to zero (fully CCW).
6. Turn power on and advance speedpot while observing motor.
7. If motor rotation is incorrect, turn power off at external disconnect and reverse the +ARM and -ARM connections.
8. If operation is satisfactory, no re-adjustments are needed.
9. If instability or surging is observed, or if maximum speed is higher than desired, proceed to "ADJUSTMENT PROCEDURE".
10. For other problems, see section "IN CASE OF DIFFICULTY".

WARNING:

WHEN MAKING AN ADJUSTMENT, ALWAYS USE A SCREWDRIVER WITH AN INSULATED SHAFT TO AVOID THE SHORT CIRCUITING OF PC BOARD COMPONENTS. WHENEVER THE CONTROL COVER IS REMOVED, IT MUST BE SUPPORTED TO AVOID ACCIDENTAL CONTACT BETWEEN CONTROL CHASSIS AND LIVE COVER COMPONENTS.

TRIMPOT ADJUSTMENT PROCEDURE

Four adjustments (MIN., MAX., I.R. COMP., and CUR. LIM.) are checked at the factory using a typical motor. Use the "TRIMPOT CHART" to adjust the trimpots to the approximate setting for your horsepower. The other two adjustments (ACCEL and DECEL), are the Acceleration and Deceleration adjustments and should be set for your particular application requirements. The "TRIMPOT CHART" is approximate and is valid when using a speedpot or a 0 to 12VDC input signal to control the speed. Operation of the control beyond $\pm 10\%$ of normal line voltage is not recommended and could result in readjustments. These settings are permanent; periodic readjustment is normally not needed. (NOTE: Use only an ungrounded voltmeter).

MAX. Sets maximum motor speed when speedpot is at 100% CW rotation. Clockwise rotation increases maximum motor speed.

- 1) Turn drive power OFF!
- 2) Connect a DC voltmeter; plus to +ARM and minus to -ARM.
- 3) Set meter voltage range for either 90 VDC or 180 VDC.
- 4) With no load on the motor, adjust the MAX trimpot to the rated armature voltage as seen on the meter.

NOTE: A tachometer or strobe may be used in place of a meter. Follow the above steps, but adjust the MAX trimpot to the rated motor base speed, indicated by tach or strobe.

MIN. Sets minimum motor voltage when Speedpot is set at zero. Clockwise rotation of the MIN. trimpot will increase the minimum motor voltage.

- 1) Set Speedpot to zero (fully CCW).
- 2) With no load on the motor, adjust the MIN trimpot clockwise until the motor starts to rotate.
- 3) Slowly back off the trimpot in the CCW direction until the motor stops.

NOTE: If motor rotation is desired at zero Speedpot setting, adjust the MIN trimpot clockwise until the desired minimum speed is reached.

I.R. COMP. Provides a means of improving speed regulation in the armature feedback mode. If a change in motor speed during a load change is of no concern, rotate this trimpot fully CCW.

- 1) Set speedpot at 50%.
- 2) Observe motor speed during a no load condition.
- 3) Apply a full load to the motor.
- 4) Adjust the I.R. COMP. trimpot clockwise (while the load is applied) until the no load motor speed is obtained.

CUR. LIM. Limits DC motor armature current (torque) to prevent damage to the motor or control. The current limit is set for 125% of the rated motor current. Clockwise rotation of this trimpot increases the armature current (or torque produced).

- 1) Turn drive power OFF!
- 2) Connect a DC Ammeter in series with the +ARM line (between +A on motor and +ARM on the control). Preset the current limit trimpot CCW.
- 3) Turn power on and set speedpot to 50%.
- 4) Increase the motor load until the motor stalls (zero RPM).
- 5) Set CUR. LIM. trimpot by adjusting CW to 125% of the rated motor armature current (see "TRIMPOT CHART").

ACCEL Allows adjustment of acceleration by user.

- 1) Clockwise trimpot rotation increases length of acceleration time needed for the control to reach full speed.

DECEL Allows adjustment of deceleration by user.

- 1) Clockwise trimpot rotation increases length of deceleration time needed for the control to reach zero speed.

TRIMPOT SETTING CHART

MIN	ACCEL	DECEL	MAX	I.R.	CUR LIM	HP	VOLTS	MIN	ACCEL	DECEL	MAX	I.R.	CUR LIM	HP	VOLTS
						1/8	115							1/4	230
						1/6	115							1/3	230
						1/4	115							1/2	230
						1/3	115							3/4	230
						1/2	115							1.0	230
						3/4	115							1.5	230
						1.0	115							2.0	230
						1.5	115							3.0	230

NOTES: These settings apply when using a 5000Ω speedpot. This chart cannot be used with certain Options (refer to Option section)

1.5 and 3.0 HORSEPOWER - MODEL 533BC

For 1.5 and 3.0 horsepower applications, the model 533BC control has the following restrictions:

- Available in chassis (C) mount only.
- The 1.5 horsepower model is available in 115 VAC input at 0-90 VDC out, while the 3.0 horsepower model is available in 230 VAC input at 0-180 VDC out.
- Relay, start-stop, reversing, dynamic braking & jogging are not available from factory (they are customer supplied and wired).
- The isolation boards (-5 and -7 options) are available. The current limit shutdown (-6 option) is factory installed, however the customer must supply relay contactor.

BASIC HOOK-UP DIAGRAMS WITHOUT OPTIONS

(If options are included on your control, see the option section of this manual).

Model 530BC and 533BC ("C Version")

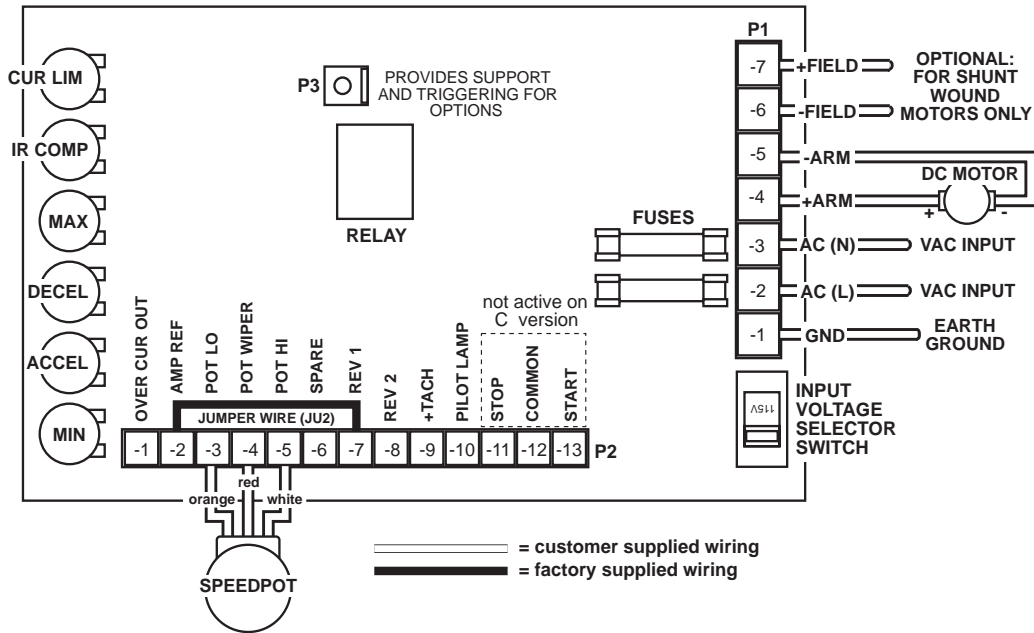

Model 530BRC ("RC Version")

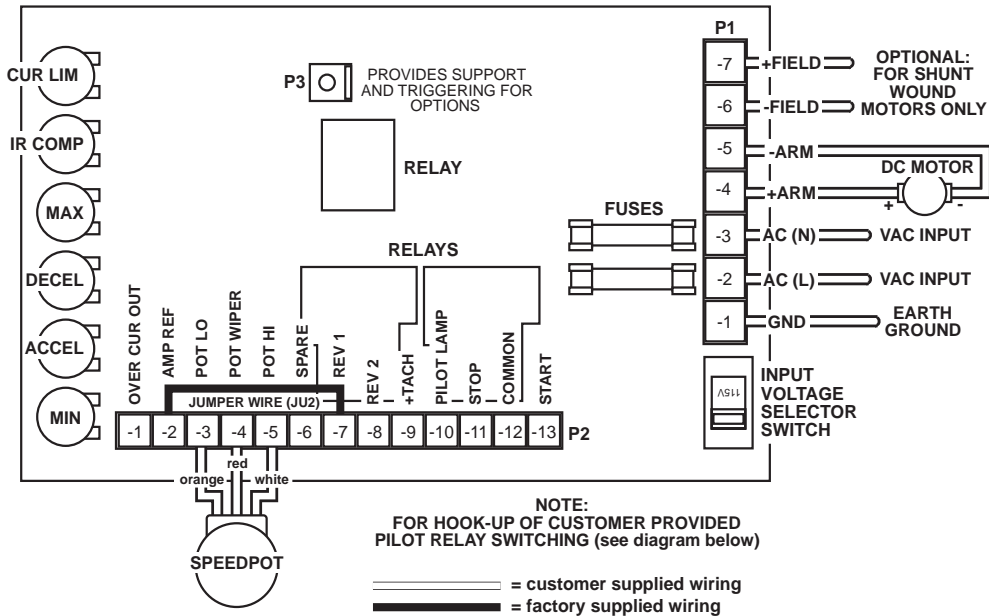

PILOT RELAY SWITCHING

(Customer supplied wiring for the "530BRC" version)

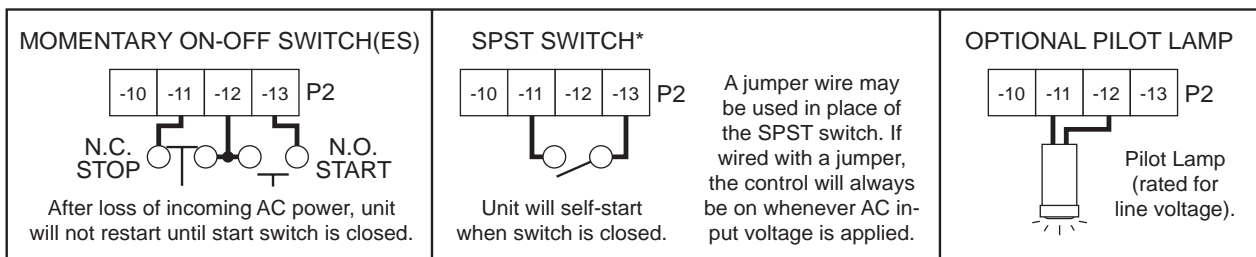

Model 530BRE ("RE Version")

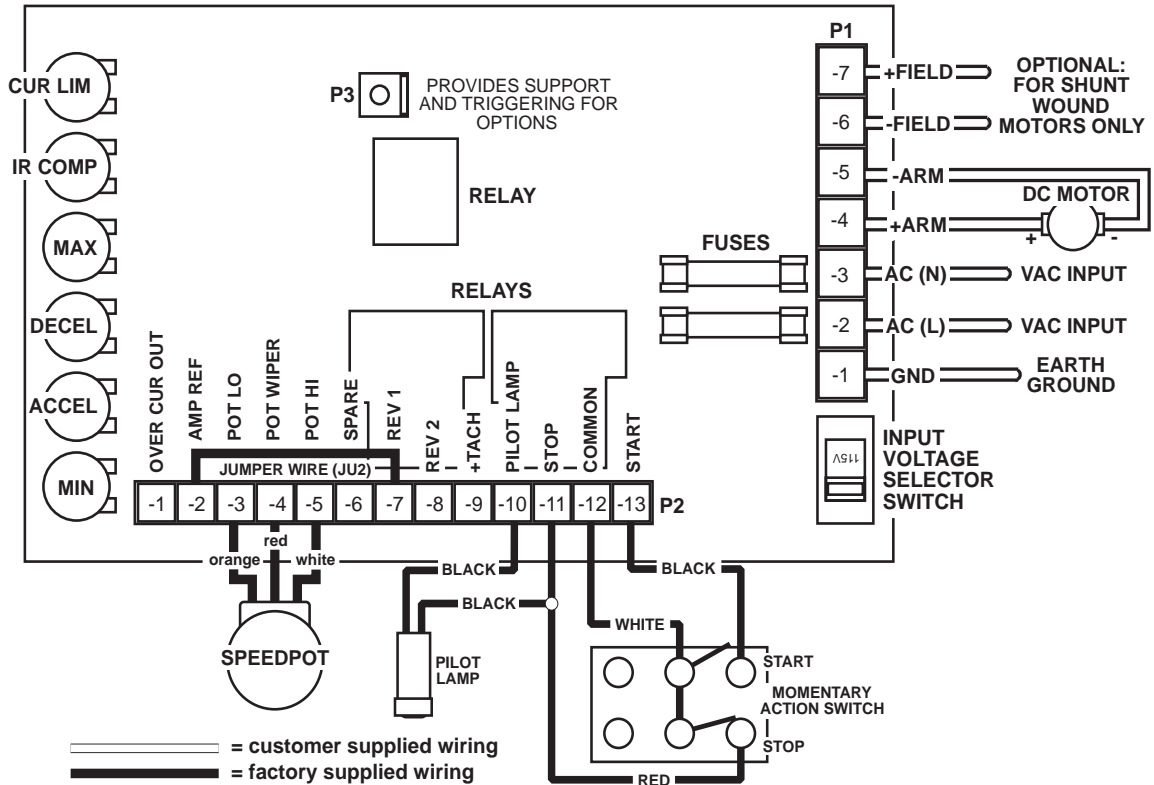

JU2 JUMPER WIRE SELECTION CHART

NOTE: Jumper wires may be required on terminal strip P2 for the control to operate (refer to jumper chart below).

As explained in the "COMMONLY ASKED QUESTIONS" section, REV 1 (P2-7) and REV 2 (P2-8) are both stop inputs. One of these inputs must be held low to AMP REF (P2-2) for the control to operate. Jumpering is necessary between AMP REF and REV 1 or REV 2 to satisfy the "OR" gate. An option board may be installed on the control satisfying the "OR" gate. This jumper (between P2-2 and P2-7) is called JU2. For inhibiting with soft start and fast stop, the JU2 jumper may be replaced by a SPST switch.

YES = JUMPER REQUIRED

NO = JUMPER NOT USED

OPTION	DESCRIPTION	PAGE #	JUMPER	"C"	"RC"	"RE"
NONE	STOCK CONTROL	9-10	JU2	YES	YES	YES
-4	JOG	11	JU2	YES	YES	YES
-5/-7	CURRENT FOLLOWER	12-13	JU2	YES	YES	YES
-6	CURRENT LIMIT INTERRUPT	12	JU2	YES	YES	YES
-36M/-38M	FWD / REV with ZERO SPEED and D.B.R.	14-15	JU2	NO	NO	NO

NOTE: Installing JU2 jumper when not required may cause permanent damage to control.

CONTROL MODIFICATIONS

TWO SPEED OPERATION

Two pot operation is done using two 10KΩ speed potentiometers in parallel (both HI's to P2-5, both LO's to P2-3). The WIPER is switched using a SPDT switch.

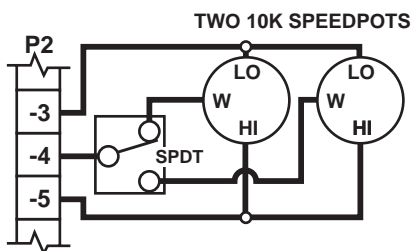

DYNAMIC BRAKING

A DPDT switch is used to inhibit the control and to connect the DBR. Typical values for the DBR (dynamic brake resistor) are 5 for 115V, 10 for 230V (both 35Ω to 50Ω). Note that motor horsepower, inertia, and cycle time effect sizing of the DBR.

NOTE: On -15A Option, Decel must be fully CCW to use with DBR.

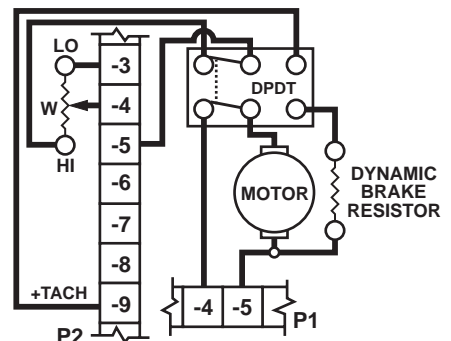

TACHOMETER FEEDBACK

Improves speed regulation to $-1/2\%$ of base speed.

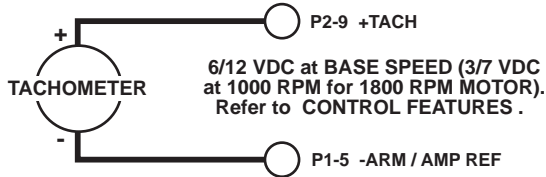

NOTE: NEED 1% OR LESS - TACH OUTPUT RIPPLE

TACHOMETER FOLLOWER

Allows control output to follow tachometer voltage.

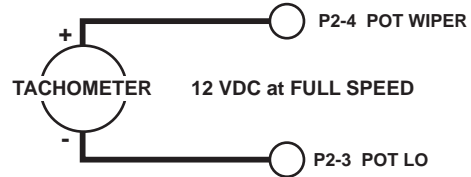

INHIBIT (USED INDEPENDENTLY)

The customer supplied SPST switch is connected in series between the speedpot HI (P2-5) and the +TACH terminal (P2-9). To inhibit, speedpot HI is closed to the +TACH terminal. To restart, the switch is returned to open. NOTE: The control will stop and start fast.

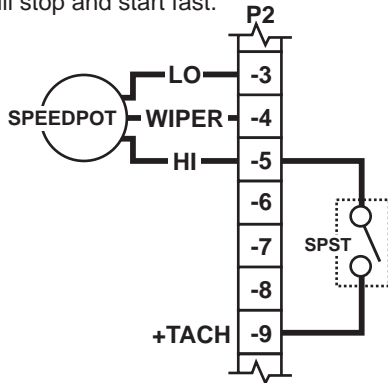

NOTE: Permits starting and stopping of motor without breaking AC lines. In the event of SCR failure or false triggering, the Inhibit circuit will not stop motor.

INHIBIT (USED WITH SPEEDPOT)

The customer supplied SPST switch is connected in series between the speedpot HI terminal (P2-5) and speedpot HI. To inhibit, the SPST switch contacts are opened. To restart, the switch is returned to the closed position. NOTE: The control will soft stop and soft start through the acceleration setting.

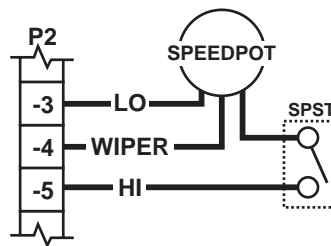

Always use a shielded wire when connecting to the inhibit terminal. The shield should be connected to the -Armature or Common of the control.

OPTIONS

NOTE: All options are specified by a suffix to the model number. This suffix starts with a dash (-). The more popular options are described on the following pages. When a combination of two or more of these options are used, the wiring procedure is beyond the scope of this manual. Please contact your Distributor or Representative.

-4 Option Jog

See below for installation and availability

This option is factory installed on the "RE" version only. "S2" is located on the cover and disables the latch circuit of the power relay's, allowing the power switch to jog the drive. The "C" and "RC" versions use customer supplied switch and wiring, in addition the "C" version uses a customer supplied relay.

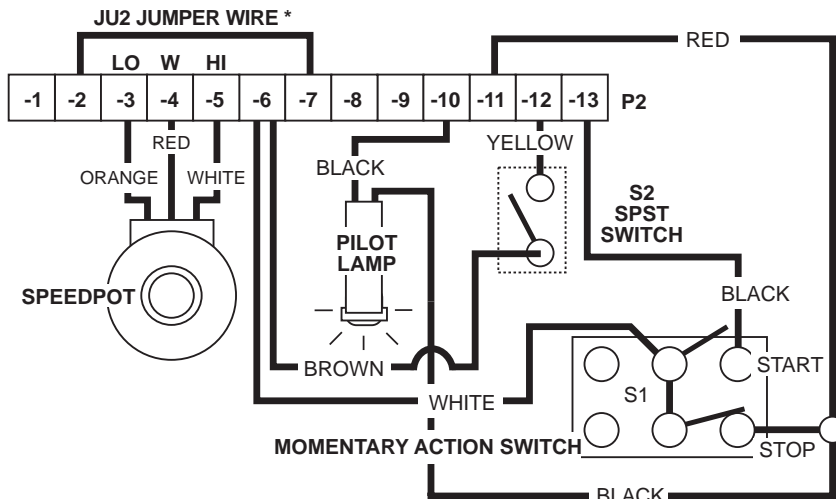

NOTES:

For "RE" version, S1, S2 and pilot lamp are FACTORY PROVIDED.

For "C" and "RC" versions, S1, S2, and pilot lamp are CUSTOMER PROVIDED.

* This jumper wire is not used with some other options. Consult factory if more than one option is being wired. Using JU2 jumper when not required may cause permanent damage to the control.

-5 Option
Isolated 4-20 ma.Signal Follower

*Available on "C" and "RC" models only**
Factory or Field installed

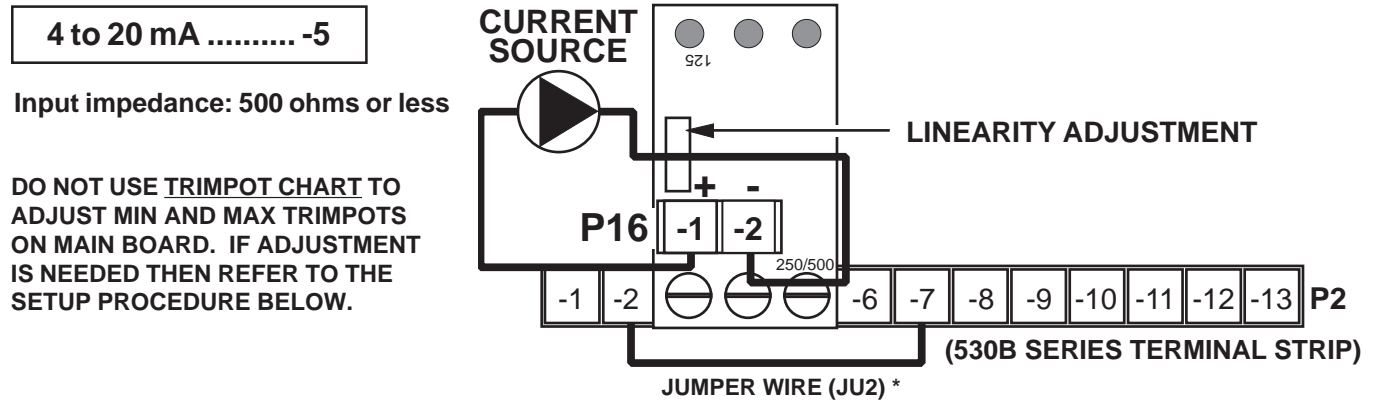

This option replaces the speedpot with a 4-20 ma. signal to control speed. The current signal input can be either grounded or ungrounded. The board sets on spacers screwed to terminals P1-3, P1-4, and P1-5 on the main board using long screws. The current source connects to the + and - two position terminal strip (P16-1 and -2) on the -5 option board.

The Linearity trimpot on the -5 option board is set at the factory for proper linearity, however this trimpot may need to be re-set after tuning the controls Max and Min trimpot settings for your specific application. If needed then refer to the setup procedure below.

Setting the Min, Max and Linearity Trimpots.

1. Preset the multi-turn Linearity trimpot on the -5 option board full CW, set the Min trimpot full CCW and set the Max trimpot at about 50% rotation.
2. Input a 4 ma. current signal to the control and turn the Min trimpot CW to your desired minimum output voltage or to deadband (the point just before you begin to get an output).
3. Input a 20 ma. current signal to the control and set the Max trimpot to the desired maximum speed setting.
4. With 20 ma. still going to the control, turn the Linearity trimpot CCW until your output speed starts to decrease. Then slowly turn it back CW until you just reach your maximum speed setting.

For enclosed models use -7 option.

*** Note:** This jumper wire is not used with some options. Consult factory if more than one option is being wired. Using the JU2 jumper wire when not required may cause permanent damage to the control.

-7 Option
Isolated 4-20 ma. Signal Follower
with Auto / Manual Switch

Factory or Field installed Chassis unit
Factory only on Enclosed models
Available on all models

Input impedance equals 500Ω or less

DO NOT USE TRIMPOT CHART TO ADJUST MIN AND MAX TRIMPOTS ON MAIN BOARD. IF ADJUSTMENT IS NEEDED THEN REFER TO THE SETUP PROCEDURE BELOW.

This option allows the control to be run in either the Manual mode via a speed pot or the Auto mode via the 4-20 ma. signal. The current signal input can be either grounded or ungrounded. The board sets on spacers screwed to terminals P1-3, P1-4, and P1-5 on the main board using long screws. The current source connects to the + and - two position terminal strip (P16-1 and -2) on the -7 option board.

This option includes a Balance trimpot which is used to scale the maximum speed in the manual mode. It is factory set so the maximum speed in manual equals the maximum speed in automatic.

The Linearity trimpot on the -7 option board is set at the factory for proper linearity, however this trimpot may need to be re-set after tuning the Max and Min trimpot settings on the control or if the Balance trimpot on the -7 must be reset for your specific application. If needed then refer to the setup procedure below.

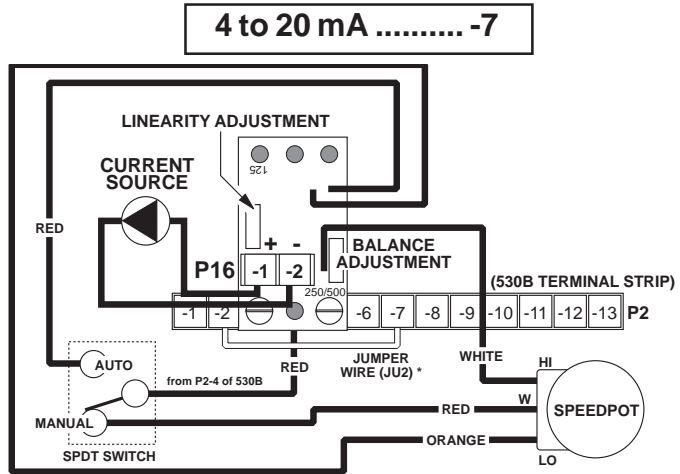

Setting the Min, Max, Balance and Linearity Trimpots.

1. Preset the multi-turn Linearity trimpot and the Balance trimpot on the -7 option board full CW, set the Min trimpot full CCW and set the Max trimpot at about 50% rotation.
2. Input a 4 ma. current signal to the control and turn the Min trimpot CW to your desired minimum output voltage or to deadband (the point just before you begin to get an output).
3. Input a 20 ma. current signal to the control and set the Max trimpot to the desired maximum speed setting.
4. Switch the control to the Manual mode setting and adjust the Balance trimpot CCW as needed to attain your required manual mode maximum output speed. (Adjustable from 50 to 100% of maximum Auto mode setting)
5. Switch the control back to Auto mode. With 20 ma. still going to the control, turn the Linearity trimpot CCW until your output speed starts to decrease. Then slowly turn it back CW until you just reach your maximum speed setting.

*** Note:** This jumper wire is not used with some options. Consult factory if more than one option is being wired. Using the JU2 jumper wire when not required may cause permanent damage to the control.

-11 Option
Ten Turn Speedpot

Field installed - ordered as separate item
Available on "C" and "RC" models only

Provides for a finer control of speed. Installation is the same as the standard speedpot.

-15A Option
Extended Accel / Decel

Factory installed
Available on all models

Extends acceleration / deceleration to 30 seconds (linear ramp).

-36M / -38M Option

Forward / Reverse with Zero Speed
Detect and Dynamic Brake

Factory or Field installed - see below
Available on all models except 3 H.P.

Option	AC Input	Installed	DBR Value	DBR location / placement
-36M	115VAC	factory or field	5Ω 30W	option board mounted
-36MA	115VAC	factory only	5Ω 50W	extrusion mounted
-38M	230VAC	factory or field	10Ω 30W	option board mounted
-38MA	230VAC	factory only	10Ω 50W	extrusion mounted

Warning: The addition of this option no longer allows for dual voltage operation of the 530B series board. The 115/230 VAC input selector switch (530B series board) must be set for the proper VAC input rating of the -36M/-38M option being used.

-36M / -38M HOOK-UP USING SPDT SWITCH OR CONTACT

NOTE:
INPUTS TO TERMINAL STRIP P5 CANNOT BE REFERENCED TO EARTH GROUND!

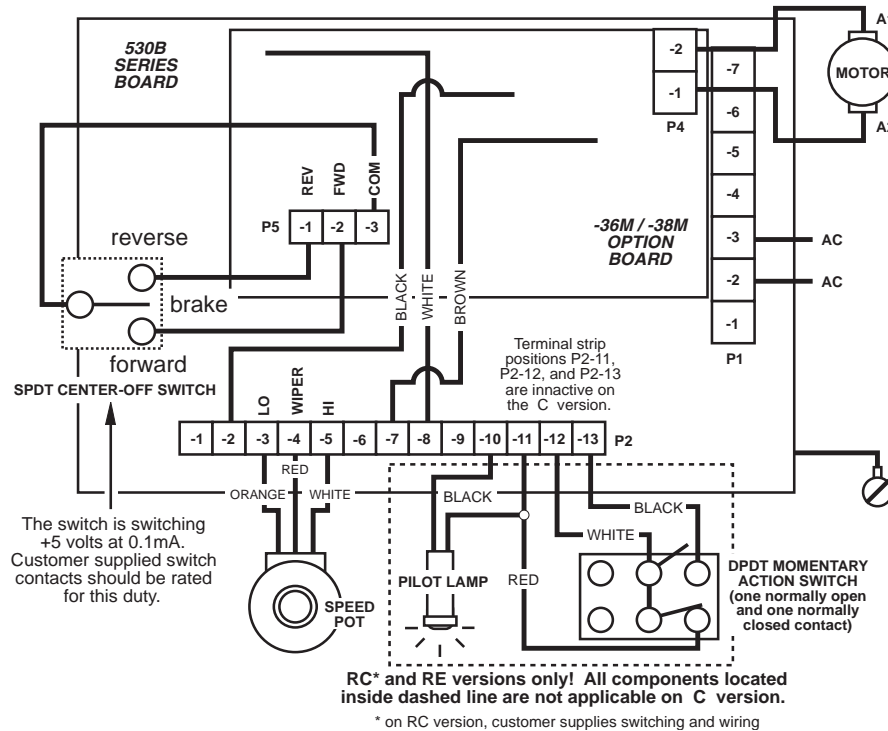

The -36M / -38M option automatically "brakes" to zero speed before reversing. The SPDT center-off switch is used to select direction. When the direction is reversed, relays K1, K2, and K3 connect the dynamic brake resistor to the armature. The motor "brakes" and at zero speed the relays reverse the armature leads, causing the motor to rotate in the opposite direction. When the switch is in the center (STOP) position, the motor armature is connected to the dynamic brake resistor.

Notes: The start-stop switch is customer provided on the "RC" version (see Hook-up Diagrams for switch wiring). The "RE" version requires a special cover that must be ordered for field installed -36M or -38M options. The Dynamic Brake Resistor is mounted accordingly per model (see above chart for placement).

VERY IMPORTANT:
DO NOT USE JU2 JUMPER WIRE with this option. WHEN RETROFITTING, JU2 JUMPER MUST BE REMOVED!!

To identify JU2 jumper location, see "Basic Hook-up Diagrams Without Options".

-36M / -38M HOOK-UP FOR NPN OPEN COLLECTOR DIRECTIONAL CONTROL

NOTE:
INPUTS TO TERMINAL STRIP P5 CANNOT BE REFERENCED TO EARTH GROUND!

Warning:
The addition of this option no longer allows for dual voltage operation of the 530B series board. The 115/230 VAC input selector switch (530B series board) must be set for the proper VAC input rating of the -36M/-38M option being used.

TRANSISTOR "A" ON = FWD.
TRANSISTOR "B" ON = REV.
BOTH "A & B" OFF = DYNAMIC BRAKE
BOTH "A & B" ON = DISALLOWED STATE
(CUSTOMER SUPPLIED LOGIC = A & B)

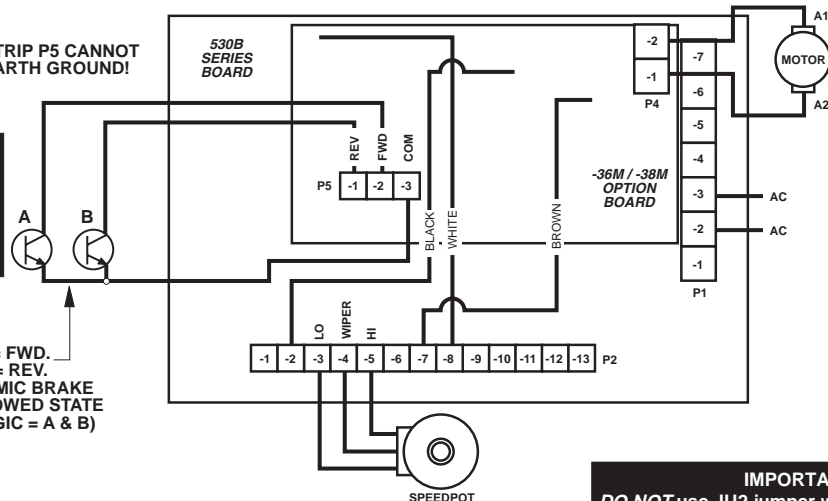

To identify JU2 jumper location, see "Basic Hook-up Diagrams Without Options".

IMPORTANT:
DO NOT use JU2 jumper wire with this option. When retrofitting, JU2 must be removed.

-36M / -38M HOOK-UP FOR UNIDIRECTIONAL RUN / DYNAMIC BRAKE

NOTE:
INPUTS TO TERMINAL STRIP P5 CANNOT BE REFERENCED TO EARTH GROUND!

Warning:
The addition of this option no longer allows for dual voltage operation of the 530B series board. The 115/230 VAC input selector switch (530B series board) must be set for the proper VAC input rating of the -36M/-38M option being used.

IMPORTANT:
DO NOT use JU2 jumper wire with this option. When retrofitting, JU2 must be removed.

To identify JU2 jumper location, see "Basic Hook-up Diagrams Without Options".

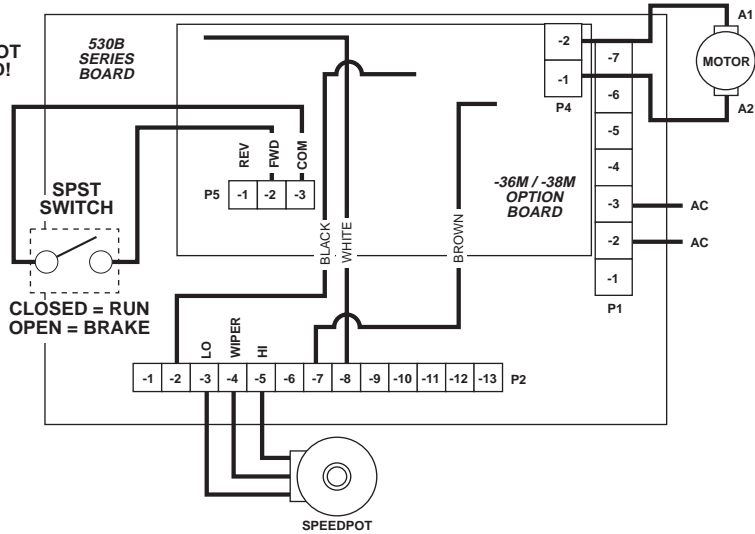

IN CASE OF DIFFICULTY

PROBLEM	POSSIBLE CAUSE(S)	CORRECTIVE ACTION(S)
Motor doesn't operate	Blown fuse Incorrect or no power source Speedpot set at zero Worn motor brushes Improper or missing jumpers	Replace fuse Install proper service Adjust speedpot CW to start Replace motor brushes See "JU2 Jumper Wire Selection Chart"
Armature output voltage cannot be adjusted, output is a constant DC level	No motor or load connected Speedpot low connection open	Check that the motor or load is connected to Armature terminals Check that speedpot low wire is connected
Motor stalls or runs very slowly with speed control turned fully CW	Low voltage Overload condition Worn motor brushes Max. speed set incorrectly	Should be above 104V or 208V Reduce load or re-adjust Current Limit Replace motor brushes See "Adjustment Procedure"
Motor hunts	Too much IR Comp Motor is in Current Limit Motor speed is above rated speed	See "Adjustment Procedure" See "Adjustment Procedure" Reduce Max trimpot setting
Repeated fuse blowing	Overload condition Worn motor brushes Defective motor Failed electrical components	Reduce load Relace motor brushes Replace motor Return for repair
Motor runs but will not stop	Incorrect wiring Defective wiring Failed component	Check "Terminal Strip Wiring" sections Check wiring Return for repair

After using this section, if control will still not operate, consult your Dart Distributor or Representative or return unit for repair.

FUSING

The motor and control are protected against overloads by the current limit circuit. Additional protection is provided through 2 fuses, which are mounted on the main board. Use exact fuse replacements if the fuse requires changing. Before changing fuses, be sure the power to the control is disconnected at the power source. Note: Both sides of VAC input are fused.

HP: 1/8 - 2.0 H.P.	FUSE SIZE: 20 Amp	FUSE TYPE: Bussman ABC-20 or Little Fuse 314020
HP: 3.0 H.P.	FUSE SIZE: 20 Amp	FUSE TYPE: Bussman ABC-20 or Little Fuse 314020

SPECIFICATIONS

AC INPUT VOLTAGE ±10% of rated line voltage
 ALTITUDE Up to 7,500 feet above sea level
 CONTROL OVERLOAD CAPACITY 200% for 1 minute
 DIMENSIONS & WEIGHTS:

	WIDTH	LENGTH	DEPTH	WEIGHT	TYPE
ENGLISH	6.70"	9.00"	2.25"	40 oz.	C
	6.70"	9.00"	2.25"	41 oz.	RC
	6.70"	10.00"	4.75"	56 oz.	RE
METRIC	171 mm	229 mm	51 mm	1134 gm.	C
	171 mm	229 mm	57 mm	1162 gm.	RC
	171 mm	254 mm	121 mm	1422 gm.	RE

DRIVE SERVICE FACTOR 1.0
 EFFICIENCY 85% typical
 ELECTRICAL SPECIFICATIONS - TYPICAL CURRENT & HORSEPOWER RANGES:

	115VAC INPUT / 0-90VDC OUTPUT		230VAC INPUT / 0-180VDC OUTPUT	
H.P.	MAX AC AMPS	MAX ARM AMPS	MAX AC AMPS	MAX ARM AMPS
1/8	1.80	1.40	-----	-----
1/6	2.60	2.10	-----	-----
1/4	3.50	2.70	1.80	1.40
1/3	4.40	3.40	2.20	1.70
1/2	6.50	5.00	3.30	2.50
3/4	9.30	7.20	4.80	3.70
1.0	13.20	10.20	6.50	5.00
1.5	21.50	14.70	9.70	7.50
2.0	-----	-----	12.90	9.90
3.0	-----	-----	22.00	15.00

FUSE PROTECTION 2 AC line fuses (see "Fusing")
 HUMIDITY 99% non-condensing
 INPUT FREQUENCY 50 or 60 Hertz
 MAXIMUM ARMATURE CURRENT - CONTINUOUS 10 ADC (2 H.P.); 15 ADC (3 H.P.)
 PILOT LAMP ("RE" VERSION) Neon
 POWER DEVICES Packaged full wave bridge
 SHUNT FIELD VOLTAGE 100VDC for 115VAC in; 200VDC for 230VAC in; (1.0 A max. - 530B; 1.5 A max. - 533B)
 SPEED CONTROL Via 5KΩ Potentiometer OR 0 to +10 VDC isolated signal
 SPEED RANGE 50:1
 SPEED REGULATION ±1% of base speed
 TACHOMETER FEEDBACK jumper selectable 3V or 7V per 1000 RPM
 TEMPERATURE RANGE -10° to 45° C. ambient (15° to 115° F.)
 TRANSIENT VOLTAGE PROTECTION G-Mov
 TRIMPOTS:

ACCELERATION RANGE 0.3 to 12 seconds - adjustable
 CURRENT LIMIT RANGE 1 to 20 Amps (1/8 to 2 H.P.)
 2 to 30 Amps (1.5 and 3 H.P.)
 DECELERATION RANGE 0.6 to 12 seconds - adjustable
 I.R. COMPENSATION RANGE 1/8 through 2.0 h.p. (530B controls)
 1.5 and 3.0 h.p. (533B control)
 MAXIMUM SPEED RANGE 60% to 120% of base speed
 MINIMUM SPEED RANGE 0 to 30% of maximum speed
 TYPE RAMP OF ACCEL / DECEL Linear

530B SERIES PARTS PLACEMENT & LIST

RESISTORS

R1	220K
R2	5K TRIM (MIN)
R3	47K
R4	300K
R5	10K
R6	4.7K
R7	250K TRIM (ACCEL)
R8	1K
R9	27K
R10	4.7K
R11	250K TRIM (DECEL)
R12	1K
R13	47K
R14	4.7K
R15	47Ω 1/2W
R16	91K 1/2W
R17	180K 1/2W
R18	470Ω
R19	47K
R20	6.8K
R21	300K
R22	1K
R23	47K
R24	470K
R25	10K
R26	680K
R27	22K
R28	2.2K
R29	1K
R30	220K
R31	390Ω
R32	390Ω
R33	39K
R34	1K TRIM (CUR)
R35	2.2K
R36	470Ω
R37	50K TRIM (MAX)
R38	100Ω TRIM (I.R.)
R39	.SEE BELOW
R40	100K
R41	SEE BELOW
R42	33K
R43	100K

ACTIVE DEVICES

Q1	2N4124
Q2	LM78L12 REG.
U1	LM358 IC
U2	LM324 IC
U3	3052 MOC
U4	L512F BRIDGE

CAPACITORS

C1	.01μF 63V
C2	1μF 50V N.P.
C3	.01μF 400V
C4	.01μF 400V
C5	.068μF 250VAC
C6	.01μF 400V
C7	.01μF 63V
C8	NOT USED
C9	.22μF 250V
C10	150μF 16V
C11	47μF 16V
C12	470μF 50V
C13	1μF 50V N.P.
C14	.1μF 63V

DIODES

D1	S6A4
D2	S6A4
D3	1N4005
D4	1N4005
D5	1N914B
D6	1N5233B
D7	1N914B
D8	1N5242B
D9	1N4005
D10	1N5233B
D11	1N4005
D12	1N4005
D13	1N914B
D14	1N4005
D15	1N4005
D16	1N4005

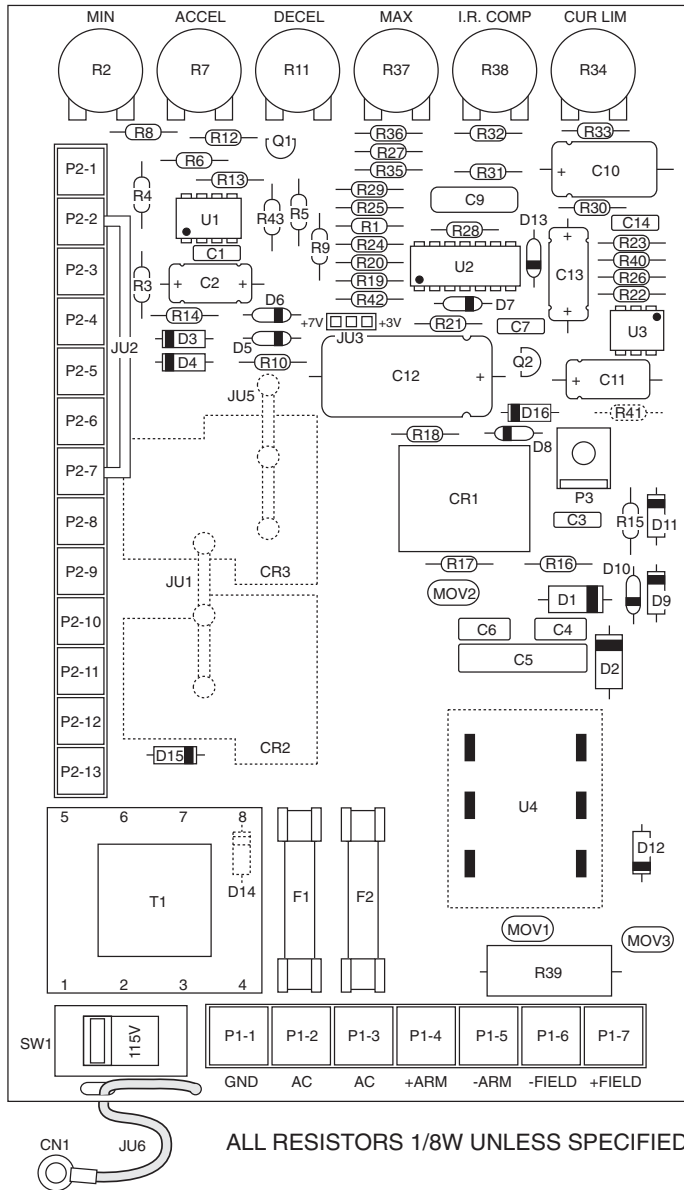

MISCELLANEOUS

CN1	CT60R16USB CONNECTOR	JU6	WC16GN3.5 WIRE
CR1	T73 RELAY	MOV1	275V G-MOV
CR2	SEE BELOW	MOV2	275V G-MOV
CR3	SEE BELOW	MOV3	275V G-MOV
F1	20A FUSE	PCB	A-4-2563C PRINTED CIRCUIT
F2	20A FUSE	P1	7 POS. TERMINAL STRIP
JU1	SEE BELOW	P2	13 POS. TERMINAL STRIP
JU2	WC16WH2.5SL JUMPER WIRE (SEE MANUAL "JUMPER WIRES")	P3	1/4" MALE SPADE PIN
JU3	3 POS. MALE CONN. W/JUMPER	SW1	115/230VAC SWITCH (DPDT)
JU5	SEE BELOW	T1	DST428 TRANSFORMER

-6 OPTION CHANGES

C9	.033μF 400V
D13	NOT USED
R30	10K

-15A OPTION CHANGES

R13	180K
-----	------

530BC CHANGES:

CR2	NOT USED
CR3	NOT USED
JU1	RLB2503S RAIL
JU5	RLB2503S RAIL
R39	.015Ω 5W
R41	1K 1/2W

530BRC CHANGES:

CR2	T9A RELAY
CR3	T9A RELAY
JU1	NOT USED
JU5	NOT USED
R39	.015Ω 5W
R41	NOT USED

530BRE CHANGES:

CR2	T9A RELAY
CR3	T9A RELAY
JU1	NOT USED
JU5	NOT USED
R39	.015Ω 5W
R41	NOT USED

533BC CHANGES:

CR2	NOT USED
CR3	NOT USED
JU1	RLB2503S RAIL
JU5	RLB2503S RAIL
R39	.005Ω 5W
R41	1K 1/2W

530B SERIES SCHEMATIC

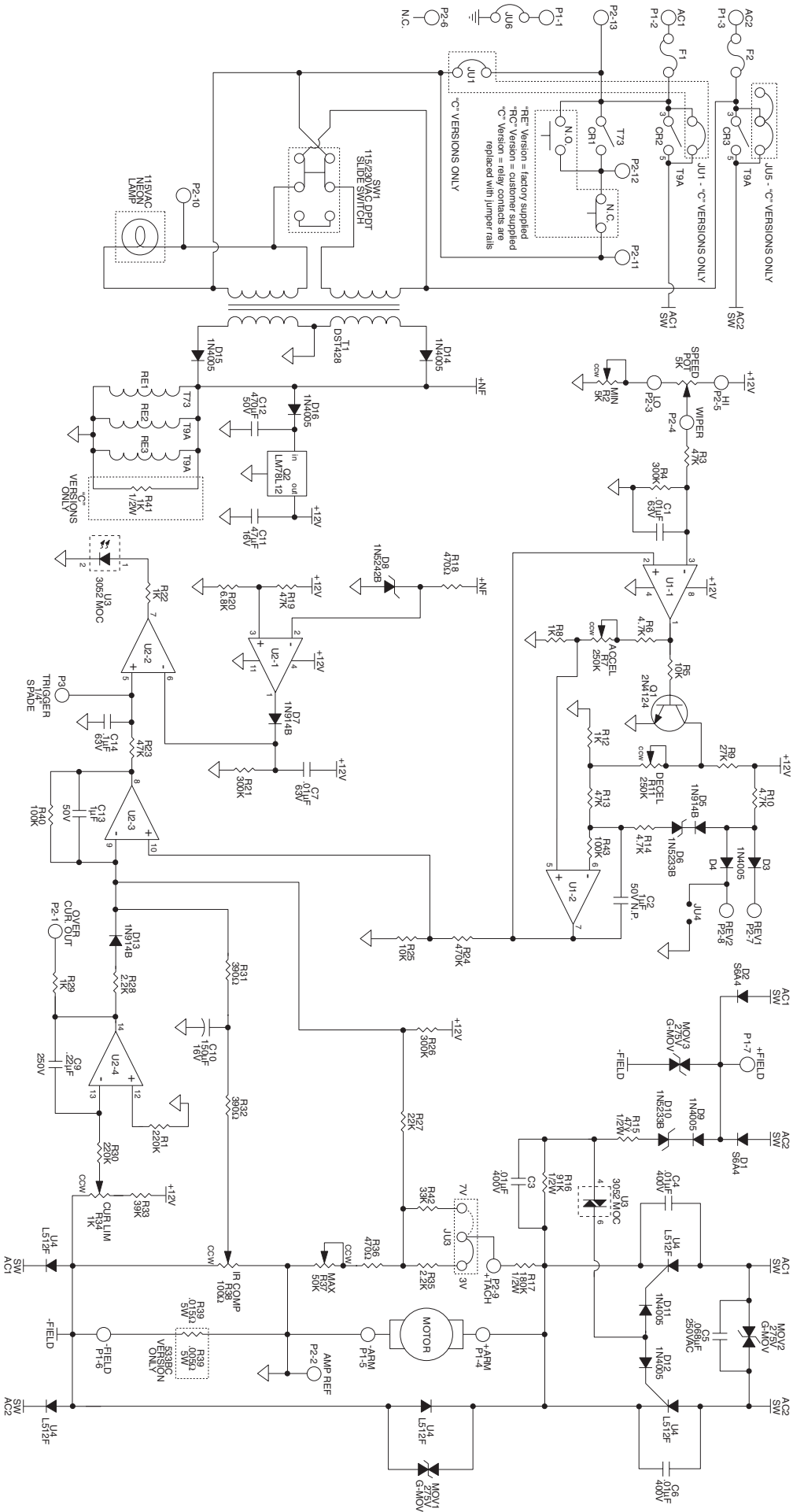

REPAIR PROCEDURE

In the event that a Product manufactured by Dart Controls Incorporated (DCI) is in need of repair service, it should be shipped, freight paid, to: Dart Controls, Inc., 5000 W. 106th Street, Zionsville, IN. 46077, ATTN: Repair Department.

Please include with each order a P.O. number to cover any repair charges (a P.O. is needed even on warranty returns to cover misuse or other failures that have voided warranty), and include a note with a brief description of the problem experienced. **NO WORK WILL BE DONE ON ANY ORDER WITHOUT A P.O. NUMBER.**

Completed repairs are returned with a Repair Report that states the problem with the control and the possible cause. Repair orders are returned via UPS Ground unless other arrangements are made. If you have further questions regarding repair procedures, contact your Dart Distributor or Representative.

YOUR MOTION SYSTEMS SOLUTION PROVIDER



125D SERIES
AC INPUT - VARIABLE DC OUTPUT
1/50 HP through 1.0 HP



250G SERIES
AC INPUT - VARIABLE DC OUTPUT
1/50 HP through 2.0 HP



65 SERIES
DC INPUT - VARIABLE DC OUTPUT
CURRENT RATINGS OF 20, 40, AND
60 AMPS



700/COMMUTROL SERIES
DC BRUSHLESS
5 & 20 Amp for
12,24,& 36VDC Inputs



MDP SERIES
PROGRAMMABLE
CLOSED LOOP DC
SPEED CONTROL



DM SERIES
FIELD PROGRAMMABLE
DIGITAL TACHOMETER

Dart Controls, Inc. is a designer, manufacturer, and marketer of analog and digital electronic variable speed drives, controls, and accessories for AC, DC, and DC brushless motor applications.

Shown above is just a sampling of the expanded line of Dart controls that feature the latest in electronic technology and engineering. Products are manufactured in the U.S.A. at our Zionsville (Indianapolis,

Indiana) production and headquarters facility - with over 2,000,000 variable speed units in the field.

In addition to the standard off-the-shelf products, you can select from a wide variety of options to customize controls for your specific application. For further information and application assistance, contact your local Dart sales representative, stocking distributor, or Dart Controls, Inc.

Dart Controls, Inc.

Manufacturer of high quality DC and AC motor speed controls and accessories since 1963.

P.O. Box 10
5000 W. 106th Street
Zionsville, Indiana 46077
Phone: (317) 733-2133
Fax: (317) 873-1105



Vilter Manufacturing Corporation
5555 South Packard Ave.
PO Box 8904
Cudahy, WI 53110-8904
Telephone: 414-744-0111
Fax: 414-744-1769
e-mail: service@vilter.com