



F-series scroll condensing units - 60Hz

For medium and low temperature refrigeration applications



Key features of scroll units

- Optimal layout of components, tubing and electrical connections for easy serviceability
- Energy efficient silent fans
- Condenser coils designed for high ambient conditions
 - Large condenser face area and higher CFM for elevated ambient conditions
- Liquid receiver, HP/LP switch and crankcase heater as standard feature
- Pre-wired electrical junction box
- Copeland Scroll™ compressor
 - Proven reliability
 - Lower sound levels and pulsations
 - Dual compliance for superior efficiency and better liquid handling

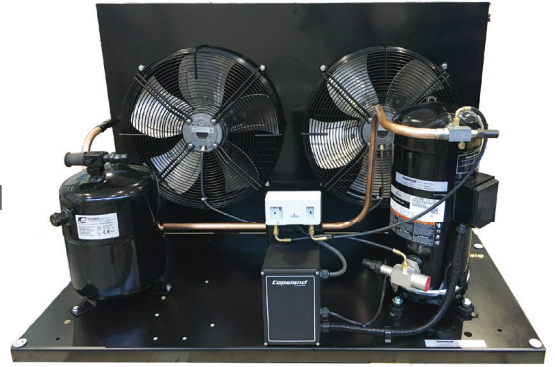

Nomenclature

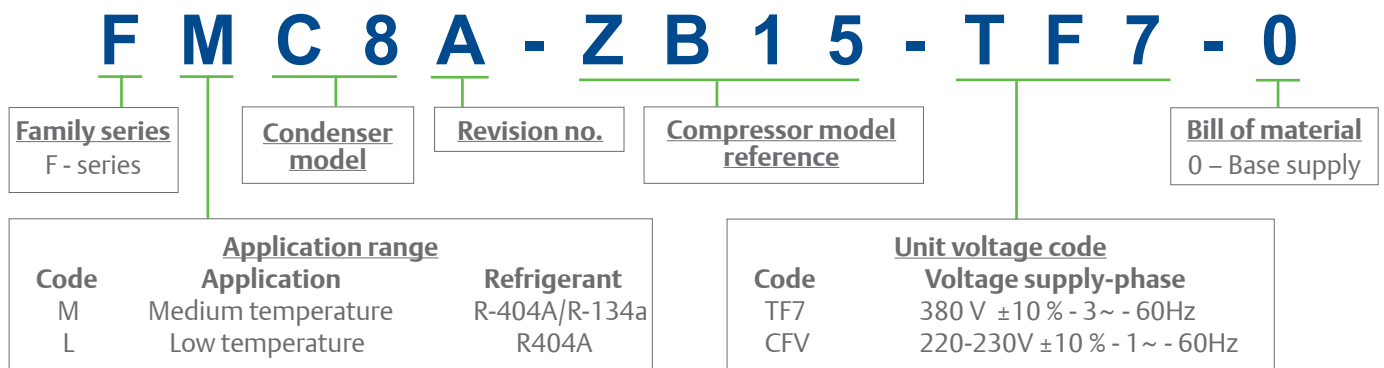

Scroll compressor features

Dual compliance

Compliance means sealing between the orbiting and fixed scroll involutes. Dual compliance means the sealing is on both the axial and radial directions, resulting in increased efficiency. This prevents refrigerant leak back across successive scroll pressure pockets. Compliance design also allows the scroll involutes to separate in both the radial and axial directions. This allows debris or liquid refrigerant to pass through the scroll involutes without damaging the compressor.

Axial Compliance Radial Compliance

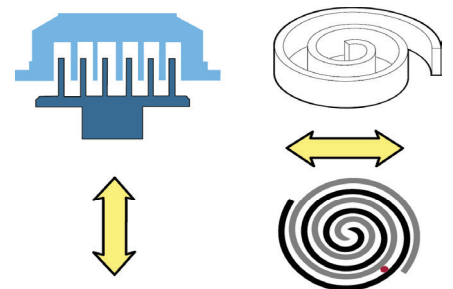

Scroll wear-in

The scroll involutes of Copeland Scroll compressor wear-in, rather than wear-out. So unlike in other compressor technologies among similar categories, there is no constant degradation of performance with time due to wear-out.

Lower sound, vibration and pulsation

The compression process in a scroll set is symmetrical and continuous. This inherently reduces the sound, vibration and pulsation. This eliminates the need for use of vibration absorbers and suction or discharge mufflers in most of the applications.



Performance data

Medium temperature

R404a

Condensing unit model (Number of fans)	Ambient (°C)	Capacity (kW)							Total power input (kW)						
		Evaporating temperature (°C)													
		-20	-15	-10	-5	0	5	7	-20	-15	-10	-5	0	5	7
FMH8A-ZB 15-TF7 (1)	32	2.92	3.57	4.28	5.06	5.91	6.81	7.19	2.21	2.22	2.23	2.24	2.26	2.30	2.32
	38	2.53	3.13	3.78	4.48	5.24	6.05	6.39	2.59	2.58	2.57	2.57	2.57	2.60	2.62
	43	2.18	2.74	3.33	3.97	4.66	5.39	5.69	2.98	2.96	2.93	2.90	2.89	2.90	2.91
	46	1.95	2.49	3.05	3.65	4.30	4.98	5.27	3.26	3.22	3.17	3.13	3.10	3.10	3.10
	49		2.22	2.76	3.32	3.93				3.51	3.45	3.39	3.34		
FMM8A-ZB 19-TF7 (1)	32	3.33	4.11	4.99	5.96	7.02	8.16	8.64	2.41	2.46	2.52	2.58	2.64	2.71	2.74
	38	2.97	3.68	4.48	5.36	6.32	7.36	7.79	2.69	2.75	2.80	2.87	2.93	3.00	3.03
	43	2.65	3.30	4.03	4.84	5.72	6.67	7.07	2.95	3.01	3.07	3.13	3.20	3.26	3.29
	46	2.45	3.07	3.75	4.51	5.34	6.24	6.62	3.12	3.18	3.24	3.30	3.37	3.44	3.46
	49		2.82	3.47	4.18	4.96	5.81			3.36	3.42	3.48	3.55	3.62	
FMM8A-ZB 21-TF7 (1)	32	4.34	5.20	6.18	7.26	8.43	9.66	10.16	2.98	3.07	3.16	3.24	3.34	3.45	3.50
	38	3.90	4.68	5.56	6.53	7.58	8.69	9.14	3.37	3.47	3.55	3.65	3.75	3.87	3.92
	43	3.54	4.24	5.04	5.92	6.86	7.87	8.28	3.72	3.82	3.91	4.01	4.11	4.24	4.30
	46	3.32	3.97	4.72	5.54	6.43	7.37		3.94	4.04	4.14	4.23	4.34	4.47	
	49		3.71	4.40	5.17					4.27	4.37	4.47			
FMR6A-ZB 26-TF7 (2)	32	5.12	6.20	7.39	8.70	10.12	11.63	12.26	3.43	3.53	3.63	3.75	3.86	3.98	4.03
	38	4.59	5.56	6.64	7.83	9.11	10.48	11.06	3.88	3.98	4.09	4.20	4.32	4.44	4.49
	43	4.13	5.01	5.99	7.07	8.24	9.50	10.02	4.30	4.40	4.51	4.62	4.74	4.86	4.91
	46	3.84	4.66	5.59	6.60	7.71	8.89	9.39	4.57	4.67	4.78	4.90	5.01	5.13	5.18
	49		4.31	5.17	6.12					4.96	5.07	5.19			
FMR7A-ZB 29-TF7 (2)	32	6.10	7.33	8.69	10.20	11.84	13.61	14.35	3.89	3.99	4.10	4.21	4.32	4.44	4.49
	38	5.51	6.63	7.86	9.22	10.71	12.31	12.99	4.38	4.48	4.59	4.70	4.82	4.94	4.99
	43	4.99	6.00	7.13	8.37	9.73	11.20	11.82	4.84	4.94	5.04	5.16	5.28	5.40	5.45
	46	4.66	5.62	6.68	7.85	9.13	10.52	11.11	5.14	5.23	5.34	5.45	5.57	5.69	5.74
	49		5.21	6.21	7.31					5.55	5.66	5.77			
FMS9A-ZB 38-TF7 (2)	32	7.68	9.22	10.94	12.82	14.88	17.10	18.03	4.80	4.93	5.06	5.21	5.36	5.51	5.57
	38	6.94	8.33	9.88	11.59	13.45	15.47	16.32	5.42	5.55	5.68	5.83	5.98	6.14	6.20
	43	6.27	7.55	8.97	10.52	12.22	14.07	14.85	6.00	6.12	6.26	6.41	6.56	6.72	6.78
	46	5.86	7.06	8.39	9.86	11.46	13.21	13.95	6.38	6.50	6.64	6.79	6.94	7.09	7.16
	49		6.55	7.80	9.18					6.90	7.04	7.18			
FMV9A-ZB 45-TF7 (2)	32	9.12	10.96	13.00	15.24	17.68	20.32	21.43	5.52	5.67	5.83	5.99	6.17	6.35	6.42
	38	8.24	9.90	11.75	13.78	15.99	18.39	19.40	6.24	6.39	6.55	6.72	6.90	7.08	7.15
	43	7.46	8.98	10.66	12.51	14.53	16.73	17.65	6.91	7.06	7.22	7.40	7.57	7.76	7.83
	46	6.96	8.40	9.98	11.72	13.63	15.71	16.58	7.36	7.50	7.66	7.83	8.01	8.19	8.26
	49		7.79	9.28	10.92					7.97	8.13	8.30			
FMV9A-ZB 48-TF7 (2)	32	9.92	11.89	14.08	16.47	19.07	21.87	23.04	6.12	6.30	6.49	6.69	6.90	7.11	7.20
	38	8.94	10.73	12.70	14.86	17.21	19.75	20.81	6.92	7.10	7.29	7.50	7.71	7.93	8.02
	43	8.07	9.70	11.50	13.47	15.61	17.92	18.90	7.68	7.85	8.05	8.25	8.46	8.69	8.77
	46	7.52	9.06	10.75	12.60	14.62	16.81		8.17	8.34	8.53	8.74	8.95	9.17	
	49		8.39	9.97	11.71					8.86	9.05	9.25			
FMV6A-ZB 58-TF7 (2)	32	11.77	14.33	17.07	20.06	23.33	26.93	28.46	7.49	7.72	7.98	8.26	8.53	8.81	8.91
	38	10.41	12.86	15.43	18.18	21.17	24.43	25.82	8.40	8.62	8.88	9.15	9.43	9.71	9.82
	43	9.11	11.49	13.93	16.50	19.26	22.26	23.54	9.25	9.47	9.72	9.99	10.27	10.54	10.65
	46	8.25	10.58	12.95	15.42	18.06	20.91	22.12	9.80	10.02	10.26	10.53	10.81	11.08	11.19
	49		9.62	11.92	14.30	16.81				10.60	10.84	11.11	11.38		
FMV6A-ZB 66-TF7 (2)	32	13.36	16.04	18.97	22.16	25.61	29.32	30.88	8.38	8.68	9.02	9.37	9.74	10.10	10.24
	38	12.07	14.52	17.16	20.02	23.11	26.43	27.82	9.35	9.65	9.99	10.33	10.69	11.04	11.17
	43	10.93	13.18	15.59	18.18	20.96	23.95	25.21	10.25	10.56	10.88	11.22	11.56	11.90	12.03
	46	10.20	12.34	14.61	17.03	19.64	22.44		10.84	11.14	11.47	11.80	12.13	12.45	
	49		11.47	13.60	15.86					11.77	12.08	12.41			

- Notes: 1. Operating Conditions: 20 °C Suction Gas Return Temperature and 0K Sub Cooling
 2. Stated power values are inclusive of fan power

Performance data

Medium temperature

R134a

Condensing unit model (Number of fans)	Ambient (°C)	Capacity (kW)							Total power input (kW)						
		Evaporating temperature (°C)													
		-15	-10	-5	0	5	7	10	-15	-10	-5	0	5	7	10
FMH8A-ZB 15-TF7 (1)	32	2.08	2.70	3.32	4.04	4.86	5.21	5.77	1.28	1.31	1.34	1.37	1.41	1.43	1.46
	38	1.93	2.44	3.11	3.79	4.55	4.88	5.41	1.42	1.45	1.48	1.52	1.57	1.58	1.61
	43	1.80	2.28	2.85	3.57	4.29	4.60	5.09	1.54	1.58	1.62	1.66	1.71	1.73	1.76
	46		2.18	2.73	3.43	4.13	4.43	4.90		1.66	1.71	1.75	1.80	1.82	1.85
	49		2.09	2.61	3.22	3.96	4.25	4.71		1.76	1.80	1.85	1.90	1.92	1.95
FMM8A-ZB 19-TF7 (1)	32	2.42	3.14	3.88	4.72	5.69	6.10	6.77	1.41	1.43	1.47	1.50	1.54	1.56	1.59
	38	2.25	2.84	3.63	4.43	5.33	5.73	6.35	1.56	1.59	1.63	1.67	1.71	1.73	1.76
	43	2.10	2.66	3.33	4.18	5.03	5.40	5.99	1.71	1.74	1.78	1.83	1.87	1.89	1.92
	46	2.01	2.55	3.19	4.02	4.84	5.20	5.77	1.80	1.84	1.88	1.93	1.98	2.00	2.03
	49		2.44	3.06	3.78	4.66	5.00	5.54		1.94	1.99	2.03	2.09	2.11	2.14
FMM8A-ZB 21-TF7 (1)	32	3.02	3.91	4.82	5.86	7.03	7.54	8.34	1.71	1.75	1.80	1.85	1.91	1.94	1.98
	38	2.80	3.53	4.51	5.48	6.58	7.06	7.81	1.90	1.95	2.00	2.06	2.13	2.15	2.20
	43	2.61	3.30	4.12	5.16	6.20	6.65	7.36	2.08	2.13	2.19	2.26	2.33	2.36	2.40
	46		3.16	3.95	4.97	5.97	6.40	7.08		2.26	2.32	2.39	2.46	2.49	2.54
	49		3.02	3.78	4.66	5.73	6.14	6.80		2.39	2.45	2.52	2.60	2.63	2.68
FMR6A-ZB 26-TF7 (2)	32	3.49	4.53	5.57	6.78	8.14	8.72	9.65	1.90	1.94	1.99	2.05	2.12	2.15	2.20
	38	3.23	4.09	5.22	6.35	7.62	8.17	9.05	2.12	2.17	2.23	2.29	2.37	2.40	2.45
	43	3.02	3.82	4.77	5.98	7.18	7.70	8.52	2.32	2.38	2.44	2.52	2.60	2.63	2.68
	46		3.66	4.57	5.75	6.91	7.41	8.20		2.52	2.59	2.67	2.75	2.78	2.83
	49		3.50	4.37	5.40	6.63	7.11	7.87		2.67	2.74	2.82	2.90	2.94	2.99
FMR7A-ZB 29-TF7 (2)	32	4.08	5.26	6.46	7.83	9.40	10.08	11.18	2.39	2.44	2.50	2.56	2.63	2.66	2.71
	38	3.76	4.74	6.03	7.32	8.80	9.44	10.47	2.67	2.72	2.78	2.84	2.92	2.95	3.00
	43	3.48	4.42	5.50	6.89	8.28	8.89	9.86	2.92	2.97	3.03	3.11	3.18	3.22	3.27
	46		4.22	5.27	6.62	7.97	8.55	9.48		3.14	3.20	3.28	3.36	3.39	3.44
	49		4.02	5.04	6.21	7.65	8.21	9.10		3.32	3.38	3.45	3.54	3.57	3.63
FMS9A-ZB 38-TF7 (2)	32	5.06	6.61	8.15	9.91	11.90	12.76	14.14	2.82	2.91	2.99	3.07	3.17	3.21	3.29
	38	4.69	5.99	7.65	9.30	11.16	11.97	13.26	3.14	3.23	3.32	3.40	3.51	3.56	3.64
	43	4.38	5.61	7.01	8.78	10.53	11.30	12.51	3.45	3.53	3.62	3.72	3.83	3.88	3.96
	46		5.38	6.74	8.46	10.15	10.88	12.05		3.74	3.83	3.93	4.04	4.09	4.17
	49		5.15	6.46	7.95	9.76	10.46	11.58		3.96	4.05	4.15	4.26	4.31	4.40
FMV9A-ZB 45-TF7 (2)	32	6.13	7.93	9.80	11.94	14.33	15.36	16.97	3.19	3.27	3.36	3.46	3.57	3.61	3.68
	38	5.65	7.14	9.15	11.17	13.43	14.39	15.91	3.57	3.65	3.76	3.86	3.98	4.03	4.10
	43	5.24	6.65	8.34	10.50	12.64	13.55	14.98	3.92	4.01	4.11	4.24	4.36	4.41	4.49
	46		6.35	7.98	10.09	12.15	13.03	14.41		4.25	4.36	4.48	4.61	4.66	4.74
	49		6.04	7.62	9.45	11.65	12.50	13.82		4.51	4.61	4.73	4.87	4.93	5.01
FMV9A-ZB 48-TF7 (2)	32	6.89	8.61	10.84	13.10	15.64	16.73	18.46	3.67	3.76	3.87	3.98	4.12	4.19	4.30
	38	6.38	8.01	10.15	12.27	14.65	15.67	17.29	4.12	4.22	4.34	4.46	4.60	4.67	4.79
	43	5.94	7.49	9.28	11.56	13.80	14.76	16.28	4.56	4.66	4.77	4.91	5.06	5.13	5.25
	46		7.17	8.90	11.12	13.27	14.20	15.66		4.95	5.06	5.20	5.36	5.43	5.55
	49		6.84	8.52	10.44	12.74	13.64	15.04		5.26	5.37	5.50	5.68	5.75	5.87
FMV6A-ZB 58-TF7 (2)	32	7.63	9.96	12.32	15.03	18.11	19.45	21.57	4.52	4.62	4.76	4.91	5.07	5.12	5.19
	38	7.00	8.92	11.48	14.04	16.96	18.23	20.25	5.02	5.12	5.28	5.44	5.60	5.65	5.72
	43	6.47	8.29	10.44	13.19	15.97	17.18	19.11	5.48	5.59	5.74	5.93	6.09	6.14	6.21
	46		7.91	9.99	12.67	15.36	16.54	18.41		5.88	6.04	6.24	6.40	6.46	6.53
	49		7.52	9.52	11.88	14.75	15.88	17.70		6.19	6.36	6.55	6.73	6.79	6.87
FMV6A-ZB 66-TF7 (2)	32	8.67	11.29	13.95	17.02	20.48	21.98	24.34	5.00	5.13	5.30	5.49	5.67	5.74	5.83
	38	7.95	10.09	12.98	15.88	19.16	20.58	22.83	5.56	5.69	5.89	6.09	6.28	6.35	6.44
	43	7.35	9.36	11.78	14.90	18.02	19.37	21.52	6.07	6.22	6.41	6.64	6.84	6.91	7.00
	46		8.92	11.26	14.30	17.32	18.63	20.71		6.55	6.75	6.99	7.20	7.27	7.36
	49		8.48	10.73	13.38	16.61	17.88	19.89		6.89	7.11	7.34	7.57	7.65	7.74

Notes: 1. Operating Conditions: 20 °C Suction Gas Return Temperature and 0K Sub Cooling
 2. Stated power values are inclusive of fan power

11 K Suction superheat

Performance data

Low temperature

R404a

Condensing unit model (Number of fans)	Ambient (°C)	Capacity (kW)							Total power input (kW)						
		Evaporating temperature (°C)													
		-40	-35	-30	-25	-20	-15	-10	-40	-35	-30	-25	-20	-15	-10
FLH7A-ZF 06-CFV (1)	32	1.38	1.75	2.15	2.60	3.09	3.64	4.25	1.72	1.75	1.82	1.93	2.08	2.24	2.42
	38	1.25	1.60	1.97	2.38	2.82	3.31	3.85	1.96	1.97	2.02	2.12	2.26	2.42	2.60
	43	1.16	1.49	1.83	2.20	2.59	3.03	3.51	2.16	2.15	2.20	2.28	2.41	2.56	2.74
	46	1.11	1.42	1.75	2.09	2.46	2.87	3.32	2.29	2.26	2.29	2.37	2.49	2.64	2.81
	49					2.34	2.71						2.57	2.71	
FLH8A-ZF 09-CFV (1)	32	1.96	2.46	3.01	3.62	4.31	5.07	5.92	2.23	2.31	2.41	2.53	2.69	2.87	3.07
	38	1.80	2.26	2.75	3.30	3.92	4.60	5.35	2.49	2.56	2.65	2.77	2.92	3.10	3.30
	43	1.66	2.07	2.52	3.02	3.57	4.19	4.86	2.73	2.79	2.88	3.00	3.14	3.32	3.52
	46	1.56	1.96	2.38	2.84	3.36	3.93	4.56	2.89	2.95	3.03	3.15	3.29	3.46	3.66
	49					3.14	3.67						3.44	3.61	
FLM8A-ZF 11-CFV (1)	32	2.46	3.07	3.77	4.55	5.43	6.40	7.48	2.61	2.72	2.87	3.04	3.25	3.49	3.76
	38	2.26	2.82	3.45	4.15	4.94	5.81	6.77	2.91	3.02	3.17	3.34	3.55	3.79	4.06
	43	2.08	2.59	3.16	3.79	4.50	5.28	6.14	3.18	3.30	3.45	3.63	3.83	4.07	4.34
	46	1.97	2.44	2.97	3.56	4.22	4.95	5.75	3.36	3.48	3.63	3.81	4.02	4.26	4.53
	49	1.84				3.93	4.60		3.55				4.21	4.45	
FLM8A-ZF 13-TF7 (1)	32	2.66	3.36	4.15	5.04	6.02	7.10	8.28	2.84	2.95	3.09	3.27	3.47	3.72	4.00
	38	2.46	3.07	3.76	4.55	5.43	6.40	7.46	3.17	3.29	3.43	3.61	3.82	4.06	4.34
	43	2.30	2.82	3.43	4.12	4.91	5.78	6.75	3.50	3.61	3.76	3.94	4.15	4.39	4.67
	46	2.21	2.67	3.22	3.86	4.58	5.40	6.31	3.71	3.83	3.98	4.15	4.36	4.61	4.89
	49														
FLR6A-ZF 13-TF7 (2)	32	2.70	3.42	4.24	5.16	6.20	7.34	8.59	2.77	2.87	3.01	3.17	3.37	3.60	3.86
	38	2.49	3.12	3.85	4.68	5.61	6.64	7.78	3.10	3.20	3.33	3.50	3.69	3.92	4.19
	43	2.33	2.88	3.52	4.25	5.09	6.03	7.07	3.41	3.51	3.65	3.81	4.01	4.24	4.51
	46	2.24	2.73	3.31	3.99	4.77	5.65	6.63	3.62	3.72	3.86	4.03	4.22	4.45	4.72
	49	2.15				4.44	5.26	6.18	3.84				4.45	4.68	4.94
FLR7A-ZF 15-TF7 (2)	32	3.43	4.29	5.26	6.36	7.60	8.99	10.53	3.51	3.69	3.89	4.13	4.40	4.71	5.07
	38	3.15	3.93	4.80	5.79	6.90	8.14	9.52	3.83	4.05	4.28	4.54	4.83	5.15	5.51
	43	2.90	3.61	4.40	5.29	6.28	7.40	8.63	4.12	4.38	4.64	4.93	5.23	5.57	5.94
	46	2.74	3.41	4.14	4.97	5.90	6.93	8.09	4.31	4.59	4.88	5.18	5.50	5.84	6.22
	49	2.58	3.20			5.50	6.46	7.53	4.50	4.81			5.77	6.13	6.51
FLS9A-ZF 18-TF7 (2)	32	4.13	5.19	6.37	7.69	9.18	10.84	12.69	4.16	4.30	4.51	4.79	5.12	5.50	5.92
	38	3.83	4.80	5.87	7.05	8.37	9.86	11.51	4.55	4.70	4.92	5.20	5.53	5.92	6.35
	43	3.57	4.46	5.42	6.49	7.67	9.01	10.50	4.90	5.05	5.28	5.57	5.91	6.30	6.75
	46	3.41	4.25	5.15	6.14	7.24	8.48	9.87	5.12	5.28	5.51	5.80	6.15	6.55	6.99
	49	3.25	4.03			6.80	7.94	9.23	5.35	5.52			6.40	6.80	7.25

- Notes: 1. Operating Conditions: 20 °C Suction Gas Return Temperature and 0K Sub Cooling
 2. Stated power values are inclusive of fan power

Dimensional diagram

Medium temperature single fan model

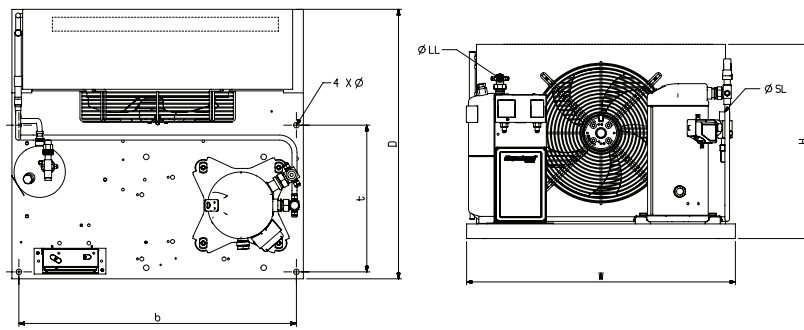

Medium temperature double fan model

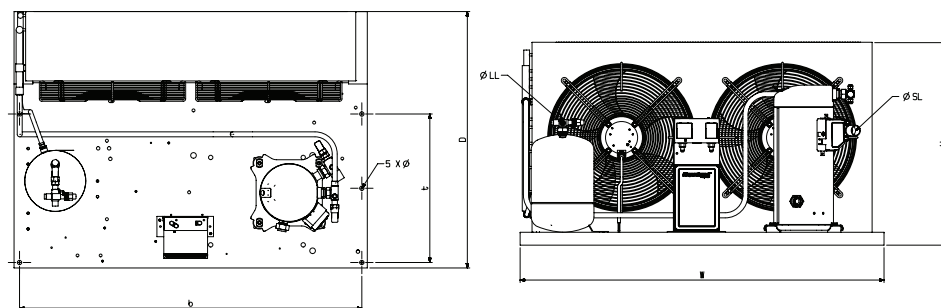

Low temperature single fan model

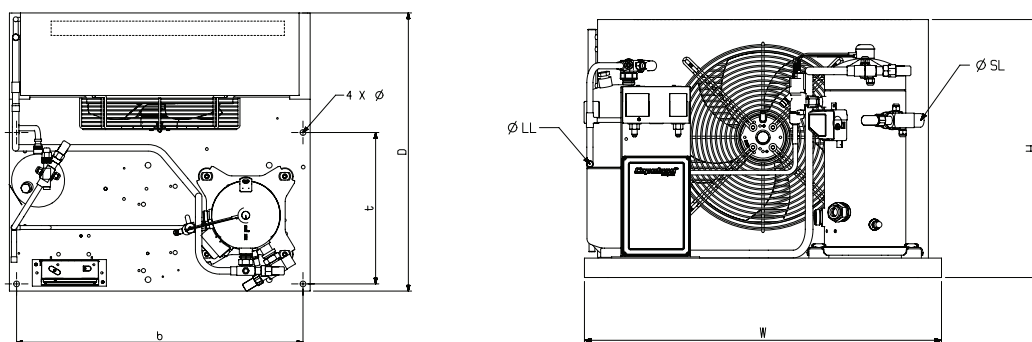

Low temperature double fan model

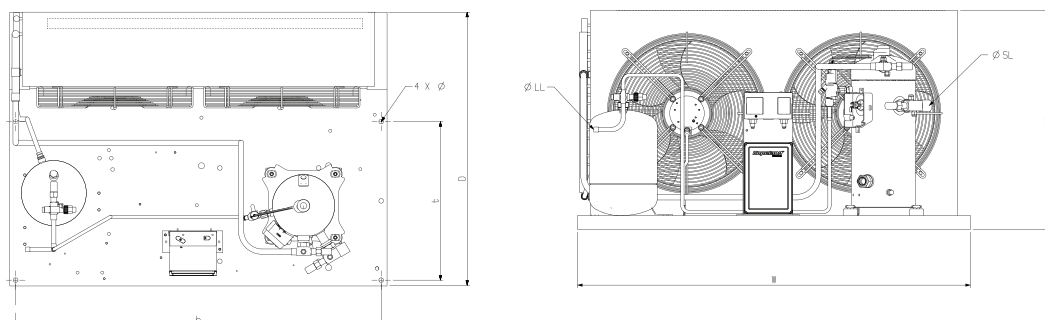

Mechanical data

Condensing unit model	Compressor model	Receiver capacity (l)	Air flow (m ³ /s)	Depth/width [D/W] (mm)	Height [H] (mm)	Base mounting Ø [b/t] (mm)	Suction Ø [SL] (")	Liquid Ø [LL] (")	Net weight (kg)	Gross weight (kg)
FMH8A-ZB 15-TF7	ZB15KQE-TF7-559	7.9	1.00	680/735	531	700 x 370 (14)	3/4	1/2	64	79
FMM8A-ZB 19-TF7	ZB19KQE-TF7-559	7.9	0.92	730/735	708	700 x 390 (14)	7/8	1/2	74	91
FMM8A-ZB 21-TF7	ZB21KQE-TF7-559	7.9	0.92	730/735	708	700 x 390 (14)	7/8	1/2	74	91
FMR6A-ZB 26-TF7	ZB26KQE-TF7-559	7.9	1.41	820/1130	630	1095 x 475 (14)	7/8	1/2	95	135
FMR7A-ZB 29-TF7	ZB29KQE-TF7-559	7.9	1.97	820/1130	630	1095 x 475 (14)	1 1/8	1/2	99	139
FMS9A-ZB 38-TF7	ZB38KQE-TF7-559	11.7	1.94	820/1130	706	1095 x 475 (14)	1 1/8	5/8	115	155
FMV9A-ZB 45-TF7	ZB45KQE-TF7-559	11.7	2.18	820/1330	832	1295 x 475 (14)	1 1/8	5/8	128	208
FMV9A-ZB 48-TF7	ZB48KQE-TF7-559	15.8	2.18	820/1330	832	1295 x 475 (14)	1 1/8	3/4	129	209
FMV6A-ZB 58-TF7	ZB58KQE-TF7-551	15.8	2.97	820/1330	832	1295 x 475 (14)	1 3/8	3/4	164	244
FMV6A-ZB 66-TF7	ZB66KQE-TF7-551	15.8	2.97	820/1330	832	1295 x 475 (14)	1 3/8	3/4	166	246
FLH7A-ZF 06-CFV	ZF06K4E-PFV-551	3.9	0.72	680/735	531	700 x 370 (14)	3/4	1/2	67	82
FLH8A-ZF 09-CFV	ZF09K4E-PFV-551	7.9	1.00	680/735	531	700 x 370 (14)	3/4	1/2	68	83
FLM8A-ZF 11-CFV	ZF11K4E-PFV-551	7.9	0.92	730/735	708	700 x 390 (14)	7/8	1/2	76	93
FLM8A-ZF 13-TF7	ZF13KQE-TF7-551	7.9	0.92	730/735	708	700 x 390 (14)	7/8	1/2	87	104
FLR6A-ZF 13-TF7	ZF13KQE-TF7-551	7.9	1.41	820/1130	630	1095 x 475 (14)	7/8	1/2	106	146
FLR7A-ZF 15-TF7	ZF15KQE-TF7-551	7.9	1.97	820/1130	630	1095 x 475 (14)	1 1/8	1/2	106	146
FLS9A-ZF 18-TF7	ZF18KQE-TF7-551	11.7	1.94	820/1130	706	1095 x 475 (14)	1 1/8	5/8	118	158

Electrical data

Condensing unit model	Compressor model	Compressor maximum operating current (A)	Compressor locked rotor current (A)	Condenser fan 230V/1/60Hz (Qty x model)	Condenser fan current Vendor A/B (A)
FMH8A-ZB 15-TF7	ZB15KQE-TF7-559	5.1	27	1 x 271	1.40 / 1.68
FMM8A-ZB 19-TF7	ZB19KQE-TF7-559	6.0	30	1 x 271	1.40 / 1.68
FMM8A-ZB 21-TF7	ZB21KQE-TF7-559	7.2	39	1 x 271	1.40 / 1.68
FMR6A-ZB 26-TF7	ZB26KQE-TF7-559	8.8	41	2 x 121	0.65 / 0.72
FMR7A-ZB 29-TF7	ZB29KQE-TF7-559	10.0	54	2 x 271	1.40 / 1.68
FMS9A-ZB 38-TF7	ZB38KQE-TF7-559	13.0	64	2 x 271	1.40 / 1.68
FMV9A-ZB 45-TF7	ZB45KQE-TF7-559	13.1	70	2 x 271	1.40 / 1.68
FMV9A-ZB 48-TF7	ZB48KQE-TF7-559	15.0	100	2 x 271	1.40 / 1.68
FMV6A-ZB 58-TF7	ZB58KQE-TF7-551	19.0	123	2 x 611	2.25 / 3.20
FMV6A-ZB 66-TF7	ZB66KQE-TF7-551	21.2	140	2 x 611	2.25 / 3.20
FLH7A-ZF 06-CFV	ZF06K4E-PFV-551	17.1	61	1 x 121	0.65 / 0.72
FLH8A-ZF 09-CFV	ZF09K4E-PFV-551	20.2	88	1 x 271	1.40 / 1.68
FLM8A-ZF 11-CFV	ZF11K4E-PFV-551	24.7	109	1 x 271	1.40 / 1.68
FLM8A-ZF 13-TF7	ZF13KQE-TF7-551	10.0	57	1 x 271	1.40 / 1.68
FLR6A-ZF 13-TF7	ZF13KQE-TF7-551	10.0	57	2 x 121	0.65 / 0.72
FLR7A-ZF 15-TF7	ZF15KQE-TF7-551	12.0	64	2 x 271	1.40 / 1.68
FLS9A-ZF 18-TF7	ZF18KQE-TF7-551	14.0	70	2 x 271	1.40 / 1.68

About Emerson

Emerson (NYSE: EMR), headquartered in St. Louis, Missouri (USA), is a global technology and engineering company providing innovative solutions for customers in industrial, commercial, and residential markets. Our Emerson Automation Solutions business helps process, hybrid, and discrete manufacturers maximize production, protect personnel and the environment while optimizing their energy and operating costs. Our Emerson Commercial and Residential Solutions business helps ensure human comfort and health, protect food quality and safety, advance energy efficiency, and create sustainable infrastructure. For more information visit Emerson.com.



Emerson.com

Emerson, Copeland Scroll are trademarks of Emerson Electric Co. or one of its affiliated companies.
©2018 Emerson Climate Technologies, Inc. All rights reserved.

