

Copeland Scroll™ ZSI Compressor



Product catalogue



Pioneering technologies for best-in-class products

Emerson is the world's leading provider of heating, ventilation, air conditioning and refrigeration solutions for residential, commercial and industrial applications, supporting the industry with advanced technology, technical support and training services.

For more than 80 years, we have been introducing innovative technology to the market, from the first semi-hermetic and hermetic compressors in the 1940s and 1950s, the high efficiency Discus™ semi-hermetic, air conditioning and heating scroll compressors in the 1980s and 1990s, to the new Stream semi-hermetic and the digital scroll compressor technology of today.

Based on this, we have developed an unequalled range of solutions for the refrigeration and air conditioning markets. In recent years, we have become a major solution provider to the air conditioning and refrigeration industry. Our range of Copeland™ brand products addresses the diverse needs of all of these markets. With scrolls and semi-hermetic compressors available for all main refrigerants, equipped with smart electronics and capable of modulation, Emerson has taken compressor technology to new heights.

Our vision

Emerson, with our partners,
will provide global solutions to improve human comfort,
safeguard food and protect the environment.



Index

Introduction	04
ZSI with CoreSense	04
Nomenclature	05
Bill of material	05
Product line-up	06
Operating envelope	06
Performance table (kW) – R22	07
Performance table (kW) – R404A	10
Technical data	13
Application guide	14
Dimensional drawings	23
Wiring diagram	26
Contact list	28

ZSI with CoreSense™

ZSI Scroll compressor design benefits

Emerson's launch of scroll products revolutionized the industry and the company continues to innovate the technology leading it to what it is today:

- Design has inherent higher efficiency translating to annual electrical savings
- Fewer moving parts compared to traditional piston compressors, thus making it more reliable
- Continuous compression provides lower vibration and quieter operation
- Improved liquid handling capability due to axial and radial compliance technology
- No complex internal suction and discharge valves for quieter operation and higher reliability

Liquid injection technology controlled by CoreSense

The ZSI Scroll Compressor features Liquid Injection Technology controlled by an intelligent electronics platform—the CoreSense Control Board—which regulates liquid injection by sensing the Discharge Line Temperature (DLT). This combination both widens the operating envelope and enhances the product reliability. The CoreSense Control Board also features LED display that alerts the user of sensor status and Electronic Expansion Valve (EEV) operation. This is Emerson's "smart compressor" strategy—allowing compressor protection, DLT and EEV status alert leading to less compressor downtime, thus providing more value to its customers.

ZSI scroll compressor key product advantages

Scroll efficiency and reliability

- COP improvement leads to annual electrical savings of 10%–30% or about \$100–\$500 per year as compared with reciprocating systems depending on model
- Has fewer moving parts than reciprocating compressors, thus making it more reliable
- Improved liquid handling capability due to axial and radial compliance technology

Smooth scroll movement

- Low sound and vibration leading to quieter operation
- No complex internal suction and discharge valves for higher reliability

Wide range operating envelope

- From -30°C to 0°C evaporating temperature
- Low temperature operation reliability due to liquid injection technology controlled by CoreSense
- Reduced inventory levels due to wide range application

CoreSense

- Liquid Injection Technology—controlled by CoreSense—protects the compressor from high discharge temperature failure
- Onboard control for Liquid Injection by sensing Discharge Line Temperature (DLT)
- LED display alerts user of DLT sensor status and EXV operation enabling easier troubleshooting



Nomenclature

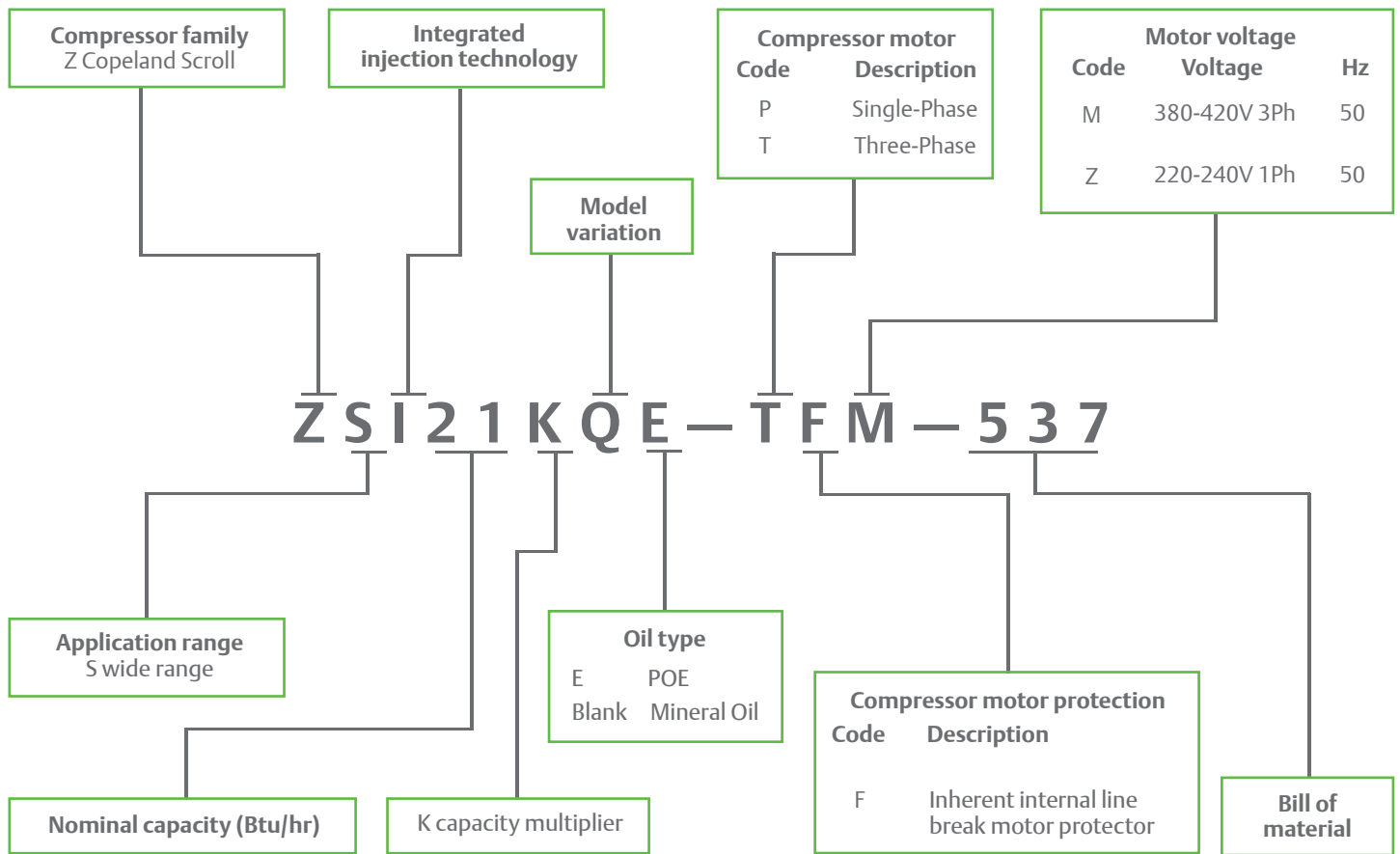

Bill of material

Compressor model	Motor code	BOM	Stub tube connection	Oil sight glass	CoreSense module
ZSI06KQ/E	PFZ, TFM	527	✓	✓	✓
ZSI08KQ/E	PFZ, TFM		✓	✓	✓
ZSI09KQ/E	TFM		✓	✓	✓
ZSI11KQ/E	TFM	527	✓	✓	✓
ZSI14KQ/E	TFM		✓	✓	✓
ZSI15KQ/E	TFM		✓	✓	✓
ZSI18KQ/E	TFM	537	✓	✓	✓
ZSI21KQ/E	TFM		✓	✓	✓

Note: CoreSense module includes control board, transformer, EXV, discharge temperature sensor, etc.

Product line-up

Capacity, kW

R404A - 50Hz

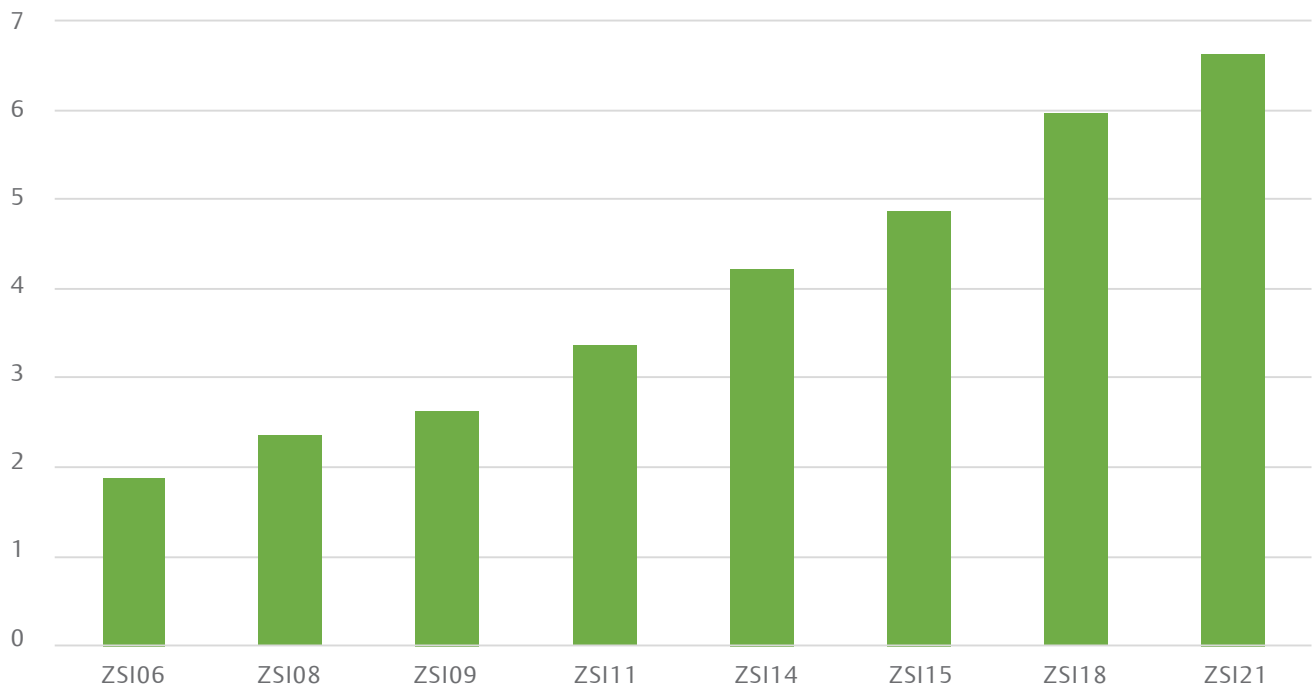

Notes: Low Temperature cold room conditions: -25°C Evaporating temp, 45°C Condensing temp, 20°C Return gas and 0 K Sub-cooling

Operating envelope

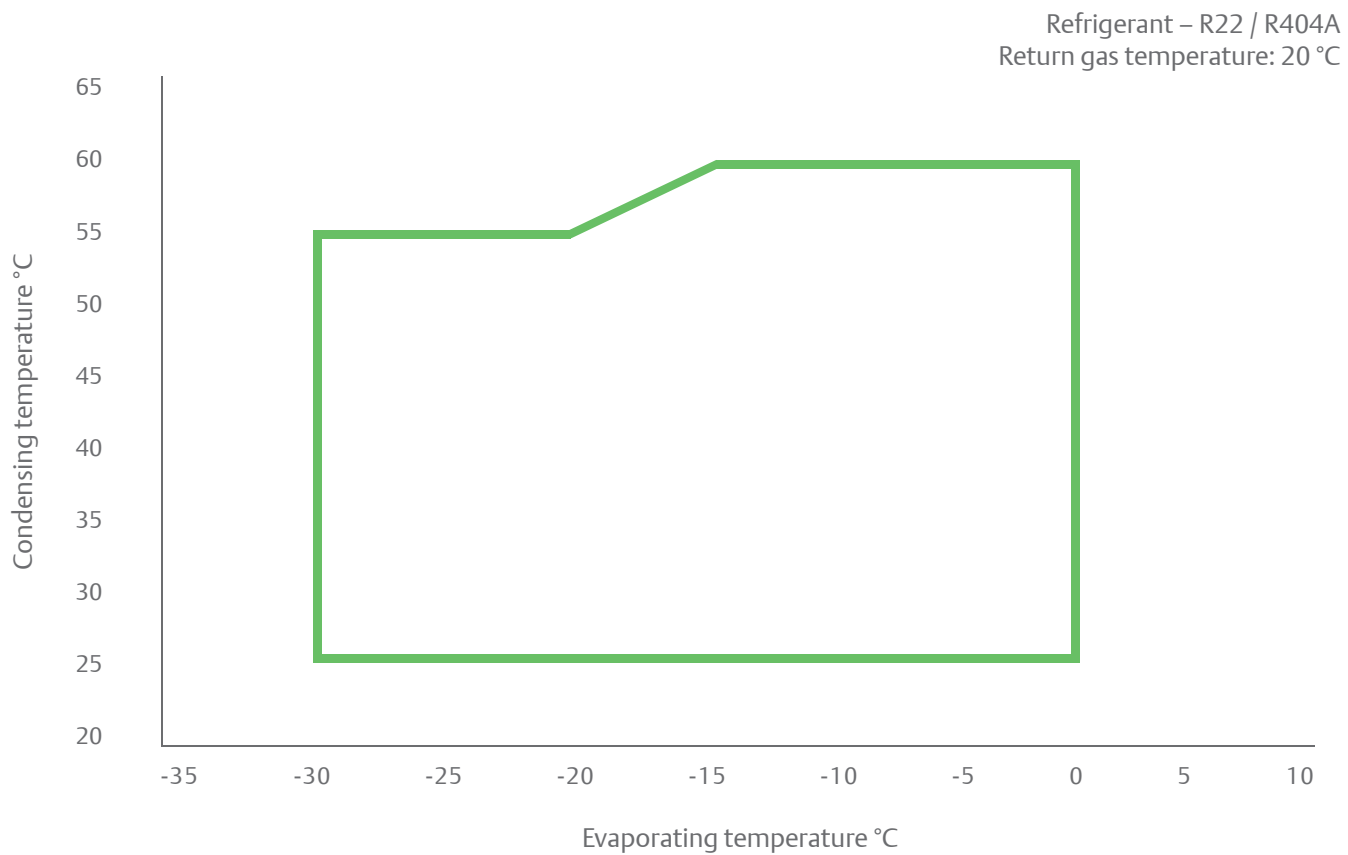

Performance table

PFZ: 220 - 240 V ; 1-Phase, 50Hz

R22

Model		Cond. temp. °C	Evap. temp. °C						
			-30	-25	-20	-15	-10	-5	0
ZSI06KQ	Q	60				2.42	2.91	3.50	4.22
		55	1.37	1.78	2.19	2.63	3.15	3.77	4.54
		50	1.48	1.89	2.32	2.78	3.32	3.98	4.79
		45	1.54	1.96	2.39	2.88	3.46	4.15	5.01
		40	1.57	2.00	2.45	2.97	3.57	4.31	5.21
		35	1.61	2.05	2.52	3.06	3.70	4.48	5.44
		30	1.67	2.13	2.63	3.20	3.88	4.70	5.71
	P	25	1.80	2.28	2.80	3.40	4.12	4.99	6.06
		60				2.27	2.30	2.31	2.30
		55	1.94	1.99	2.03	2.06	2.08	2.09	2.08
		50	1.75	1.80	1.83	1.86	1.87	1.87	1.86
		45	1.58	1.61	1.64	1.66	1.67	1.66	1.65
		40	1.42	1.44	1.46	1.48	1.48	1.48	1.46
		35	1.28	1.30	1.31	1.32	1.32	1.32	1.30
ZSI08KQ	Q	30	1.16	1.18	1.19	1.19	1.20	1.19	1.17
		25	1.08	1.09	1.10	1.11	1.11	1.10	1.09
		60				2.79	3.44	4.16	4.94
		55	1.56	1.91	2.39	2.97	3.65	4.40	5.21
		50	1.69	2.06	2.56	3.17	3.88	4.66	5.50
		45	1.81	2.21	2.74	3.37	4.11	4.92	5.79
		40	1.92	2.35	2.90	3.57	4.33	5.18	6.09
	P	35	2.01	2.46	3.05	3.74	4.54	5.43	6.38
		30	2.07	2.55	3.16	3.90	4.73	5.65	6.65
		25	2.09	2.60	3.25	4.02	4.89	5.85	6.89
		60				2.66	2.70	2.73	2.75
		55	2.28	2.33	2.38	2.42	2.44	2.47	2.48
		50	2.07	2.12	2.16	2.20	2.22	2.24	2.25
		45	1.89	1.94	1.98	2.01	2.03	2.04	2.05
ZSI11KQ	Q	40	1.73	1.77	1.81	1.84	1.86	1.88	1.88
		35	1.58	1.63	1.67	1.70	1.72	1.73	1.74
		30	1.45	1.51	1.55	1.58	1.60	1.61	1.62
		25	1.34	1.40	1.44	1.48	1.50	1.52	1.52
		60				4.17	5.04	6.05	7.23
		55	2.33	2.88	3.52	4.27	5.16	6.20	7.42
		50	2.48	3.03	3.69	4.46	5.38	6.47	7.76
	P	45	2.64	3.21	3.90	4.72	5.69	6.85	8.22
		40	2.80	3.41	4.14	5.02	6.07	7.32	8.78
		35	2.94	3.61	4.41	5.37	6.51	7.86	9.44
		30	3.04	3.78	4.67	5.73	6.98	8.45	10.17
		25	3.09	3.92	4.92	6.09	7.47	9.09	10.95
		60				3.89	3.91	3.91	3.89
		55	3.13	3.21	3.27	3.31	3.34	3.34	3.33
ZSI14KQ	Q	50	2.75	2.82	2.88	2.92	2.94	2.96	2.96
		45	2.49	2.56	2.61	2.65	2.69	2.71	2.73
		40	2.30	2.36	2.41	2.46	2.50	2.54	2.58
		35	2.13	2.18	2.24	2.29	2.35	2.40	2.46
		30	1.92	1.97	2.04	2.10	2.17	2.24	2.32
		25	1.62	1.68	1.75	1.82	1.91	2.00	2.11
		60				5.35	6.41	7.65	9.13
	P	55	2.83	3.67	4.54	5.51	6.61	7.92	9.49
		50	2.98	3.84	4.74	5.75	6.93	8.31	9.98
		45	3.17	4.05	5.00	6.07	7.32	8.81	10.58
		40	3.35	4.28	5.29	6.43	7.78	9.37	11.27
		35	3.51	4.50	5.58	6.82	8.27	9.99	12.03
		30	3.64	4.70	5.87	7.21	8.79	10.64	12.84
		25	3.70	4.84	6.12	7.58	9.29	11.30	13.67

Notes:

1. Q for capacity; P for power. Units in kW
2. All ZSI values are rated at return gas temperature: 20°C and subcooling: 0 K

Performance table

TFM: 380 - 420 V ; 3-Phase, 50Hz

R22

Model		Cond. temp. °C	Evap. temp. °C						
			-30	-25	-20	-15	-10	-5	0
ZSI06KQ	Q	60				2.29	2.82	3.44	4.15
		55	1.26	1.59	1.98	2.46	3.02	3.67	4.41
		50	1.38	1.71	2.12	2.62	3.21	3.89	4.67
		45	1.48	1.82	2.26	2.78	3.39	4.11	4.93
		40	1.57	1.93	2.38	2.92	3.57	4.32	5.19
		35	1.64	2.01	2.49	3.06	3.74	4.54	5.45
		30	1.69	2.09	2.59	3.19	3.91	4.75	5.70
	P	25	1.73	2.15	2.68	3.32	4.07	4.95	5.96
		60				2.29	2.33	2.34	2.32
		55	1.80	1.92	2.01	2.07	2.10	2.10	2.08
		50	1.64	1.74	1.82	1.86	1.88	1.88	1.86
		45	1.49	1.57	1.63	1.67	1.68	1.68	1.65
		40	1.34	1.41	1.46	1.49	1.50	1.49	1.47
		35	1.20	1.26	1.30	1.32	1.33	1.32	1.30
ZSI08KQ	Q	30	1.07	1.12	1.15	1.17	1.17	1.17	1.16
		25	0.95	0.99	1.01	1.02	1.03	1.03	1.03
		60				2.80	3.43	4.15	5.01
		55	1.58	2.01	2.49	3.05	3.69	4.45	5.35
		50	1.71	2.16	2.65	3.23	3.91	4.70	5.64
		45	1.80	2.26	2.78	3.38	4.09	4.93	5.90
		40	1.86	2.34	2.89	3.52	4.26	5.14	6.16
	P	35	1.92	2.42	2.99	3.66	4.44	5.36	6.44
		30	1.99	2.51	3.11	3.82	4.64	5.61	6.74
		25	2.08	2.63	3.27	4.02	4.89	5.91	7.09
		60				2.59	2.62	2.63	2.61
		55	2.22	2.28	2.33	2.37	2.40	2.41	2.39
		50	1.99	2.04	2.08	2.12	2.14	2.15	2.14
		45	1.75	1.78	1.82	1.85	1.87	1.87	1.87
ZSI09KQ	Q	40	1.51	1.54	1.56	1.59	1.61	1.62	1.62
		35	1.32	1.33	1.35	1.37	1.39	1.41	1.41
		30	1.18	1.19	1.20	1.22	1.24	1.26	1.28
		25	1.13	1.13	1.14	1.16	1.19	1.21	1.24
		60				3.00	3.69	4.52	5.50
		55	1.65	2.10	2.63	3.26	4.00	4.87	5.90
		50	1.77	2.26	2.82	3.49	4.27	5.20	6.28
	P	45	1.87	2.39	2.99	3.69	4.52	5.49	6.63
		40	1.96	2.51	3.14	3.88	4.76	5.78	6.97
		35	2.05	2.62	3.29	4.07	4.98	6.05	7.30
		30	2.14	2.74	3.44	4.26	5.21	6.33	7.62
		25	2.24	2.87	3.60	4.45	5.45	6.61	7.96
		60				2.88	2.92	2.95	2.96
		55	2.44	2.48	2.52	2.57	2.60	2.63	2.63
ZSI11KQ	Q	50	2.18	2.21	2.25	2.29	2.33	2.35	2.34
		45	1.96	1.98	2.02	2.05	2.08	2.10	2.10
		40	1.76	1.78	1.81	1.84	1.87	1.89	1.88
		35	1.58	1.60	1.63	1.66	1.69	1.70	1.70
		30	1.41	1.43	1.46	1.50	1.53	1.55	1.54
		25	1.26	1.28	1.32	1.35	1.38	1.40	1.41
		60				3.96	4.82	5.85	7.08
	P	55	2.25	2.78	3.42	4.18	5.10	6.19	7.48
		50	2.39	2.96	3.63	4.44	5.40	6.55	7.90
		45	2.55	3.15	3.86	4.71	5.72	6.93	8.35
		40	2.72	3.34	4.09	4.98	6.05	7.31	8.80
		35	2.88	3.53	4.31	5.25	6.37	7.69	9.24
		30	3.02	3.70	4.52	5.51	6.67	8.05	9.66
		25	3.13	3.84	4.70	5.73	6.95	8.38	10.05
ZSI11KQ	Q	60				3.55	3.58	3.59	3.60
		55	2.89	2.96	3.02	3.07	3.11	3.14	3.16
		50	2.53	2.61	2.67	2.73	2.77	2.82	2.85
		45	2.30	2.37	2.43	2.49	2.54	2.59	2.63
		40	2.12	2.19	2.25	2.30	2.36	2.41	2.46
		35	1.97	2.02	2.07	2.12	2.17	2.23	2.28
		30	1.79	1.83	1.87	1.91	1.95	2.00	2.05
	P	25	1.53	1.55	1.58	1.60	1.64	1.67	1.72

Notes:

1. Q for capacity; P for power. Units in kW
2. All ZSI values are rated at return gas temperature: 20°C and subcooling: 0 K

Performance table

TFM: 380 - 420 V ; 3-Phase, 50Hz

R22

Model		Cond. temp. °C	Evap. temp. °C						
			-30	-25	-20	-15	-10	-5	0
ZSI14KQ	Q	60				5.14	6.19	7.44	8.95
		55	2.75	3.56	4.43	5.40	6.53	7.87	9.48
		50	2.90	3.75	4.67	5.70	6.90	8.33	10.04
		45	3.08	3.97	4.94	6.03	7.31	8.82	10.63
		40	3.27	4.19	5.21	6.36	7.71	9.31	11.22
		35	3.45	4.41	5.47	6.69	8.11	9.80	11.80
		30	3.60	4.60	5.71	6.99	8.48	10.25	12.34
	25	3.71	4.75	5.90	7.24	8.80	10.65	12.85	
	P	60				4.38	4.48	4.52	4.50
		55	3.58	3.67	3.78	3.89	3.98	4.02	3.99
		50	3.19	3.26	3.36	3.46	3.54	3.58	3.56
		45	2.84	2.90	2.99	3.08	3.16	3.20	3.18
		40	2.53	2.58	2.66	2.75	2.82	2.87	2.85
		35	2.26	2.30	2.37	2.45	2.53	2.58	2.57
30		2.01	2.04	2.11	2.19	2.27	2.32	2.33	
25	1.78	1.80	1.87	1.96	2.04	2.10	2.12		
ZSI15KQ	Q	60				5.74	6.88	8.25	9.85
		55	3.34	4.07	4.95	6.00	7.26	8.74	10.47
		50	3.48	4.28	5.24	6.38	7.73	9.33	11.18
		45	3.71	4.57	5.60	6.82	8.27	9.97	11.94
		40	3.96	4.88	5.98	7.28	8.82	10.62	12.70
		35	4.21	5.17	6.33	7.71	9.33	11.22	13.42
		30	4.39	5.40	6.61	8.06	9.76	11.74	14.04
	25	4.46	5.51	6.78	8.28	10.06	12.13	14.53	
	P	60				4.80	4.90	5.00	5.10
		55	3.97	4.05	4.14	4.25	4.35	4.46	4.57
		50	3.50	3.60	3.70	3.81	3.92	4.03	4.14
		45	3.14	3.24	3.34	3.45	3.56	3.68	3.78
		40	2.84	2.94	3.04	3.15	3.26	3.37	3.47
		35	2.58	2.67	2.77	2.87	2.97	3.07	3.16
30		2.32	2.41	2.49	2.58	2.67	2.76	2.83	
25	2.04	2.11	2.18	2.25	2.32	2.39	2.44		
ZSI18KQ	Q	60				6.95	8.43	10.13	12.06
		55	3.99	4.91	6.03	7.38	8.95	10.76	12.82
		50	4.26	5.22	6.41	7.83	9.50	11.42	13.59
		45	4.53	5.54	6.79	8.29	10.05	12.07	14.37
		40	4.80	5.85	7.16	8.74	10.59	12.72	15.13
		35	5.03	6.13	7.50	9.15	11.09	13.33	15.87
		30	5.22	6.36	7.79	9.52	11.55	13.89	16.55
	25	5.34	6.53	8.02	9.82	11.94	14.39	17.17	
	P	60				6.01	6.12	6.21	6.28
		55	5.05	5.23	5.38	5.49	5.58	5.65	5.71
		50	4.55	4.69	4.80	4.89	4.96	5.03	5.08
		45	4.01	4.12	4.20	4.27	4.33	4.39	4.44
		40	3.49	3.57	3.63	3.68	3.74	3.80	3.87
		35	3.05	3.10	3.15	3.20	3.25	3.32	3.40
30		2.75	2.78	2.82	2.87	2.93	3.01	3.12	
25	2.65	2.67	2.70	2.75	2.83	2.93	3.07		
ZSI21KQ	Q	60				7.78	9.52	11.47	13.62
		55	4.40	5.48	6.80	8.38	10.18	12.22	14.48
		50	4.82	5.89	7.24	8.86	10.75	12.89	15.28
		45	5.12	6.20	7.59	9.28	11.25	13.51	16.04
		40	5.35	6.46	7.89	9.65	11.73	14.12	16.80
		35	5.55	6.69	8.18	10.03	12.22	14.75	17.60
		30	5.74	6.92	8.49	10.44	12.76	15.44	18.47
	25	5.96	7.21	8.86	10.92	13.38	16.22	19.45	
	P	60				6.52	6.67	6.79	6.86
		55	5.44	5.54	5.68	5.82	5.96	6.07	6.15
		50	4.89	4.97	5.09	5.23	5.36	5.47	5.55
		45	4.41	4.49	4.60	4.72	4.85	4.97	5.05
		40	4.00	4.06	4.16	4.29	4.42	4.53	4.62
		35	3.62	3.68	3.77	3.90	4.03	4.15	4.25
30		3.26	3.31	3.40	3.52	3.66	3.79	3.90	
25	2.90	2.94	3.03	3.15	3.29	3.43	3.55		

Notes:

1. Q for capacity; P for power. Units in kW
2. All ZSI values are rated at return gas temperature: 20°C and subcooling: 0 K

Performance table

PFZ: 220 - 240 V ; 1-Phase, 50Hz

R404A

Model		Cond. temp. °C	Evap. temp. °C						
			-30	-25	-20	-15	-10	-5	0
ZSI06KQE	Q	60				2.25	2.71	3.24	3.85
		55	1.35	1.67	2.04	2.49	3.00	3.60	4.30
		50	1.48	1.84	2.26	2.75	3.33	4.00	4.77
		45	1.63	2.03	2.49	3.04	3.68	4.41	5.25
		40	1.79	2.22	2.73	3.32	4.01	4.81	5.72
		35	1.93	2.39	2.94	3.58	4.33	5.19	6.17
		30	2.04	2.53	3.11	3.80	4.60	5.52	6.56
	25	2.10	2.61	3.23	3.96	4.81	5.79	6.90	
	P	60				2.47	2.49	2.49	2.47
		55	2.04	2.08	2.13	2.16	2.18	2.18	2.17
		50	1.83	1.88	1.92	1.96	1.98	1.99	1.97
		45	1.70	1.75	1.79	1.83	1.86	1.86	1.85
		40	1.60	1.65	1.69	1.73	1.76	1.77	1.75
		35	1.49	1.54	1.59	1.63	1.66	1.66	1.65
30		1.34	1.39	1.44	1.48	1.50	1.51	1.50	
ZSI08KQE	Q	60				2.67	3.22	3.85	4.58
		55	1.57	1.97	2.43	2.96	3.58	4.29	5.11
		50	1.73	2.17	2.68	3.27	3.96	4.75	5.66
		45	1.91	2.39	2.95	3.59	4.35	5.21	6.21
		40	2.09	2.60	3.20	3.91	4.72	5.66	6.74
		35	2.24	2.79	3.44	4.19	5.07	6.08	7.24
		30	2.36	2.94	3.63	4.43	5.37	6.46	7.69
	25	2.42	3.03	3.76	4.62	5.61	6.76	8.07	
	P	60				2.84	2.84	2.84	2.86
		55	2.49	2.55	2.58	2.59	2.60	2.61	2.64
		50	2.24	2.31	2.35	2.37	2.38	2.40	2.43
		45	2.02	2.09	2.14	2.16	2.18	2.20	2.24
		40	1.83	1.90	1.95	1.98	1.99	2.01	2.05
		35	1.66	1.74	1.79	1.81	1.83	1.85	1.88
30		1.53	1.61	1.65	1.67	1.68	1.70	1.73	
ZSI11KQE	Q	60				3.79	4.52	5.41	6.50
		55	2.27	2.89	3.53	4.25	5.09	6.09	7.31
		50	2.47	3.15	3.87	4.67	5.61	6.73	8.08
		45	2.65	3.39	4.18	5.07	6.10	7.34	8.81
		40	2.83	3.62	4.48	5.45	6.58	7.91	9.50
		35	3.01	3.85	4.77	5.82	7.04	8.48	10.18
		30	3.21	4.10	5.08	6.20	7.51	9.04	10.86
	25	3.44	4.37	5.41	6.60	7.98	9.61	11.53	
	P	60				4.08	4.05	4.03	4.07
		55	3.52	3.60	3.63	3.63	3.62	3.63	3.69
		50	3.04	3.15	3.21	3.23	3.24	3.26	3.34
		45	2.63	2.77	2.84	2.87	2.90	2.94	3.01
		40	2.29	2.44	2.53	2.57	2.60	2.64	2.72
		35	2.01	2.17	2.26	2.31	2.34	2.38	2.45
30		1.79	1.95	2.04	2.08	2.11	2.13	2.19	
25	1.62	1.78	1.86	1.89	1.90	1.91	1.95		
ZSI14KQE	Q	60				4.81	5.79	6.95	8.28
		55	2.89	3.58	4.40	5.36	6.49	7.80	9.31
		50	3.15	3.93	4.86	5.94	7.21	8.67	10.35
		45	3.43	4.30	5.32	6.52	7.92	9.52	11.36
		40	3.72	4.66	5.78	7.09	8.61	10.35	12.34
		35	4.00	5.01	6.21	7.62	9.26	11.14	13.28
		30	4.25	5.33	6.61	8.11	9.86	11.86	14.14
	25	4.45	5.59	6.94	8.53	10.38	12.50	14.92	
	P	60				4.88	4.96	5.03	5.09
		55	4.03	4.14	4.24	4.34	4.43	4.51	4.58
		50	3.56	3.68	3.80	3.91	4.01	4.10	4.17
		45	3.18	3.32	3.45	3.56	3.67	3.76	3.83
		40	2.87	3.02	3.15	3.27	3.37	3.46	3.52
		35	2.59	2.74	2.88	3.00	3.10	3.18	3.23
30		2.32	2.47	2.60	2.72	2.81	2.88	2.92	
25	2.02	2.16	2.29	2.40	2.48	2.53	2.56		

Notes:

1. Q for capacity; P for power. Units in kW
2. All ZSI values are rated at return gas temperature: 20°C and subcooling: 0 K

Performance table

TFM: 380 - 420 V ; 3-Phase, 50Hz

R404A

Model		Cond. temp. °C	Evap. temp. °C						
			-30	-25	-20	-15	-10	-5	0
ZSI06KQE	Q	60				2.08	2.54	3.08	3.69
		55	1.18	1.51	1.90	2.35	2.88	3.48	4.17
		50	1.35	1.70	2.12	2.62	3.21	3.88	4.65
		45	1.51	1.89	2.34	2.89	3.53	4.28	5.13
		40	1.66	2.06	2.55	3.15	3.85	4.66	5.60
		35	1.80	2.22	2.75	3.39	4.14	5.03	6.04
		30	1.91	2.36	2.92	3.60	4.42	5.37	6.47
	25	2.00	2.47	3.06	3.79	4.67	5.69	6.87	
	P	60				2.49	2.50	2.50	2.48
		55	2.05	2.10	2.14	2.17	2.19	2.19	2.18
		50	1.82	1.88	1.93	1.96	1.98	1.99	1.98
		45	1.66	1.73	1.79	1.83	1.85	1.86	1.84
		40	1.54	1.62	1.68	1.72	1.75	1.75	1.74
		35	1.42	1.50	1.57	1.61	1.63	1.63	1.62
30		1.26	1.35	1.41	1.45	1.47	1.46	1.44	
25	1.02	1.10	1.16	1.20	1.21	1.20	1.17		
ZSI08KQE	Q	60				2.63	3.16	3.78	4.49
		55	1.58	1.93	2.36	2.88	3.49	4.20	5.00
		50	1.72	2.12	2.61	3.20	3.88	4.66	5.55
		45	1.91	2.35	2.90	3.54	4.30	5.16	6.13
		40	2.10	2.59	3.18	3.89	4.70	5.64	6.69
		35	2.27	2.80	3.44	4.20	5.08	6.08	7.21
		30	2.39	2.95	3.64	4.45	5.38	6.45	7.66
	25	2.42	3.02	3.74	4.60	5.59	6.73	8.00	
	P	60				2.73	2.74	2.77	2.82
		55	2.35	2.39	2.42	2.44	2.46	2.50	2.55
		50	2.07	2.14	2.17	2.20	2.23	2.27	2.32
		45	1.85	1.92	1.97	2.00	2.03	2.07	2.13
		40	1.67	1.75	1.80	1.83	1.86	1.90	1.95
		35	1.51	1.60	1.65	1.68	1.71	1.74	1.78
30		1.38	1.46	1.51	1.54	1.56	1.57	1.60	
25	1.25	1.33	1.37	1.39	1.40	1.40	1.42		
ZSI09KQE	Q	60				2.93	3.52	4.20	4.99
		55	1.61	2.09	2.61	3.20	3.86	4.63	5.52
		50	1.82	2.34	2.91	3.56	4.30	5.15	6.14
		45	2.08	2.64	3.26	3.97	4.78	5.72	6.80
		40	2.35	2.95	3.62	4.39	5.27	6.30	7.47
		35	2.59	3.22	3.94	4.77	5.73	6.83	8.10
		30	2.75	3.42	4.19	5.08	6.11	7.29	8.65
	25	2.80	3.50	4.32	5.26	6.36	7.62	9.08	
	P	60				3.14	3.13	3.14	3.19
		55	2.71	2.77	2.79	2.80	2.81	2.83	2.89
		50	2.39	2.46	2.50	2.51	2.53	2.56	2.63
		45	2.12	2.20	2.25	2.27	2.29	2.33	2.40
		40	1.89	1.98	2.03	2.06	2.09	2.13	2.19
		35	1.70	1.80	1.85	1.88	1.90	1.94	2.00
30		1.54	1.63	1.69	1.71	1.73	1.76	1.82	
25	1.40	1.49	1.53	1.55	1.56	1.58	1.63		
ZSI11KQE	Q	60				3.75	4.48	5.36	6.44
		55	2.25	2.86	3.50	4.21	5.04	6.04	7.25
		50	2.45	3.12	3.83	4.63	5.56	6.68	8.01
		45	2.63	3.36	4.14	5.03	6.05	7.27	8.73
		40	2.80	3.59	4.44	5.40	6.52	7.85	9.42
		35	2.98	3.82	4.73	5.77	6.98	8.41	10.10
		30	3.18	4.06	5.04	6.15	7.44	8.97	10.77
	25	3.41	4.33	5.36	6.54	7.92	9.53	11.44	
	P	60				3.78	3.75	3.74	3.77
		55	3.26	3.34	3.37	3.36	3.35	3.37	3.42
		50	2.82	2.92	2.97	2.99	3.00	3.03	3.09
		45	2.44	2.57	2.63	2.67	2.69	2.72	2.80
		40	2.12	2.26	2.34	2.38	2.41	2.45	2.52
		35	1.86	2.01	2.10	2.14	2.17	2.20	2.27
30		1.66	1.81	1.89	1.93	1.95	1.98	2.03	
25	1.51	1.65	1.73	1.76	1.76	1.77	1.81		

Notes:

1. Q for capacity; P for power. Units in kW
2. All ZSI values are rated at return gas temperature: 20°C and subcooling: 0 K

Performance table

TFM: 380 - 420 V ; 3-Phase, 50Hz

R404A

Model		Cond. temp. °C	Evap. temp. °C						
			-30	-25	-20	-15	-10	-5	0
ZSI14KQE	Q	60				4.72	5.69	6.82	8.14
		55	2.83	3.52	4.32	5.27	6.38	7.66	9.15
		50	3.09	3.86	4.77	5.84	7.08	8.51	10.16
		45	3.37	4.22	5.23	6.41	7.78	9.36	11.16
		40	3.66	4.58	5.68	6.96	8.45	10.17	12.13
		35	3.93	4.92	6.10	7.49	9.09	10.94	13.04
		30	4.18	5.23	6.49	7.97	9.68	11.65	13.89
	25	4.37	5.49	6.81	8.38	10.19	12.28	14.65	
	P	60				4.60	4.67	4.74	4.80
		55	3.80	3.90	4.00	4.09	4.18	4.25	4.32
		50	3.36	3.47	3.58	3.69	3.78	3.86	3.93
		45	3.00	3.13	3.25	3.36	3.46	3.54	3.60
		40	2.70	2.84	2.97	3.08	3.18	3.26	3.32
		35	2.44	2.58	2.71	2.82	2.92	2.99	3.05
30		2.18	2.33	2.45	2.56	2.65	2.71	2.75	
ZSI15KQE	Q	60				5.32	6.33	7.53	9.00
		55	3.26	4.15	5.07	6.07	7.23	8.61	10.28
		50	3.57	4.54	5.56	6.69	7.99	9.55	11.41
		45	3.81	4.86	5.97	7.21	8.66	10.38	12.44
		40	4.03	5.14	6.34	7.70	9.28	11.16	13.41
		35	4.28	5.44	6.72	8.19	9.91	11.95	14.37
		30	4.60	5.82	7.18	8.75	10.59	12.78	15.38
	25	5.04	6.31	7.75	9.41	11.38	13.72	16.49	
	P	60				5.28	5.41	5.46	5.41
		55	4.13	4.30	4.47	4.64	4.77	4.84	4.82
		50	3.68	3.82	3.98	4.14	4.28	4.37	4.37
		45	3.33	3.44	3.59	3.75	3.89	3.99	4.03
		40	3.03	3.12	3.25	3.40	3.55	3.67	3.73
		35	2.74	2.80	2.91	3.06	3.22	3.35	3.45
30		2.40	2.44	2.54	2.68	2.84	3.00	3.12	
25	1.98	1.99	2.07	2.21	2.38	2.55	2.70		
ZSI18KQE	Q	60				6.52	7.81	9.32	11.06
		55	4.01	4.95	6.04	7.31	8.77	10.47	12.42
		50	4.41	5.46	6.67	8.07	9.70	11.59	13.76
		45	4.81	5.95	7.27	8.82	10.61	12.67	15.05
		40	5.18	6.41	7.85	9.53	11.47	13.72	16.30
		35	5.54	6.85	8.39	10.20	12.30	14.72	17.49
		30	5.86	7.25	8.89	10.82	13.07	15.66	18.62
	25	6.14	7.60	9.34	11.39	13.78	16.54	19.68	
	P	60				6.31	6.44	6.54	6.58
		55	5.21	5.29	5.42	5.57	5.72	5.84	5.90
		50	4.61	4.71	4.86	5.03	5.19	5.32	5.40
		45	4.17	4.28	4.44	4.62	4.80	4.94	5.02
		40	3.82	3.94	4.11	4.29	4.47	4.61	4.70
		35	3.50	3.62	3.79	3.98	4.16	4.30	4.38
30		3.14	3.27	3.44	3.62	3.80	3.93	4.00	
25	2.71	2.83	2.99	3.16	3.32	3.45	3.50		
ZSI21KQE	Q	60				7.35	8.81	10.49	12.39
		55	4.50	5.54	6.77	8.20	9.85	11.74	13.88
		50	4.94	6.09	7.45	9.04	10.87	12.96	15.33
		45	5.38	6.62	8.11	9.84	11.85	14.15	16.74
		40	5.79	7.13	8.73	10.62	12.79	15.29	18.11
		35	6.18	7.60	9.32	11.34	13.69	16.37	19.41
		30	6.52	8.03	9.86	12.02	14.53	17.40	20.65
	25	6.82	8.41	10.35	12.64	15.30	18.35	21.81	
	P	60				6.79	6.91	7.05	7.20
		55	5.71	5.82	5.94	6.08	6.23	6.39	6.56
		50	5.09	5.22	5.37	5.52	5.69	5.87	6.05
		45	4.59	4.74	4.90	5.08	5.26	5.44	5.63
		40	4.18	4.35	4.52	4.70	4.89	5.08	5.27
		35	3.83	3.99	4.17	4.35	4.54	4.73	4.92
30		3.47	3.64	3.81	3.99	4.17	4.35	4.53	
25	3.08	3.24	3.41	3.58	3.74	3.91	4.08		

Notes:

1. Q for capacity; P for power. Units in kW
2. All ZSI values are rated at return gas temperature: 20°C and subcooling: 0 K

Technical data

Compressor model			Liquid injection															
			ZSI06KQ/E		ZSI08KQ/E		ZSI09KQ/E		ZSI11KQ/E		ZSI14KQ/E		ZSI15KQ/E		ZSI18KQ/E		ZSI21KQ/E	
Nominal horsepower		HP	2		2.5		3		3.5		4		5		6		7.5	
Displacement	50Hz	m ³ /hr	6.1		7		8		9.9		12.7		14.4		17.1		18.8	
Motor type		50Hz	TFM		TFM		TFM		TFM		TFM		TFM		TFM		TFM	
			PFZ		PFZ		-		-		-		-		-		-	
Refrigerant			R22	R404A	R22	R404A	R22	R404A	R22	R404A	R22	R404A	R22	R404A	R22	R404A	R22	R404A
Locked rotor current (LRA)	50Hz	TFM	39.2		39.2		39.2		51.5		51.5		51.5		74.0		101.0	
		PFZ	56.6		71.5		-		-		-		-		-		-	
Maximum operating current (MOC)	50Hz	TFM	5.2	5.7	5.6	6.1	6.2	6.7	6.6	7.5	8.2	9.2	10.1	11.9	11.2	13.7	13.6	14.6
		PFZ	11.5	13.6	13.1	15.6	-	-	-	-	-	-	-	-	-	-	-	-
Maximum continuous current (MCC)	50Hz	TFM	6.8	7.9	6.7	7.9	7.0	7.8	10.0	11.2	10.9	12.1	11.8	12.7	13.3	15.0	16.2	19.3
		PFZ	14.4	17.2	15.7	18.0	-	-	-	-	-	-	-	-	-	-	-	-
Rated load current (RLA=MCC/1.4)	50Hz	TFM	4.9	5.6	4.8	5.6	5.0	5.6	7.1	8.0	7.8	8.6	8.4	9.1	9.5	10.7	11.6	13.8
		PFZ	10.3	12.3	11.2	12.9	-	-	-	-	-	-	-	-	-	-	-	-
Rated load current (RLA=MCC/1.56)	50Hz	TFM	4.4	5.1	4.3	5.1	4.5	5.0	6.4	7.2	7.0	7.8	7.6	8.1	8.5	9.6	10.4	12.4
		PFZ	9.2	11.0	10.1	11.5	-	-	-	-	-	-	-	-	-	-	-	-
Winding resistance at 25 °C		TFM	6.45		6.45		6.45		3.20		3.20		3.20		2.26		1.79	
		PFZ	1.4/1.57		1.22/1.36		-		-		-		-		-		-	
Connection size			Brazing connection															
			Suction	3/4				7/8				7/8						
			Discharge	1/2				1/2				1/2						
Outline dimension			Injection	3/8				3/8				3/8						
			Length	243				242				251						
			Width	243				242				246						
Oil quantity			Height	388				431				438						
			L	0.74				1.36				1.89						
Net weight		kg	22.2				29.9				39.5		39.7					
Terminal box IP grade			IP21				IP21				IP21							
Crankcase heater power		W	33				40				40							
Mounting parts Installation size (hole size)		mm	190x 190 (Ø19)				190x 190 (Ø19)				190x 190 (Ø19)							

Application guide

Liquid injection for discharge temperature protection

An Injection EXV must be applied when using the ZSI scrolls for liquid injection operation. This valve is approved for all refrigerants in this product range.

A sensor on the discharge line is used to determine the degree of opening of the Injection EXV, thus ensuring proper injection flow rate.

Liquid injection technology for efficient operation

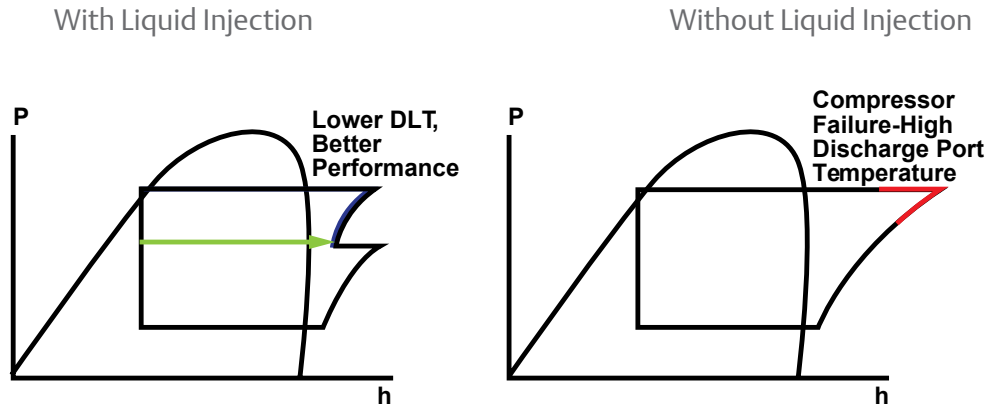

Extremely enhanced reliability compared to non-injection scroll compressors at LT application

System configuration

ZSI compressor requires a liquid injection circuit from the system's liquid line to the compressor's injection fitting. Note that ensuring the injection circuit can pick up enough liquid is important for this function.

A sight glass can be installed before the injection circuit's EXV to allow visual inspection of the presence of liquid refrigerant.

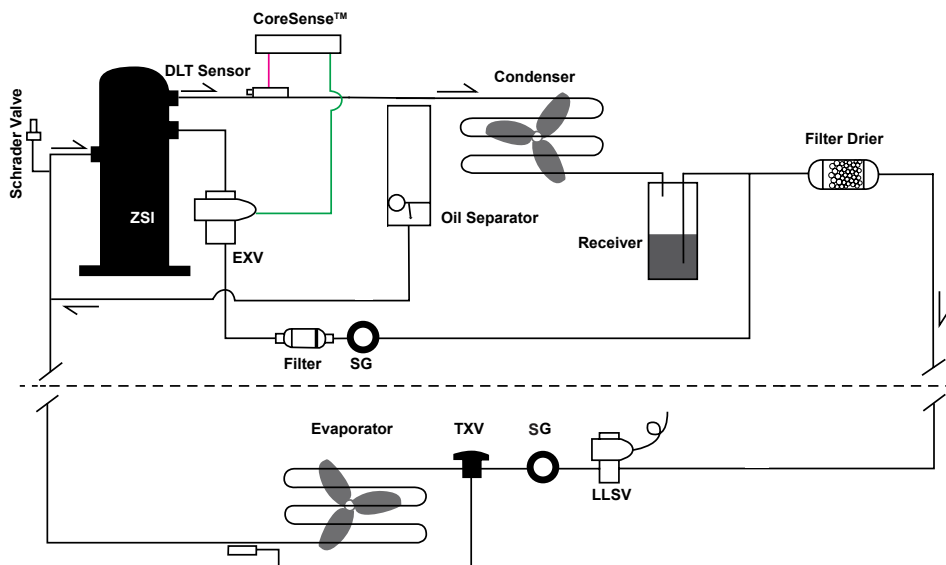

Liquid Injection controlled by CoreSense Module

DLT Sensor signals EXV to control the flow depending on Discharge Line Temperature (DLT)

CoreSense features and functions

CoreSense is supplied as a standard together with the compressor. This controls the amount of liquid injection by measuring the discharge temperature through an electronic sensor mounted on the discharge line. With the CoreSense built-in program, it automatically calculates the EXV's opening and commands it to inject the optimized amount of liquid refrigerant into the compressor.

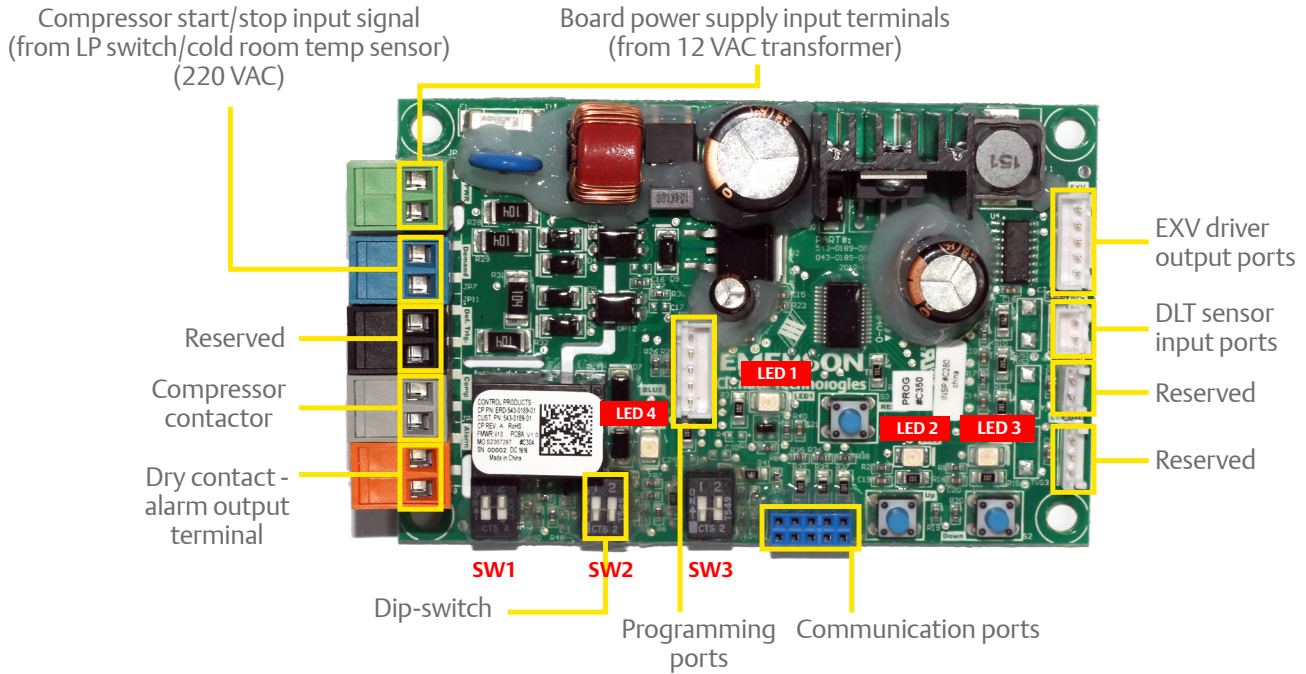

LED display	Description
1 (Yellow Green)	LED blinking pattern indicates DLT Sensor status
2 (Yellow Green)	LED 2 & LED 3 combination and blinking patterns indicate EXV opening or closing
3 (Yellow Green)	LED 2 & LED 3 blink once when entering or exiting EXV manual operation
4 (Red)	LED 4 turns on as an alarm when triggered by any of the following: 1) DLT overheat protection 2) DLT sensor open circuit 3) DLT sensor short circuit 4) DLT sensor under detection range 5) DLT sensor over detection range 6) DLT sensor failure at 130°C or above

LED display alerts user of DLT sensor status and EXV operation enabling easier troubleshooting

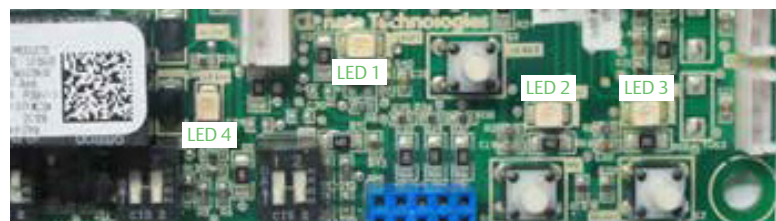

ZSI standard control box wiring

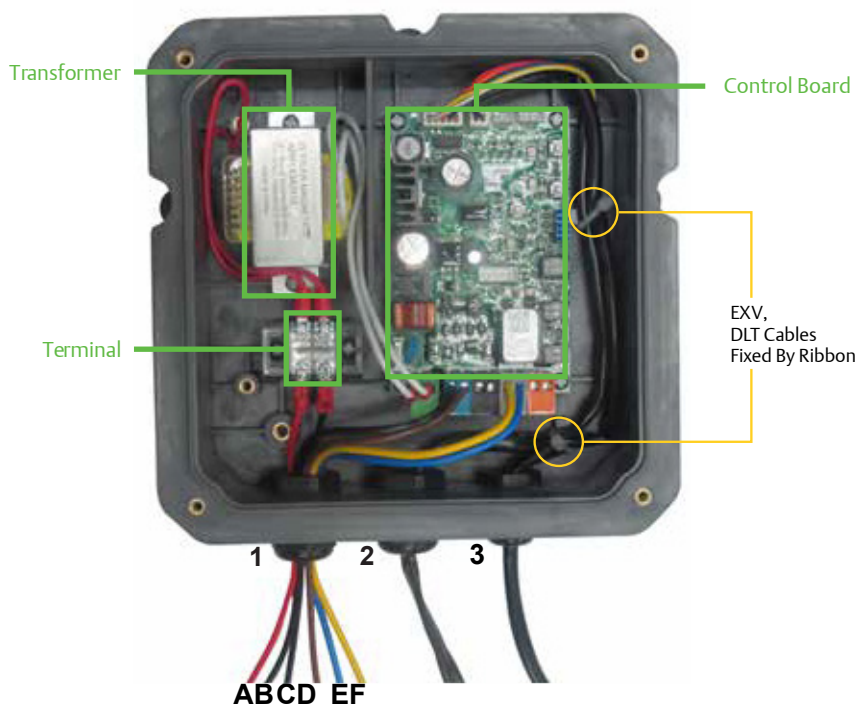

Waterproof gland No.	Gland 1	Gland 2	Gland 3
Wire function	<p>A (Red) and B (Black): Controller power supply input (220–240 VAC 50/60 Hz)</p> <p>C (Black) and D (Brown): Compressor start/stop input (220–240 VAC 50/60 Hz)</p> <p>E (Blue) and F (Yellow): Compressors contactor coil Control output</p>	EXV Coil	DLT Sensor
Wire connection	<p>Wires A and B: Connect to terminal</p> <p>Wires C and D: Connect to the blue connector on the control board</p> <p>Wires E and F: Connect to the gray connector on the control board</p>	Connect to the EXV port at the top edge of the control board	Connect to the DLT port at the top edge of the control board
Gland internal diameter range	2–3 mm		
Jacket line requirement	<p>Internal wire size: 18 AWG</p> <p>4 Rated voltage: 300 V/600 V</p> <p>Rated temperature: 80/105 °C</p> <p>Recommended: UL105, UL1011, UL1007</p>		

Accumulator requirements

Due to the Copeland Scroll™ compressor's inherent ability to handle liquid refrigerant in flooded start and defrost operation conditions, accumulators may not be required. An accumulator is required on single compressor systems when the system charge exceeds the charge limitations listed in Table 1. In systems with defrost schemes or transient operations that allow prolonged, uncontrolled liquid return to the compressor, an accumulator is required unless a suction header of sufficient volume is used to prevent liquid migration to the compressor.

Note: When using an accumulator, please ensure that the filter on the oil return hole is with screen < 30 mesh

Table 1. Charge limitation

Model family	Charge limitation
ZSI06-15	4.09 kg
ZSI18-21	4.54 kg

Superheat requirements

In order to assure that liquid refrigerant does not return to the compressor during the running cycle, attention must be given to maintaining proper superheat at the compressor suction inlet. Emerson recommends a minimum of 11 K superheat, measured on the suction line 6 inches (152 mm) from the suction valve, to prevent liquid refrigerant floodback.

Another method to determine if liquid refrigerant is returning to the compressor is to accurately measure the temperature difference between the compressor oil crankcase and the suction line. During continuous operation we recommend that this difference be a minimum of 50°F (27°C). This “crankcase differential temperature” requirement supersedes the minimum suction superheat requirement in the last paragraph. To measure oil temperature through the compressor shell, place a thermocouple on the bottom center (not the side) of the compressor shell and insulate from the ambient.

During rapid system changes, such as defrost or ice harvest cycles, this temperature difference may drop rapidly for a short period of time. When the crankcase temperature difference falls below the recommended 50°F (27°C), we recommend that duration should not exceed a maximum (continuous) time period of two minutes and should not go lower than a 25°F (14°C) difference.

Under all application conditions, the return gas temperature should be less than 18°C, and the injection sub-cooling should be more than 1 K.

Contact your Emerson Climate Technologies representative regarding any exceptions to the above requirements.

Crankcase heater

Crankcase heaters are required on outdoor systems when the system charge exceeds the charge limitations listed in Table 2.

Table 2 includes the cross reference of crankcase heaters and compressor models. If the customer purchases crankcase heater from other suppliers, its power rating should not go below the listed values in Table 2.

Table 2. Crankcase heater

Crankcase heater power	ZSI06KQ	ZSI08KQ	ZSI09KQ	ZSI11KQ	ZSI14KQ	ZSI15KQ	ZSI18KQ	ZSI21KQ
33 W	✓	✓	✓	✓				
40 W					✓	✓	✓	✓

Pressure controls

Both high and low pressure controls are required. The minimum and maximum pressure setpoints are shown in Table 3.

Table 3. Pressure controls

Model	Control type	R404A	R22
All ZSI	Suction Pressure	>1.02 bar(g)	>0.64 bar(g)
	Discharge Pressure	<28 bar(g)	<23 bar(g)

IPR valve

ZSI compressors have Internal Pressure Relief valves, which open at a discharge to suction differential pressure of 375 to 450 psi [25.86 to 31.03 bar(g)]. This action will trip the motor protector and remove the motor from the line.

Motor protection

Motor protection in the ZSI compressor for refrigeration is by Internal Line Break (ILB). An “F” in the second character of the motor code indicates an internal line break. For example, a ZSI09KQE-TFD has ILB.

Rack application

Currently, ZSI models are not yet approved for rack applications.

Discharge mufflers

Gas flow through scroll compressors is continuous with relatively low pulsation. External mufflers applied to piston compressors may not be required on Copeland Scroll™ compressors. Due to system variability, individual tests should be conducted by the system manufacturer to verify acceptable levels of sound and vibration.

Rotation direction of the three-phase scroll compressors

Scroll compressors will only compress in one rotational direction. Direction of rotation is not an issue with single-phase compressors since they will always start and run in the proper direction. Three-phase compressors will rotate in either direction depending upon phasing of the power. Since there is a 50-50 chance of connecting power in such a way as to cause rotation in the reverse direction, it is important to include notices and instructions in appropriate locations on the equipment to ensure proper rotation direction when the system is installed and operated. Verification of proper rotation direction is made by observing that suction pressure drops and discharge pressure rises when the compressor is energized. Reverse rotation of a scroll compressor also results in substantially reduced current draw compared to specification sheet values. Suction temperature will be high, discharge temperature will be low and the compressor may be abnormally noisy.

There is no negative impact on durability caused by operating three-phase Copeland Scroll compressors in the reversed direction for a short period of time (under one hour), but oil may be lost. Oil loss can be prevented during reverse rotation if the tubing is routed at least six inches (15 cm) above the compressor. After several minutes of operation in reverse, the compressor’s motor protection system will trip the compressor off. If allowed to repeatedly restart and run in reverse without correcting the situation, the compressor will be permanently damaged.

All three-phase scroll compressors are identically wired internally. As a result, once the correct phasing is determined for a specific system or installation, connecting properly phased power leads to the same terminals will maintain proper rotation direction.

Connection fittings

Only stub fittings are available for the ZSI model. Detailed information is given in Table 4.

Table 4. Connection Fittings

	Suction fitting	Discharge fitting	Injection fitting
ZSI06	3/4"	1/2"	3/8"
ZSI08	3/4"	1/2"	3/8"
ZSI09	3/4"	1/2"	3/8"
ZSI11	7/8"	1/2"	3/8"
ZSI14	7/8"	1/2"	1/2"
ZSI15	7/8"	1/2"	1/2"
ZSI18	7/8"	1/2"	1/2"
ZSI21	7/8"	1/2"	1/2"

Deep vacuum operation

WARNING: Do not run a Copeland Scroll compressor in a deep vacuum. Failure to heed this advice can result in arcing of the Fusite pins and permanent damage to the compressor.

A low pressure control is required for protection against deep vacuum operation. See Pressure Control section for proper setpoints (Table 3).

Scroll compressors (as with any refrigerant compressor) should never be used to evacuate a refrigeration or air conditioning system. See AE-1105 for proper system evacuation procedures.

High potential (hipot) testing

A hipot test is usually conducted on the production line by the manufacturer. This test can be conducted in the field, however, field technicians typically do not have the required equipment.

Copeland Scroll compressors are configured with the motor down and the pumping components at the top of the shell. As a result, the motor can be immersed in oil and refrigerant to a greater extent than hermetic reciprocating compressors when liquid refrigerant is present in the shell. In this respect, the scroll is more like semi-hermetic compressors which can have horizontal motors partially submerged in oil and refrigerant. When Copeland Scroll compressors are Hipot tested with liquid refrigerant in the shell, they can show higher levels of leakage current than compressors with the motor on top. This phenomenon can occur with any compressor when the motor is immersed in refrigerant. The level of current leakage does not present any safety issue. To lower the current leakage reading, the system should be operated for a brief period of time to redistribute the refrigerant to a more normal configuration and the system Hipot tested again. See AE Bulletin 4-1294 for Megohm testing recommendations. Under no circumstances should the Hipot test be performed while the compressor is under a vacuum.

Scroll compressor functional check

A functional compressor test, with the suction service valve closed to check how low the compressor will pull suction pressure, not a good indication of how well a compressor is performing. Such a test will almost certainly damage a scroll compressor. The following diagnostic procedure should be used to evaluate whether a Copeland Scroll™ compressor is working properly.

1. Proper voltage to the unit should be verified.
2. The normal checks of motor winding continuity and short to ground should be made to determine if the inherent overload motor protector has opened or if an internal motor short or ground fault has developed. If the protector has opened, the compressor must be allowed to cool sufficiently to allow it to reset.
3. Proper indoor and outdoor blower/fan operation should be verified.
4. With service gauges connected to suction and discharge pressure fittings, turn on the compressor. If suction pressure falls below normal levels, the system is either low on charge or there is a flow blockage in the system.
5. If suction pressure does not drop and discharge pressure does not rise to normal levels, reverse any two of the compressor power leads and reapply power to make sure compressor was not wired to run in reverse direction.
6. To test if the compressor is pumping properly, the compressor current draw must be compared to published compressor performance curves using the operating pressures and voltage of the system. If the measured average current deviates more than $\pm 15\%$ from published values, a faulty compressor may be indicated. A current imbalance exceeding 15% of the average on the Three-Phases should be investigated further. A more comprehensive troubleshooting sequence for compressors and systems can be found in Section H of the Copeland™ brand products Electrical Handbook.
7. Before replacing or returning a compressor: be certain that the compressor is actually defective. To be sure, recheck a compressor returned from the field in the shop or depot for Hipot, winding resistance, and ability to start before returning. More than one-third of compressors returned to Emerson for warranty analysis are determined to have no glitches. The units were misdiagnosed in the field as being defective. Replacing working compressors unnecessarily costs everyone.
8. NEVER test a scroll compressor by closing the suction valve or the liquid feed to the evaporator and pumping the compressor into a vacuum.

New installation

1. The copper-coated steel suction, discharge and injection tubes on scroll compressors can be brazed in approximately the same manner as any copper tube.
2. Recommended brazing material – any brazing material with a minimum silver content of 5% is preferred. However, 0% silver is acceptable.
3. Use of a dry nitrogen purge to eliminate possibility of carbon buildup on internal tube surfaces is recommended.
4. Be sure process tube fitting I.D. and process tube O.D. are clean prior to assembly.
5. Apply heat in Area 1. As tube approaches brazing temperature, move torch flame to Area 2 (See Figure 1).
6. Heat Area 2 until braze temperature is attained, moving torch up and down and rotating around tube as necessary to heat tube evenly. Add braze material to the joint while moving torch around circumference.
7. After braze material flows around joint, move torch to heat Area 3. This will draw the braze material down into the joint. The time spent heating Area 3 should be minimal.
8. As with any brazed joint, overheating may be detrimental to the final result.

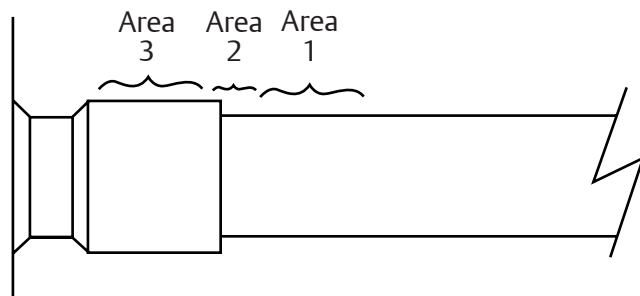

Figure 1. Scroll tube brazing

Field service

1. To disconnect: recover refrigerant from both high and low sides of the system. Cut tubing near compressor.
2. To reconnect: recommended brazing materials – any material with a minimum of 5% silver or silver braze material with flux.
3. Reinsert tubing fitting.
4. Heat tube uniformly in Area 1, moving slowly to Area 2. When joint reaches brazing temperature apply brazing material (See Figure 1).
5. Heat joint uniformly around the circumference to flow braze material completely around the joint.
6. Slowly move torch in Area 3 to draw braze material into the joint.

Do not overheat joints.

WARNING

If the refrigerant charge is removed from a scroll unit by bleeding the high side only, it is sometimes possible for the scrolls to seal, preventing pressure equalization through the compressor. This may leave the low side shell and suction line tubing pressurized. If a brazing torch is then applied to the low side, the pressurized refrigerant and oil mixture could ignite as it escapes and contacts the brazing flame. It is important to check both the high and low sides with manifold gauges before unbrazing or in the case of assembly line repair, remove refrigerant from both the high and low sides. Instructions should be provided in appropriate product literature and assembly (line repair) areas.

Compressor replacement after motor burn

In the case of a motor burn, the majority of contaminated oil will be removed with the compressor. The rest of the oil is cleaned through use of suction and liquid line filter driers. A 100% activated alumina suction filter drier is recommended but must be removed after 72 hours. See AE Bulletin 24-1105 for clean up procedures and AE Bulletin 11-1297 for liquid line filter drier recommendations. It is highly recommended that the suction accumulator be replaced if the system contains one. This is because the accumulator oil return orifice or screen may be plugged with debris or may become plugged shortly after a compressor failure. This will result in starvation of oil to the replacement compressor and a second failure.

System charging procedure

Systems should be charged with liquid on the high side to the maximum possible extent. This will avoid running the compressor under conditions where there is insufficient gas. Sufficient suction gas is available to cool not only the motor but also the scrolls.

The majority of the charge should be pumped into the high side of the system to prevent hipot failures, and bearing washout during first time start. If additional charge is needed, it should be added as liquid, in a controlled manner, to the low side of the system with the compressor operating. Pre-charging on the high side and adding liquid on the low side of the system are both meant to protect the compressor from operating with abnormally low suction pressures during charging.

NOTICE: Do not use compressor to test opening setpoint of high pressure cutout. Bearings are susceptible to high load damage before they have had several hours of normal running for proper break-in.

Dimensional drawings

ZSI06 to ZSI09 (BOM 527)

Stub tube connection

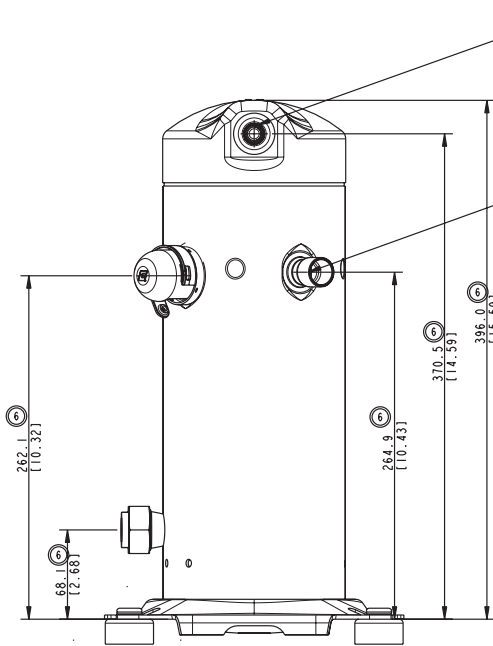
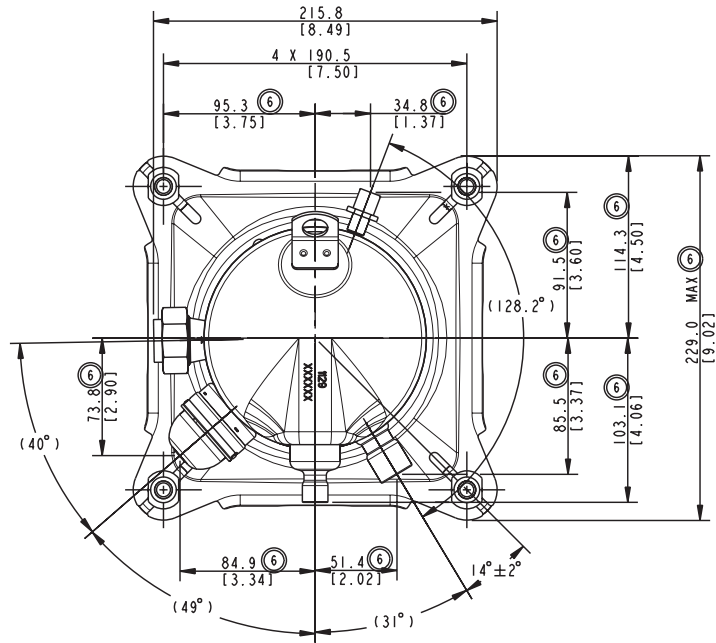

∅ 12.78-12.95 I.D.
 [0.5032-0.5098]
 ∇ 10.10 [0.398] MIN, 0.038 [0.0015] MIN THICK EXTERIOR AND 0.038 [0.0015] MIN THICK INTERIOR COPPER PLATED STEEL DISCHARGE FITTING.

∅ 19.12-19.30 I.D.
 [0.7528-0.7598]
 ∇ 16.00 [0.630] MIN, 0.038 [0.0015] MIN THICK EXTERIOR AND 0.038 [0.0015] MIN THICK INTERIOR COPPER PLATED STEEL SUCTION FITTING

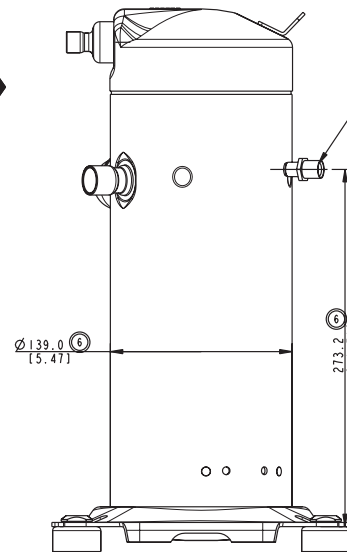

∅ 9.70-9.80 I.D.
 [0.3819-0.3858]
 ∇ 9.0 [0.3543] 0.02 [0.00079] MIN THICK EXTERIOR AND 0.02 [0.00079] MIN THICK INTERIOR COPPER PLATED STEEL LIQUID INJECTION FITTING

SEE DETAIL Y

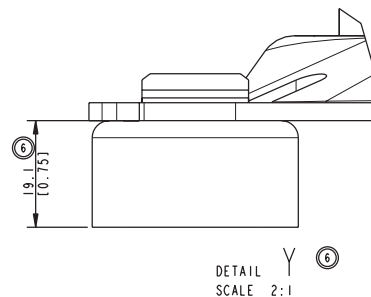
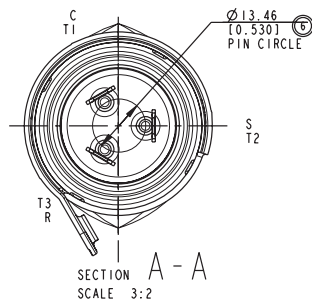

Notes:

1. All tolerances ± 1.5mm [0.06in] unless otherwise specified
2. Due to accumulated assembly tolerances, the listed components may vary from the mounting holes. All fittings: ± 3.0mm [0.12in]
3. Tube ends must be plugged
4. All units are in mm [inch]

Dimensional drawings

ZSI11 to ZSI15 (BOM 527)

Stub tube connection

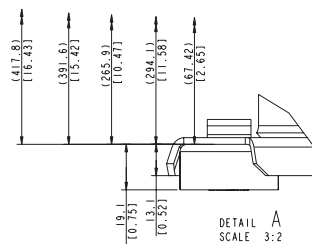
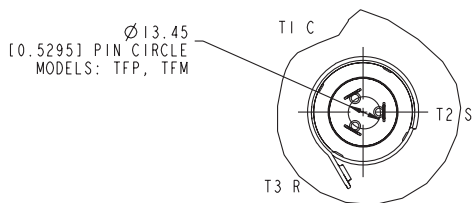
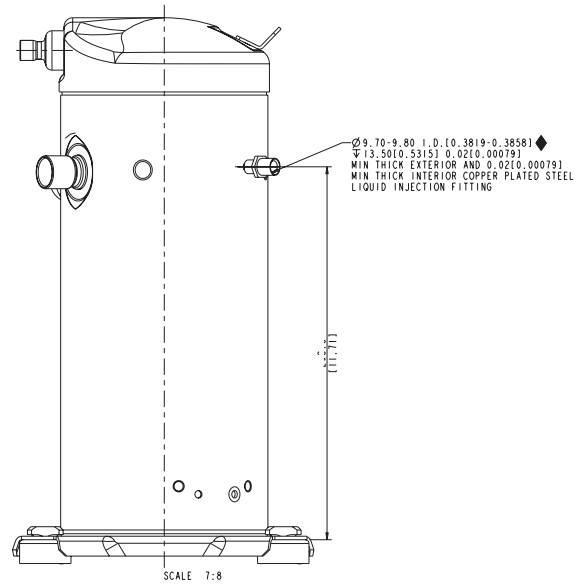
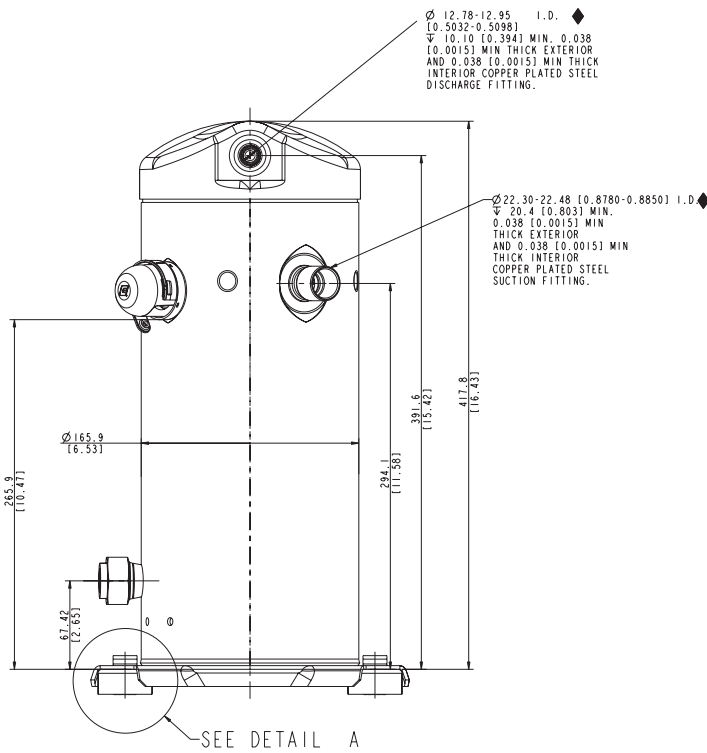
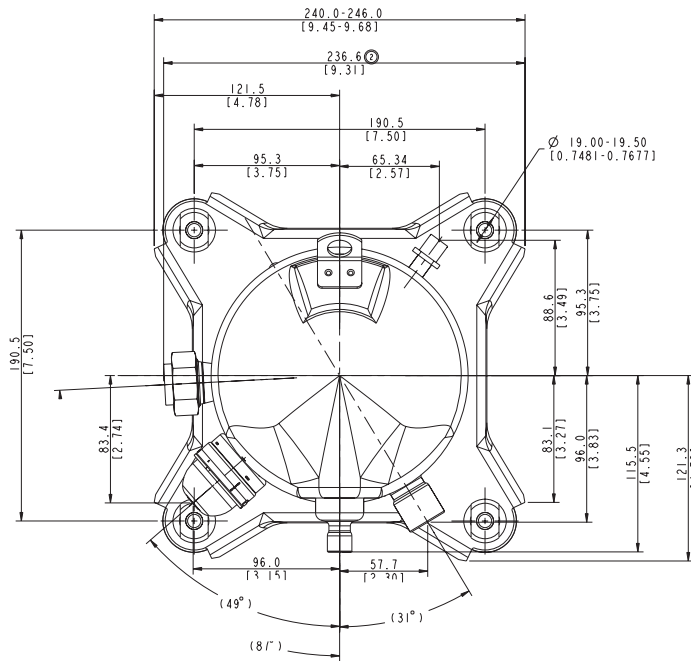

Notes:

1. All tolerances ± 1.5mm [0.06in] unless otherwise specified
2. Due to accumulated assembly tolerances, the listed components may vary from the mounting holes. All fittings: ± 3.0mm [0.12in]
3. Tube ends must be plugged
4. All units are in mm [inch]

Dimensional drawings

ZSI18 to ZSI21 (BOM 537)

Stub tube connection

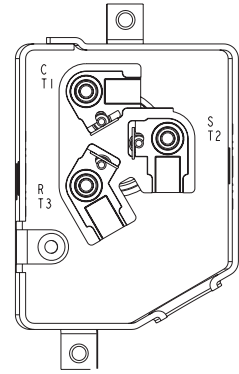
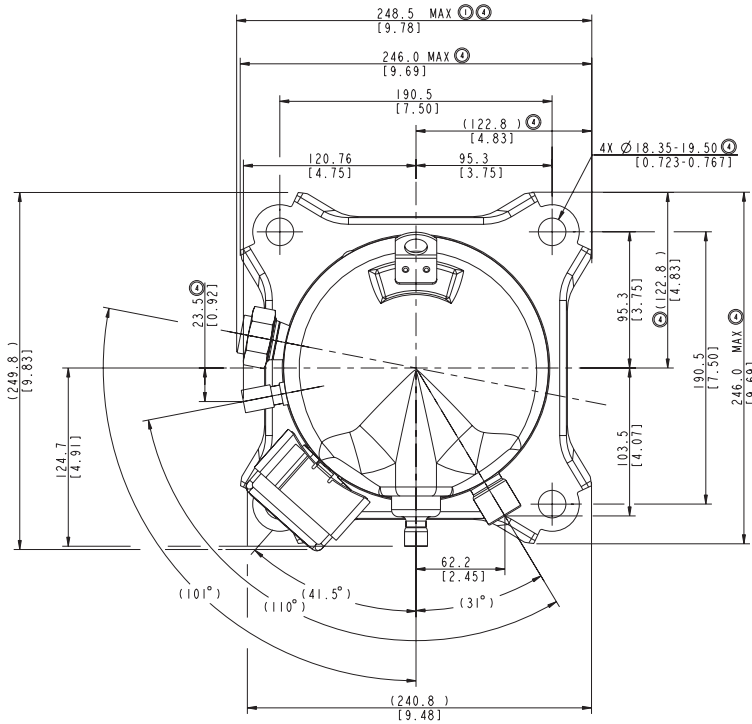

T-BOX LAYOUT
OPTIONAL
SCALE 3:2

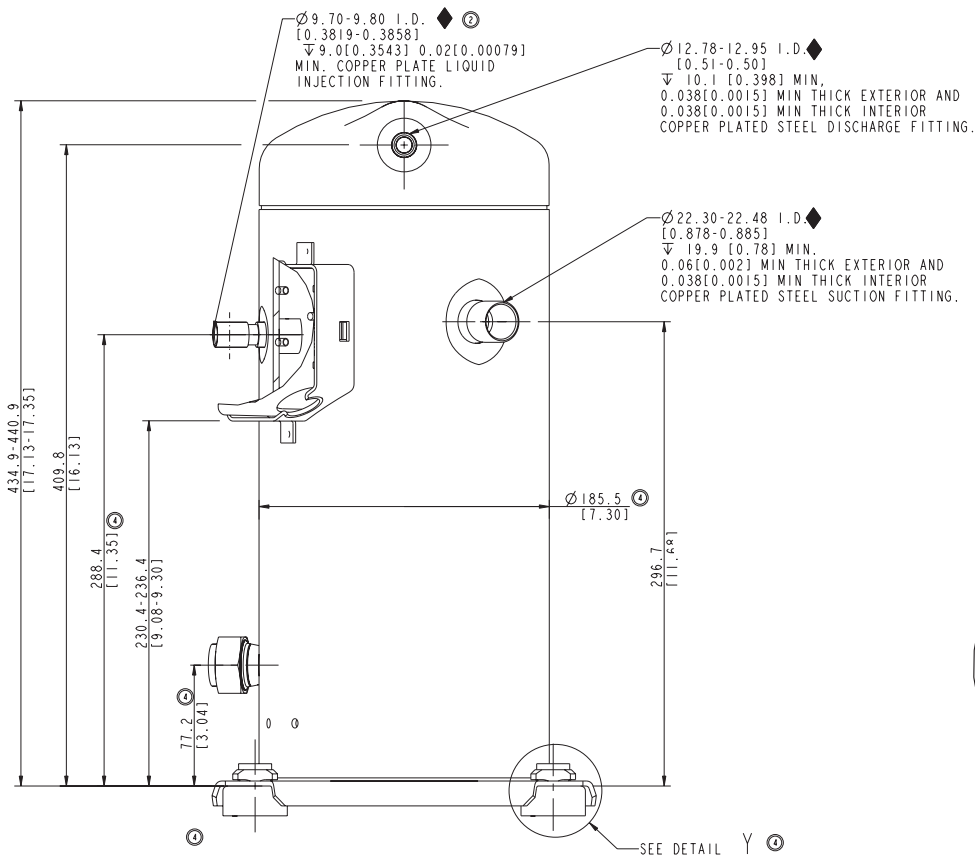

Ø 17.45 PIN CIRCLE
[Ø 0.687]
MODELS: TFP,TFM

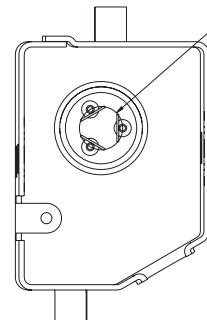

T-BOX LAYOUT
STANDARD
SCALE 3:2

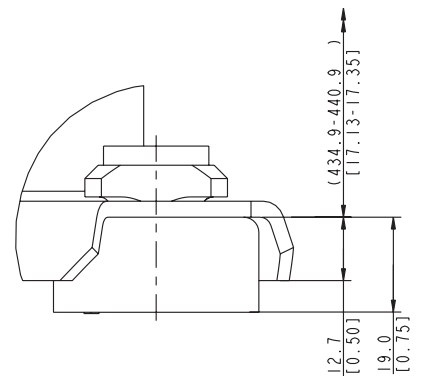

DETAIL Y
SCALE 2:1

Notes:

1. All tolerances $\pm 1.5\text{mm}$ [0.06in] unless otherwise specified
2. Due to accumulated assembly tolerances, the listed components may vary from the mounting holes. All fittings: $\pm 3.0\text{mm}$ [0.12in]
3. Tube ends must be plugged
4. All units are in mm [inch]

Wiring diagram

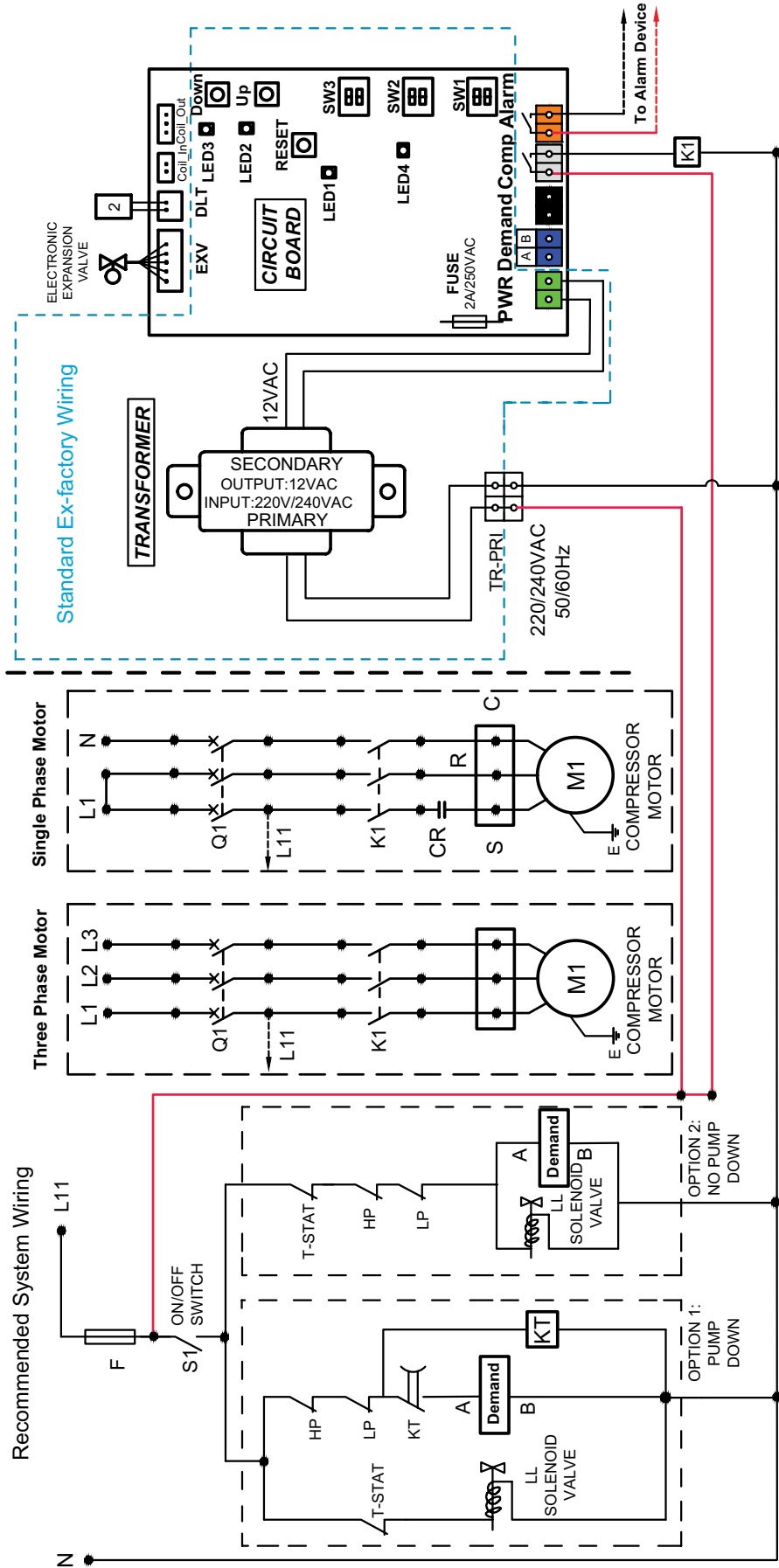

- K1 - COMPRESSOR CONTACTOR
- Q1 - CIRCUIT BREAKER
- KT - TIME DELAY RELAY
- DEMAND - COMPRESSOR ON/OFF SIGNAL
- CR - RUN CAPACITOR
- 2 - DISCHARGE LINE TEMP. SENSOR

Contact list

Asia Pacific Headquarters

Emerson Climate Technologies
Suite No. 2503-8, 25/F,
Exchange Tower, 33 Wang Chiu Road,
Kowloon Bay, Kowloon, Hong Kong
Tel: (852) 2866 3108
Fax: (852) 2520 6227

Australia

Emerson Climate Technologies Australia
Pty Ltd
356 Chisholm Road
Auburn NSW 2144, Australia
Tel: (612) 9795 2800
Fax: (612) 9738 1699

China - Beijing

Emerson Climate Technologies
(Suzhou) Co. Ltd
Beijing Sales Office
Room 1017 JianWei Building,
66 Nan Lishi Road, XiCheng District,
Beijing, PRC
Tel: (8610) 5763 0488
Fax: (8610) 5763 0499

China - Guangzhou

Emerson Climate Technologies
(Suzhou) Co. Ltd
Guangzhou Sales Office
508-509 R&F Yinglong Plaza,
No. 76 Huangpu Road West,
Guangzhou, PRC
Tel: (8620) 2886 7668
Fax: (8620) 2886 7622

China - Shanghai

Emerson Climate Technologies
(Suzhou) Co. Ltd
Shanghai Sales Office
7F, Emerson Building, 1582 Gumei
Rd, Shanghai, PRC
Tel: (8621) 3338 7333

India - Mumbai

Emerson Climate Technologies (India) Ltd
Delphi B-Wing, 601-602, 6th Floor
Central Avenue, Hiranandani Business Park,
Powai, Mumbai 400076
Tel: (9122) 6786 0793
Fax: (9122) 6662 0500

India - Pune

Emerson Climate Technologies (India) Ltd
Plot No. 23, Rajiv Gandhi Infotech Park,
Phase - II, Hinjewadi,
Pune 411 057, Maharashtra, India
Tel: (9120) 4200 2000
Fax: (9120) 4200 2099

Indonesia

PT Emerson Indonesia
BSD Taman Tekno 8
Jl. Tekno Widya Blok H10 No 2 & 3
Tangerang Selatan 15314
Indonesia
Tel: (6221) 2966 6242
Fax: (6221) 2966 6245

Japan

Emerson Japan Ltd
Shin-yokohama Tosho Building
No. 3-9-5 Shin-Yokohama, Kohoku-ku
Yokohama 222-0033 Japan
Tel: (8145) 475 6371
Fax: (8145) 475 3565

Malaysia

Emerson Electric (Malaysia) Sdn. Bhd.
Level M2, Blk A, Menara PKNS-PJ
Jalan Yong Shook Lin
46050 Petaling Jaya, Selangor, Malaysia
Tel: (603) 7949 9222
Fax: (603) 7949 9333

Middle East & Africa

Emerson Climate Technologies
PO Box 26382
Jebel Ali Free Zone – South
Dubai, UAE
Tel: (9714) 811 8100
Fax: (9714) 886 5465

Philippines

Emerson Climate Technologies
10/F SM Cyber West Avenue, EDSA cor.
West Avenue, Barangay Bungad, Diliman,
Quezon City 1105 Philippines
Tel: (632) 689 7200

South Korea

Emerson Electric Korea Ltd.
3F POBA Gangnam Tower
343, Hakdong-ro, Gangnam-gu,
Seoul 135-820, Republic of Korea
Tel: (822) 3483 1500
Fax: (822) 592 7883

Taiwan

Emerson Electric (Taiwan) Co. Ltd
3F No. 122 Lane 235,
Pao Chiau Rd., XinDian Dist.,
New Taipei City 23145, Taiwan (R.O.C.)
Tel: (8862) 8912 1360
Fax: (8862) 8912 1890

Thailand - Bangkok

Emerson Electric (Thailand) Ltd
34th Floor, Interlink Tower,
1858/133, Bangna Trad,
Bangkok 10260, Thailand
Tel: (662) 716 4700
Fax: (662) 751 4241

Vietnam

Emerson Climate Technologies - Vietnam
Suite 307-308,
123 Truong Dinh St., Dist.3
Ho Chi Minh, Vietnam
Tel: (84) 908 009 189

EmersonClimateAsia.com

Asia 02 B01 03-R00 Issued 03/2018 GSCAA066

Emerson, Copeland PerformanceAlert, CoreSense and Copeland Scroll are trademarks of Emerson Electric Co. or one of its affiliated companies. ©2018 Emerson Climate Technologies, Inc. All rights reserved.

EMERSON. CONSIDER IT SOLVED.™