

Copeland
1065 Big Shanty Road NW, Suite 100
Kennesaw, GA 30144 USA
770-425-2724 • 1-800-829-2724
www.copeland.com
Email: ColdChain.TechnicalServices@copeland.com

1 OVERVIEW OF THE MULTIFLEX CUB-II AND CUB-TD..... 1

1.1 The MultiFlex CUB-II.....1

1.2 The MultiFlex CUB-TD.....1

2 MOUNTING AND POWERING 2

2.1 Snap-Track Installation.....2

2.2 The Plug-In Output Board.....2

2.3 Powering the MultiFlex CUB Board3

2.3.1 Choosing Transformer Sizes3

2.3.2 MultiFlex CUB Power Wiring3

2.3.2.1 New-Style MultiFlex CUB Boards (With Isolated Power Supply)4

2.3.2.2 Old-Style MultiFlex CUB Boards (No Isolated Power Supply)4

2.3.3 Wire Types and Maximum Distances.....5

3 THE I/O NETWORK..... 6

3.1 Wiring Types.....6

3.1.1 Daisy Chains6

3.1.2 Network ID Numbers.....6

3.1.2.1 Numbering the MultiFlex CUB6

3.1.3 Setting the Baud Rate7

3.1.4 Setting the Terminating Resistance Jumpers7

4 CUB INPUT AND OUTPUT SETUP..... 8

4.1 The Inputs.....8

4.1.1 Connecting Sensors to the MultiFlex CUB.....8

4.1.1.1 Wiring8

4.1.1.2 Sensor Wiring Types.....8

4.1.1.3 Input Type Dip Switches8

4.1.2 Power Connection8

4.1.2.1 Current Ratings for On-Board Power Sources9

4.1.2.2 Powering Sensors Requiring 24VAC Off the Power Transformer9

4.1.3 MultiFlex CUB Fixed Input Locations.....9

4.2 The Outputs9

4.2.1 Relay Output Ratings and Fuse Protection.....10

4.2.2 Wiring Outputs to Points.....10

4.2.3 MultiFlex CUB Fixed Outputs.....11

5 BOARD STATUS LEDES..... 12

5.1 Status LED.....12

5.2 Tx and Rx LEDs.....12

5.3 Code A and Code B LEDs.....12

5.4 Relay Output LEDs.....12

6 MULTIFLEX CUB-II AND CUB-TD SOFTWARE OVERVIEW..... 13

6.1 Compressor Control.....13

6.1.1 Suction Pressure Compressor Control13

6.1.2 Case Temperature Compressor Control.....13

6.1.2.1 Pump Down13

6.1.2.2 Fallback Pressure Setpoints.....13

6.2 Condenser Fan Control.....13

6.2.1 Temperature Differential (TD) Strategy.....13

6.2.1.1 TD Control Fail-Safes.....13

6.2.2 Pressure Control Strategy.....14

6.2.3 Case Temperature Control14

6.3 Defrost Control 14
 6.3.1 Defrost Termination 14

6.4 Sensor Control..... 14
 6.4.1 How Cut In/Cut Out Control Works..... 14
 6.4.2 Motor Room Temperature Control..... 15
 6.4.2.1 Exhaust Fan Control..... 15
 6.4.2.2 Example of a Motor Room Zone Temperature Configuration..... 15

6.5 Alarm Conditions (Safety Modes) 15
 6.5.1 High Discharge Trip Safety Mode 16
 6.5.2 Compressor Proof Fail Safety Mode 16
 6.5.3 Compressor Oil Failure Safety Mode..... 16
 6.5.4 Phase Fail Mode 16

6.6 Door Switches and Clean (Wash) Switches..... 17
 6.6.1 Door Switches 17
 6.6.2 Clean (Wash) Switches..... 17

7 THE MULTIFLEX CUB E2/ EINSTEIN INTERFACE 18

7.1 Adding/Deleting a CUB 18
 7.1.1 Adding a CUB..... 18
 7.1.2 Deleting a CUB..... 19

7.2 Viewing the CUB Status Screen 19
 7.2.1 Inputs and Setpoints..... 20
 7.2.2 Sensor Control 21
 7.2.3 Outputs and Operational States..... 21
 7.2.4 Defrost..... 22
 7.2.5 KW Usage..... 22

7.3 Programming The CUB Using the E2 or Einstein Front Panel..... 22
 7.3.1 Screen 1: General..... 23
 7.3.2 Screen 2: Setpoints 24
 7.3.2.1 Temperature Differential (TD) 26
 7.3.2.2 Traditional Strategy..... 26
 7.3.3 Screen 3: Inputs..... 27
 7.3.4 Screen 4: Aux Inputs 27
 7.3.5 Screen 5: CUB Inputs..... 28
 7.3.6 Screen 6: Defrost..... 29
 7.3.7 Screen 7: Outputs 31
 7.3.8 Screen 8: CUB Outputs 32
 7.3.9 Screen 9: Sensor Control 33
 7.3.10 Screen 10: Alarms..... 34
 7.3.10.1 Oil Failure Alarm Setpoints..... 34
 7.3.10.2 Discharge Pressure Alarm 35
 7.3.10.3 High/Low Suction Pressure Alarms..... 35
 7.3.10.4 Compressor Proof Alarms..... 36
 7.3.10.5 Phase Fail Shutdown 36
 7.3.10.6 Door Switch Alarms 36
 7.3.10.7 Wash Active Alarms..... 36
 7.3.10.8 Case Temperature Alarms..... 37
 7.3.10.9 Suction Temperature Alarms 37
 7.3.10.10 TD Condenser Control Alarms..... 37

8 THE MULTIFLEX CUB HAND-HELD INTERFACE..... 38

8.1 CUB Hand-Held Terminal Status Screens 38

8.1.1 Pressure Status..... 38

8.1.2 Case Temp Status..... 38

8.1.3 Other Temperatures 38

8.1.4 Input Summary Screen..... 39

8.1.5 Outputs Summary Screen #1..... 39

8.1.6 Outputs Summary Screen #2..... 39

8.1.7 System Status..... 39

8.1.8 Refrigeration Control Status 39

8.2 Altering CUB Configuration Using The Hand-Held Terminal 39

8.2.1 The Main Configuration Menu 39

8.2.2 Navigation 40

8.2.3 General Hand-Held Terminal Screens..... 40

8.2.3.1 Circuit Name 40

8.2.3.2 Refrigerant Select 40

8.2.3.3 Phase..... 41

8.2.3.4 Temp EU..... 41

8.2.3.5 Time and Date..... 41

8.2.3.6 Daylight Savings Time 42

8.2.4 Setpoints Screens..... 42

8.2.4.1 Condenser Setpoints..... 42

8.2.4.2 TD Strat Info 42

8.2.4.3 TD Max..... 43

8.2.4.4 Comb Method 43

8.2.4.5 Min OFF/ON Times..... 43

8.2.4.6 Condenser SPs..... 44

8.2.4.7 Condenser Fan 1 Setpoints 44

8.2.4.8 Condenser Fan 2 Setpoints 45

8.2.5 Alarm Setpoints Screens..... 45

8.2.5.1 Case Hi and Lo Temp..... 45

8.2.5.2 Phase Fail..... 45

8.2.5.3 Shut Down On Proof 45

8.2.5.4 Proof Failure..... 46

8.2.5.5 Oil Restart Delay 46

8.2.5.6 Digital Oil Failure..... 46

8.2.5.7 High Discharge Alarm 47

8.2.5.8 High Discharge Auto Resets..... 47

8.2.5.9 Door Switch..... 47

8.2.5.10 Wash Switch..... 47

8.2.6 Defrost Setup Screens 48

8.2.6.1 Defrost Type..... 48

8.2.6.2 Fan Control..... 48

8.2.6.3 Defrost Times..... 48

8.2.6.4 Defrost Schedule Screens 1 and 2 49

8.2.7 Input Setup Screens 49

8.2.7.1 Input Setup..... 49

8.2.8 Outputs Screens..... 50

8.2.9 Auxiliary Inputs Screens..... 51

8.2.9.1 Pulse KW Setup 51

8.2.9.2 Analog KW Setup..... 51

8.2.9.3 Linear 1 and 2 Setup..... 51

8.2.10 Sensor Control Screens..... 51

8.2.10.1 Sensor Screen 1 (Name, Type)..... 51

8.2.10.2 Sensor Screen 2 (Cut In/Out, Min ON/OFF)..... 52

8.2.10.3 Sensor Screen 3 (Hi/Lo Alarm) 53

8.2.10.4 Sensor Control Screen 4 (Alarm Priority, Comb Method) 53

APPENDIX A: TD QUICK START 54

Set Up Motor Room Temperature and Plenum Temperature Inputs 54
 Global Data Setup Example 54

Configuring Setpoints in E2 or Einstein for CUB-TD 56
 Inputs..... 56
 CUB Inputs 56
 CUB Outputs..... 57
 General 57
 Setpoints 57
 Alarms..... 58

APPENDIX B: CASE TYPE DEFAULTS 59

REVISIONS..... 61

1 Overview of the MultiFlex CUB-II and CUB-TD

The MultiFlex CUB-II and CUB-TD boards are “smart” input/output boards designed to control single condensing units. A single condensing unit is a self-contained compressor and condenser bearing unit which controls refrigeration in a single case line-up or walk-in cooler. The MultiFlex CUB-II controllers are capable of commanding compressors, condensers, refrigeration, and defrost for a single condensing unit using on-board I/O and control algorithms. The CUB-TD controller is a more limited board that controls only condensers, using a temperature differential control strategy.

The MultiFlex’s I/O Points

The compact size of the MultiFlex allows technicians to easily field-mount the MultiFlex CUB-II and CUB-TD in a panel or enclosure close to the single condensing unit, allowing for easy local connection of sensors and transducers. The board has 16 analog inputs (for connection to vital input sources, such as suction pressure transducers and case temperature sensors) and eight relay outputs, rated 2.0 amps max, for activating and deactivating compressors, defrost, and condenser fans.

Independent System Control

The MultiFlex CUB-II and CUB-TD controllers are equipped with software and an enhanced processor, which gives them the capability of controlling independently without the need of a central controller (such as Copeland’s E2 or Einstein RX Refrigeration Controller). However, the CUB-II and CUB-TD are designed to interface with an E2 or Einstein for purposes of displaying status on status screens, reporting alarms, and recording logs. The CUB-II and CUB-TD may be configured either with the Copeland Hand-Held Terminal (HHT) or through the E2 or Einstein front panel.

1.1 The MultiFlex CUB-II

The MultiFlex CUB-II controllers are capable of handling all aspects of single condensing unit control, including compressors, condensers, refrigeration, and defrost, using on-board I/O and control algorithms. The CUB-II is capable of controlling one single-stage compressor, refrigeration and scheduled/terminated defrost in a case circuit with up to six temperature inputs, and condenser control using either a control by pressure strategy (activates up to two fans to maintain a set discharge pressure) or temperature differential strategy (activates up to four fans to maintain a set difference between the ambient temperature and the drop leg refrigerant temperature).

1.2 The MultiFlex CUB-TD

The MultiFlex CUB-TD is a “stripped” version of the MultiFlex CUB-II that includes only an algorithm for temperature differential (TD) condenser fan control. Up to four condensing unit fans are cycled on and off as required to meet compressor unit heat of rejection load. The TD algorithm subtracts plenum air temperature from the drop leg temperature and uses the difference between the two temperatures as a control value. If the difference is higher than the setpoint, the fans are staged on. If the difference is lower than the setpoint, the fans are staged off.

The temperature differential control capabilities of the CUB-TD are identical to those of a CUB-II operating in temperature differential mode, except the CUB-TD controls condensers only. The CUB-TD only has inputs for reading temperatures and outputs for controlling up to four fans. For control of any other single condensing unit subsystem, a CUB-II will necessary.

2 Mounting and Powering

The MultiFlex boards are usually mounted by the refrigeration equipment manufacturer. Therefore, the installer need only make the necessary connections between the boards and the site controller(s).

In some instances, an installer may be required to mount an I/O board. There are no restrictions on the location of these boards; however, for ease of network configuration, it is recommended that the boards be located adjacent to the E2 or Einstein. I/O boards may be mounted without an enclosure, but they should be mounted in a location that is not easily accessible to avoid tampering or damage.

2.1 Snap-Track Installation

MultiFlex boards not supplied in a custom panel or other enclosure are supplied with a snap-track for easy installation. The insulation sheet and I/O board must be removed from the track before the track is mounted. The snap-track is mounted using the 0.1875" mounting slots. **Figure 2-1** shows this installation procedure.

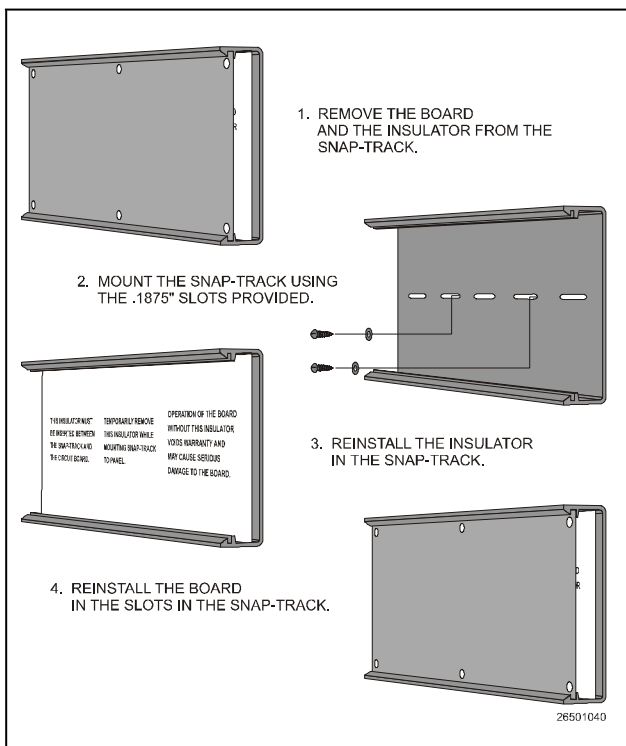

Figure 2-1 - MultiFlex Snap-Track Mounting

Figure 2-2 provides mounting dimensions for the MultiFlex board.

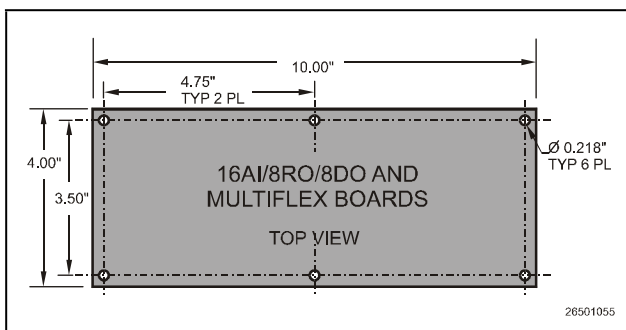

Figure 2-2 - MultiFlex Board Dimensions

2.2 The Plug-In Output Board

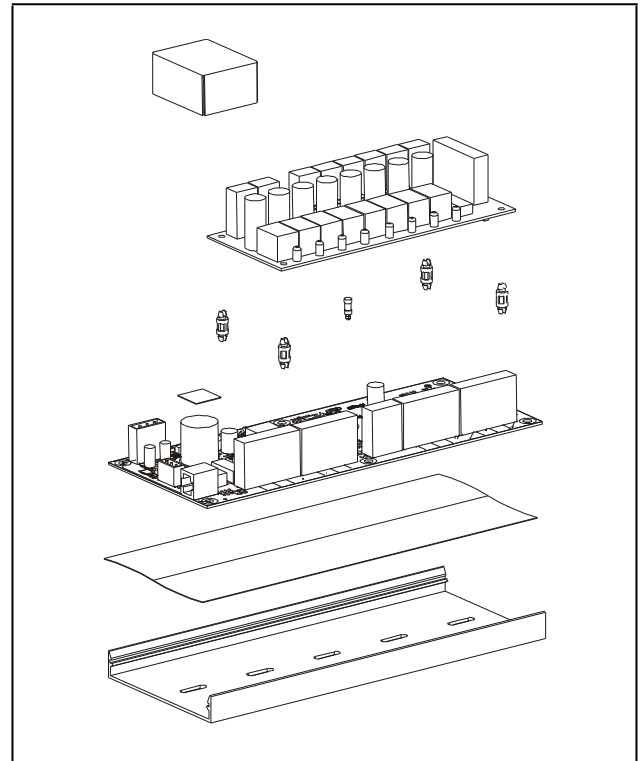

Figure 2-3 - Exploded View — MultiFlex CUB-II

The MultiFlex CUB has an output sub-board that plugs to the top of the baseboard. Typically, these boards are shipped with the output board pre-installed on the board using stand-offs, so no additional hardware setup should be necessary.

The additional board makes the MultiFlex CUB boards considerably taller than the MultiFlex 16 and other Copeland I/O boards. If you will be mounting these boards in an enclosure, the board will need at least 2.5" of clearance between the baseboard and the panel door.

2.3 Powering the MultiFlex CUB Board



WARNING

All models of MultiFlex require a 24VAC Class 2 input power source. The MultiFlex CUB-II requires the power source to be non-center-tapped. Refer to Section 2.3.1., Choosing Transformer Sizes for center tap usage.

Copeland supplies a wide variety of 24VAC transformers with varying sizes and either with or without center taps. **Table 2-1** shows the transformer sizes and whether they are center-tapped or non-center-tapped.

Table 2-1 - Transformers Compatible with Datalink Module

Xformer P/N	VA Rating	Primary Voltage	Center Tap?
640-0041	50 VA	110 VAC	No
640-0042	50 VA	220 VAC	No
640-0056	56 VA	Multi-tap (120/208/240 VAC)	Yes
640-0050	75 VA	110 VAC	No
640-0045	75 VA	220 VAC	No
640-0080	80 VA	Multi-tap (120/208/240 VAC)	Yes

2.3.1 Choosing Transformer Sizes

In most site installations, a single transformer will power multiple devices. Choose a transformer with a VA rating large enough to power all devices that will be attached to it.

Table 2-2 gives the VA ratings of the MultiFlex CUB in conjunction with other MultiFlex boards. Refer to your site controller's manual for VA ratings of the other I/O boards that may be powered by one of these transformers.

Table 2-2 - Device Power Requirements

Unit	VA	VAC	Center-Tapped?
MultiFlex 16	6	24	Yes
MultiFlex 88, 88AO, 168, and 168AO	15	24	No
MultiFlex RTU	15	24	No
MultiFlex CUB	15	24	No

2.3.2 MultiFlex CUB Power Wiring

The MultiFlex CUB boards do not use a center tap. Instead, the 0V terminal on the board should be connected to a separate earth ground.

Important! The rules that must be followed when connecting a MultiFlex CUB board to a transformer are different depending on whether you have a "new style" MultiFlex board with an isolated power supply (all MultiFlex boards shipped after November 1, 2002) or an "old style" MultiFlex board (all MultiFlex boards shipped before November 1, 2002).

A new-style MultiFlex board has a green power LED located next to the 24VAC connection terminal in the upper right corner of the circuit board (see **Figure 2-4** for reference).

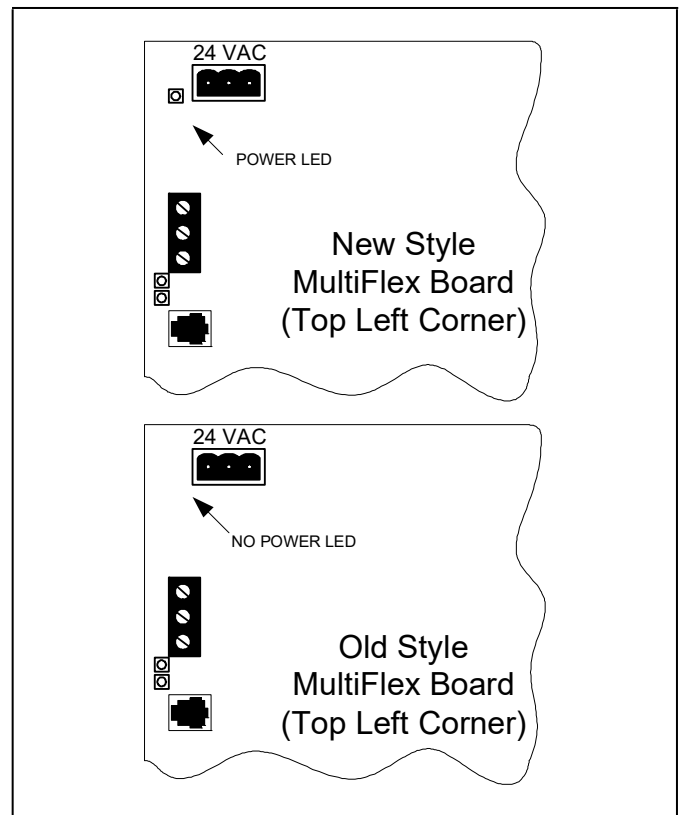

Figure 2-4 - New-Style vs. Old-Style MultiFlex Board

If there is a green power LED next to the connector, your MultiFlex is a new-style MultiFlex -- refer to **Section 2.3.2.1, New-Style MultiFlex CUB Boards (With Isolated Power Supply)** for power wiring instructions.

If there is no green power LED next to the connector, your MultiFlex is an old-style MultiFlex -- refer to **Section 2.3.2.2, Old-Style MultiFlex CUB Boards (No Isolated Power Supply)** for power wiring instructions.

2.3.2.1 New-Style MultiFlex CUB Boards (With Isolated Power Supply)

The new-style MultiFlex board can be connected to any of the center-tapped transformers mentioned in **Table 2-2**, provided the 0V terminal of the board is connected to an earth ground.

NOTE

14AWG or larger should be used for earth ground and the length should be kept short. Less than six inches is preferred.

A center-tapped transformer may power both center-tapped and non-center-tapped devices at the same time, as long as **none of the non-center-tapped MultiFlex boards are old-style MultiFlex boards**. If an old-style MultiFlex shares the same center-tapped transformer as a device that uses the center tap, the old-style MultiFlex will be damaged.

Figure 2-5 shows how to wire a non-center-tapped device to a center-tapped transformer.

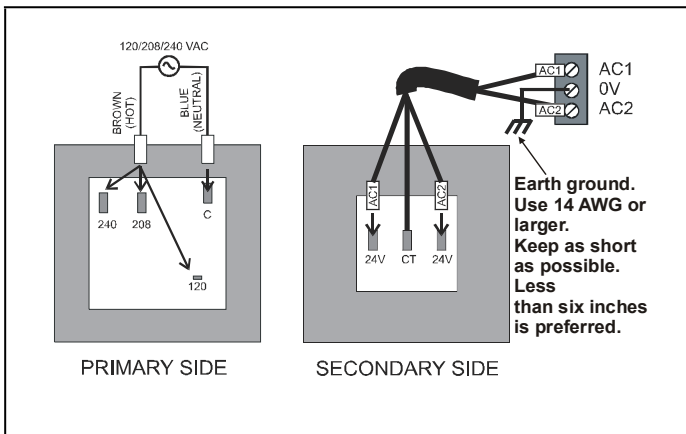

Figure 2-5 - Wiring Non-Center-Tapped MultiFlex Boards to Transformers With a Center Tap

In addition, the MultiFlex CUB boards can be powered by one of the 50VA or 75VA non-center-tapped transformers listed in **Table 2-1 on page -3**. **Figure 2-6** shows how to wire the transformers to the MultiFlex boards.

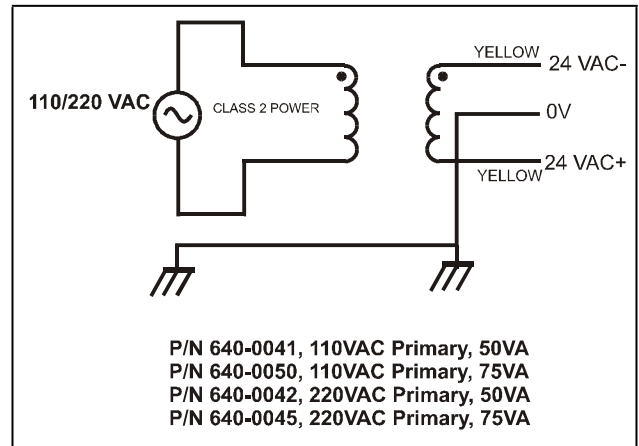

Figure 2-6 - Non-Center-Tapped Transformer Wiring

2.3.2.2 Old-Style MultiFlex CUB Boards (No Isolated Power Supply)

Like the new-style MultiFlex board, the old-style MultiFlex board can be connected to any of the center-tapped transformers mentioned in **Table 2-2**, provided you observe the following three rules:

Rule 1: Ground the 0V terminal on the old-style MultiFlex board to an earth ground.

Do not connect the center tap of the transformer to the 0V terminal.

Rule 2: Do not power an old-style MultiFlex non-center-tapped board with a transformer that is also powering a center-tapped device.

This means you cannot connect an old-style MultiFlex non-center-tapped board to a transformer that is powering a MultiFlex 16, 16AI, 8RO, 4AO, 8DO, or any previous generation Copeland board that uses center-tapped power. Doing so will destroy the MultiFlex board.

Rule 3: The secondary of the transformer must not be grounded on any side.

Verify that neither side of the transformer secondary is connected to earth ground before powering the old-style MultiFlex board. A grounded secondary will damage the MultiFlex board.

In addition, the old-style MultiFlex CUB boards can be powered by one of the 50VA or 75VA non-center-tapped transformers listed in **Table 2-1 on page -3**. **Figure 2-6** shows how to wire the transformers to the MultiFlex boards.

2.3.3 Wire Types and Maximum Distances

For powering I/O boards, use only the listed wire types from **Table 2-3**. Three-conductor non-shielded cables are the recommended wire for connecting between the center-tapped transformer and the I/O boards. Shielded cable should not be used for power wiring. The center tap should be wired with the third conductor to earth ground at the controller. (Use 14AWG and keep the length of wire short. Less than six inches is preferred).

Table 2-3 - Power Wiring Types

Power Wiring Types	
14 AWG	Belden 9495
18 AWG	Belden 9493

The wire length from the transformer and the number of boards connected to the same wire determines the type wire gauge used. In most cases, the distance between the I/O boards and the transformer that supplies power to them is not enough to be concerned with. But it is very important not exceed this maximum wire length or the boards will malfunction.

Use these formulas to determine if the wire gauge you are using fits within specification:

14 AWG:
Feet = $1920/VA$

18 AWG:
Feet = $739/VA$

(VA is the total VA rating of the I/O boards)

For example, if you had an 80 VA load:

14 AWG: 24 ft

18 AWG: 9 ft (rounded down)

Figure 2-7 - Power Wire Lengths

Sensors requiring 24VAC can be powered from the same transformer powering the input board as long as the resulting total load of both the input board(s) and the sensor(s) connected to the transformer does not exceed the transformer's VA rating, and the sensors have an isolated power supply. If the sensors do not have an isolated power supply, they could be damaged if connected with center-tapped or grounded secondary transformers.

3 The I/O Network

Although the MultiFlex CUB can operate as a stand-alone controller, it relies on an E2, Einstein, or REFLECS unit for advanced features such as remote dial-in/dial-out, logging, and alarm control. All MultiFlex boards and controllers use an RS485 Network connection to communicate with an E2, Einstein, and REFLECS site controllers. Technicians who are familiar with Copeland’s previous generation 16AI, 8IO, and ARTC boards will find the network setup procedure for the MultiFlex CUB boards to be very much the same.

3.1 Wiring Types

Copeland specs Belden #8761 shielded twisted pair cables for use as I/O Network wiring (or Belden #82761 and Belden #88761 for plenum installations).

If the recommended cable is not available in your area, be sure the wiring meets or exceeds the following specs:

Table 3-1 - RS485 I/O Network Wiring Specifications

Shielded?	Yes
Conductor Type	Twisted Pair
Gauge	18 - 24 AWG
Capacitance between signal wires	31 pF/ft or less
Capacitance between signal and shield	59 pF/ft or less
Nominal Impedance	120Ω±50Ω

3.1.1 Daisy Chains

The RS485 Input/Output (I/O) Network connects all input and output communication boards together in a single open communications loop. This loop, or “daisy chain,” connects the E2, Einstein, or REFLECS to multiple input and output communication boards, and terminates at the last input or output board on the network. A diagram of this network arrangement is shown in **Figure 3-1**.

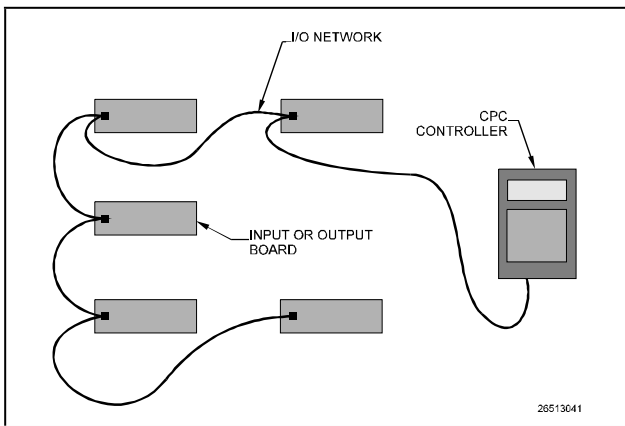

Figure 3-1 - I/O Network Configurations

3.1.2 Network ID Numbers

Each device on an RS485 segment has a network dip switch that must be used to assign the board a unique **network ID number**.

The network ID number makes a board unique from other boards on the network of the same type. This allows the site controller to find it and communicate with it easily.

Boards of the same type should be numbered in sequence, starting with one and continuing with two, three, and so forth.

3.1.2.1 Numbering the MultiFlex CUB

The MultiFlex CUB is a unique board type on the RS485 Network by the Copeland controllers. Each CUB that will be associated with an E2 or Einstein must have a unique number from 1 to 31, which is configured by setting the first five switches on dip switch bank S3.

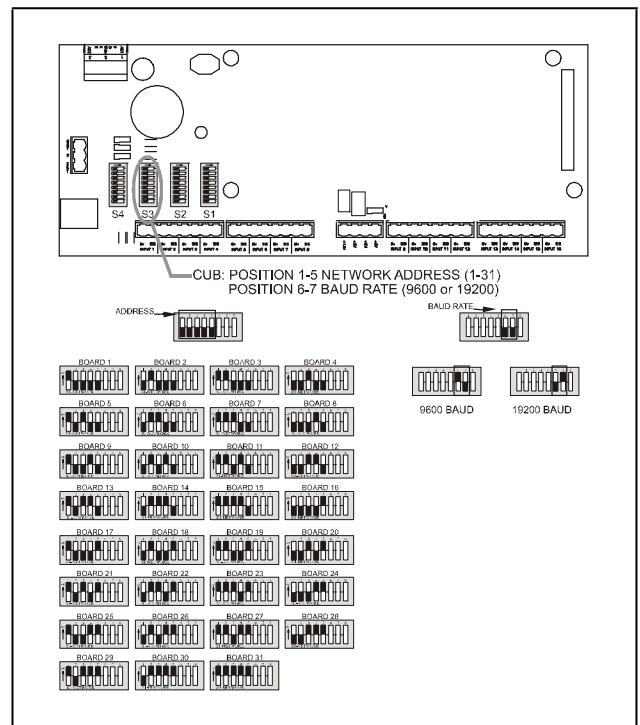

Figure 3-2 - CUB-II Baud Rate Switches

3.1.3 Setting the Baud Rate

All I/O boards have dip switches that determine the baud rate at which they communicate. Currently, the baud rate dip switch in network components may be set at either 9600 or 19200 baud. Either may be used — refer to your site controller’s user manual for the baud rate recommendation (currently 9600 baud for REFLECS, E2, and Einstein controllers).

On all MultiFlex boards, switches 6 and 7 on S3 are used to set the baud rate. To communicate at 9600 baud, set switch #6 UP and #7 DOWN. For 19200 baud, set switch #6 DOWN and #7 UP. Refer to **Figure 3-2** for a visual look at how the switches must be set.

3.1.4 Setting the Terminating Resistance Jumpers

All MultiFlex boards and other RS485 devices have a set of terminating resistance jumpers (one jumper for each wire lead). These jumpers are labeled JP2, JP3, and JP4 on the MultiFlex board.

The purpose of the jumpers is to indicate the two ends, or termination points, of the segment. On a daisy chain, one device at the beginning and one device on the end must be terminated by placing all three termination jumpers in the OUT (toward the left edge of the board) position. All other devices on the daisy chain must be set to the IN (toward the center of the board) position. **Figure 3-3** shows the proper terminating resistance jumper settings for the E2, Einstein, and for all I/O boards.

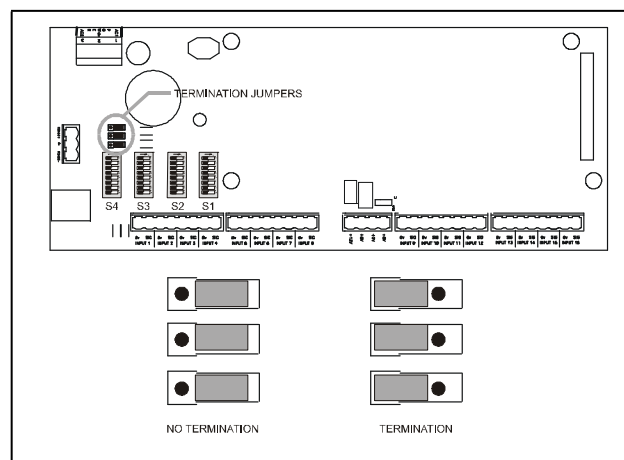

Figure 3-3 - I/O Network Termination Jumper Settings

4 CUB Input and Output Setup

4.1 The Inputs

4.1.1 Connecting Sensors to the MultiFlex CUB

Wiring an input to the input points on a MultiFlex board requires three steps:

1. Connect the sensor's signal wires to the two terminals of an input point.
2. Set the input type dip switch that corresponds to the point being connected.
3. If necessary, connect the sensor to one of the 5V or 12V power terminals.

4.1.1.1 Wiring

An input point on a MultiFlex board consists of two terminals, as shown in **Figure 4-1**. One of these terminals, labeled **SIG**, reads the signal from the sensor, while the other, labeled **0v** is where the sensor's ground and/or cable shield wire is connected.

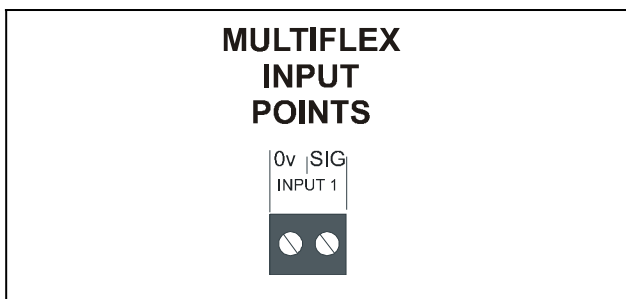

Figure 4-1 - Input Board Points

4.1.1.2 Sensor Wiring Types

Specific wiring types are required for each type of sensor used with E2, Einstein, or RMCC.

All Analog Temperature Sensors and Air Flow Sensors

Temperature and air flow sensors are to be wired with shielded, 2 conductor, at least 22 GA wire (Belden # 8761 or equivalent).

All Pressure Transducers, Humidity Sensors, and Refrigeration Transducers

Pressure and refrigeration transducers and humidity sensors are to be wired with shielded, 3 conductor, at least 22 GA wire (Belden #8771 or equivalent).

Dewpoint and Light Level Sensors

These sensors are to be wired with shielded, 4 conductor at least 22 GA wire (Belden # 8729 or equivalent).

4.1.1.3 Input Type Dip Switches

Each MultiFlex input point has an input type dip switch that must be set. Input type dip switches are located in the switch banks labeled S1 and S2.

The input type dip switch tells the input board whether or not the sensor connected to the point is a resistive type sensor. Generally, if the sensor or transducer supplies its own voltage signal to the point, the dip switch should be set to the LEFT position. If the sensor uses variable resistance and requires voltage to be supplied to it from the input point, set the dip switch to the RIGHT position. Dip switches for unused points should be set to the RIGHT position.

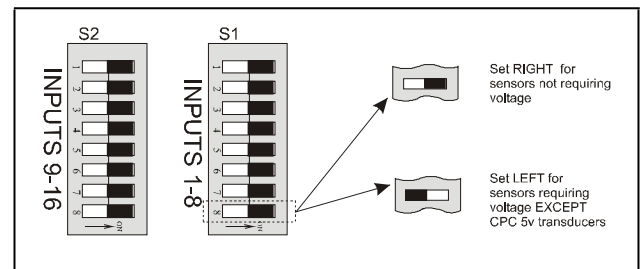

Figure 4-2 - Input Type Dip Switches for CUB Board

4.1.2 Power Connection

If power is needed to operate the sensor, four points are provided on the MultiFlex board that supply DC power: one +12VDC point, and three +5VDC points. See **Figure 4-3** for the location of these points.

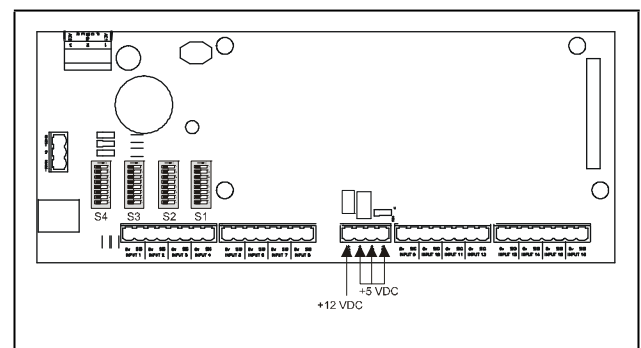

Figure 4-3 - Input Board Power Sources

To connect to one of the DC power sources, simply connect the sensor's power wire to one of the terminals.

A sensor that requires 24VAC can be powered off the MultiFlex's own 24VAC power connection. To connect to the 24VAC power source, connect the sensor's power wires to terminals AC1 and AC2.

4.1.2.1 Current Ratings for On-Board Power Sources

The maximum current that may be drawn from the +12VDC terminal is 100 milliamps. The maximum current that can be drawn from all three +5VDC terminals COMBINED is 50 milliamps.

4.1.2.2 Powering Sensors Requiring 24VAC Off the Power Transformer

Some sensors that requires 24VAC can be powered off the MultiFlex’s own 24VAC power connection. To connect to the 24VAC power source, connect the sensor’s power wires to terminals AC1 and AC2.

This can only be done with sensors that keep the 24VAC signal isolated from its DC output signal (such as Copeland’s Dewpoint Probe). If the output signal is not isolated from the 24VAC input, you must use a separate transformer.

4.1.3 MultiFlex CUB Fixed Input Locations

The MultiFlex CUB supports a large number of different types of input sources that might be found on a single condensing unit’s pressure control, condenser control, or refrigeration control systems. Because input locations are specified by the user in the system software, you can connect inputs from the condensing unit to any point on the CUB. However, to make setup easier, the CUB has assigned default sensor locations to a few of the inputs on the board.

4.2 The Outputs

The MultiFlex CUB has eight relays that energize and de-energize to control output loads.

When setting up an output on one of these relays, you must make two important decisions:

1. Do you want an ON command from your controller to mean “energize the relay” or “de-energize the relay,” and
2. When the relay is de-energized, as is the case when the CUB goes offline or loses power, do you want the contacts to be OPEN or CLOSED?

Decision #1 is made by setting the **fail-safe switch**. This is a bank of eight switches on the plug-in output module. Each switch corresponds to an output on the board (switch #1 = output #1, etc.).

Decision #2 is made either by setting a **fail-safe jumper** (for the MultiFlex CUB) or by wiring the load to either the N.O. or N.C. terminals on the Form C contact (for the MultiFlex 16I8O).

Table 4-2 shows how the fail-safe switch and Form C contacts should be configured based on how you want the output to perform during both normal operation and during network/power loss.

Table 4-1 lists the inputs with assigned defaults. If you choose to not use the defaults listed, you may change any or all of them in the system software (see **Section 7.3.3, Screen 3: Inputs** and **Section 8.2.7, Input Setup Screens**).

Table 4-1 - CUB Default Inputs

CUB Input Point Number	Label	Sensor to Connect To This Point
1	Suction Transducer	0-100PSI Pressure Transducer, measuring suction pressure
2	Discharge Transducer	0-500PSI Pressure Transducer, measuring discharge pressure
3	Oil Transducer	0-200PSI Pressure Transducer, for measuring oil pressure
4	Case 1 Temp	Discharge air temperature sensor for the cooler or case lineup
16	Alarm Reset	Digital contact closure (switch or push button) to reset alarms

Table 4-2 - Output Board Fail-Safe and Switch Settings

HHT Display	Contact State	Equipment State	Fail Safe	Set Failsafe Switch To:	Form C Contacts Used:
ON OFF	CLOSED OPEN	ON OFF	ON	UP	N.C
ON OFF	OPEN CLOSED	OFF ON	OFF	UP	N.O
ON OFF	CLOSED OPEN	OFF ON	OFF	UP	N.C.
ON OFF	CLOSED OPEN	OFF ON	ON	DOWN	N.O
ON OFF	OPEN CLOSED	ON OFF	OFF	DOWN	N.C
ON OFF	CLOSED OPEN	ON OFF	OFF	DOWN	N.O

4.2.1 Relay Output Ratings and Fuse Protection

Each relay output on the MultiFlex Combination I/O boards is rated for up to 240 VAC with a maximum current of 2 amps.

Each relay is fused with a 2 amp fast-blow 5mm x 20mm fuse, Bussman GMA-2 or equivalent.

4.2.2 Wiring Outputs to Points

The MultiFlex CUB has Form C relay contacts. **Figure 4-4** shows how to wire the three-terminal Form C contact.

One wire of the two-wire connection should always be connected to the middle terminal. The second wire must either be connected to the N.C. terminal (if you want the path to be closed when the relay is de-energized) or the N.O. terminal (if you want the path to be open during power failure).

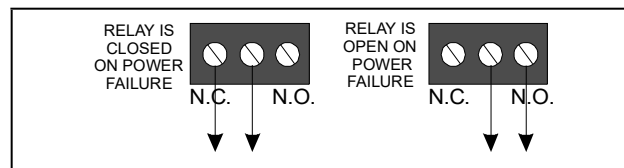

Figure 4-4 - Form C Contact Wiring

4.2.3 MultiFlex CUB Fixed Outputs

The MultiFlex CUB supports a large number of different types of output devices that might be found on a single condensing unit's pressure control, condenser control, or refrigeration control systems. Because output locations are specified by the user in the system software, you can connect outputs from the condensing unit to any point on the CUB. However, to make setup easier, the CUB has assigned default sensor locations to a few of the inputs on the board.

Table 4-1 lists the inputs with assigned defaults. If you choose to not use the defaults listed, you may change any or all of them in the system software (see **Section 7.3.7, Screen 7: Outputs** and **Section 8.2.8, Outputs Screens**).

Table 4-3 - CUB Default Outputs

CUB Output Point Number	Label	Device to Connect To This Point
1	Compressor	Compressor
2	Defrost	Electric defrost heaters or hot gas valve
3	Condenser Fan # 1	Condenser fan (or 1st condenser fan if multiple fans are present)
8	Alarm Output	Digital contact closure that is ON when an alarm condition is active in the condensing unit.

5 Board Status LEDs

When a MultiFlex board is powered up, you will be able to determine the operating status of the board by observing its status LEDs. **Figure 5-1** shows the location of the MultiFlex's status LEDs.

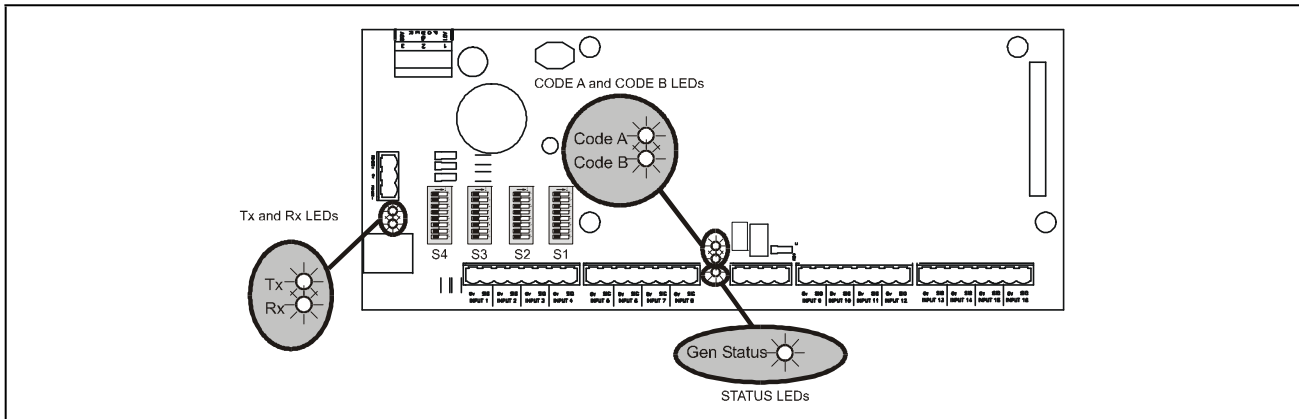

Figure 5-1 - MultiFlex Status LED Locations

5.1 Status LED

The Status LED blinks green once per second to show that the board is powered and operational. If this light is dark, the board has likely lost power.

5.2 Tx and Rx LEDs

The Tx and Rx LEDs indicate when the MultiFlex is sending or receiving messages on the RS485 Network.

The Tx LED blinks once every time the MultiFlex sends a response to the E2, Einstein, or REFLECS. The Rx LED blinks once when the MultiFlex receives a message.

If the MultiFlex is connected to the network and set up to communicate with the controller, you should see these lights blinking regularly. If they do not, there may be a problem with the network.

5.3 Code A and Code B LEDs

All MultiFlex models except the MultiFlex 16 have two LEDs labeled Code A and Code B. These LEDs indicate failure conditions. When these LEDs are OFF, there are no failures active. When one or both of these LEDs are blinking, there are failure conditions. The rate of blinking indicates the type of failure:

Code A Failure Conditions

- **Blinking fast (4 times/second)** - There is a problem with the flash memory or hardware clock on this board. This generally means the board is bad and must be replaced.
- **Blinking slow (1 time/second)** - The board is not receiving any messages addressed to it. This means either the I/O Network is down or it has not yet been commissioned in the E2, Einstein, or REFLECS Network Configuration screen.

Code B Failure Conditions

- **Blinking 2 times/second** - The battery on this board that backs up the CUB configuration during power failures has failed. If you see this light flashing, the battery will need to be replaced to avoid loss of configuration. Also, check the position of the Enable Battery jumper, located at the bottom right of the board just underneath the output plug-in board. If this jumper is set to the DOWN position, move it to the UP position. This will enable the battery and should cause the Code B light to stop flashing.

5.4 Relay Output LEDs

Each relay output point on a MultiFlex has an indicator LED that shows the status of the output. This LED is lit to show the output is ON, and unlit to show the output is OFF.

The definition of ON and OFF in this case is determined by the position of the fail-safe dip switch (see **Table 4-2**). Therefore, if the output's switch is UP, a lit LED means the path is CLOSED for N.C. contacts and OPEN for N.O. contacts.

6 MultiFlex CUB-II and CUB-TD Software Overview

The CUB-II is capable of controlling all vital systems of a single condensing unit, including compressors, condenser fans, evaporators and case circuit systems. Extended logging and alarm control capabilities require connection to an E2 or Einstein RX refrigeration controller.

6.1 Compressor Control

Since a single condensing unit has a single compressor, the MultiFlex CUB-II's pressure control strategy uses simple Cut In/Cut Out strategy for activating and deactivating the compressor. The compressor may be controlled either by suction pressure or case temperature.

6.1.1 Suction Pressure Compressor Control

Using the Suction Pressure Control strategy, the CUB-II compares the suction pressure to a set of Cut In/Cut Out setpoints. If the suction pressure rises higher than the Cut In setpoint, the compressor is activated and remains activated until the suction pressure falls below the Cut Out setpoint.

To prevent short-cycling of the compressor, minimum ON and OFF times may be used in this strategy.

6.1.2 Case Temperature Compressor Control

Using the Case Temperature Control strategy, the CUB-II only activates the compressor when refrigeration is necessary in the case. This strategy uses a temperature setpoint and a deadband. When the case temperature is above the setpoint plus one-half the deadband, the compressor will turn ON and will remain ON until the case temperature falls below the setpoint minus one-half the deadband.

NOTE

A suction transducer is required even for temperature control and is used to prevent the compressor from operating below the minimum suction pressure setpoint.

6.1.2.1 Pump Down

If the CUB-II is using the Temperature strategy, it also has the option of using a special Pump Down mode to pump refrigerant out of the evaporator coil when going from Refrigeration to Idle or from Refrigeration to Defrost.

A Pump Down causes the refrigeration solenoid to shut while keeping the compressor ON. The compressor will remain ON until the suction pressure drops below a minimum setpoint (or until a fail-safe time elapses).

Idle Pump Down With Door Switches

If a door switch is available and Idle Pump Down mode is enabled, the CUB-II will do a Pump Down every time a door switch is activated.

6.1.2.2 Fallback Pressure Setpoints

When in Temperature strategy, if the case temperature sensors fail or the CUB-II is otherwise unable to determine the case circuit air temperature, the CUB-II will cease operating in Case Temperature Compressor Control mode and use fallback suction pressure Cut In/Cut Out setpoints to control the compressor. This fallback mode operates exactly like the Suction Pressure Compressor Control mode described in **Section 6.1.1, Suction Pressure Compressor Control**

The CUB-II will continue to operate using the fallback pressure setpoints until a case temperature sensor value becomes available. The CUB-II will then resume Temperature strategy control.

6.2 Condenser Fan Control

6.2.1 Temperature Differential (TD) Strategy

Temperature differential strategy attempts to keep a minimum amount of difference between the temperature of the refrigerant and the ambient temperature.

The CUB-II and CUB-TD temperature differential strategy uses drop leg temperature for the refrigerant temperature and plenum temperature for the ambient temperature. The formula for determining the TD control value is:

$$TD = (\text{dropleg temp}) + (\text{dropleg offset}^*) - \text{plenum temp.}$$

*DropLeg Offset is a user-configured parameter to allow fine-tuning of the drop leg temperature measurement.

In TD condenser control operation, when the TD rises above $TD \text{ setpoint} + (TD \text{ deadband} / 2)$, an increase in fan capacity is called for. Similarly, when the TD drops below $TD \text{ setpoint} - (TD \text{ deadband} / 2)$, a decrease in fan capacity is called for. TD can control up to four condenser fans.

6.2.1.1 TD Control Fail-Safes

TD control operates as explained in **Section 6.2.1, Temperature Differential (TD) Strategy** as long as plenum and drop leg temperature inputs are available and the drop leg temperature remains within a minimum/maximum range configured by the user. Otherwise, TD control uses various fail-safe modes to maintain proper operation of condenser control.

Drop Leg Temperature Not Available

In the event drop leg temperature is not available (due to probe failure), all fan stages will be staged on.

Drop Leg Temperature Above Maximum Drop Leg Setpoint

If the drop leg temperature (DropLeg Temp) rises above the maximum drop leg temperature setpoint (DropLeg Max), an increase will be called for until DropLeg Temp drops below DropLeg Max. This protects against the possibility of the DropLeg Temp rising too high as a result of high plenum temperature.

Drop Leg Temperature Below Minimum Drop Leg Setpoint

If the drop leg temperature drops below the minimum drop leg temperature setpoint (DropLeg Min) a decrease will be called for until DropLeg Temp rises above DropLeg Min. This protects against the possibility of the DropLeg Temp falling too low as a result of low plenum temperature.

Plenum Temperature Not Available

If plenum temperature is not available (due to probe or communication failure), control will be based on the DropLeg Min and Max setpoints.

6.2.2 Pressure Control Strategy

Pressure control strategy uses Cut In/Cut Out setpoints for control based on discharge pressure. The CUB-II can control a maximum of two fans using this strategy. This strategy is not available in the CUB-TD.

Traditional strategy condenser fan control simply compares the value of the discharge pressure transducer to a set of Cut In/Cut Out setpoints for each fan. If the discharge pressure rises above the Cut In setpoint for a fan, that fan will turn ON and will remain active until the discharge pressure falls below the fan's Cut Out setpoints.

Condenser fans may be programmed with a minimum ON time to prevent short-cycling.

6.2.3 Case Temperature Control

Case temperature control supports using a combination of up to six case temperature inputs as the control input. The CUB-II also supports multiple strategies for combining multiple case temp inputs, including minimum temp, maximum temp, and average temp.

6.3 Defrost Control

The CUB-II controls scheduled defrosts for its case circuit, and supports both electric and off-cycle (or timed) defrost. Up to 12 daily scheduled defrost times can be programmed in the CUB-II memory. The CUB-II executes defrost cycles at each scheduled time.

6.3.1 Defrost Termination

The CUB-II allows for defrost termination based on temperature or suction pressure. Temperature termination can use either a digital defrost sensor (or Klixon) or an analog termination sensor, whose value is compared to the termination setpoint. Suction pressure termination will terminate a defrost cycle when the suction pressure rises above a programmed suction pressure termination setpoint.

Defrost cycles may be programmed with a minimum defrost time and a maximum defrost time.

6.4 Sensor Control

The CUB-II provides for up to two generic Cut In/Cut Out control algorithms for use in controlling subsystems related to the condensing unit. Each sensor control application consists of an input (or a set of inputs combined into a single value), a set of Cut In/Cut Out setpoints, and a digital output that is controlled by comparing the input to the setpoints.

Typical uses for a sensor control application on a CUB-II include: refrigerant leak detection, motor room temperature control, and case lights.

6.4.1 How Cut In/Cut Out Control Works

Cut In/Cut Out setpoints work differently depending upon whether the Cut In/Cut Out setpoint is higher.

Cut In Higher Than Cut Out

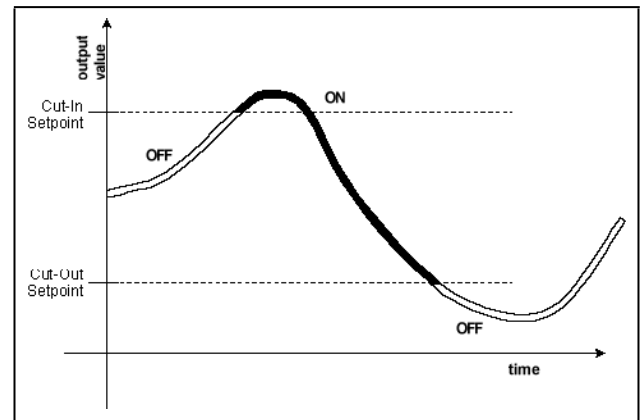

Figure 6-1 - Cut In Setpoint Higher than Cut Out

When the Cut In setpoint is higher than the Cut Out setpoint, the Sensor Control output turns ON when the sensor input goes higher than the Cut In setpoint. The Sensor Control output remains ON until the input falls below the Cut Out setpoint, at which time the output turns OFF. (See **Figure 6-1** for an illustration).

Cut In Lower Than Cut Out

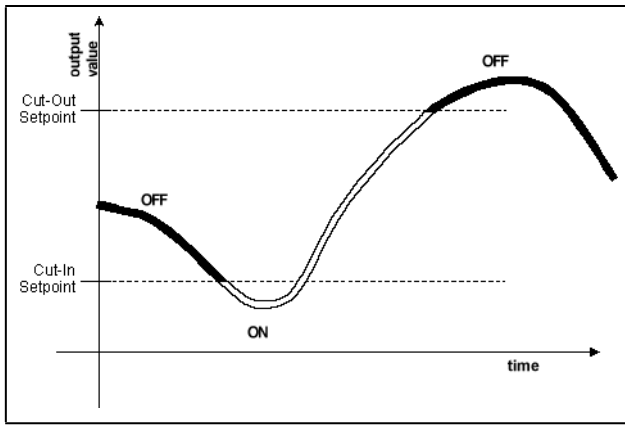

Figure 6-2 - Cut In Setpoint Lower Than Cut Out

When the Cut In setpoint is lower than the Cut Out setpoint, the Sensor Control output turns ON when the sensor input goes lower than the Cut In setpoint. The Sensor Control output remains ON until the input rises above the Cut Out setpoint, at which time the output turns OFF. (See Figure 6-2 for an illustration).

6.4.2 Motor Room Temperature Control

Part of the capabilities of sensor control involves the control of temperature in a motor room.

The CUB-II takes a “zone control” approach to controlling motor room temperature. All the CUB-IIs attached to a single E2 or Einstein can be divided into up to four “zones” (physically, up to four different motor rooms). In each zone, one CUB-II must be set up with a sensor control input designated as “Motor Room Temp.” This temperature value is shared with E2 or Einstein’s Global Data handler, and passed back down through Global Data to all CUB-IIs that share the same zone number.

In an E2 or Einstein that has CUB-II boards attached to it, the Global Data values SPARE ANLG01 through SPARE ANLG04 are reserved for motor room temperatures in zones 1-4. If, for example, a CUB-II in zone 2 has a “Motor Room Temp” sensor control input, E2 or Einstein will read this value into Global Data as SPARE ANLG02. All other CUB-IIs that are assigned to zone 2 will read SPARE ANLG02 as the motor room temp.

6.4.2.1 Exhaust Fan Control

The CUB-II in each zone that is reading the motor room temp may also use the input to perform Cut In/Cut Out control of a single output. This can drive an exhaust fan or similar HVAC device.

6.4.2.2 Example of a Motor Room Zone Temperature Configuration

An example of how motor room temperature zone control is shown in Figure 6-3. In this example, there are two motor rooms with five CUB-IIs each. Each motor room has an exhaust fan that is controlled by the same CUB-II that has the motor room temp probe. This fan is controlled entirely by the individual CUB-II.

The motor room temperature for Zones 1 and 2 are passed to E2 or Einstein as the Global Data values SPARE ANLG01 and SPARE ANLG02. All the CUB-IIs in Zone 1 except the one with the sensor will read the SPARE ANLG01 Global Data value as their zone’s motor room temp, and will display this value on their HHT status screens.

⚠ WARNING

If you are using CUB-IIs, you cannot use Global Data’s SPARE ANLG 01 through 04 inputs for any purpose other than motor room temperature control. If you need to use some of Global Data’s “Spare Analog” slots to share values between E2s or Einsteins, use SPARE ANLG 05 through 08.

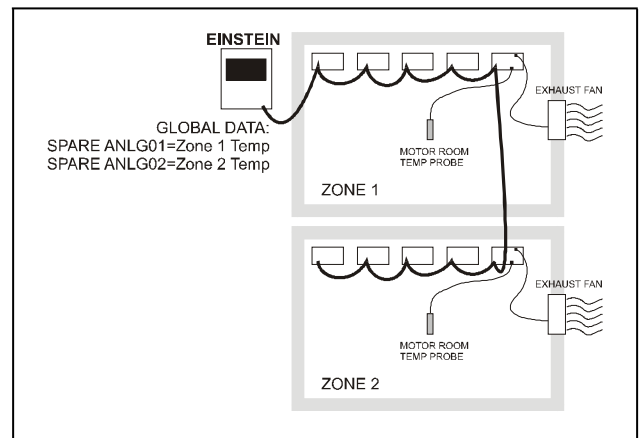

Figure 6-3 - Example of Zone Temperature Control Setup

6.5 Alarm Conditions (Safety Modes)

When certain conditions are detected, the CUB-II and CUB-TD operate in a special mode (called **Safety mode**) in order to correct the condition or to prevent equipment, product, and/or energy loss. Safety mode alarm conditions can be reset two different ways:

1. Resetting the alarm in the E2 or Einstein Alarm Log will reset all active Safety mode alarms.
2. Defining an alarm reset input on the CUB-II, and then manually closing the input will reset all active Safety mode alarms.

6.5.1 High Discharge Trip Safety Mode

The CUB-II will always try to prevent the condensing unit's discharge pressure from rising above a user-defined setpoint, called the **discharge trip setpoint**. If the discharge pressure ever rises above this setpoint, the CUB will enter the **High Discharge Trip Safety** mode. This will lock the compressor OFF, and cause the Circuit State of the CUB to display Rack Fail in the E2 or Einstein and HHT status screens.

Resetting a High Discharge Trip

Resetting a high discharge trip safety mode can be done manually by closing the **Alarm Reset input** on the CUB-II or by resetting the **High Discharge Trip alarm** in the E2 or Einstein alarm log.

You can also program the CUB-II to auto-reset when the discharge pressure falls below the discharge trip setpoint minus a user-defined differential. This ensures the pressure will drop well below the trip setpoint before re-starting the compressor.

When using auto-reset, you may also set a maximum number of auto-reset attempts. The CUB will only attempt an auto-reset if it has not already auto-reset the CUB a number of times in the past hour equal to the user-defined maximum. If CUB's auto-reset maximum has already been met, it will remain in High Discharge Trip mode until it is manually reset.

6.5.2 Compressor Proof Fail Safety Mode

If the CUB-II has a Compressor Proof input configured, it can use this input to verify the compressor is operating properly. Under normal conditions, the CUB-II will expect the proof input to mirror the state of the compressor at all times (i.e., proof registers ACTIVE when the compressor is ACTIVE, and INACTIVE when the compressor is INACTIVE). If the proof input does not mirror the value of the compressor state for a period of time longer than a user-defined period, the CUB-II will enter Proof Fail mode.

In **Proof Fail** mode, you may either choose to program the CUB-II to shut down the compressor until the failure is cleared, or to keep attempting to activate/deactivate the compressor as normal.

Resetting a Compressor Proof Failure

Resetting a **Compressor Proof Failure Safety** mode can be done manually by closing the **Alarm Reset input** on the CUB or by resetting the **Compressor Proof Fail alarm** in the E2 or Einstein alarm log.

You can also program the CUB-II to auto-reset when the proof input state indicates the compressor is physically behaving as commanded. When using auto-reset, you may also set a maximum number of auto-reset attempts. The CUB-II will only attempt an auto-reset if it has not already auto-reset the CUB-II a number of times in the past hour equal to the user-defined maximum. If CUB-II's auto-reset maximum has already been met, it will remain in Compressor Proof Fail mode until it is manually reset.

6.5.3 Compressor Oil Failure Safety Mode

The CUB-II can monitor compressor oil pressure using either an oil pressure transducer or a digital oil pressure switch. When a low oil pressure condition occurs, CUB-II can be programmed to lock the compressor OFF to prevent equipment damage.

Resetting an Oil Failure

Resetting an **Oil Fail Safety** mode can be done manually by closing the **Alarm Reset input** on the CUB or by resetting the **"Oil Failure" alarm** in the E2 or Einstein alarm log.

You can also program the CUB-II to auto-reset when the oil failure input state indicates the oil pressure has returned to normal. When using auto-reset, you may also set a maximum number of auto-reset attempts. The CUB-II will only attempt an auto-reset if it has not already auto-reset the CUB-II a number of times in the past hour equal to the user-defined maximum. If CUB-II's auto-reset maximum has already been met, it will remain in Oil Fail mode until it is manually reset.

6.5.4 Phase Fail Mode

If a phase fail checking device is present on-site, the CUB-II can be programmed to shut down multiple-phase devices it controls.

To enable phase protection, a digital phase fail checking device must be connected to one of the CUB-II's physical inputs. When this input signifies a phase failure has occurred, the CUB-II immediately shuts down the compressor, the condenser fans, and the defrost output. CUB-II will lock these devices OFF until the phase failure is over.

NOTE

CUB-II will not lock out evaporator fans when a phase fail occurs, because these are single-phase devices.

6.6 Door Switches and Clean (Wash) Switches

The MultiFlex CUB-II has special modes of operation to accommodate use of freezer door switches and clean (or wash) switches.

6.6.1 Door Switches

If the CUB-II is controlling refrigeration in a walk-in freezer or other case type that has a door switch equipped, the CUB-II may be programmed to shut off the compressor and fans when the door is open. The CUB-II will lock the compressor and case fans OFF until the door is closed, at which time it will resume normal refrigeration control.

The CUB-II may be programmed with an **alarm time** and a **fail-safe time**. If the door is open longer than the alarm time, the E2 or Einstein controlling the CUB-II will generate an alarm to warn store personnel that the door has been left open. If the door is open longer than the fail-safe time, the CUB-II will resume refrigeration to prevent product loss.

6.6.2 Clean (Wash) Switches

Some refrigerated cases may be outfitted with **clean switches** (also called "**wash switches**") that disable all case systems so that they may be cleaned or serviced. The CUB-II will respond to a contact closure of a clean switch by locking the compressor, defrost, and case fans OFF for as long as the switch is active.

The CUB-II may be programmed with a fail-safe time to prevent the case from being in clean mode for too long. If this fail-safe time is passed, the CUB-II will resume normal control regardless of the position of the clean switch.

7 The MultiFlex CUB E2/ Einstein Interface

NOTE

In this section of the manual, the term "CUB" will be used to mean "CUB-II and, if appropriate, CUB-TD." Not every instruction and system setup in this section will apply to the CUB-TD (only those related to TD condenser control).

The MultiFlex CUB-II and CUB-TD are capable of communicating with an E2 (all versions) or an Einstein RX refrigeration controller with software version 1.82 or above.

Using MultiFlex CUB-II and CUB-TD boards with a central E2 or Einstein controller offers several benefits over simple stand-alone control, including:

- Reporting of CUB-related alarms in the Alarm Advisory Log
- The ability to log CUB inputs in an E2 or Einstein logging group
- The ability to share outside air temperature values and control motor room temperature by sharing input values between the CUB and the E2 or Einstein
- Remote access to CUB status and programming from both the E2 or Einstein front panel
- The ability to remotely access CUBs from UltraSite32, and to back up, restore, and offline program CUB configuration along with E2 or Einstein site configuration

Communication between E2 or Einstein and a CUB takes place over the RS485 I/O Network. Follow the instructions in **Section 3, The I/O Network**, to connect the CUBs to the E2 or Einstein I/O Network. Then, follow the instructions in this chapter to set up the CUBs.

7.1 Adding/Deleting a CUB

7.1.1 Adding a CUB

Before an E2 or Einstein will communicate with a CUB, it must be added as an I/O board. This task is performed in the **Controller Setup** screen. To access this screen:

Einstein	E2
1. Log in to the Einstein.	1. Log in to the E2
2. Press F8, Y to access the System Configuration Menu .	2. Press the MENU  key.
3. Press 4 - Network Status/Setup .	3. Press & 7 to navigate to the System Configuration Menu .
4. Press 2 - Connected I/O Boards & Controllers .	4. Press & 7 to navigate to the Network Status/Setup menu.
5. Enter the number of CUB boards that will be networked with this Einstein in the CUB Controllers field.	5. Press @ 2 - Connected I/O Boards & Controllers .
	6. Enter the number of CUB boards that will be networked with this Einstein in the CUB Controllers field.

NOTE

On the Network Setup screen, "CUB Controllers" refers to both CUB-IIs and CUB-TDs. If you have both CUB-IIs and CUB-TDs, enter the total amount of both types of boards.

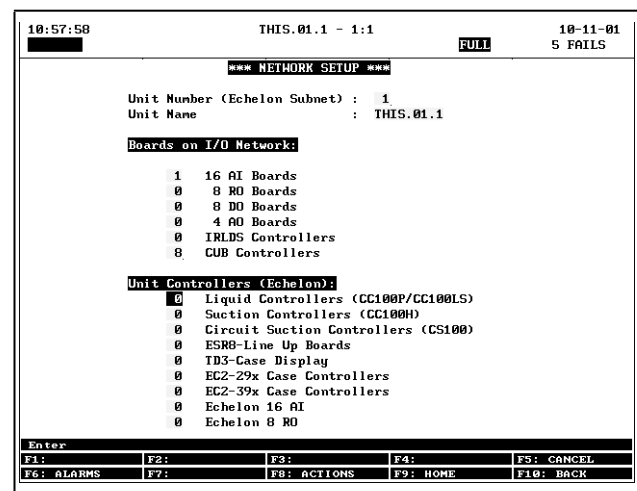



Figure 7-1 - Controller Setup Screen

If you have properly set up all MultiFlex CUB boards on this E2 or Einstein's I/O Network, you can go view the status of the **I/O Network** (press **F10** or the  key to go back to the menu, then press **3 - Controller Status**). If E2 or Einstein and the CUB boards are communicating, this screen will show the CUB boards as **Online**. If not, they will be shown as **Offline**.

7.1.2 Deleting a CUB



To remove a CUB from the E2 or Einstein:

Einstein	E2
1. Log in to the Einstein.	1. Log in to the E2
2. Press F8, Y to access the System Configuration Menu .	2. Press the MENU  key.
3. Press 4 - Network Status/Setup .	3. Press & 7 to navigate to the System Configuration Menu .
4. Press 2 - Connected I/O Boards & Controllers .	4. Press & 7 to navigate to the Network Status/Setup menu.
5. Change the number of CUB boards in the CUB Controllers field to the correct number of boards.	5. Press @ 2 - Connected I/O Boards & Controllers.
	6. Change the number of CUB boards in the CUB Controllers field to the correct number of boards.

When CUBs are deleted in this way, E2 or Einstein will always delete the highest numbered CUBs first. Therefore, if you have seven CUBs (numbered 1-7) and you change the number of CUBs to five, the E2 or Einstein will delete board #6 and #7, leaving boards #1 through #5.

7.2 Viewing the CUB Status Screen

Once you have added a CUB to the E2 or Einstein, you will be able to see the status of the CUB board(s) from the front panel.

Einstein	E2
1. From the Main Status Screen, press F5 - MORE .	1. From the Main Status Screen, press the MENU  key and select & 5 - Configured Applications .
2. Press C - CUBs	2. Press & 7 to select "MultiFlex CUB" from the menu.
If multiple CUBs are associated with this Einstein, a list will appear prompting you to select a single CUB. Use the arrow keys to highlight the CUB you wish to view, and press ENTER .	
	If multiple CUBs are associated with this Einstein, the CUB Summary Screen will be shown. To see a single CUB's status screen, use the arrow keys to highlight the CUB you wish to view, and press Enter  .

The **CUB Status** Screen for the CUB you selected will appear (Figure 7-2).

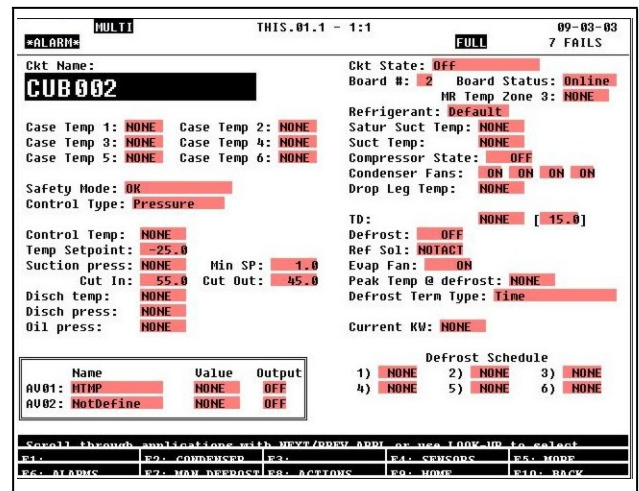

Figure 7-2 - CUB Status Screen

The **CUB Status** Screen shows the current status of all condensing unit systems. Though there is a large amount of information on a CUB status screen, status information is grouped on this screen in several groups of related information in order to make the screen easier to read. These groups are described below.

7.2.1 Inputs and Setpoints

All the major control inputs for a CUB and the control setpoints are grouped together in the left side column of the screen.

Case Temp 1-6

The **Case Temp** fields numbered **1 through 6** show the current value of the case discharge air temperature sensors. If unused, **NONE** will be displayed in the field instead of a temperature value.

Safety Mode

The **Safety Mode** field will display whether the board has any active alarms or failures. If the system is functioning normally, this field will show **OK**. If there is a failure, it will display one of the Safety mode messages. Refer to **Section 6.5, Alarm Conditions (Safety Modes)** for more information about Safety modes.

- **OK** - No Safety mode failures.
- **Phase Fail** - A phase loss has been detected and all systems have been shut down.
- **Oil Fail** - The compressor has failed due to low oil pressure.
- **Hi Disch Trip** - Discharge pressure rose higher than the discharge trip setpoint, causing refrigeration to shut down.
- **Proof Fail** - A compressor proof fail has occurred.
- **Door Open Time** - The door switch has been open for longer than the programmed alarm time.
- **Clean Time** - The clean switch has been ON for longer than the programmed alarm time.

Control Type

For reference, Control Type shows whether this CUB is controlling the compressor based on the suction pressure or case temperature.

Control Temp

If you are using the Temperature strategy to control the compressor, the Control Temp field will show the current temperature value. You can compare this value to the temperature setpoint below it to determine if the compressor is supposed to be ON or OFF.

Temp Setpoint

This field shows the current case temperature control setpoint, which is used in compressor control when using the Temperature strategy.

Suction press

This field shows the current suction pressure in the CUB. Note that if using the Pressure compressor control strategy, this is the control input for the compressor, which you can compare to the Cut In/Cut Out setpoints below it on the screen to determine if the compressor is supposed to be ON or OFF.

Min SP

This field shows the value of the Minimum Suction Pressure setpoint, which is used to shut the compressor OFF before the suction pressure can become too low. Min SP is used for Temperature Control or Pump Down.

Cut In and Cut Out

The Cut In/Cut Out setpoints are used to turn the compressor ON and OFF when the CUB is operating under the Pressure compressor control strategy. They are also used as fallback setpoints when the control temperature source fails under the Temperature strategy.

Disch temp

This field shows the current discharge temperature sensor if defined as one of the 16 CUB inputs.

Disch press

This field shows the current discharge pressure in the CUB.

Oil press

This field shows the current oil pressure in the CUB.

Defrost Term Temp

This field shows the current value of the defrost termination sensor in the CUB, which may be a digital value (ON/OFF) for a Klixon type sensor or a temperature value, depending on the selected defrost termination type.

7.2.2 Sensor Control

The input and output information for the CUB sensor control applications is shown in the box in the bottom left corner of the screen, labeled AV01 and AV02 on the left side of the screen. Each row consists of three fields showing (1) the name given to the sensor control application, (2) the current input value (shown in the engineering units programmed for the sensor control application), and (3) the current sensor control output state.

7.2.3 Outputs and Operational States

All the major control outputs for a CUB and information about case circuit and board online status are grouped together in the right side column of the screen.

Ckt State

Circuit State shows the current state of the circuit. The states that may appear here are:

- **Refrigeration** - The CUB is in Refrigeration mode.
- **Defrost** - Refrigeration is OFF and defrost is active in the circuit.
- **Off** - The refrigeration setpoint is satisfied and the CUB is not refrigerating.
- **Pump Down** - Is a transition state where the CUB is going from Refrigeration into Defrost or OFF, which allows refrigerant to be pumped out of the evaporator. Pump Down is an optional state. If enabled, the two types are **Idle Pump Down** and **Defrost Pump Down**.
- **Drip** - The CUB is in an inactive state immediately after Defrost that allows moisture to drip from the evaporator coils. Refrigeration will start immediately after the Drip stage is complete.
- **Cmp Delay** - The CUB is in a user-programmed delay period between the opening of the refrigeration solenoid and the activation of the compressor. This occurs when a CUB transitions from Off to Refrigeration.

Board

Indicates the number of the CUB board selected.

Board Status

This field shows the operational state of the CUB board itself. If everything is operating normally, this field will read **Online**.

MR Temp Zone 1-4

This field will show the temperature of the motor room zone this CUB is assigned to.

Refrigerant

For reference, this will show the type of refrigerant present in the condensing unit.

Sat Suct Temp

The saturation suction temperature is calculated automatically for this condensing unit based on the refrigerant type and the current suction pressure. The result of this calculation is shown in this field.

Suct Temp

The current temperature of the suction temperature sensor if defined as one of the 16 CUB inputs.

Compressor State

This field shows whether the compressor is ON or OFF.

Condenser Fans

These fields show the ON/OFF state of the condenser fan(s).

Drop Leg Temp

The current drop leg temperature used for TD control.

TD

The current value of the temperature differential (*drop leg temperature + drop leg offset - plenum temperature*).

Defrost

This field shows the ON/OFF state of the defrost output.

Refr Sol

This field shows the ON/OFF state of the refrigeration solenoid.

Evap Fan

This field shows the ON/OFF state of the case circuit fans.

7.2.4 Defrost

Information about defrost for the CUB case lineup is shown in the fields at the bottom right side of the screen.

Peak Temp @ defrost

This field shows the highest case temperature value recorded during the last defrost cycle.

Defrost Term Type

For reference, the Defrost Termination Type is displayed on this screen, showing the strategy that is being used to terminate defrost cycles. There are several possible values that can appear here:

- **Time** - Defrost always lasts the entire programmed defrost duration.
- **Digital** - A digital temperature sensor will close to terminate defrost.
- **Term Temp** - A dedicated analog temperature sensor is being used to measure termination temp and compare it to the programmed termination setpoint.
- **Min Case Temp** - The lowest of all available case temperature sensors is always used as the termination temperature for purposes of comparing it to the termination setpoint.
- **Suction Pressure** - Defrost terminates when the suction pressure rises above a programmed setpoint.
- **Case Temp 1-6** - One of the six possible case temperature inputs is being used as the termination temperature for purposes of comparing it to the termination setpoint. The number shown indicates which Case Temp input is being used.

Defrost Term...

This field will change based on what the Defrost Termination Type (**Term. Type** in the **Defrost Setup** screen) is set to:

- **Defr Term Act State:** appears when Defrost Term Type is set to Digital.
- **Blank:** the field is blank when Defrost Term Type is set to Time. Time will appear in the Defrost Term Type field.
- **Defr Term setpt:** appears when the Defrost Term Type is set to Suction Pressure. This field will contain the suction pressure termination setpoint in Pressure. During defrost, you can compare this setpoint to the Suction press input value in the left-hand column.
- **Defr Term Temp Setpt:** appears when any other Termination Type is selected (all other types are Temperature). Defrost Term Type will show the selected Temperature Termination Type.

Defrost Schedule

For reference, the Defrost Schedule programmed for this CUB is shown at the bottom of the right side column in this screen. The schedule shows the times during each day that a defrost cycle will begin.

7.2.5 KW Usage

If a KW transducer is being used to measure the condensing unit's power consumption, the KW consumption information measured by the CUB is shown in a pair of fields on the left side of the screen.

Current KW

This field shows the current reading of the KW transducer.

7.3 Programming The CUB Using the E2 or Einstein Front Panel

NOTE

If you are programming a CUB-TD from the E2 or Einstein front-panel interface, refer to **Configuring Setpoints in E2 or Einstein for CUB-TD on page 64 for setup instructions specific to CUB-TD.**

A CUB's setpoints can be viewed and changed via the E2 or Einstein front panel interface. Programming a CUB using E2 or Einstein is similar in form to programming any other E2 or Einstein application, except changes made to CUB configuration are made directly to the CUB board's programming, not to the E2 or Einstein's programming.

To begin programming a CUB, navigate to the CUB Status Screen for the board you wish to program (see **Section 7.2, Viewing the CUB Status Screen**). For Einstein, press **F7** followed by **B** to enter the **Setup Editor**. For E2, press **F5**.

7.3.1 Screen 1: General

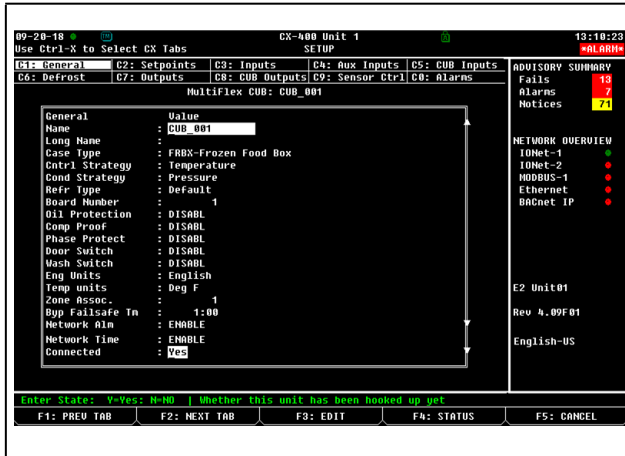

Figure 7-3 - Screen 1: General Screen

Name

Enter a name for this CUB in the Name field.

Long Name

If desired, enter a 63-character description of the CUB in the Long Name field.

Case Type

The Case Type field is used to assign default setpoints for your circuit based on the case type. There are 64 case types to choose from, each with its own default temperature setpoint, defrost type, and defrost times. A complete list of case types is provided in **Appendix B: Case Type Defaults on page 59**. Use the Look-Up Table (F7 for Einstein, F4 for E2) to select a case type.

Ctrl Strategy

Control Strategy determines whether the compressor will be controlled by suction pressure or suction temperature. Use the **Look-Up Table** (F7 for Einstein, F4 for E2) to select **Pressure** or **Temperature**.

Cond Strategy

The Condenser Strategy determines whether the condenser will be controlled by discharge pressure (Pressure) or by temperature differential strategy (TD). Use the **Look-Up Table** (F7 for Einstein, F4 for E2) to select a strategy.

Refr Type

The Refrigerant Type field is where the type of refrigerant being used in the condensing unit system must be specified. The CUB uses the Refrigerant Type field to automatically calculate saturation suction temperature. Use the Look-Up Table (F7 for Einstein, F4 for E2) to select a refrigerant type.

Oil Protection

If set to **ENABLE**, the Oil Protection field specifies whether an oil failure sensing device is present for the condensing unit. If an oil pressure transducer is available, set this field to **ENABLE**. If oil pressure checking will not be used for this CUB, set this field to **DISABLE**.

Comp Proof

The Comp Proof field specifies whether a compressor proof checking device is present for the condensing unit. If a compressor proof input is available, set this field to **ENABLE**. If compressor proof checking will not be used for this CUB, set this field to **DISABLE**.

Phase Protect

The Phase Protect field specifies whether a phase loss detection device is present for the condensing unit. If a phase loss input is present, set this field to **ENABLE**. If not, set this field to **DISABLE**.

Door Switch

The Door Switch field specifies whether a door switch is present on the condensing unit's case circuit. If a door switch input is available, set this field to **ENABLE**.

Board Number

Board Number is the address the board is set to.

Connected

The Connected field specifies whether the CUB board is connected. Once the CUB is physically connected, the user will be required to set this property to Yes for communication.

Unlike other MultiFlex devices, the CUB will not automatically communicate with the E2 once the board is properly numbered and added in the Connected I/O screen. To enable communication with the CUB, you must set the Connected parameter to **Yes** in the **General** tab of the **CUB Setup** screen. By default, this parameter is set to **No** when a new CUB is added to the E2.

Wash Switch

The Wash Switch field specifies whether this condensing unit has a clean switch to toggle the case circuit in and out of Wash mode. If a clean switch input is available, set this field to **ENABLE**.

Eng Units

Engineering Units determines whether engineering units for pressure values will be displayed using English units (pounds per square inch (PSI)) or metric units (kilopascals (KPA)).

Temp units

Temperature Units determines whether engineering units for temperature will be displayed in **degrees Fahrenheit** or **degrees Celsius**.

Zone Assoc.

Zone Association allows you to assign this CUB to a zone along with other CUBs in the same motor room. This will cause the motor room temperature to be displayed on the CUB-II's status screen in E2 or Einstein, and it also affects which of the "SPARE ANALOG OUT" Global Data inputs a motor room temperature sensor sends its value to (see **Section 6.4.2, Motor Room Temperature Control**, for an explanation of how this works).

Byp Failsafe Tm

Bypass failsafe time is the maximum amount of time the CUB will stay in Bypass mode (Ref Override On). This and any other bypass modes can be cancelled by issuing an End Manual mode.

Network Alm

This field specifies whether you want the CUB to set its alarm output if it goes offline.

Network Time

This field specifies whether you want the CUB to keep its own time clock synchronized with its parent controller's clock. Set this field to **ENABLE** if you want CUB to synchronize its time with E2 or Einstein, or **DISABLE** if you don't want time synchronization.

7.3.2 Screen 2: Setpoints

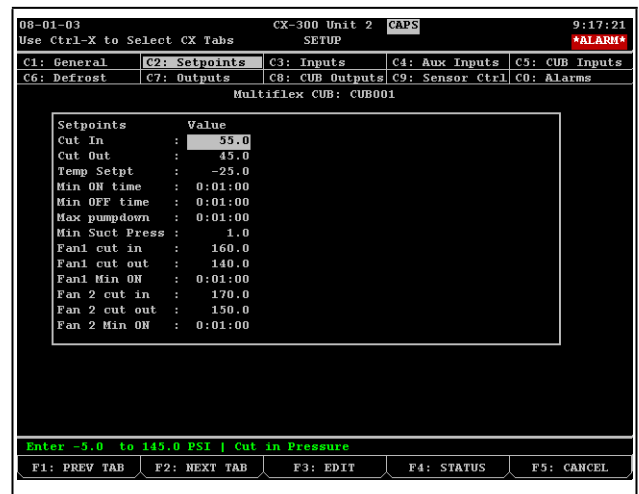

Figure 7-4 - Screen 2: Setpoints Screen

The Setpoints screen is where all setpoints related to compressor and condenser fan control are entered. The fields that appear on this screen depend largely on whether you set the **Control Strategy in Screen 1 (Section 7.3.1, Screen 1: General)** to **Pressure** or **Temperature** and whether you set the **Condenser Strategy** to **Pressure** or **TD**. The field descriptions below will indicate whether each field is visible for only the Pressure strategy, for only the Temperature strategy, or for both.

Cut In and Cut Out

If you are using the Pressure compressor control strategy, the Cut In setpoint determines the suction pressure that, when exceeded, will cause the compressor to turn ON. In this strategy, the compressor will remain ON until the pressure falls below the Cut Out setpoint, at which point the compressor will turn OFF.

If you are using the temperature compressor control strategy, these setpoints are used as a fall back if the MultiFlex CUB cannot determine the current case temperature. When this occurs, the suction pressure becomes the control input, and the CUB uses the Cut In and Cut Out setpoints to control the compressor.

Comb. method

The Comb. method field appears only for the temperature compressor control strategy.

The Combination Method determines how multiple case temperature sensors in the case circuit will be combined into a single control temperature value for use in comparing to the temperature setpoint. There are five strategies to choose from:

- **AVG** - The average value of all case temperature inputs.
- **MIN** - The lowest sensor value of all the case temperature inputs.
- **MAX** - The highest sensor value of all the case temperature inputs.
- **FIRST** - The lowest numbered temperature sensor that is reading a valid temperature.
- **MIX** - A mixture of the first two valid case temp sensor values. The percentage at which these two sensor values are mixed is determined by the Mix% field.

Case Temp Mix

Visible only when the Comb Method is set to MIX, the Case Temp Mix field is the percentage used to mix the values of Case Temp 1 and Case Temp 2. To mix the values, the CUB adds x% of Case Temp 1 to (100-x)% of Case Temp 2.

Temp Setpt

The temperature setpoint is the circuit temperature to which the CUB will attempt to control the cases. Along with the temperature deadband, the CUB uses this setpoint to determine when refrigeration is needed. Refer to **Section 6.1.2, Case Temperature Compressor Control**, for more on how the temperature setpoint works.

Temp Deadband

The temperature deadband is a range of temperatures equally above and below the setpoint within which the case circuit temperature is considered to be acceptable. While within this range, the compressor will remain in its current state until the temperature input value triggers a change by moving above or below the deadband range. Refer to **Section 6.1.2, Case Temperature Compressor Control**, for more on how the temperature setpoint works.

Min ON time

The Minimum ON Time is the amount of time the compressor must remain ON after activation before being allowed to turn OFF. Enter the desired minimum ON time in **hours:minutes:seconds (H:MM:SS)** format.

Min OFF time

The Minimum OFF Time is the amount of time the compressor must remain OFF after deactivation before being allowed to turn ON. Enter the desired minimum OFF time in **hours:minutes:seconds (H:MM:SS)** format.

Idle Pump Down

The Idle Pump Down field appears only if using the temperature compressor control strategy.

The Idle Pump Down field enables or disables the pump down delay that occurs in between refrigeration and idle (off). If set to **ENABLE**, the CUB will turn the refrigeration solenoid output OFF and leave the compressor ON until the suction pressure is below the Minimum Suction Pressure setpoint, or when Maximum Pump Down time expires. This effectively pumps refrigerant out of the coil.

If set to **DISABLE**, the CUB will transition from refrigeration to idle with no pump down cycle.

Max pumpdown

The Max Pump Down time is the maximum amount of time a Pump Down delay period will last if it is not terminated prematurely by the suction pressure falling below the Minimum Suction Pressure value.

Ref/Comp ON Delay

This field appears only if using the temperature compressor control strategy and only if Idle Pump Down is set to **ENABLE**.

The Ref/Compressor ON Delay affects how long the CUB will wait after opening the refrigeration solenoid at the start of refrigeration before activating the compressor. Enter the desired delay in **hours:minutes:seconds (H:MM:SS)** format.

Min Suct Press

The Minimum Suction Pressure setpoint serves two purposes. When the condensing unit is operating in Refrigeration mode using the Temperature strategy, the Minimum Suction Pressure is the suction pressure at which the compressor will be shut off regardless of the case circuit temperature. This setpoint is necessary as a safety feature since the CUB is controlling by temperature instead of by suction pressure.

If you enabled the Pump Down delay feature for this CUB, the Minimum Suction Pressure also acts as the termination setpoint for the pump down delay. The Pump Down delay period will end when the suction pressure falls below this setpoint.

7.3.2.1 Temperature Differential (TD)

TD setpoint

The temperature differential setpoint is the minimum allowable difference between the refrigerant drop leg temperature and the ambient (plenum) temperature. When the TD (i.e., *drop leg temp + drop leg offset - plenum temp*) begins to climb above this setpoint, fans will be cycled ON to bring down the drop leg temperature (thus lowering the TD measurement).

TD deadband

The temperature differential deadband is a range of values around the TD Setpoint within which the value of the TD calculation is acceptable. When the TD rises above the setpoint plus 1/2 the deadband value, fans will begin cycling ON. When the TD falls below the setpoint minus 1/2 the deadband value, fans will cycle OFF.

Drop Leg Max

The Drop Leg Max setpoint is the maximum allowable value of the drop leg temperature. If the drop leg temperature rises above this setpoint, the CUB will cycle condenser fans ON regardless of the value of the TD.

Drop Leg Min

The Drop Leg Min setpoint is the minimum allowable value of the drop leg temperature. If the drop leg temperature falls below this setpoint, the CUB will cycle condenser fans OFF regardless of the value of the TD.

Cond Fan On Dly

If using TD control, the CUB cycles fans ON when the TD is above the setpoint at the rate set in the **Cond Fan On Dly** field. In other words, if this field is set to 30 seconds, then the CUB-II will stage each fan ON in 30-second intervals until all fans are ON or until the TD falls back below the setpoint.

Cond Fan Of Dly

If using TD control, the CUB cycles fans OFF when the TD is below the setpoint at the rate set in the Cond Fan Of Dly field. In other words, if this field is set to 30 seconds, then the CUB will stage each fan OFF in 30-second intervals until all fans are OFF or until the TD rises back above the setpoint.

7.3.2.2 Traditional Strategy

Fan 1 Cut In

Fan 1 Cut In sets the activation setpoint for condenser fan #1. When the discharge pressure rises above the Cut In setpoint, the fan will turn ON.

Fan 1 Cut Out

Fan 1 Cut Out sets the deactivation setpoint for condenser fan #1. When the discharge pressure falls below the Cut Out setpoint, the fan will turn OFF.

Fan 1 Minimum ON Time

The Fan 1 Minimum ON time is the smallest amount of time condenser fan #1 must remain ON after being activated.

Fan 2 Cut In

Fan 2 Cut In sets the activation setpoint for condenser fan #2. When the discharge pressure rises above the Cut In setpoint, the fan will turn ON.

It is recommended you program this fan with a higher Cut In setpoint than condenser fan #1, so that this fan will come on as a second stage.

Fan 2 Cut Out

Fan 2 Cut Out sets the deactivation setpoint for condenser fan #2. When the discharge pressure falls below the Cut Out setpoint, the fan will turn OFF.

Fan 2 Minimum ON Time

The Fan 2 Minimum ON time is the smallest amount of time condenser fan #2 must remain ON after being activated.

7.3.3 Screen 3: Inputs

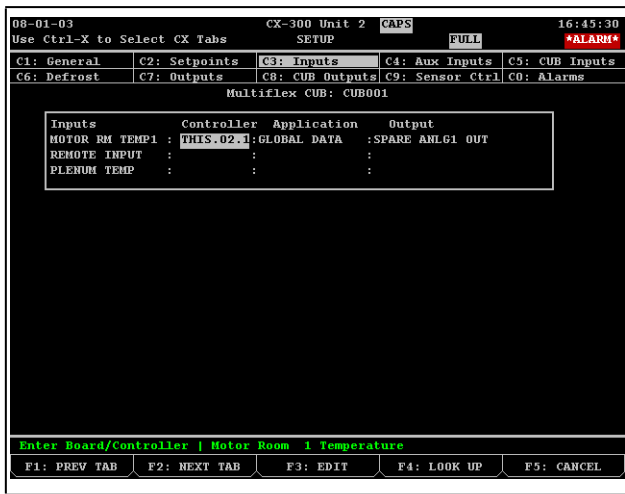

Figure 7-5 - Screen 3: Inputs Screen

The Inputs screen is where special data sharing connections between the CUB and E2 or Einstein must be set up for motor room control, outside air temperature sharing with Global Data, and reading remote inputs from the CUB board that may be read by other E2 or Einstein applications.

MOTOR RM TEMP

This input name will have a number after it from **1-4**, which is the same number as the motor room zone number you programmed for this **CUB in Screen 1**. This input reads from the parent E2 or Einstein's Global Data the value of the motor room temperature, provided there is a CUB in the zone with a motor room temperature sensor.

This input is automatically configured, and is primarily displayed in this screen as a reference.

REMOTE INPUT

The Remote Input is passed to any of the CUB's outputs that are set up as **"Remote"** type outputs. When this input is tied to a digital output from another E2 or Einstein application, it will cause all "Remote" outputs on the CUB board to mirror the digital state of the digital output.

Enter the controller, application, and property address of the remote input in this field.

PLENUM TEMP

The plenum temperature input provides the CUB the current value of the ambient temperature used for TD calculation.

Because plenum temperature will likely be measured by one temp sensor and will be shared with multiple CUB-IIs and CUB-TDs, it is recommended the plenum temperature sensor itself is physically connected to Global Data's Spare Analog inputs, and the plenum temperature input definition be set up to receive its value from Global Data. Refer to **Set Up Motor Room Temperature and Plenum Temperature Inputs on page 54** for special instructions on setting up plenum temperature in Global Data.

7.3.4 Screen 4: Aux Inputs

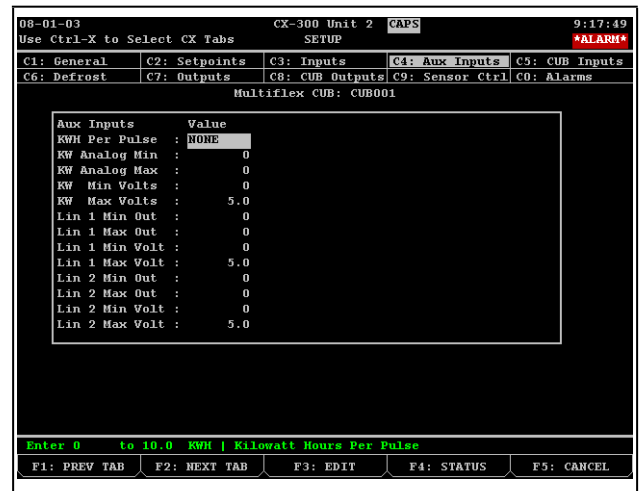

Figure 7-6 - Screen 4: Aux Inputs Screen

The Aux Inputs screen is used to set the characteristics of certain input types that may be required by the MultiFlex CUB.

Specifically, if you are using power transducers, you must enter information in this screen that helps the CUB translate the KW transducer signal into a KW value.

Also, if you are using a linear sensor type that is not supported by the CUB, you can assign it to one of the three spare Linear sensor types. You must enter the voltage and output ranges for each Linear sensor type if you wish to do this.

KWH Per Pulse

If you are using a pulse accumulation type KW transducer, you must enter the number of KWH per pulse for this transducer in this field. Otherwise, leave this field set to NONE.

KW Analog Min and Max / KW Min Volts and Max Volts

If you are using an analog KW transducer, you must enter the voltage range of the input and the range of KW values the voltage corresponds to. This information is different for each KW Transducer and depends on the line voltage and current transducer (CT) rating. Refer to your KW transducer's installation instructions.

Linear 1 and Linear 2 Fields

If you wish to use a sensor type not directly supported by the CUB, and the sensor type has an output voltage between 0 and 5 volts DC, you may assign this sensor one of the two Linear sensor types (Linear 1 and Linear 2). You may then connect the sensor to a point on the CUB and designate the point as sensor type **Linear 1** or **Linear 2** (see **Section 7.3.3, Screen 3: Inputs**).

To configure one of the Linear sensor types, you must enter values for each of the four fields:

- **Minimum Out** - The smallest possible value of the sensor's input value. Enter this number in the engineering units you will be using for this input.
- **Maximum Out** - The largest possible value of the sensor's input value. Enter this number in the engineering units you will be using for this input.
- **Minimum Volts** - The raw voltage value of the sensor that corresponds to the value you entered in the Min Out field.
- **Maximum Volts** - The raw voltage value of the sensor that corresponds to the value you entered in the Max Out field.

7.3.5 Screen 5: CUB Inputs

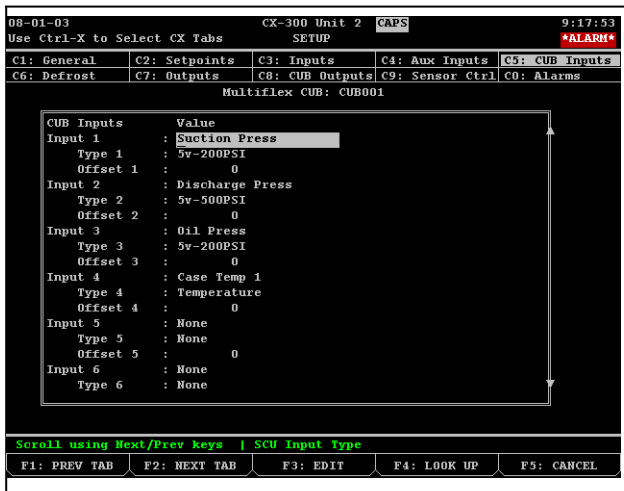

Figure 7-7 - Screen 5: CUB Inputs

The CUB Inputs screen is where you specify the type and functions of all the sensors, transducers, and contact closures connected to the MultiFlex CUB.

There are sixteen rows on this screen labeled from **#1 to #16**, corresponding to the input points on the MultiFlex CUB board. For each input that has an input device connected to it, configure the **Input**, **Type**, and **Offset** fields.

Input

The Input field is where you must specify the function of the input device attached to the point. With the cursor in this field, use the **Look-Up Table** (press **F7** for Einstein, **F4** for E2) to choose one of the inputs supported by the CUB.

Table 7-1 - MultiFlex CUB Input Names

Name	Description
Suct Press	Suction pressure transducer
Discharge Press	Discharge pressure transducer
Oil Press	Analog oil pressure transducer
Case 1 Temp-Case 6 Temp	Case temperature sensors #1 through #6
Dropleg Temp	Drop Leg Temp for TD condenser control
Defr Term Temp	Analog termination temperature sensor (NOT digital — use Defrost Term Sensor for digital sensors)
Defr Term Dig	Digital defrost termination sensor (NOT analog — Use Term Temp for analog termination sensors)
Alarm Reset	Alarm reset button or switch
Door Switch	Door switch
Clean Switch	Clean switch
Discharge Temp	Discharge temperature
Sensor Control 1-2	Input for Sensor Control modules #1 and #2
Compressor Proof	Compressor proof
Phase Loss	Phase loss checking device
KW	KW input (analog or digital)
Suction Temp	Suction Temperature Probe
Oil Digital	Digital oil failure pressure switch

You may choose to have multiple inputs assigned to the same Sensor Control module. These inputs will be combined by the CUB's sensor control application using the strategy chosen in Sensor Control.

Type

The Type field tells the CUB what kind of sensor is providing the input value. This value of this field must correspond to the type of input suggested by the Input field. For example, if the name of an input is Suct Temp, CaseTemp1, or one of the other analog temperature sensor types, the Type field must be set to Temperature in order for the input signal from the sensor to be read like a temperature sensor.

Note that when you choose a value for the Input field, the CUB does not automatically enter an appropriate default value in the Type field. You must manually enter the type for all sensor inputs.

Table 7-2 lists the input types that may be chosen in this field:

Table 7-2 - CUB Sensor Control Input Types

Input Type	Description
Temperature	Analog temperature sensor
12v-100PSI	12v transducer, 0-100PSI
12v-200PSI	12v transducer, 0-200PSI
12v-500PSI	12v transducer, 0-500PSI
5v-100PSI	5v transducer, 0-100PSI
5v-200PSI	5v transducer, 0-200PSI
5v-500PSI	5v transducer, 0-500PSI
Ref Leak	Refrigerant Leak Detector
Light Level	Light Level Sensor
Linear	0-5 V linear sensor
Humidity	Relative Humidity Sensor
KW Pulse	Kilowatt transducer, pulse KW output signal
KW Analog	Kilowatt transducer, 1-5VDC analog output signal
Dewpoint	Dewpoint Probe
LM235-TEMP	LM235 Temp Probe
Digital	Digital ON/OFF signal

To choose a sensor type, move the cursor into the Type field and use the **Look-Up Table** (press **F7** for Einstein, **F4** for E2).

Offset

The Offset field allows you to calibrate a sensor by adjusting the raw sensor value by a fixed amount. The value entered in the Offset field will always be added to the raw sensor value in the engineering units designated for that sensor.

An offset can also be used to subtract from a raw sensor value. To do this, enter a negative value in the **Offset** field.

7.3.6 Screen 6: Defrost

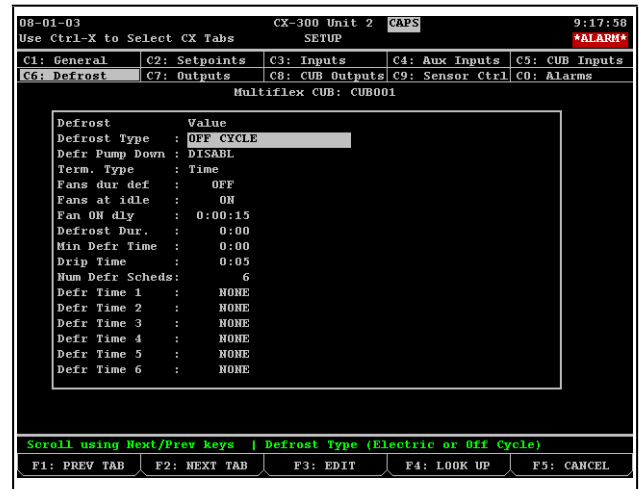

Figure 7-8 - Screen 6: Defrost Screen

Defrost Type

Choose the manner in which the case circuit will be defrosted in the **Defrost Type** field. There are two options:

- **Off Cycle** - Refrigeration will be disabled during defrost, and no heat will be directly applied to the evaporator.
- **Electric** - Refrigeration will be disabled during defrost, and electric heat will be applied to the evaporator.

Defr Pump Down

Enabling Defrost Pump Down causes the CUB to delay transition from Refrigeration to Defrost to allow refrigerant to be pumped out of the evaporator.

To enable the Pump Down Delay, set this field to **ENABLE**. To disable the Pump Down Delay, set this field to **DISABLE**.

Term. Type

The Termination Type determines which sensor's value will be used to determine when a defrost cycle must be terminated. There are six options:

- **Digital** - Digital temperature sensor (Klixon).
- **Term Temp** - Analog temperature sensor. Defrost will terminate when the temperature is above the termination temp setpoint.
- **Time** - Defrost will terminate when defrost time expires (this is the same as no termination).
- **Min Case Temp** - Instead of using a dedicated "Term Temp" sensor, the CUB will use the lowest value among all case temperature sensors as the defrost termination temperature value.
- **Suction Pressure** - The suction pressure transducer. Defrost will terminate when suction pressure rises above the termination pressure setpoint.
- **Case Temp 1-6** - Instead of using a dedicated "Term Temp" sensor, the CUB will use one of the six case temperature sensors as the termination sensor during defrost.

Suction Term

If you selected **Suction Pressure** as the **Termination Type**, the Suction Term field will appear on this screen. Enter the suction pressure that, when exceeded by the suction transducer, will cause defrost to terminate.

Fans dur def

Fans During Defrost determines the state of the case circuit evaporator fans when defrost is active for the circuit. Set this field to **ON** to turn the case fans ON during defrost, or **OFF** to turn the case fans OFF.

Fans at idle

This field determines the state of the case circuit evaporator fans when the case temperature setpoint is satisfied and refrigeration is not active in the case. Set this field to **ON** to leave the case fans ON during idle, or **OFF** to turn the case fans OFF.

Fan ON Dly

This parameter delays the amount of time the CUB will wait after a defrost has ended before turning on the evaporator fans. This delay is designed to keep the fans from blowing moisture off the coil and onto the case doors or walls. Enter the desired delay in **hours:minutes:seconds (H:MM:SS)**.

Defrost Dur.

The Defrost Duration is the maximum amount of time a defrost cycle will last. Unless it is prematurely terminated by temperature or suction pressure, a defrost cycle will end when it has been in defrost for an amount of time equal to this field (not including any pump down or drip delays).

Enter the desired Defrost Duration in **hours and minutes (HH:MM)**.

Min Defr Time

The Minimum Defrost Time sets the minimum amount of time a defrost cycle will last. A defrost cycle will always last at least as long as this time, and will ignore all calls for defrost to terminate until the Minimum Defrost Time has elapsed.

Enter the desired Defrost Duration in **hours and minutes (HH:MM)**.

Drip Time

The Drip Time is a delay between the end of defrost and the resuming of refrigeration to allow excess moisture to drain from the evaporator coil.

During the drip time, both the refrigeration and defrost outputs will be OFF. When the drip time has elapsed, refrigeration will resume in the case circuit.

Enter the desired drip time, in minutes, in this field.

Number of Defrost Schedules and Defrost Time

The Number of Defrost Schedules sets the number of daily defrosts for this circuit. This field is automatically filled in for you when you select a case type in the Case Type field.

Enter a number from **1 through 12** in this field. When you enter a number, the appropriate number of Defrost Time fields will appear under this field. Use these fields to enter the start times for each daily defrost cycle.

Defr Temp Setpt

If you selected **Term Temp**, **Min Case Temp**, or **Case Temp 1-6** as the **Termination Type**, the Defr Temp Setpt field will appear on this screen. Enter the case temperature that, when exceeded by the value of the termination sensor, will cause defrost to terminate.

7.3.7 Screen 7: Outputs

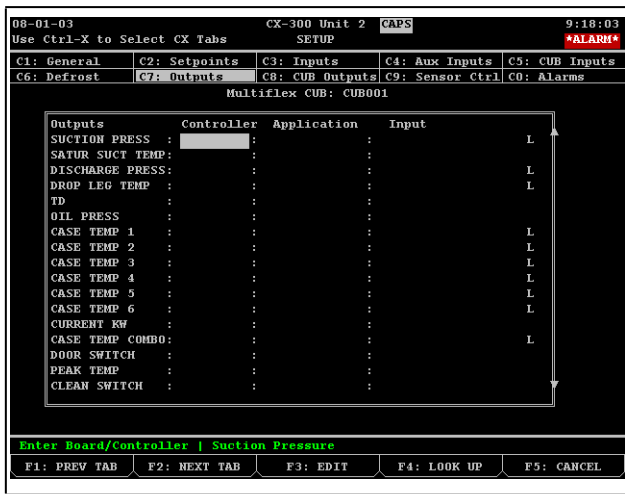

Figure 7-9 - Screen 7: Outputs Screen

Because the CUB has limited memory to log inputs and outputs, and because it has no ability to do customized advanced controls that may be required by certain sites, the E2 or Einstein makes all CUB input, output, and state values available as outputs. This allows you to log CUB inputs or outputs, to set up alarms for the CUB outside of its own alarm control capabilities, and to share CUB values with other E2 or Einstein applications.

You will not need to use this screen at all unless you are setting up advanced-level logging, alarming, or controls that involve the CUB inputs and outputs.

The descriptions below describe what the purpose of each output shown on this screen are. For each output definition, you may:

- **Share the value with another E2 or Einstein input** - Enter a controller/application/input address in the output definition, or press **F3, 1 - Alternate I/O Formats** to change the definition to a board/point or fixed value.
- **Set up logging or change logging parameters** - Move the cursor into the output definition, and navigate to the **Logging Setup** screen (**F8, 7** in Einstein, **F3, 5** in E2).
- **Set up generic alarming for a parameter** - Move the cursor into the output definition, and navigate to the **Generic Alarm Setup** screen (press **F8, 6** in Einstein, **F3, 4** in E2).

SUCTION PRESS

The current value of the CUB suction pressure input.

SATUR SUCT TEMP

The calculated value of the saturation suction temperature of the condensing unit system.

DISCHARGE PRESS

The current value of the CUB discharge pressure input.

DROP LEG TEMP

The current drop leg temperature used for TD Condenser Control.

TD

The current value of the temperature differential (*drop leg temperature + drop leg offset - plenum temperature*).

OIL PRESS

The current value of the CUB oil pressure input.

CKT STATE

The current CUB refrigeration state. The options are: Idle, Refrigeration, Defrost, Drip, Pump Down, Wash, Door, Fail, or Delay.

CASE TEMP 1 - 6

The six CASE TEMP outputs are equal to the values of each of the six possible CUB case temperature inputs. CASE TEMP 1 corresponds to CUB's case temp # 1, etc.

CURRENT KW

The current value of the CUB KW input.

BOARD STATUS

The online or offline network status of the CUB board.

CASE TEMP COMBO

The current combined value of all CUB case temperature inputs. This will be the same as CASE TEMP 1 if only one case temp sensor is present on the CUB.

DOOR SWITCH

The current ON/OFF state of the door switch.

PEAK TEMP

The highest case temperature recorded during the previous defrost cycle.

CLEAN SWITCH

The current ON/OFF state of the clean switch.

DISCH TEMP

The current value of the CUB discharge temperature.

AN SENS #1 and #2

The values of sensor control inputs #1 and #2. If a Sensor Control input on the CUB is set to OAT or motor room temp, this definition will be pre-defined to point to Global Data's OAT or SPARE ANLG 1-4 inputs. DO NOT change the values of these fields if they are already pointing to Global Data.

COMP PROOF

The current OK-FAIL state of the compressor proof.

PHASE LOSS

The current OK-FAIL state of the phase protection device.

SUCTION TEMP

The current value of the CUB's suction temperature sensor.

SAFETY MODE

When certain conditions are detected, the CUB and CUB-TD operate in a special mode called Safety mode. The options are: OK, PhaseFail, OilFail, HiDischTrip, ProofFail, DoorOpenTime, CleanTime.

CONTROL TYPE

The active compressor control type.

DIG OIL FAIL

The current value of the CUB's oil failure input.

COMPRESSOR

The current ON/OFF state of the compressor.

COND FAN 1 through COND FAN 4

The current ON/OFF state of condenser fans #1 through #4.

DEFR CONTACT

The current ON/OFF state of the CUB defrost output.

REFR SOL

The current ON/OFF state of the CUB refrigeration output (which drives the refrigeration solenoid).

EVAP FAN

The current ON/OFF state of the CUB evaporator fan output.

ALARM

The current ON/OFF state of the CUB alarm output.

SENS CTRL 1 and SENS CTRL 2

The current ON/OFF state of the digital outputs driven by the CUB sensor control applications.

REMOTE OUT

The current ON/OFF state of the CUB remote output.

7.3.8 Screen 8: CUB Outputs

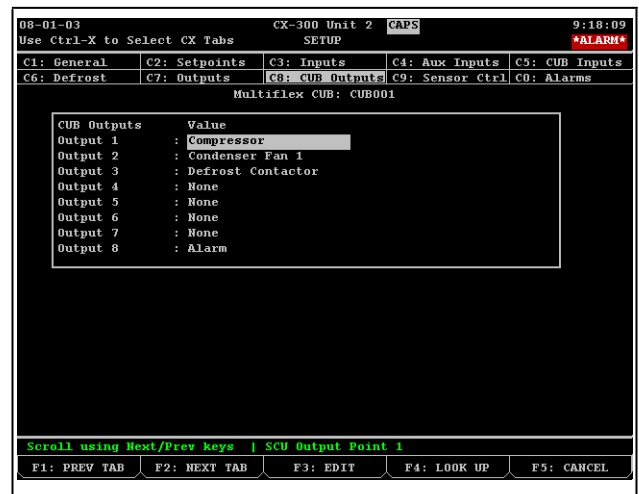

Figure 7-10 - Screen 8: CUB Outputs Screen

This screen configures the functions of the eight relay outputs on the MultiFlex CUB. By default, the compressor, defrost, condenser fan #1, and alarm outputs are pre-configured to points 1,2,3, and 8 respectively. You may assign other outputs to the remaining relay output points or change the default configuration using this screen.

The Outputs screen has eight numbered outputs corresponding to relays #1 through #8 on the CUB board. For each relay to be used by the CUB, you must choose the output type in the corresponding field.

The output choices are:

- **Compressor** - The condensing unit's compressor.
- **Condenser Fan #1** - The first condenser fan.
- **Condenser Fan #2** - The second condenser fan, if one is being used for the condensing unit.
- **Condenser Fan #3** - The third condenser fan, if one is being used for the condensing unit.
- **Condenser Fan #4** - The fourth condenser fan, if one is being used for the condensing unit.
- **Defrost Contactor** - The defrost output, which is activated when the case circuit is in defrost.
- **Refrigeration Sol.** - The condensing unit's refrigeration solenoid valve.
- **Evaporator Fan** - The fans in the case circuit.
- **Alarm** - The alarm output, which turns ON when an alarm is active in one or more CUB systems.
- **Sens Ctrl 1 - Sens Ctrl 2** - The two Sens Ctrl outputs for Sensor Control applications #1 and #2.
- **Remote Output** - A generic remote output type that may be addressed by an application in the CUB's parent E2 or Einstein.

7.3.9 Screen 9: Sensor Control

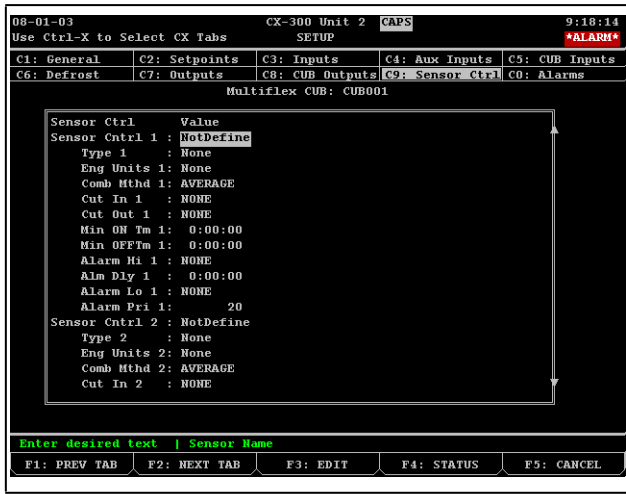

Figure 7-11 - Controller Setup Screen

This screen is where the MultiFlex CUB’s sensor control applications are programmed. Up to two sensor control applications may be programmed, each with its own set of inputs, setpoints, and outputs.

There are two headings for the fields on this screen, labeled **Sensor Cntrl 1** and **Sensor Cntrl 2**. The indented fields under each of these headings represents all the necessary fields for that sensor control application. Each of these field descriptions will have a 1 or a 2 at the end of their name to indicate whether the field applies to application #1 or #2.

Sensor Cntrl

Enter a name for the sensor control application in this field.

Type

The Type field tells the CUB if the sensor that is supplying the input for this sensor control application serves a special purpose or has special characteristics. This is not the same thing as Sensor Type, which is chosen by altering the Input Type in the Inputs screen (**Section 7.3.3, Screen 3: Inputs**).

Select one of the following types:

Input Type	Description
Generic	The sensor control application exists simply to control an output and to generate hi/lo alarms.
OAT	Choose this option if the input is reading outdoor air temperature. This will allow the CUB to share the OAT value with E2 or Einstein for use in other applications.
MotorRM T	Choose this option if the input is an air temperature sensor in the CUB’s motor room. This passes the sensor value to E2 or Einstein’s Global Data for sharing with other CUBs in the same zone.
Linear 1	The sensor connected to this input uses the linear properties for volts and engineering units specified in Screen 4, Auxiliary Inputs, for "Linear 1".
Linear 2	The sensor connected to this input uses the linear properties for volts and engineering units specified in Screen 4, Auxiliary Inputs, for "Linear 2".
Ref. Leak	The sensor is a refrigerant leak detector.
Light Level	The sensor is a light level sensor.

Comb Mthd

The Combination Method only applies if you assigned more than one input to this Sensor Control application. When multiple inputs are being used, they will be combined into a single input value using the method chosen in this field.

If you are not using more than one input, set the Comb Mthd field to None.

Cut In

The Cut In setpoint is the point at which the sensor control output will transition from OFF to ON. Refer to **Section 6.4.1, How Cut In/Cut Out Control Works**, for further explanation.

Cut Out

The Cut Out setpoint is the point at which the sensor control output will transition from ON to OFF. Refer to **Section 6.4.1, How Cut In/Cut Out Control Works**, for further explanation.

Min ON Tm

The Minimum ON Time is the amount of time this sensor control output must remain ON after activating before being allowed to turn OFF. Enter the desired time in **hours:minutes:seconds format (H:MM:SS)**.

Min OFF Tm

The Minimum OFF Time is the amount of time this sensor control output must remain OFF after deactivating before being allowed to turn ON. Enter the desired time in **hours:minutes:seconds format (H:MM:SS)**.

Alarm Hi

Alarm Hi sets the high alarm setpoint for this Sensor Control application. Whenever the sensor control input rises above the Alarm Hi setpoint, an alarm will be generated in the parent E2 or Einstein.

If you do not wish to generate a high alarm, leave this field set to **NONE**.

Alarm Hi Delay

Alarm Hi Delay is the amount of time the sensor control input must remain above the Alarm Hi setpoint before a high alarm will be generated. Enter the desired alarm delay in **hours:minutes:seconds (H:MM:SS)**.

Alarm Lo

Alarm Low sets the low alarm setpoint for this Sensor Control application. Whenever the sensor control input falls below the Alarm Lo setpoint, an alarm will be generated in the parent E2 or Einstein.

If you do not wish to generate a low alarm, leave this field set to **NONE**.

Alarm Lo Delay

Alarm Lo Delay is the amount of time the sensor control input must remain below the Alarm Lo setpoint before a low alarm will be generated. Enter the desired alarm delay in **hours:minutes:seconds (H:MM:SS)**.

Alarm Pri

Alarm Priority sets the alarm priority level of the high and low alarms generated for this sensor control application. The priority level is used to filter the alarm and determine how E2 or Einstein will react to and report the alarm.

Enter a priority level from **1 (highest) to 99 (lowest)** in this field. Typically, an alarm-level or failure-level advisory has a priority level of **20-30**, while a notice-level advisory has a priority level of **99**.

7.3.10 Screen 10: Alarms

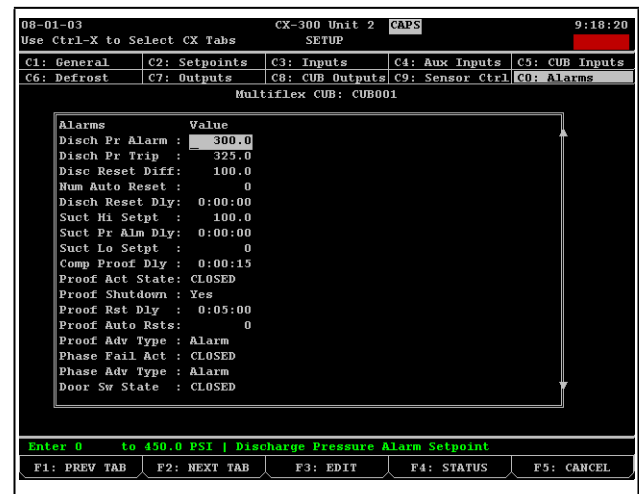

Figure 7-12 - Controller Setup Screen

This screen is where you configure the alarm setpoints for the pre-programmed alarm types supported by the CUB.

7.3.10.1 Oil Failure Alarm Setpoints

If Oil Protection is set to **ENABLE** under the **General Setup**, the MultiFlex CUB can generate an oil failure alarm when the compressor's oil pressure transducer registers low oil readings.

Oil Fail Type

Choose the type of input device used to check oil pressure on the condensing unit. Choose **Pressure** if using an analog pressure transducer, **Digital** if using a digital pressure switch, or **None** if you do not wish to generate oil failure alarms.

Oil Fail Setpt

If you chose **Pressure** as the **Oil Failure Type**, the **Oil Failure Setpoint** is the pressure that indicates a low oil condition in the compressor. When the oil pressure falls below this setpoint for **Oil Failure Delay**, a compressor oil failure alarm will be generated.

Oil Fail State

If you chose **Digital** as the **Oil Failure Type**, the **Oil Fail State** is the state of the digital pressure switch that indicates a low oil condition. When the digital input transitions to this state for **Oil Failure Delay**, a compressor oil failure alarm will be generated.

Oil Fail Delay

The Oil Failure Delay is the amount of time an analog oil pressure transducer must be below the setpoint, or a digital pressure switch must be in the fail state, before an alarm will be generated.

Analog Auto Rst

If you chose **Pressure** as the **Oil Failure Type**, the **Analog Auto Rst** field sets the number of times the CUB will attempt to reset the oil failure by turning the compressor **OFF** for the **Reset Delay**, and then **ON**. If the oil sensor still registers a failure after all retries have occurred, the CUB will consider the compressor failed and will not attempt another reset.

Enter a number of retries from **0-2**.

Dig. Auto Reset

If you chose **Digital** as the **Oil Failure Type**, the **Auto Resets** field sets the number of times the CUB will attempt to reset the oil failure by turning the compressor **OFF** for the **Reset Delay**, and then **ON**. If the oil switch still registers a failure after all retries have occurred, the CUB will consider the compressor failed and will not attempt another reset.

Enter a number of retries from **0-2**.

Reset Delay

The Reset Delay is the amount of time the CUB will wait between retry attempts. Enter the desired reset delay in **hours:minutes:seconds (H:MM:SS)** format.

Oil Xducer Run

This field determines whether the CUB will continue to attempt to control the compressor as normal even after an oil failure has occurred. If this field is set to **Yes**, the CUB will turn the compressor output ON and OFF as normal during an oil failure. If set to **No**, the CUB will attempt the auto resets described above. If after the auto resets the compressor has an oil failure, a reset from the E2 or Einstein or CUB will be required to clear the oil failure.

7.3.10.2 Discharge Pressure Alarm

The CUB can be programmed with up to two levels of discharge pressure alarm notification. A Discharge Pressure Alarm setpoint may be programmed to generate an alarm when the pressure rises too high. A Discharge Trip Setpoint may also be programmed to shut down the compressor when the discharge pressure reaches unsafe levels.

Disch Pr Alarm

Enter the discharge pressure level that, when exceeded, will cause a discharge pressure alarm to occur.

Disch Pr Trip

Enter the discharge pressure level that, when exceeded, will cause a system shutdown. The **Discharge Trip** setpoint should be higher than the **Discharge Pressure Alarm** setpoint.

Disc Reset Diff

A condensing unit that has been shut down due to Discharge Trip can be automatically reset. The Discharge Auto Reset is the pressure level the discharge pressure must fall to in order for the CUB to attempt a reset. When the pressure reaches this setpoint, the CUB will restart the system.

Num Auto Reset

The Num Auto Reset field sets the number of attempts the CUB will make to automatically reset the system after a discharge trip shutdown has occurred. After all attempts have been made and the discharge trip is still occurring, the CUB will lock the compressor OFF until the system is manually reset.

Enter a number of retries from **0-2**.

Disch Reset Dly

The Reset Delay is the amount of time the CUB will wait in between restarts to try to reset the discharge trip condition. Enter the desired delay in **hours:minutes:seconds (H:MM:SS)** format.

7.3.10.3 High/Low Suction Pressure Alarms

The MultiFlex CUB can be programmed to generate alarms when the suction pressure rises too high or falls too low.

Suct Hi Setpt

The Suct Hi Setpoint alarm setpoint is the suction pressure level that, when exceeded, will generate a suction pressure alarm. Enter the desired pressure in this field.

NOTE

This alarm will not be generated when the system is in defrost.

Suct Pr Alm Dly

The High Suction Pressure Alarm Delay is the amount of time the suction pressure must remain above the high suction pressure alarm setpoint before an alarm will be generated. Enter the desired delay in **hours:minutes:seconds (H:MM:SS)** format.

Suct Lo Setpt

The Suct Lo Setpt alarm setpoint is the level the suction pressure must fall below before a low suction pressure alarm will be generated. Enter the desired pressure in this field.

NOTE

This alarm will not be generated when the system is in Pump Down mode.

7.3.10.4 Compressor Proof Alarms

If a digital compressor proof checking device is available, the CUB can alarm on compressor failure and attempt to auto-reset the compressor.

Comp Proof Dly

The Compressor Proof Delay is the amount of time a proof checking device must read FAIL before the CUB will consider the compressor to have failed. Enter the desired delay in **hours:minutes:seconds (H:MM:SS)** format.

Proof Act State

The Proof Act State field tells the CUB what digital state from the proof checking device means **FAIL**. If set to **CLOSED**, the CUB will interpret a contact closure as **FAIL**. If set to **OPEN**, the CUB will interpret an open contact as **FAIL**.

Proof Shutdown

When the compressor fails, you have the option of either having the CUB control the compressor output as normal OR having the CUB lock the compressor OFF until the failure is reset. Set this field to **YES** if you want to lock the compressor OFF during failure. Set this field to **NO** if you want the CUB to continue attempting to control the compressor as normal.

Proof Rst Delay

The Proof Reset Delay is the amount of time the CUB will wait between retry attempts. Enter the number of seconds, from **0 to 240**, in this field.

Proof Auto Rsts

Proof Auto Resets determines how many times the CUB will attempt to automatically reset the compressor failure. After the retries have occurred, if the compressor is still failed, the CUB will consider the compressor failed until the compressor is reset manually.

Enter the desired number of resets in this field.

Proof Adv Type

The Proof Advisory Type allows you to set the kind of advisory generated when a compressor proof has failed. Choose **Alarm** if you want to generate an alarm, or **Notice** if you want to generate a notice.

7.3.10.5 Phase Fail Shutdown

If a phase loss detection device is available, the CUB can shut down all systems when a phase loss is detected.

Phase Fail Act

The Phase Fail Active State tells the CUB what digital state from the phase loss checking device signifies a phase failure. Set this field to **CLOSED** if the phase loss device closes its contacts on a phase failure, or **OPEN** if it opens contacts.

Phase Adv Type

When a phase loss occurs, the CUB will generate either an alarm or a notice, depending on the value of this field.

7.3.10.6 Door Switch Alarms

If a door switch is available, the CUB can be programmed to generate alarms to indicate an open freezer door.

Door Sw State

The Door Switch Active State specifies whether an open door causes the door switch to be **OPEN** or **CLOSED**. Choose the door switch state that corresponds to “**door open**” in this field.

Door Sw Time

After the door has been opened, the CUB records how long the door remains open. If it remains open longer than the Door Switch Time, the CUB will assume the door is stuck open and will restart refrigeration to prevent food loss. Enter the desired fail-safe time in **hours:minutes (H:MM)** format.

Door Sw Alm Tm

After the door has been opened, the CUB records how long the door remains open. If it remains open longer than the Door Switch Alarm Time, the CUB will generate a door open alarm. Enter the desired alarm setpoint in **hours:minutes (H:MM)** format.

7.3.10.7 Wash Active Alarms

If a clean switch is present on the condensing unit’s case circuit, you can program the CUB to generate an alarm if the system has been in Wash mode for too long.

Wash Sw State

The Wash Switch Active State specifies whether an OPEN or a CLOSED contact on the clean switch indicates “**enter wash mode**.” Choose either **OPEN** or **CLOSED** in this field.

Wash Sw Time

The Wash Switch Fail-Safe Time allows you to suspend Wash mode and resume refrigeration if Wash mode lasts longer than a fixed amount of time. Enter the desired **Wash Fail-Safe time in hours:minutes (H:MM)** format, or **0:00** if you do not wish to use this feature.

7.3.10.8 Case Temperature Alarms

The CUB will generate alarms when the case temperature is too high or too low.

Case Temp High

The Case Temp High Setpoint is the temperature at which a high case temperature alarm will be generated.

Case Tmp Dly

The Case Temp High Setpoint Delay is the amount of time the case temperature must be above the high case temp setpoint before an alarm will be generated.

Case Defr Dly

Because the case temperature can be considerably higher in a case that is exiting defrost, the Delay After Defrost allows you to prevent high case temp alarms from occurring for a fixed amount of time after the end of a defrost cycle. Enter the desired delay in **hours:minutes (H:MM)** format.

Case Temp Low

The Case Temp Low Setpoint is the temperature at which a low case temperature alarm will be generated.

Case Temp Low

The Case Temp Low Delay is the amount of time the case temperature must be below the low case temp setpoint before an alarm will be generated.

7.3.10.9 Suction Temperature Alarms

The CUB is capable of calculating suction temperature based on the suction pressure and refrigerant type. You may program the CUB to generate an alarm for high and low suction temperature values.

Suct Temp High

The Suction Temp High Setpoint is the suction temperature that, when exceeded, will cause a high suction temperature alarm to be generated.

Suct Tmp Dly

The Suction Temp High Delay is the amount of time the suction temperature must be above the Suction Temp High Setpoint before an alarm will be generated. The Suction Temp Low Delay is the amount of time the suction temperature must be below the Suction Temp Low Setpoint before an alarm will be generated. Enter the desired delay in **hours:minutes (H:MM)** format.

Suct Temp Low

The Suction Temp Low Setpoint is the suction temperature that, when fallen below, will cause a low suction temperature alarm to be generated.

7.3.10.10 TD Condenser Control Alarms

Drop Leg High

The Drop Leg High alarm setpoint is the drop leg temperature that, if exceeded, will cause an alarm to be generated. If you wish to generate an alarm for high drop leg temperature, enter the desired setpoint in this field. Otherwise, to disable this alarm, leave the value set to **NONE**.

Drop Leg Dly

If you are using the high drop leg temperature alarming feature, enter the amount of time the drop leg temperature must be higher than the setpoint before an alarm will be generated (**HHH:MM**).

TD High

The TD alarm setpoint is the value of the TD calculation that, if exceeded, will cause an alarm to be generated. If you wish to generate an alarm for high TD, enter the desired setpoint in this field. Otherwise, to disable this alarm, leave the value set to **NONE**.

TD Dly

If you are using the TD alarming feature, enter the amount of time the TD must be higher than the setpoint before an alarm will be generated (**HHH:MM**).

8 The MultiFlex CUB Hand-Held Interface

The MultiFlex CUB Hand-Held Terminal (HHT) interface allows you to view status of condensing unit systems and configure setpoints directly on the board. If you are using CUBs separate from a central E2 or Einstein system, the Hand-Held Terminal will be the only programming interface you may use.

IMPORTANT! If the CUB boards are connected to a parent E2 or Einstein, do not use the Hand-Held Terminal to make permanent configuration changes. Changes made to an E2- or Einstein-connected CUB via the Hand-Held Terminal are designed to be temporary. The parent controller does not recognize any configuration changes made by the HHT, and when the HHT is unplugged from the CUB, E2 or Einstein will change all parameters changed with the HHT back to their original values.

Table 8-1 - HHT Key Functions

HHT Keys	Function
F1	Main Menu screen
F2	Automatic scrolling status screen
LEFT ARROW and RIGHT ARROW	Left and right arrow keys point to the desired editable field
UP ARROW and DOWN ARROW	Up and down arrow keys scroll through screens
Cancel	Deletes number entered
Enter	Saves changes (optional - use the down arrow)
-	The Dash key toggles through the options of the list field
.	The Point key toggles through the options of the list field

8.1 CUB Hand-Held Terminal Status Screens

When you first plug in a Hand-Held Terminal into the MultiFlex CUB's HHT jack, the display will show the first of six status screens. The display will automatically scroll through each of the six screens in order at the rate of three seconds per screen. To toggle automatic scrolling **OFF** and **ON**, press the **Point "."** key on the Hand-Held Terminal.

You may also scroll through the status screens manually using the **UP ARROW** and **DOWN ARROW** keys.

8.1.1 Pressure Status

Pressure(hold=.)	
Suction	16.
Net Oil	111
Discharge	141

The Pressure Status screen shows the values of the suction pressure, oil pressure, and discharge pressure transducers.

8.1.2 Case Temp Status

CaseTemps	
1)36.6	2)36.5
3)36.6	4)35.9
5)36.5	6)36.6

The Case Temp Status screen shows the current values of all six case temperature inputs.

8.1.3 Other Temperatures

Temps	OAT: 32
Motor	Room: 32
Suc:21	SST: 120
Disch	Temp: NDF

This screen shows the value of the Outdoor Air Temperature and motor room temperature (both of which are read from E2 or Einstein's Global Data application), the Suction Temperature (Suc), the Suction Saturation Temperature (SST), and the Discharge Temperature (Disch Temp).

8.1.4 Input Summary Screen

```

Inputs
TermTemp: NDF
TermDig: OFF
SC1 117 SC2 -12

```

The Input Summary screen shows the status of the termination temperature sensor and the defrost digital termination input.

The Input Summary screen also shows the values of the sensor control inputs (SC1 and SC2) in the engineering unit value specified for the sensor control application.

8.1.5 Outputs Summary Screen #1

```

Outputs
Comp ON Def OFF
RSol ON
EvpfnON

```

The **Output Summary** screen shows the status of the compressor (Comp), defrost output (Def), refrigeration solenoid (RSol), and evaporator fan (Evpfn). Values shown in these fields will be either **ON** or **OFF**.

8.1.6 Outputs Summary Screen #2

```

Outputs
Cond1 ON #2 ON
Alarm OFF
SC1 OFF SC2 OFF

```

The **Output Summary** screen #2 shows the status of the condenser fans (Cond1 and #2), alarm output (Alarm), and the two sensor control outputs (SC1 and SC2). Values shown in these fields will be either **ON** or **OFF**.

8.1.7 System Status

```

Time: 12:00:00
Safety [Modes]
: OK
Circuit: Refr

```

This screen shows the current time, the currently active Safety mode, and the status of the refrigeration circuit.

8.1.8 Refrigeration Control Status

```

ControlBy: Temp
CI/CO SP/DB
55 /45 55 /5
P:32.5 T: 33.5

```

This screen shows the setpoints and control values for refrigeration control using both the Pressure and the Temperature control strategies.

If you are controlling by **Pressure (ControlBy: Press)**, the values under CI/CO are the Cut In/Cut Out suction pressure setpoints, and the value in the **P:** field is the suction pressure.

If you are controlling by **Temperature (ControlBy: Temp)**, the values under SP/DB are the setpoint and deadband values for the case temperature, and the value in the **T:** field is the combined case temperature for the circuit.

8.2 Altering CUB Configuration Using The Hand-Held Terminal

8.2.1 The Main Configuration Menu

To begin editing the MultiFlex CUB's configuration, press **F1** on the Hand-Held Terminal. This brings up the **Main Configuration Menu**.

```

1-Gen 2-Setpts
3-Alm 4-Defrst
5-Input 6-More
Select: 1
-----
7-Output
8- AuxIn
9-Sensor Control
Select: 7

```

NOTE

Pressing F1 at any time will bring up this menu screen.

The Main Menu is actually a series of two menus. Because of the limitation of the size of the screen, menu options **#7, 8, and 9** are only available after pressing **6-MORE**.

All of the screens that contain editable fields are categorized into one of the following menu options:

- **1 - General** - These screens set general properties for the condensing unit system, such as case circuit type and refrigerant type.
- **2 - Setpts** - These screens are where compressor, case circuit, and condenser control setpoints are specified.
- **3 - Alm** - Alarm setpoints and delays for all systems are configured in these screens.
- **4 - Defrost** - Fields in these screens are used to set defrost type, duration, termination setpoints, and other vital defrost control settings.
- **5 - Input** - These screens are used to configure the input names, types, and offsets for the MultiFlex CUB inputs.
- **7 - Output** (press **6-MORE** to access) - These screens are used to configure the output names for the MultiFlex CUB outputs.
- **8 - Aux In** (press **6-MORE** to access) - Special auxiliary input types are configured in these screens.
- **9 - Sensor Control** (press **6-MORE** to access) - All settings and setpoints necessary to set up sensor control applications in the CUB are configured in these screens.

8.2.2 Navigation

The screens underneath each menu item are a simple series of screens. The **UP ARROW** and **DOWN ARROW** keys are used to scroll through the screens.

Configuration Mode

On any menu or configuration screen, to make a selection or enter a value you must press the **RIGHT ARROW** key to begin Configuration mode.

In **Configuration** mode, you will see a cursor shaped like an arrow pointing right. Use the **UP ARROW** and **DOWN ARROW** keys to move the cursor to the field you want to change. Then, use the number keys to enter a value, or if the field requires a selection from a list of options, use the **Point key "."** and **Dash key "-"** to cycle through the options.

To enter alphanumeric information (such as names), use the **Point key "."** and the **Dash key "-"** to scroll through the characters for each space, and the **RIGHT ARROW** key to move to the next character.

To record your changes, simply press the **UP ARROW** or **DOWN ARROW** key to move the cursor to another field.

To exit **Configuration** mode, use the **UP ARROW** or **DOWN ARROW** keys to move the cursor off the screen. When it is no longer visible, you are no longer in Configuration mode and may navigate normally.

8.2.3 General Hand-Held Terminal Screens

The screens shown in this section are accessible by selecting 1-Gen from the Main Menu.

8.2.3.1 Circuit Name

```
Circuit Name
:UNDEFINED

CtrlStrat : Press
```

Circuit Name

If desired, enter a unique name for the circuit in this field. Use the **Point key "."** and **Dash key "-"** to scroll through alphanumeric characters for each space, and the **RIGHT ARROW** and **LEFT ARROW** keys to move the cursor to the next or previous character.

Control Strategy

The Control Strategy determines whether the compressor will be controlled by suction pressure or suction temperature. Select either **Pressure** or **Temperature**.

8.2.3.2 Refrigerant Select

```
Refrigerant:R401B
Case Type : 00
Oil Protect: NO
Comp Prf: YES
```

Refrigerant Type

The **Refrigerant** field is where the type of refrigerant being used in the condensing unit system must be specified. The E2 or Einstein uses the Refrigerant field to automatically calculate saturation suction temperature.

Case Type

The E2 or Einstein uses the **Case Type** field to assign default setpoints for your circuit based on the case type. There are **64 case types** to choose from, each with its own default temperature setpoint, defrost type, and defrost times. A complete list of case types is provided in **Appendix B: Case Type Defaults on page 59**.

Entering the case type number with the HHT is for reference purposes only. Setting the case type number will not set defaults for case setpoint or defrost. E2 or Einstein will override any settings made with the HHT.

Oil Protection

The **Oil Protect** field specifies whether an oil failure sensing device is present for the condensing unit. If an oil pressure transducer or digital input is available, set this field to **YES**. If oil pressure checking will not be used for this CUB, set this field to **NO**.

Compressor Proof

The **Comp Prf** field specifies whether a compressor proof checking device is present for the condensing unit. If a compressor proof input is available, set this field to **YES**. If compressor proof checking will not be used for this CUB, set this field to **NO**.

8.2.3.3 Phase

```
PhaseEnable: NO
Door Switch: YES
Wash Switch: NO
Pumpdwn: Disable
```

Phase Enable

The **PhaseEnable** field specifies whether a phase loss detection device is present for the condensing unit. If a phase loss input is present, set this field to **YES**. If not, set this field to **NO**.

Door Switch

The **Door Switch** field specifies whether a door switch is present on the condensing unit's case circuit. If a door switch input is available, set this field to **YES**.

Wash Switch

The **Wash Switch** field specifies whether this condensing unit has a clean switch to toggle the case circuit in and out of Wash mode. If a clean switch input is available, set this field to **YES**.

Pump Down

The **Pumpdwn** field enables or disables the **Pump Down Delay** that occurs in between refrigeration and defrost. If set to **YES**, the CUB will leave the **defrost output OFF** and leave the **compressor ON** until the suction pressure is below the Minimum Suction Pressure setpoint. If set to **NO**, there will be no delay between the end of refrigeration and the activation of the defrost output.

8.2.3.4 Temp EU

```
EngUnit: English
TempUnits: Deg C
Zone: 1
```

Engineering Units

The **EngUnit** field determines whether engineering units for pressure values will be displayed using **English units** (PSI, or pounds per square inch) or **metric units** (KPA, or kilopascals).

Temperature Units

The **TempUnits** field determines whether engineering units for temperature will be displayed in **degrees Fahrenheit** or **degrees Celsius**.

Zone

The **Zone** field allows you to assign this CUB to a zone along with other CUBs in the same motor room for purposes of controlling motor room temperature.

8.2.3.5 Time and Date

```
NetwrkAlarm: NO
NetworkTime: YES
Time: 15:00:04
Date: 01/04/02
```

Network Alarm

This field specifies whether you want the CUB to set its alarm output if it goes offline.

Network Time

This field specifies whether you want the CUB to keep its own time clock synchronized with its parent E2 or Einstein's clock. Set this field to **ENABLE** if you want CUB to synchronize its time with E2 or Einstein, or **DISABLE** if you don't want time synchronization.

Time

The Time field sets the time clock for the MultiFlex CUB. Enter the current time in **24-hour format (HH:MM:SS)**.

Date

The Date field sets the date for the MultiFlex CUB. Enter the current date in **MM/DD/YY** format.

8.2.3.6 Daylight Savings Time

Daylight Savings
APR NO DLT SUN
DLT Savings End
OCT NO DLT SUN

Daylight Savings

The three fields under the Daylight Savings heading determine which day of the year the MultiFlex CUB's internal clock will adjust the time to observe daylight savings time. The three fields, in order are:

- **MONTH** - The month in which daylight savings time begins. This should be set to APR (April) if following standard U.S. DST guidelines.
- **WEEK** - The week in which daylight savings time begins. This should be set to "1st Week" if following standard U.S. DST guidelines, or "NO DLT" if you do not wish to follow daylight savings time.
- **DAY** - The day of the week in which daylight savings time begins. This should be set to SUN (Sunday) if following standard U.S. DST guidelines.

Daylight Savings End

Like the Daylight Savings fields described above, the three fields under DLT Savings End determine the month, week, and day that daylight savings time ends for the MultiFlex CUB's internal clock.

If you wish to follow U.S. DST guidelines, set these three fields to **OCT**, **5th Week**, and **SUN** respectively. To disable **DST**, set the **Week** field to **NO DLT**.

8.2.4 Setpoints Screens

NOTE The following screens are only for CUB TD and CUB-II with TD Strategy. CUB TD consists of the next three screens (Condenser SPs, TD Strat Info, and TD Max).

For CUB temperature differential (TD), the Strategy is fixed as TD. The CUB Strategy can be set as TD or Traditional. For more information on TD Strategy, see **Section 6.2.1, Temperature Differential (TD) Strategy**.

See **Section 8.2.4.4, Comb Method** for the start of the HHT screen list for CUB.

8.2.4.1 Condenser Setpoints

Condenser SPs
Strategy: TD
Num Fans: 4

Condenser Setpoints

The two fields on this screen show the strategy being used and the number of condenser fans being controlled.

Strategy

The control strategy is fixed to **TD** for **CUB-TD**. For CUB using Traditional (Pressure) strategy, refer to **Section 8.2.4.6, Condenser SPs**.

Number of Fans

Set the number of condenser fans to be controlled by the TD Strategy (four maximum).

8.2.4.2 TD Strat Info

TD Strat Info
Dleg Min: 70
Dleg Max: 100
Dleg Off: 0

TD Strategy Information

The three fields under the TD Strat Info heading show the minimum and maximum setpoints of the drop leg temperature.

Drop Leg Minimum

If the drop leg temperature falls below this setpoint, the fans will stage OFF using FanOffDly.

Drop Leg Maximum

If the drop leg temperature rises above this setpoint, the fans will stage ON using FanOnDly.

Drop Leg Offset

A way of adding or subtracting an offset to the drop leg temperature sensor reading, if needed to tune the individual condensing unit.

8.2.4.3 TD Max

TD Max:	15
TD DBand:	1
FanOnDly:	30S
FanOffDly:	30S

TD Maximum

The TD setpoint that is maintained by cycling fans ON and OFF.

TD Deadband

The deadband forms a range of TD values equally above and below the setpoint within which the control TD value is considered to be within limits.

Fan On Delay

This setpoint defines the amount of time (in seconds) that must elapse between activation of fan stages.

Fan Off Delay

This setpoint defines the amount of time (in seconds) that must elapse between deactivation of fan stages.

NOTE

The following screens are only for CUB-II.

8.2.4.4 Comb Method

CombMeth:	Avg
Temp SetPt:	-12
Temp DdBnd:	5
Mix %:	50%

Combination Method

The CombMeth field is significant only if you are using the Temperature compressor control strategy.

The Combination Method determines how multiple case temperature sensors in the case circuit will be combined into a single control temperature value for use in comparing to the temperature setpoint. There are five strategies to choose from:

- **AVG** - The average value of all case temperature inputs.
- **MIN** - The lowest sensor value of all the case temperature inputs.
- **MAX** - The highest sensor value of all the case temperature inputs.
- **MIX** - A mixture of two inputs, the ratio of which is determined by the Mix % field (see **Mix Percentage** below).

- **FIRST** - The lowest-numbered input that is not shorted, open, or otherwise invalid, will be used as the case temperature input.

Temperature Setpoint

This field is significant only when using the Temperature compressor control strategy.

The temperature setpoint is the circuit temperature to which the CUB will attempt to control the cases. Along with the Temperature deadband, the CUB uses this setpoint to determine when to activate the compressor and when to deactivate it. Refer to **Section 6.1.2, Case Temperature Compressor Control**, for more on how the temperature setpoint works.

Temperature Deadband

This field is significant only when using the Temperature compressor control strategy.

The temperature deadband is a range of temperatures equally above and below the setpoint within which the case circuit temperature is considered to be acceptable. While within this range, the compressor will remain in its current state until the temperature input value triggers a change by moving above or below the deadband range. Refer to **Section 6.1.2, Case Temperature Compressor Control**, for more on how the temperature setpoint works.

Mix Percentage

The Mix % field is significant only if you have selected Mix in the Combination Method field. This field determines what mix ratio will be used to combine temperature input #1 with input #2. The Mix strategy adds x% of #1 to (100-x)% of #2 to yield the combined temperature, where x is the value entered in this field.

8.2.4.5 Min OFF/ON Times

MinOnTime :	1	M
MinOffTime:	1	M
Max Pmpdwn:	60	S
RsolCmpDly:	60	S

Minimum ON Time

The Minimum ON Time is the amount of time the compressor must remain ON after activation before being allowed to turn OFF. Enter the desired minimum ON time in minutes.

Minimum OFF Time

The Minimum OFF Time is the amount of time the compressor must remain OFF after deactivation before being allowed to turn ON. Enter the desired minimum OFF time in minutes.

Max Pump Down Time

A Pump Down is achieved by turning the refrigeration solenoid OFF while the compressor remains ON. The Max Pump Down Time is the maximum amount of time a Pump Down will last if it is not terminated prematurely by the suction pressure falling below the Minimum Suction Pressure setpoint.

Refrigeration Solenoid/Compressor ON Delay

This field appears only if using the Temperature compressor control strategy.

The Refrigeration Solenoid/Compressor ON Delay affects how long the CUB will wait after opening the refrigeration solenoid at the start of refrigeration before activating the compressor. Enter the desired delay in seconds.

```
Suction Setpoint
CutInPress : 55
CutOutPress: 45
MinimumPres: 1
```

NOTE

If you are using the Temperature compressor control strategy, the suction setpoints shown in this screen will be used as fallback suction setpoints, enabled only when the case Temperature Control Input fails.

Cut In Press and Cut Out Press

The Cut In setpoint determines the suction pressure that, when exceeded, will cause the compressor to turn ON. In this strategy, the compressor will remain ON until the pressure falls below the Cut Out setpoint, at which point the compressor will turn OFF.

Minimum Suction Pressure

The Minimum Suction Pressure setpoint serves two purposes. When the condensing unit is operating in Refrigeration mode using the Temperature strategy, the Minimum Suction Pressure is the suction pressure at which the compressor will be shut off regardless of the case circuit temperature. This setpoint is necessary as a safety feature since the CUB is controlling by temperature instead of by suction pressure.

If you enabled the Pump Down feature for this CUB, the Minimum Suction Pressure also acts as the termination setpoint for the pump down delay. The Pump Down period will end when the suction pressure falls below this setpoint.

NOTE

The following screens are only for CUB-II with Trad (Traditional) Strategy (Condenser SPs, Condenser Fan 1 Setpoints, and Condenser Fan 2 Setpoints).

8.2.4.6 Condenser SPs

```
Condenser SPs
Strategy: Trad
Num Fans: 2
```

Condenser Setpoints

The two fields on this screen show the strategy being used and the number of fans being controlled. The two following screens are for the strategy set to Traditional control. Traditional control uses Cut In/Cut Out setpoints for control based on discharge pressure. For TD setup, see **Section 8.2.4.1, Condenser Setpoints**.

Strategy

Set the type of condenser strategy that will be used to cycle fans ON and OFF.

Number of Fans

Set the number of fans to be turned ON and OFF by the chosen strategy type. The maximum number of fans that can be controlled is two.

8.2.4.7 Condenser Fan 1 Setpoints

```
Cond Fan #1
CutIn Press: 160
CutOut Pres: 140
MinOnTime: 1 M
```

The fields underneath the Condenser Fan #1 heading are where the Cut In/Cut Out setpoints for condenser fan #1 are programmed.

Cut In Pressure

When the discharge pressure rises above the Cut In setpoint, the fan will turn ON.

Cut Out Pressure

When the discharge pressure falls below the Cut Out setpoint, the fan will turn OFF.

Min ON Time

The minimum ON time is the smallest amount of time the condenser fan must remain ON after being activated.

If using two condenser fans, program fan # 1 with a lower Cut In setpoint than fan #2, so that the fans will come on in stages.

8.2.4.8 Condenser Fan 2 Setpoints

```
Cond Fan #2
CutIn Press: 170
CutOut Pres: 150
MinOnTime: 1 M
```

The fields underneath the Condenser Fan #2 heading are where the Cut In/Cut Out setpoints for condenser fan #2 are programmed.

Cut In Pressure

When the discharge pressure rises above the Cut In setpoint, the fan will turn ON.

Cut Out Pressure

When the discharge pressure falls below the Cut Out setpoint, the fan will turn OFF.

Min ON Time

The minimum ON time is the smallest amount of time the condenser fan must remain ON after being activated.

If using two condenser fans, program fan # 1 with a lower Cut In setpoint than fan #2, so that the fans will come on in stages.

8.2.5 Alarm Setpoints Screens

8.2.5.1 Case Hi and Lo Temp

```
Case HiTemp: 35
Case LoTemp: 15
AlarmDelay: 60 M
After Defr: 30 M
```

Case Temp High Setpoint

The Case Temp High Setpoint is the temperature at which a high case temperature alarm will be generated.

Case Temp Low Setpoint

The Case Temp Low Setpoint is the temperature at which a low case temperature alarm will be generated.

Alarm Delay

The Alarm Delay is the amount of time the case temperature must be above the high case temp setpoint or below the low case temp setpoint before an alarm will be generated. Enter the delay in number of minutes.

After Defrost

Because the case temperature can be considerably higher in a case that is exiting defrost, the Delay After Defrost allows you to prevent high case temp alarms from occurring for a fixed amount of time after the end of a defrost cycle. Enter the desired delay in minutes.

8.2.5.2 Phase Fail

```
PhaseFail Alarm
Phase Act: CLSD
Proof Act: CLSD
ProofDelay: 30 S
```

Phase Alarm/Notice

When a phase loss occurs, the CUB will generate either an alarm or a notice, depending on the value of this field.

Phase Fail Active State

The Phase Fail Active State tells the CUB what digital state from the phase loss checking device signifies a phase failure. Set this field to CLSD if the phase loss device closes its contacts on a phase failure, or OPEN if it opens contacts.

Proof Active State

The Proof Act field tells the CUB what digital state from the proof checking device means FAIL. If set to CLSD, the CUB will interpret a contact closure as FAIL. If set to OPEN, the CUB will interpret an open contact as FAIL.

Compressor Proof Delay

The Compressor Proof Delay is the amount of time a proof checking device must read FAIL before the CUB will consider the compressor to have failed. Enter the desired delay in seconds.

8.2.5.3 Shut Down On Proof

```
Comp ShutDownOn
ProofFail: YES
AutoResets: 1
ResetDelay: 4 M
```

Shut Down On Proof Fail

When the compressor fails, you have the option of either having the CUB control the compressor output as normal OR having the CUB lock the compressor OFF until the failure is reset. Set this field to YES if you want to lock the compressor OFF during failure. Set this field to NO if you want the CUB to continue attempting to control the compressor as normal.

Auto Resets

The AutoResets field determines how many times the CUB will attempt to automatically reset the compressor failure. After the retries have occurred, if the compressor is still failed, the CUB will consider the compressor failed until the compressor is reset manually.

Enter the desired number of resets per hour in this field.

Proof Reset Delay

The Proof Reset Delay is the amount of time the CUB will wait between retry attempts. Enter the number of minutes in this field.

8.2.5.4 Proof Failure

```
ProofFail Alarm
OilFailStpt: 9
OilFailDly: 120S
AutoRestarts: 0
```

Proof Fail

The ProofFail field determines whether the E2 or Einstein will generate an alarm or notice when a compressor proof failure occurs. Choose either Alarm or Notice in this field.

Oil Failure Setpoint

If you chose Pressure as the Oil Failure Type, the Oil Failure Setpoint is the pressure that indicates a low oil condition in the compressor. When the oil pressure falls below this setpoint, a compressor oil failure alarm will be generated.

Oil Failure Delay

The Oil Failure Delay is the amount of time an analog oil pressure transducer must be below the setpoint, or a digital pressure switch must be in the fail state before the CUB will shut off the compressor.

Auto Restarts

If you chose Pressure as the Oil Failure Type, the Auto Resets field sets the number of times the CUB will attempt to reset the oil failure by turning the compressor OFF and then ON. If the oil sensor still registers a failure after all retries have occurred, the CUB will consider the compressor failed and will not attempt another reset.

Enter a number of retries per hour from **0-2**.

8.2.5.5 Oil Restart Delay

```
OilRestDly: 0 M
OilFailRun: NO
OilFailType
: None
```

Oil Reset Delay

The Restart Delay is the amount of time the CUB will wait between retry attempts. Enter the desired restart delay in **minutes:seconds (M:SS)** format.

Oil Failure Run

This field determines whether the CUB will continue to attempt to control the compressor as normal even after an oil failure has occurred. If this field is set to **Yes**, the CUB will turn the compressor output ON and OFF as normal during an oil failure. If set to **No**, the CUB will turn the compressor OFF and will not reactivate it until the oil failure has been reset.

Oil Failure Type

Choose the type of input device used to check oil pressure on the condensing unit. Choose **Pressure** if using an analog pressure transducer, **Digital** if using a digital pressure switch, or **None** if you do not wish to generate oil failure alarms.

8.2.5.6 Digital Oil Failure

```
DigitalOilFail
Fail State: CLSD
AutoRestarts: 0
```

Digital Oil Fail State

If you chose **Digital** as the **Oil Failure Type**, the **Oil Fail State** is the state of the digital pressure switch that indicates a low oil condition. When the digital input transitions to this state, a compressor oil failure alarm will be generated.

Dig. Auto Restarts

If you chose **Digital** as the **Oil Failure Type**, the **AutoRestarts** field sets the number of times the CUB will attempt to reset the oil failure by turning the compressor OFF and then ON. If the oil switch still registers a failure after all retries have occurred, the CUB will consider the compressor failed and will not attempt another restart.

Enter a number of retries per hour from **0-2**.

8.2.5.7 High Discharge Alarm

```
HiDischAlrm: 325
Disch Trip: 350
Reset Diff: 100
Reset Delay: 0 M
```

High Discharge Pressure Alarm

Enter the discharge pressure level that, when exceeded, will cause a discharge pressure alarm to occur.

Discharge Trip

Enter the discharge pressure level that, when exceeded, will cause a system shutdown. The Discharge Trip setpoint should be higher than the Discharge Pressure Alarm setpoint.

Reset Diff

A condensing unit that has been shut down due to discharge trip can be automatically reset. When the discharge pressure falls below the discharge trip setpoint minus the reset differential (*Disch Trip - Reset Diff*) the CUB will attempt to reset the discharge trip failure if the reset delay timer has expired.

Reset Delay

The Reset Delay is the amount of time the CUB will wait after a Discharge Trip before it will attempt a reset (if the Reset Differential has been met). Enter the desired **Delay** in **minutes (M)** format.

8.2.5.8 High Discharge Auto Resets

```
Auto Resets: 0
Comp Bypass
Max Time: 60 M
```

Auto Resets

The Auto Resets field sets the number of attempts the CUB will make to automatically reset the system within an hour after a discharge trip shutdown has occurred. After all attempts have been made and the discharge trip is still occurring, the CUB will lock the compressor OFF until the system is manually reset.

Enter a number of retries per hour from **0-2**.

Comp Bypass Max Time

The Compressor Bypass Max Time sets the maximum amount of time a refrigeration ON bypass will last when initiated from the E2 or Einstein. If refrigeration is bypassed ON past this time, the bypass will end and the CUB will resume regular control.

8.2.5.9 Door Switch

```
DoorSwitch
Open State: CLSD
Fail Time: 45 M
AlarmTime: 60 M
```

Door Switch Open State

The Door Switch Open State specifies whether an open door causes the door switch to be **OPEN** or **CLOSED**. Choose the door switch state that corresponds to “**door open**” in this field.

Door Switch Fail-Safe

After the door has been opened, the E2 or Einstein records how long the door remains open. If it remains open longer than the Door Switch Fail-Safe Time, the E2 or Einstein will assume the door is stuck open and will restart refrigeration to prevent food loss. Enter the desired fail-safe time in minutes.

Door Switch Alarm Time

After the door has been opened, the CUB records how long the door remains open. If it remains open longer than the Alarm Time, the CUB will generate an alarm. Enter the desired alarm time in minutes.

8.2.5.10 Wash Switch

```
Wash Switch
WashActive: CLSD
Fail Time: 120 M
```

Wash Switch Active State

The Wash Switch Active State specifies whether an **OPEN** or a **CLOSED** contact on the clean switch indicates “**enter wash mode**.” Choose either **OPEN** or **CLSD** in this field.

Wash Fail-Safe Time

The Wash Fail-Safe time allows you to suspend Wash mode and resume refrigeration if Wash mode lasts longer than a fixed amount of time. Enter the desired **Wash Fail-Safe** time in **minutes (MM)** format.

8.2.6 Defrost Setup Screens

The series of screens under the “Defrost” heading are where the parameters that control defrost must be specified.

8.2.6.1 Defrost Type

```
Defrst: Electric
PumpDwn: Enable
Term Type
: Term Temp
```

Defrost Type

Choose the manner in which the case circuit will be defrosted in the **Defrst** field. There are two options:

- **Off Cycle** - Refrigeration will be disabled, and no heat will be directly applied to the evaporator.
- **Electric** - Refrigeration will be disabled, and electric heat will be applied to the evaporator.

Pump Down

This field is shown only when **Electric defrost** is selected as the **Defrost Type**. Enabling Pump Down causes the CUB to delay transition from Refrigeration to Defrost to allow refrigerant to be pumped out of the evaporator. Pump Down uses the refrigeration solenoid.

To enable the Pump Down delay, set this field to **ENABLE**. To disable the Pump Down Delay, set this field to **DISABLE**.

Termination Type

The Termination Type determines which sensor’s value will be used to determine when a defrost cycle must be terminated. There are six options:

- **Digital** - Digital temperature sensor (Klixon).
- **Term Temp** - Analog temperature sensor. Defrost will terminate when the temperature is above the termination temp setpoint.
- **Time** - Defrost will terminate when defrost time expires (this is the same as no termination).
- **Min Case Temp** - Instead of using a dedicated “Term Temp” sensor, the CUB will use the lowest value among all case temperature sensors as the defrost termination temperature value.
- **Suction Pressure** - The suction pressure transducer. Defrost will terminate when suction pressure rises above the termination pressure setpoint.
- **Case Temp 1-6** - Instead of using a dedicated “Term Temp” sensor, the CUB will use one of the six case temperature sensors as the termination sensor during defrost.

8.2.6.2 Fan Control

```
EvapFanDefr: OFF
EvapFanIdle: ON
EvapFan On Delay
AfterDefr: 15 S
```

Evap Fans During Defrost

This field determines the state of the case circuit evaporator fans when defrost is active for the circuit. Set this field to **ON** to turn the case fans ON during defrost, or **OFF** to turn the case fans OFF.

Evap Fans During Idle

This field determines the state of the case circuit evaporator fans when the case temperature setpoint is satisfied and refrigeration is not active in the case. Set this field to **ON** to leave the case fans ON during idle, or **OFF** to turn the case fans OFF.

Evap Fan ON Delay After Defrost

This parameter delays the amount of time the CUB will wait after a defrost has ended before turning on the evaporator fans. This delay is designed to keep the fans from blowing moisture off the coil and onto the case doors or walls. Enter the desired delay in seconds.

8.2.6.3 Defrost Times

```
Duration: 45 M
MinDefDur: 2 M
Drip Time: 2 M
NumSchedules: 4
```

Defrost Duration

The Defrost Duration is the maximum amount of time a defrost cycle will last. Unless it is prematurely terminated by temperature or suction pressure, a defrost cycle will end when it has been in defrost for an amount of time equal to this field (not including any Pump Down or drip delays).

Enter the desired Defrost Duration in minutes.

Minimum Defrost Duration

The Minimum Defrost Duration sets the minimum amount of time a defrost cycle will last. A defrost cycle will always last at least as long as this time, and will ignore all calls for defrost to terminate until the Minimum Defrost Time has elapsed.

Enter the desired Defrost Duration in minutes.

Drip Time

The Drip Time is a delay between the end of defrost and the resuming of refrigeration to allow excess moisture to drain from the evaporator coil.

During the drip time, both the refrigeration and defrost outputs will be OFF. When the drip time has elapsed, refrigeration will resume in the case circuit.

Enter the desired drip time, in minutes, in this field.

Number of Defrost Schedules and Defrost Time

The Number of Defrost Schedules sets the number of daily defrosts for this circuit. This field is automatically filled in for you when you select a case type in the **Case Type** field.

Enter a number from **1 through 6** in this field.

8.2.6.4 Defrost Schedule Screens 1 and 2

Defrost Schedule			
1	0:00	2	6:00
3	12:00	4	18:00
5	NOVAL	6	NOVAL
Defrost Schedule			
7	NOVAL	8	NOVAL
9	NOVAL	10	NOVAL
11	NOVAL	12	NOVAL

The twelve numbered fields in these two screens are where the defrost start times for the CUB are entered.

If you chose a case type in the **Case Type** field, the defrost times corresponding to your case type will be entered for you. Otherwise, enter the defrost start times you wish to use for the CUB in the twelve numbered fields. Times must be entered in 24-hour format.

8.2.7 Input Setup Screens

The series of screens under the **"Input"** Main Menu option will choose the name, type, and offset for each of the 16 inputs on the CUB board. Use the **DOWN ARROW** keys to scroll through all configuration screens from **1 to 16**.

8.2.7.1 Input Setup

Input Setup 1 Name: CaseTemp1 Type: TEMP Offset: 0

Name

The Name field is where you must specify the function of the input device attached to the point. Use the **Point and Dash keys** to scroll through the possible values for this field (see **Table 8-2**).

If this input will not be used for this CUB, choose the **NOT USED** option in the Name field.

Table 8-2 - MultiFlex CUB Input Names

Name	Description
Suct Xdcr	Suction pressure transducer
Disch Xdcr	Discharge pressure transducer
Oil Xdcr	Analog oil pressure transducer
Case 1 Temp-Case 6 Temp	Case temperature sensors # 1 through #6
DrLeg Temp	Drop Leg temperature sensor
Term Temp	Analog termination temperature sensor (NOT digital — use Defrost Term Sensor for digital sensors)
Term Dig	Digital defrost termination sensor (NOT analog — Use Term Temp for analog termination sensors)
Alarm Reset	Alarm reset button or switch
Door Switch	Door switch
Clean Switch	Clean switch
Disch Temp	Discharge temperature
SensCtrl 1-2	Input for Sensor Control modules # 1 through #2
Comp Proof	Compressor proof
Phase Loss	Phase loss checking device
KW	Analog KW transducer input
Suct Temp	Suction Temperature probe
Oil Dig	Digital oil pressure switch
NOT USED	Input value is unused

NOTE

You may choose to have multiple inputs assigned to the same Sensor Control module. These inputs will be combined by the CUB-II's sensor control application using the strategy chosen in Sensor Control.

Type

The Type field tells the CUB what kind of sensor is providing the input value. This value of this field must correspond to the type of input suggested by the Name field. For example, if the Name of an input is Suct Temp, CaseTemp1, or one of the other analog temperature sensor types, the Type field must be set to TEMP in order for the input signal from the sensor to be read like a temperature sensor.

Note that when you choose a value for the Name field, the CUB does not automatically enter an appropriate default value in the Type field. You must manually enter the type for all sensor inputs.

Table 8-3 lists the input types available for sensor control inputs.

Table 8-3 - CUB Sensor Control Input Types

Input Type	Description
Temperature	Analog temperature sensor
12v-100PSI	12v transducer, 0-100PSI
12v-200PSI	12v transducer, 0-200PSI
12v-500PSI	12v transducer, 0-500PSI
5v-100PSI	5v transducer, 0-100PSI
5v-200PSI	5v transducer, 0-200PSI
5v-500PSI	5v transducer, 0-500PSI
Humidity	Relative Humidity Sensor
Power-KW	Kilowatt transducer, 1-5VDC analog output signal
Ref Leak	Refrigerant Leak Detector
Dewpoint	Dewpoint Probe
LM235-TEMP	LM235 Temp Probe
Ref Level	Refrigerant Level Transducer
Liq Level	Liquid Level Transducer
Light Level	Light Level Sensor

Table 8-3 - CUB Sensor Control Input Types

Input Type	Description
Pulse-Cnt	Kilowatt transducer, pulse KW output signal
Dig-ON/OFF	Digital ON/OFF signal
Linear-V	0-5 V linear sensor

8.2.8 Outputs Screens

Out #1	Comp
Out #2	Defrost
Out #3	CondFan1
Out #4	Remote
Out #5	Remote
Out #6	Remote
Out #7	Remote
Out #8	Alarm

The two screens under the heading "Output" are where you assign each of the eight relay outputs to a controlled device in the condensing unit system.

Table 8-4 - CUB Sensor Control Output Types

Sensor Control Input Type	Description
Comp	The compressor
CondFan1	Condenser fan #1
CondFan2	Condenser fan #2
CondFan3	Condenser fan #3
CondFan4	Condenser fan #4
Defrost	The defrost output
Refr Sol	Refrigeration solenoid
Evap Fan	Case evaporator fan
Alarm	The alarm output (turns ON when alarm condition exists on CUB)
SensCtrl1	Output controlled by sensor control loop #1
SensCtrl2	Output controlled by sensor control loop #2
Remote	Unused by CUB, but may be controlled by E2 or Einstein remotely
NDF	Not defined

8.2.9 Auxiliary Inputs Screens

8.2.9.1 Pulse KW Setup

Pulse KW Setup KWH per Pulse: 20
--

KW Per Pulse

If you are using a pulse accumulation type KW transducer, you must enter the number of KW per pulse for this transducer in this field.

8.2.9.2 Analog KW Setup

Analog KW Setup
Volts KW
Min: 0 0
Max: 5 5000

KW Analog

If you are using an analog KW transducer, you must enter the voltage range of the input and the range of KW values the voltage corresponds to. This information is different for each KW Transducer and depends on the line voltage and current transducer (CT) rating. Refer to your KW transducer's installation instructions.

Under the Volts column, enter the minimum and maximum sensor output voltages. Under the KW column, enter the minimum and maximum KW represented by the min/max voltage range.

8.2.9.3 Linear 1 and 2 Setup

Linear 1 Setup
Volts Output
Min: 0 0
Max: 5 100

Linear 2 Setup
Volts Output
Min: 0 0
Max: 5 1000

Linear 1 and 2

If you wish to use one or both of the Linear 1 and Linear 2 sensor types used by the sensor control applications, you must specify the voltage range of the sensor output and the range of values those voltages represent.

Under the Volts column, enter the minimum and maximum sensor output voltages. Under the Output column, enter the minimum and maximum engineering unit values represented by the min/max voltage range.

8.2.10 Sensor Control Screens

The screens under the Sensors menu option are for setting up sensor control applications. Each of the two sensor control applications have four screens full of fields that must be configured. To program Sensor Control application #2, you must scroll down through the first four Sensor Control #1 screens.

8.2.10.1 Sensor Screen 1 (Name, Type)

SnsrCntrl 1 Name
SC 1
Type: OAT

Sensor Name

By default, the name of the two sensor control applications are **SC 1** and **SC 2** respectively. To choose a different name, enter it in this field.

Type

The Type in sensor control tells the CUB what special function, if any, the sensor control application is performing. This field is different from the Type field in the **Input Setup** screen (see **Section 8.2.7.1, Input Setup**), which specifies the type of sensor that is providing the input.

Table 8-5 describes the choices that may be selected for the **Sensor Control Type** field, along with their meanings.

Table 8-5 - Sensor Control Types

Input Type	Description
Generic	The sensor control application exists simply to control an output and to generate hi/lo alarms.
OAT	Choose this option if the input is reading outdoor air temperature. This will allow the CUB to share the OAT value with E2 or Einstein for use in other applications.
MotorRM T	Choose this option if the input is an air temperature sensor in the CUB's motor room. This passes the sensor value to E2 or Einstein's Global Data for sharing with other CUBs in the same zone.
Linear 1	The sensor connected to this input uses the linear properties for volts and engineering units specified in Screen 4, Auxiliary Inputs, for "Linear 1."
Linear 2	The sensor connected to this input uses the linear properties for volts and engineering units specified in Screen 4, Auxiliary Inputs, for "Linear 2."
Ref. Leak	The sensor is a refrigerant leak detector.
Light Level	The sensor is a light level sensor.
Humidity	Relative Humidity Sensor.

8.2.10.2 Sensor Screen 2 (Cut In/Out, Min ON/OFF)

```
S1 CutIn: 10
S1 CutOut: 5
S1 MinOn: 1 M
S1 MinOff: 1 M
```

S1 Cut In and S2 Cut In

The S1 Cut In and S2 Cut In setpoints are the input values at which the sensor control outputs will transition from OFF to ON. Refer to **Section 6.4.1, How Cut In/Cut Out Control Works**, for further explanation.

S1 Cut Out and S2 Cut Out

The S1 Cut Out and S2 Cut Out setpoints are the input values at which the sensor control outputs will transition from ON to OFF. Refer to **Section 6.4.1, How Cut In/Cut Out Control Works**, for further explanation.

S1 MinOn and S2 MinOn

The S1 Minimum ON Time and S2 Minimum ON Time parameters set the amount of time a sensor control output must remain ON after activating before being allowed to turn OFF. Enter the desired time in minutes.

S1 MinOFF and S2 MinOFF

The S1 Minimum OFF Time and S2 Minimum OFF Time parameters set the amount of time a sensor control output must remain OFF after deactivating before being allowed to turn ON. Enter the desired time in minutes.

8.2.10.3 Sensor Screen 3 (Hi/Lo Alarm)

```
S1 HiAlarm: 20
S1 LoAlarm: 1
AlarmDelay: 0 M
```

S1 Hi Alarm and S2 Hi Alarm

The S1 HiAlarm and S2 HiAlarm fields set the high alarm setpoint for the Sensor Control applications. Whenever a sensor control input rises above the Alarm Hi setpoint, an alarm will be generated.

S1 Lo Alarm and S2 Lo Alarm

The S1 LoAlarm and S2 LoAlarm fields set the low alarm setpoint for the Sensor Control application. Whenever the sensor control input falls below the low alarm setpoint, an alarm will be generated in the parent E2 or Einstein.

Alarm Delay

The Alarm Delay for Sensor Control 1 and 2 (S1 and S2) set the amount of time the sensor control input must remain above the high alarm setpoint or below the low alarm setpoint before an alarm will be generated. Enter the desired alarm delay in minutes.

8.2.10.4 Sensor Control Screen 4 (Alarm Priority, Comb Method)

```
AlmPriority: 1
CombMethd: First
Eng Units: NDF
```

Alarm Priority

The Alarm Priority field determines the priority level of the high and low level alarms generated by this sensor control application. The priority level is used by the parent E2 or Einstein to determine how the alarm will be reported and handled.

Comb Method

The Comb Method only applies if you assigned more than one input to this Sensor Control application. When multiple inputs are being used, they will be combined into a single input value using the method chosen in this field.

There are five strategies to choose from:

- **AVG** - The average value of all case temperature inputs.
- **MIN** - The lowest sensor value of all the case temperature inputs.
- **MAX** - The highest sensor value of all the case temperature inputs.
- **MIX** - A mixture of two inputs, the ratio of which is determined by the Mix % field. Mix will use the Mix % for the Case Temp Combination under the Setpoints screens (refer to *Mix Percentage* in **Section 8.2.4.4, Comb Method**).
- **FIRST** - The lowest-numbered input that is not shorted, open, or otherwise invalid, will be used as the case temperature input. If you are not using more than one input, set the CombMethd field to First.

Eng Units

Select the engineering units that should be applied to the input type you are using for this sensor control application.

Table 8-6 - Engineering Units Defined

Engineering Units	
DF	Degrees Fahrenheit
DC	Degrees Celsius
PSI	Pounds Per Square Inch
KPA	Kilopascals
RH	Relative Humidity
V	Volts
FTC	Foot Candles
LUX	Light Level
PPM	Parts Per Million
NDF	Not Defined

Appendix A: TD Quick Start

Set Up Motor Room Temperature and Plenum Temperature Inputs

NOTE This section contains an overview for setting up TD Control for CUB-II or CUB-TD. In this section of the manual, the term "CUB" will be used to mean "CUB-II and, if appropriate, CUB-TD."

CUB can have up to four motor room temperature zones, which are pre-associated with Global Data spare analog inputs 1-4. The default CUB zone is 1, which associates Motor Room Temp 1 to all CUBs in Zone 1. For CUBs, the spare analog inputs must be set up for local only/degrees fahrenheit, and assigned to an input board and point.

Note that CUB has the option of getting motor room temp from an input on the CUB board itself. If this option is used, the TD board and point assignment will be overridden. See **Section 6.4.2, Motor Room Temperature Control** for more information.

Plenum Temperature

Because Global Data Spare Analog Inputs 1-4 are preassigned to Motor Room Temps 1-4, begin setup of plenum temps with Spare Analog Input 5. If Spare Analog Input 5 is being used, begin at the next unoccupied analog input. For example, if four plenum temps are used, they will come from Spare Analog Inputs 5-8.

NOTE You cannot use Global Data’s SPARE ANLG 01 through 04 inputs for any purpose other than motor room temps; they are predefined. If you need to use some of Global Data’s “Spare Analog” slots to share values, (plenum temp) use SPARE ANLG 05 through 08.

Global Data Setup Example

One 16AI board is needed for this setup example, which will be Board 1. The 16AI has Motor Room Temp 1 on Input 1, and the first plenum temp on Input 9.

To begin programming the CUB-TD, navigate to the Global Data screen to define Global Data points. Press **F8** followed by **Y** and **8** to enter **Global Data Setup**.

If using an E2 controller, press **Menu**, **8** (System Configuration), **8** (Global Data), **F5** (Setup) to enter **Global Data Setup**.

1. Under **S1: Inputs**, arrow down to Spare Anlg Mode and set to Local Only. Press **F8** for **Look Up** menu (**F4** for **Look Up** if using an E2).
2. Arrow down to **Spare Anlg EU** and set to **DF** (Degrees Fahrenheit). Press **F7** for **Look Up** menu (**F4** for **Look Up** if using an E2).

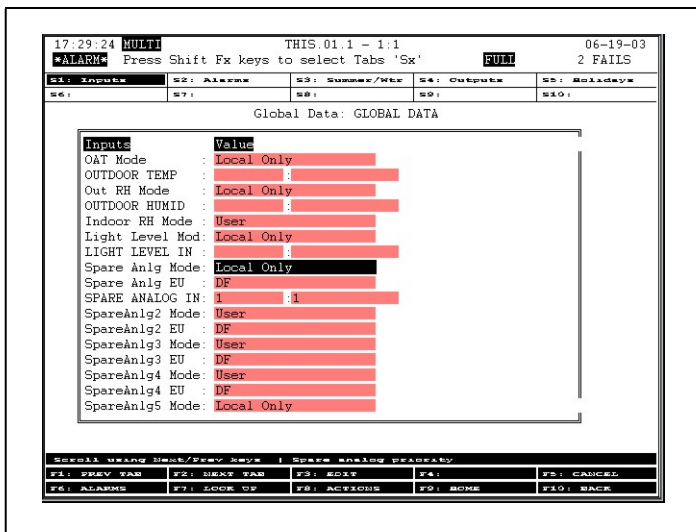

Figure A-1 - Global Data Setup Local Only Mode

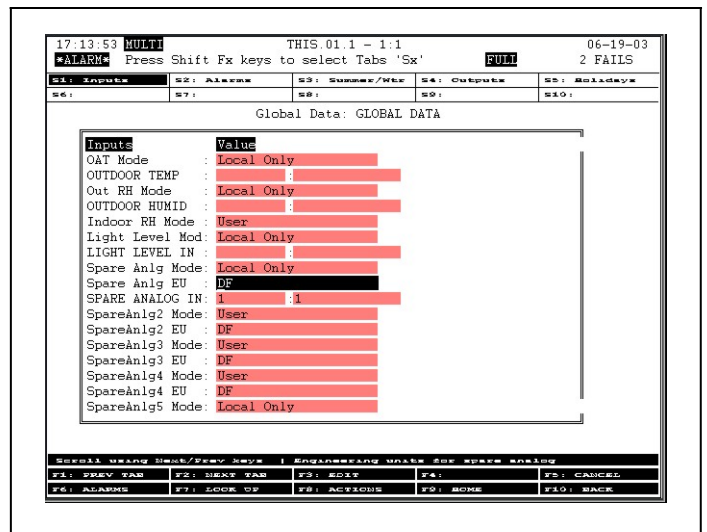

Figure A-2 - Global Data Setup Degrees Fahrenheit

- To set the motor room temperature, arrow down to **SPARE ANALOG IN** and arrow right to set **Board** to **1** and **Point** to **1**.

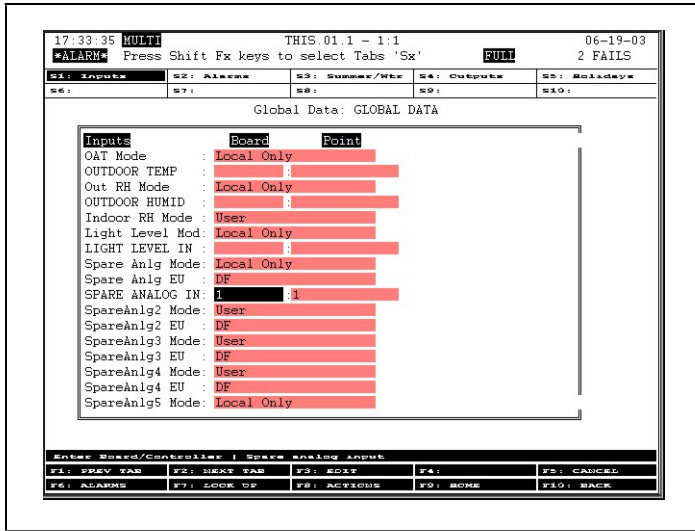

Figure A-3 - Global Data Setup Board and Point

- Arrow down to **SpareAnlg5 EU** (Engineering Units) and set to **DF** (Degrees Fahrenheit). Press **F7** for **Look Up** menu (**F4** for **Look Up** if using an E2).

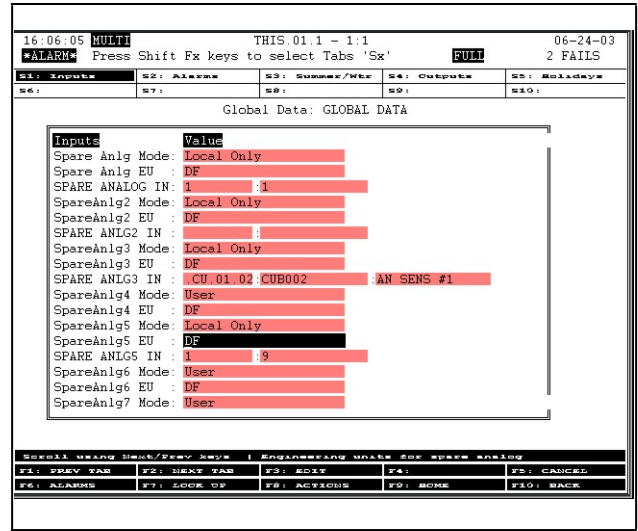

Figure A-5 - Global Data Setup Spare Analog 5 EU

- Arrow down to **SpareAnlg5 Mode** and set to **Local Only**. Press **F7** for **Look Up** menu (**F4** for **Look Up** if using an E2).

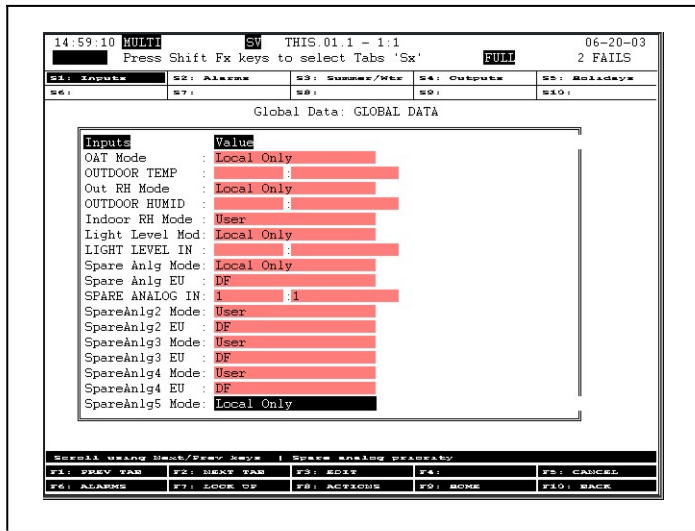

Figure A-4 - Global Data Setup Spare Analog 5 Mode

- Arrow down to **SPARE ANL5 IN** and arrow right to set **Board** to **1**, and **Point** to **9**.



Figure A-6 - Spare Analog 5 Input Board/Point

Configuring Setpoints in E2 or Einstein for CUB-TD

The CUB application in E2 and Einstein looks the same for both CUB and CUB-TD versions of the MultiFlex CUB. However, since the CUB-TD's functionality is limited to condenser control, not all parameters visible in the E2 and Einstein setup screens will apply to the CUB-TD. If you are setting up a CUB-TD, this section will walk you through setting up only the inputs, outputs, and setpoints that pertain to the CUB-TD.

Inputs

These input points (motor room temp and plenum temp) come from Global Data because they are shared among multiple CUB TDs. Refer to **Set Up Motor Room Temperature and Plenum Temperature Inputs on page 54** for more information about Global Data setup for motor room and plenum temperature.

1. From the **MultiFlex CUB Status** screen, press **F8** and **B** to set up **Inputs** (press **F5** from the **MultiFlex CUB Status** screen if using an E2).
2. Press **F2** to move to the **Inputs** tab, and set **Controller, Application, and Output** for plenum temp.

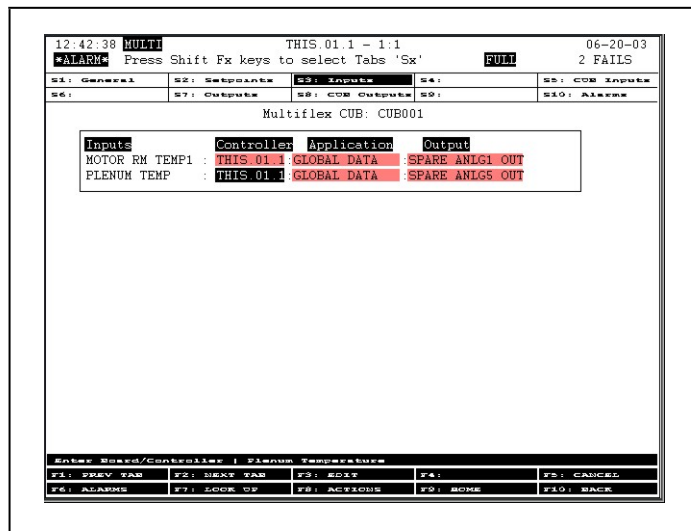

Figure A-7 - CUB Setup Plenum Temp

3. Set **Controller** to the name of the Einstein that is currently being set up (the controller you are setting the CUB TDs to). Next, set **Application** to **GLOBAL DATA** and **Output** to **SPARE ANLG5 OUT** (the Spare Analog Out the plenum temp for this CUB is assigned to).
4. Press **F10** to exit screen and save changes, or **F9** to return to the **Home** screen.

If using an E2, press to exit and save or to return to the Home screen.

CUB Inputs

From the **MultiFlex CUB Status** screen, press **F8** and **B** to set up **CUB Inputs** (press **F5** from the **MultiFlex CUB Status** screen if using an E2).

1. Press **F2** to move to the **CUB Inputs** tab, and set **Input 1** to **Dropleg Temp**, and **Type 1** to **Temperature**. Press **F7** for **Look Up** menu (**F4** for **Look Up** if using an E2).
2. Set **Offset** to **0** (zero). The rest of the Inputs on this screen should be set to **None**, the **Input Types** to **None**, and **Offsets** to **0** (zero).
3. Press **F10** to exit screen and save changes, or **F9** to return to the **Home** screen.

If using an E2, press to exit and save or to return to the Home screen.

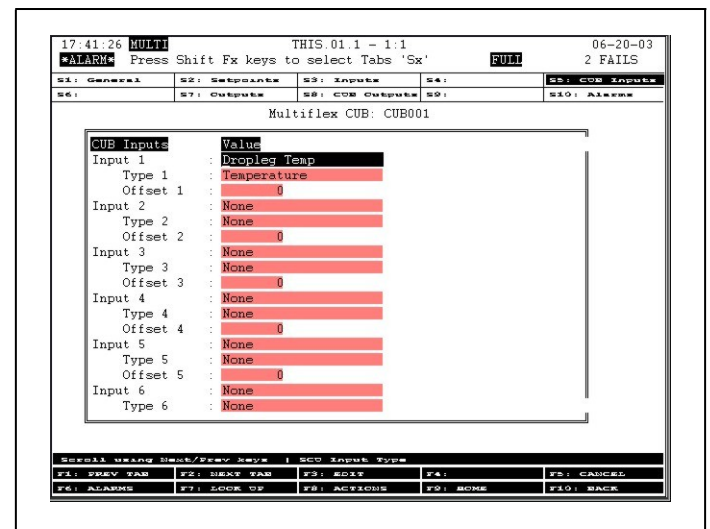



Figure A-8 - CUB Inputs Setup DropLeg Temperature

CUB Outputs

From the MultiFlex CUB Status screen, press **F8** and **B** to set up **Outputs** (press **F5** from the **MultiFlex CUB Status** screen if using an E2).

1. Press **F2** to move to the **CUB Outputs** tab, and set **Outputs 1-4 to Condenser Fans 1-4**, respectively (depending on the number of fans being controlled). Press **F7** for **Look Up** menu (**F4** if using an E2).
2. Press **F10** to exit screen and save changes, or **F9** to return to the **Home** screen.

If using an E2, press  to exit and save or  to return to the Home screen.

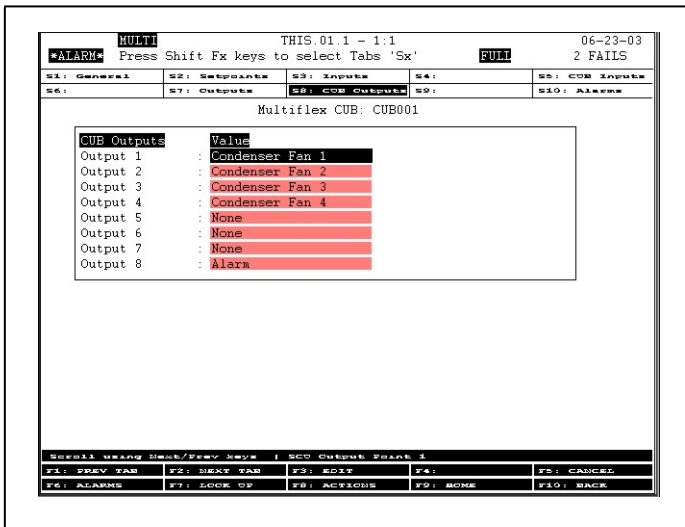

Figure A-9 - CUB Outputs

General

From the MultiFlex CUB Status screen, press **F8** and **B** to access **General** tab options (press **F5** from the **MultiFlex CUB Status** screen if using an E2).

1. Arrow down to the **Num Cond Fans** field and set the number of fans to be controlled. This number should match the number of condenser fans set in **Outputs** under the **CUB Outputs** tab (**CUB Outputs on page 57**).
2. Arrow down to **Network Alm** field and set to **ENABLE** to enable network alarming. If network alarming is enabled, the CUB output configured as **Alarm** type will turn **ON** when the network loses communication with the controller.

For example, **Network Alm** is set to **ENABLE** (Figure A-10), and Output 8 is set as the Alarm output (Figure A-9).

3. Application names can be user defined. To change the name of the TD application from the default, arrow up to the **Name** field and enter the desired name.

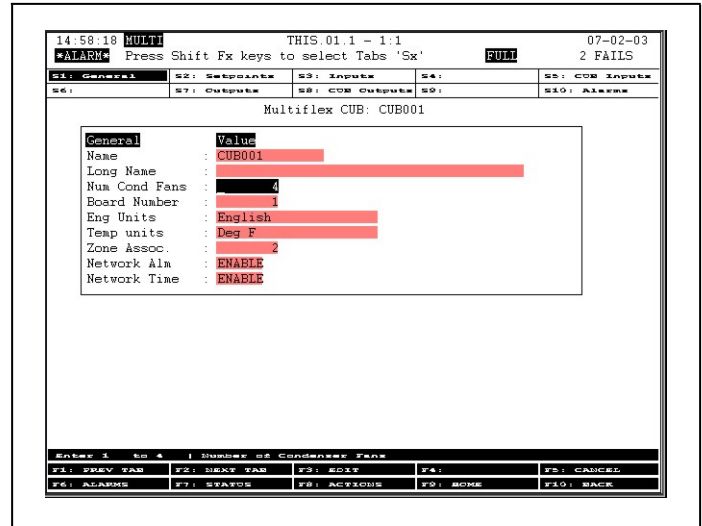

Figure A-10 - General Tab in CUB TD Setup

Setpoints

Press **F2** to move to the Setpoints tab.

1. To set the **TD Setpoint**, arrow down to the **TD setpoint** field and enter the desired number (the default is **15.0**). TD Setpoint is the setpoint that is maintained by cycling fans ON and OFF.
2. To set **TD deadband**, arrow down to the **TD deadband** field and enter the desired number (the default is **1.0**). TD deadband forms a range of TD values equally above and below the setpoint within which the control TD value is considered to be within limits.
3. To set the **DropLeg Maximum**, arrow down to the **Drop Leg Max** field and enter the desired number (the default is **100.0**). If the DropLeg Temp rises above this setpoint, the fans will stage ON using Condenser Fan On Delay.
4. To set the **DropLeg Minimum**, arrow down to the **Drop Leg Min** field and enter the desired number (the default is **70.0**). If the DropLeg Temp falls below this setpoint, the fans will stage OFF using Condenser Fan Off Delay.
5. To set the **DropLeg Offset**, arrow down to the **Drop Leg Offset** field and enter the desired number (the default is **0**). DropLeg Offset is a way of adding or subtracting an offset to the drop leg temperature sensor reading (if needed) in order to tune the individual condensing unit.

- To set the **Condenser Fan On Delay**, arrow down to the **Cond Fan On Dly** field and enter the desired number (the default is **30**). This setpoint defines the amount of time that must elapse between activation of fan stages. Enter the desired delay in **hours:minutes:seconds (H:MM:SS)**.
- To set the **Condenser Fan Off Delay**, arrow down to the **Cond Fan Of Dly** field and enter the desired number (the default is **30**). This setpoint defines the amount of time that must elapse between deactivation of fan stages. Enter the desired delay in **hours:minutes:seconds (H:MM:SS)**.

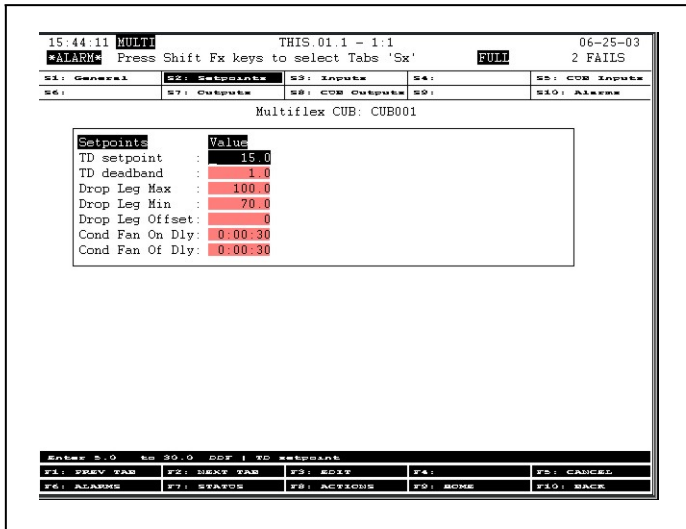

Figure A-11 - Setpoints Tab in CUB TD Setup

Alarms

Press **F2** to move to the **Alarms** tab.

- To set the high alarm setpoint for drop leg temperature, arrow down to the **Drop Leg High** field and enter the desired number (the default is **NONE**).
- To set the alarm delay setpoint for drop leg temperature, arrow down to **Drop Leg Dly** field and enter the desired time in **hours:minutes (HHH:MM)**.
- To set the high alarm setpoint for temperature differential, arrow down to the **TD High** field and enter the desired number (the default is **NONE**).
- To set the alarm delay setpoint for drop leg temperature differential, arrow down to **TD Dly** field and enter the desired time in **hours:minutes (HHH:MM)**.

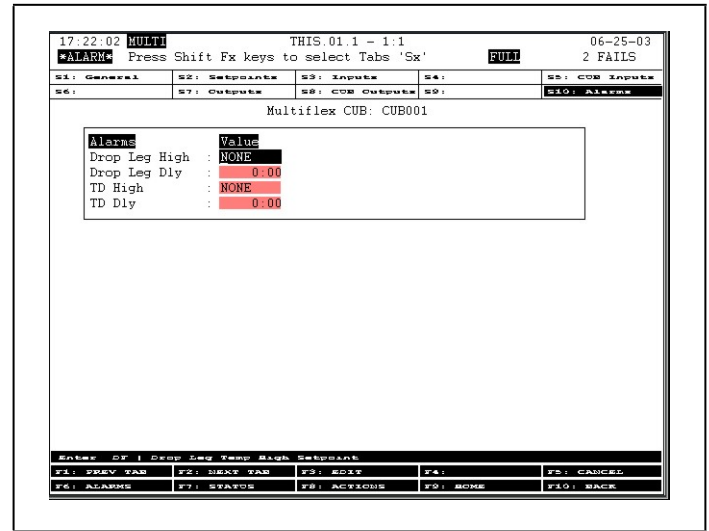



Figure A-12 - Alarms Tab in CUB TD Setup

Press **F10** to exit screen and save changes, or **F9** to return to the **Home** screen.

If using an E2, press  to exit and save or  to return to the **Home** screen.

Appendix B: Case Type Defaults

The table below lists the 64 default case types that may be used in CUB applications along with the recommended defaults for each case type.

When one of these 64 case types is selected, the CUB automatically enters the following information from the table into the Circuit application:

- The setpoint, and
- The number of defrosts per day and the defrost time length from the **Elec** column under **Defrost Type**.

For example, if you select #14 "RIFF" (reach-in frozen food), the CUB sets the circuit's setpoint at -10, the number of defrosts at 1, and the defrost time at 60 minutes.

The other columns in this table, such as the **High Alarm, Low Alarm, Delay, Hot Gas, Rev. Air,** and **Timed** columns, are suggested values that are not automatically entered into the CUB application.

High Alarm, Low Alarm, and Delay

The **High Alarm, Low Alarm, and Delay** columns are the suggested high and low case temperature alarm setpoints and the report delay. To set up these alarm setpoints and delays, go into the CUB application in E2 or Einstein.

Defrost Type

When a **Case Type** is defined, the CUB assumes by default that the defrost type is **Electric**. The CUB also supports **Off Cycle** defrost type. If using Off Cycle defrost, you will have to enter new values for the number of defrosts (**Num Defr Scheds**) and the defrost times (**Defr Time**) in the **CUB Defrost Setup** screen. **Hot Gas, and Rev. Air** defrost types are not supported by the CUB.

The suggested defaults are listed under the **Timed** column in **Table 8-7** below. The number to the left of the slash indicates the suggested number of defrost times per day (**Num Defr Scheds**), and the number to the right of the slash indicates the recommended defrost time length (**Defrost Dur.**).

Table 8-7 - Case Type Default Settings

Type	Abbr.	Description	Set Point	High Alarm	Low Alarm	Delay	Defrost Type			
							Hot Gas	Elec. (DEF)	Rev. Air	Timed
0	****	Undefined								
1	SDIC	Single deck ice cream	-25	-5°	-30°	01:00	2/18	1/45	1/60	1/60
2	MDIC	Multi-deck ice cream	-25	-5°	-30°	01:00	3/22	3/45	2/60	2/60
3	SDFJ	Single deck freezer juice	-18	0°	-30°	01:00	2/18	1/45	1/60	1/60
4	MDFJ	Multi-deck freezer juice	-10	5°	-25°	01:00	3/22	3/45	2/60	2/60
5	RIIC	Reach-in ice cream	-15	-5°	-25°	01:00	2/22	1/45	1/60	1/60
6	ICBX	Ice cream freezer box	-20	-5°	-30°	01:00	3/20	2/45	2/60	2/60
7	SDFF	Single deck freezer food	-15	5°	-25°	01:00	2/18	1/60	1/60	1/60
8	RIFJ	Reach-in freezer juice	-15	-5°	-20°	00:15	2/22	1/45	1/60	1/60
9	FRBX	Frozen food box	-12	-5°	-20°	00:15	3/18	3/45	2/60	2/60
10	FFBX	Frozen fish box	-12	-5°	-20°	00:15	3/18	3/45	2/60	2/60
11	FJBX	Frozen juice box	-12	-5°	-25°	01:00	3/18	3/45	2/60	2/60
12	MDFF	Multi-deck freezer food	-10	0°	-20°	01:00	2/22	1/45	2/60	2/60

Table 8-7 - Case Type Default Settings

Type	Abbr.	Description	Set Point	High Alarm	Low Alarm	Delay	Defrost Type			
							Hot Gas	Elec. (DEF)	Rev. Air	Timed
13	FZBK	Multi-deck freezer bakery	-10	0°	-20°	01:00	2/22	1/45	2/60	2/60
14	RIFF	Reach-in freezer food	-10	5°	-15°	01:00	1/20	1/60	1/60	1/60
15	SDMT	Single deck meat	22	32°	12°	01:00	3/18	3/45	3/60	3/60
16	SDPF	Single deck prepared	22	32°	12°	01:00	3/18	3/45	3/60	3/60
17	PZZA	Single deck pizza	22	32°	12°	01:00	3/18	3/45	3/60	3/60
18	KOSH	Single deck kosher	22	32°	12°	01:00	3/18	3/45	3/60	3/60
19	SDFH	Single deck fish	22	32°	12°	01:00	3/18	3/45	3/60	3/60
20	MDMT	Multi-deck meat	23	34°	18°	01:00	4/18	4/45	4/60	4/60
21	MDPO	Multi-deck poultry	23	34°	18°	01:00	4/18	4/45	4/60	4/60
22	MDFH	Multi-deck fish	23	34°	18°	01:00	4/18	4/45	4/60	4/60
23	RIMC	Reach-in meat	25	35°	15°	01:00	2/18	2/45	2/60	2/60
24	SVMT	Service meat	22	35°	15°	01:00	2/18	2/45	2/60	2/60
25	SVFH	Service fish	22	35°	15°	01:00	2/18	2/45	2/60	2/60
26	MTBX	Meat cooler	30	42°	22°	01:00	3/18	3/45	2/60	2/60
27	HDBX	Meat holding box	30	44°	22°	01:00	3/18	3/45	2/60	2/60
28	DYCS	Multi-deck dairy	35	44°	24°	01:00	4/20	4/45	2/60	4/60
29	RFDY	Rear load dairy	28	38°	18°	01:00	4/20	4/45	2/60	4/45
30	RIDY	Reach-in dairy	30	40°	20°	01:00	4/20	4/45	2/60	2/60
31	DYBX	Dairy cooler	34	44°	24°	01:00	2/22	2/45	2/60	2/60
32	BKBX	Bakery Cooler	36	46°	26°	01:00	2/22	2/45	2/60	2/60
33	PRBX	Produce cooler box	36	50°	30°	01:00	2/22	2/45	2/60	2/60
34	MILK	Milk case	34	40°	20°	01:00	4/20	4/45	2/60	2/60
35	PKDL	Packaged deli	32	38°	18°	01:00	4/20	4/45	2/60	2/60
36	DLDS	Deli display case	34	38°	18°	01:00	4/20	4/45	2/60	2/60
37	CHEZ	Cheese case	34	40°	20°	01:00	3/18	3/45	2/45	2/60
38	POBX	Poultry box	36	42°	22°	01:00	4/20	4/45	2/45	2/60
39	BEER	Beer/Beverage	34	44°	24°	01:00	2/18	2/45	2/45	2/60
40	BVCS	Beverage case	34	44°	24°	01:00	2/18	2/45	2/45	2/60
41	DLBX	Deli cooler box	36	46°	26°	01:00	3/18	3/45	2/45	2/60
42	FHBX	Fish cooler box	36	46°	26°	01:00	3/18	3/45	2/45	2/60

Table 8-7 - Case Type Default Settings

Type	Abbr.	Description	Set Point	High Alarm	Low Alarm	Delay	Defrost Type			
							Hot Gas	Elec. (DEF)	Rev. Air	Timed
43	SVDL	Service deli	32	42°	22°	01:00	2/16	2/45	2/60	1/40
44	PRCS	Produce case	35	45°	25°	01:00	2/16	2/45	2/60	3/40
45	ISPR	Produce case (island)	35	45°	25°	01:00	2/16	2/45	2/60	1/60
46	SALD	Salad table	36	50°	30°	01:00	2/16	2/45	2/60	1/60
47	FLBX	Flower cooler box	40	54°	34°	01:00	2/16	2/45	2/60	2/40
48	FLWR	Flower cooler	40	54°	34°	01:00	2/16	2/45	2/60	2/40
49	CTBX	Controlled temp box	50	75°	40°	00:15	2/16	2/45	2/60	2/45
50	SDPO	Single deck poultry	24	38°	18°	01:00	2/16	2/45	2/45	2/60
51	CAKE	Bakery cake case	40	55°	35°	01:00	2/16	2/45	2/45	2/60
52	BART	Bakery retarder	35	60°	40°	01:00	2/16	2/45	2/45	2/60
53	RTDR	Bakery retarder	35	60°	40°	01:00	2/16	2/45	2/45	2/60
54	MTPK	Meat packaging room	45	60°	40°	01:00	2/16	2/45	2/45	2/90
55	MTCU	Meat cutting room	45	60°	40°	01:00	2/16	2/45	2/45	2/90
56	MTPR	Meat prep room	45	60°	40°	01:00	2/16	2/45	2/45	2/90
57	MTWR	Meat wrapping room	45	60°	40°	01:00	2/16	2/45	2/45	2/90
58	FHPR	Fish prep room	45	60°	40°	01:00	2/16	2/45	2/45	2/90
59	SBCL	Subcooler	55	60°	45°	00:15	2/16	2/45	2/60	2/45
60	PRPR	Produce prep room	55	65°	45°	01:00	2/16	2/45	2/45	2/90
61	SDFM	Single deck freezer meat	-10	0°	-20°	01:00	2/18	2/40	1/35	1/45
62	RIFM	Reach-in freezer meat	-10	2°	-18°	01:00	2/18	2/40	1/35	1/45
63	MDFM	Multi-deck freezer meat	-10	0°	-20°	01:00	2/18	2/40	2/60	2/45
64	BKFZ	Bakery freezer box	-12	-2°	-22°	01:00	2/18	2/30	2/60	2/45

Revisions

- Added Board Number and Connected field information in **Section 7.3.1, Screen 1: General**.
- Updated 40-character limit to 63-character limit in the Long Name description in **Section 7.3.1, Screen 1: General**.

*For more product information,
scan the QR Code:*



Visit our website at copeland.com/en-us/products/controls-monitoring-systems for the latest technical documentation and updates.
For Technical Support call **833-409-7505** or email ColdChain.TechnicalServices@Copeland.com

The contents of this publication are presented for informational purposes only and they are not to be construed as warranties or guarantees, express or implied, regarding the products or services described herein or their use or applicability. Copeland reserves the right to modify the designs or specifications of such products at any time without notice. Responsibility for proper selection, use and maintenance of any product remains solely with the purchaser and end-user.
©2024 Copeland is a trademark of Copeland LP.