

# Programmable Touchscreen Thermostat Setup in E2 and Site Supervisor

## Quick Start Guide

The Emerson Programmable Touchscreen Thermostat (P/N 810-1600) is a configurable device intended for light commercial applications. The thermostat is a communicating, intelligent sensor and controller combination with built-in temperature and humidity sensors used to control systems such as conventional Rooftop Units (RTU) and Heat Pumps (HP). The thermostat communicates over a Modbus RTU network that easily integrates with a building management system (BMS). For more information, download the full user manual (P/N 026-1739) here:

<https://climate.emerson.com/documents/026-1739-emerson-programmable-touchscreen-thermostat-installation-operation-manual-en-5390496.pdf>

### Thermostat Installation and Mounting

To open the thermostat enclosure, grip the top and the bottom edge of the front part of the device and pull straight. A certain physical resistance is normal from the 24x contacts pins (terminal strips and terminal blocks) that have to be separated during the operation.

To close the thermostat enclosure, make sure to align the top and the bottom tabs between the front part and the baseplate, and then push the front part firmly toward the wall. Again, some force is required to mate both parts.

**Note that both top and bottom securing screws are optional and normally not installed on the units.**

To fix the baseplate on a wall, pass the wires through the opening of the baseplate, and use either 2x self-taping screws and dry-wall anchors, or regular 6-32 machine screws to attach on a standard single-gang electrical junction box (2" x 4").

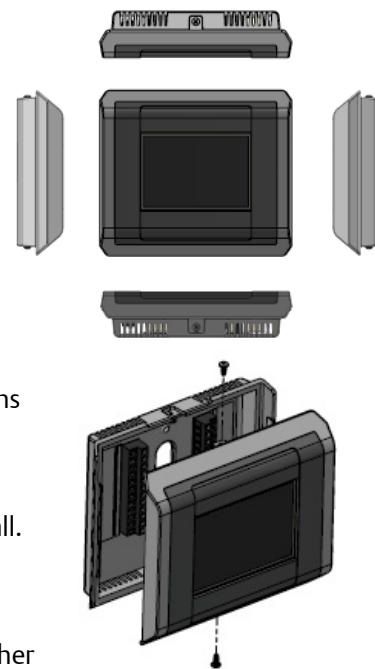

**CAUTION!** Do not over-tighten the screws when attaching the baseplate on a wall as physical damage may occur.

Keep the thermostat housing and vents clean and free of any debris to avoid malfunction of the device.

#### The thermostat should be mounted:

- > About 5 ft (1.5 m) from the floor.
- > On a part of wall without hidden pipes or ductwork.
- > In a room that operating limits are within 32°F to 122°F (0°C to 50°C).
- > In a room that humidity operating range is within 0% to 95% relative humidity, non-condensing.

#### The thermostat should not be mounted:

- > Nearby a window, on an outside wall, or next to a door leading to the outside.
- > Where exposed to direct light and heat from any heat source, such as a lamp, the sun, a fireplace, or any heating element which may cause a false reading (temperature measurement offset).
- > Nearby a direct airflow from supply registers (air vent or duct outlet).
- > In areas and locations with poor air circulation such as behind a door.

## Thermostat Wiring and Connections

Once the baseplate is affixed on the wall, proceed with the wiring connections to the terminal block.

Thermostat Power		Thermostat Communication	
R	24VAC Power Supply	B+	RS-485 + Signal
Rc	24VAC Power Supply for Y1, Y2	A-	RS-485 - Signal
C	24VAC Power Supply Common	GND	Ground Reference for DC signals

*Thermostat Power and Communication Matrix*

2H / 2C System with 1 Transformer		2H / 2C System with 2 Transformers		Heat Pump Systems	
R	24VAC Power Supply	R	24VAC Power Supply	R	24VAC Power Supply
Rc	24VAC Power Supply for Y1, Y2	Rc	24VAC Power Supply for Y1, Y2	Rc	24VAC Power Supply for Y1, Y2
C	24VAC Power Supply Common	C	24VAC Power Supply Common	C	24VAC Power Supply Common
Y1	Cool Stage 1, relay output	Y1	Cool Stage 1, relay output	Y1	*Cool Stage 1, relay output
Y2	Cool Stage 2, relay output	Y2	Cool Stage 2, relay output	Y2	*Cool Stage 2, relay output
W1	Heat Stage 1, relay output	W1	Heat Stage 1, relay output	O/B	Reversing Valve, relay output
W2	Heat Stage 2, relay output	W2	Heat Stage 2, relay output	G	Fan Control, relay output
G	Fan Control, relay output	G	Fan Control, relay output		

*Wiring and Connections*

*\*For systems with only one stage, the second stage terminals (Y2, W2) can be left floating open.*

## Setup and Configuration

On the first start-up of the thermostat, the default System Configuration is idle. This means that the first step to get the device started is to configure the appropriate system configuration. The following menu will appear by default upon the first startup:

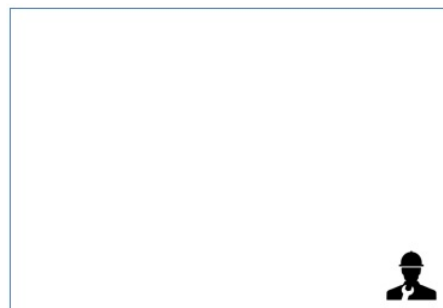

*Thermostat Display in Idle Configuration*

To access the Configuration Menu press the technician  icon for 10 seconds. If the thermostat has been previously configured, to access the configuration menu from the main display, a technician icon should be displayed on the right bottom corner of the screen. The technician icon is not displayed automatically. To display the technician icon, touch on the

right-bottom corner of the screen, and then press the technician icon  for 10 seconds.

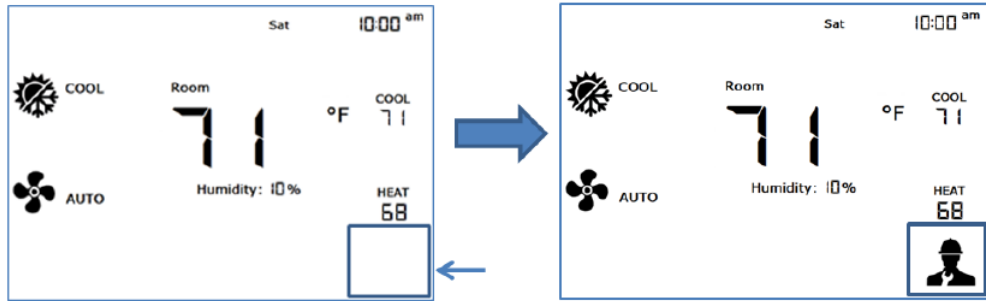

Configuration Menu Access

### Modbus Device Address

The first configuration menu allows users to change the Modbus device address. **Ad** is shown on the right side of the display to indicate which parameter is being changed (**Ad** stands for **Address**). To change the value, press either the up or down arrow, and then press the check icon to go to the next parameter. Press **CA** to cancel and exit the configuration menu without saving any changes. To change values, touch either the up or down arrow, and then touch the check icon to go to the next parameter.

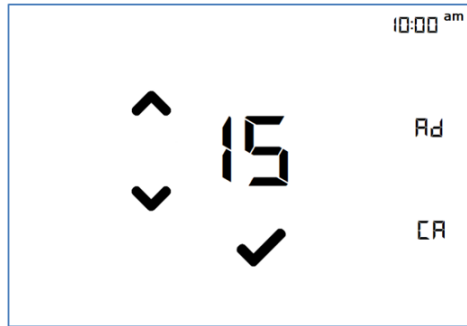

Modbus Address Configuration Menu

Address Number	Modbus Device Address
1 to 247	Range from 1 to 247

Modbus Device Address Range

### Modbus Device Baud Rate

The second configuration menu allows users to change the Modbus device baud rate. **br** is shown on the right side of the display to indicate which parameter is being changed (**br** stands for **Baud Rate**). To change the value, press either the up or down arrow, and then press the check icon to go to the next parameter. Press **CA** to cancel and exit the configuration menu without saving any changes.

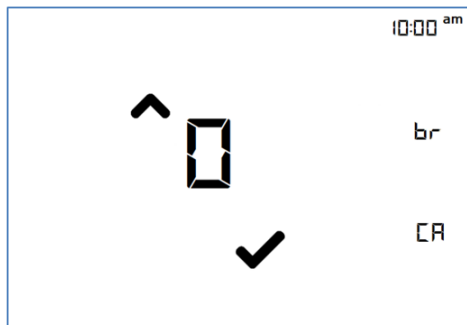

Modbus Rate Configuration Menu

Menu Option Number	Corresponding Baud Rate
0	9600 bps
1	19200 bps (default)

Modbus Baud Rate

### Thermostat System Configuration

The third configuration menu allows users to set the thermostat system configuration. **SC** is shown on the right side of the display to indicate which parameter is being changed (**SC** stands for **System Configuration**). The current revision of the Emerson Programmable Touchscreen Thermostat supports Conventional HVAC Systems such as RTU and Heat-pump Systems using a reversing valve. There are 4x possible configurations: IDLE, RTU, HP\_O and finally HP\_B. The first system configuration is IDLE. In this configuration, all the outputs of the thermostats are open and the thermostat controls are inactive. This is to prevent any issues within the current configuration compared to the equipment connected to the thermostat. To change the value, press either the up or down arrow, and then press the check icon to go to the next parameter. Press **CA** to cancel and return to the normal display without saving any changes.

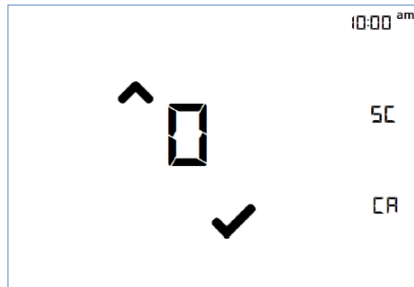

Thermostat System Configuration Menu

*NOTE: By default, the thermostat is configured as 2 heat-stages and 2 cool-stages thermostat. The number of heating/cooling stages can be changed in the subsequent menus.*

- When the system is not configured, for example, configured in IDLE, all other configurations are accessible through the menu as below:

Menu Option Number	Corresponding Baud Rate
0	IDLE
1	RTU (Conventional Systems)
2	*HP_O (Heat-pump with O as reversing signal)
3	*HP_B (Heat-pump with B as reversing signal)

Thermostat System Configuration



Configuration Menu with Options 0-IDLE, 1-RTU, 2-HP-O, 3-HP-B

- When the system is already configured in RTU, HP\_O or HP\_B, only the IDLE and the current configuration are accessible through the menu:

Menu Option Number	Corresponding Baud Rate
0	IDLE
(1, 2, or 3)	Current Configuration

*Thermostat System Configuration*

*IMPORTANT! In order to change the thermostat's configuration from a functional configuration (not IDLE) to another one, the thermostat must be set to IDLE configuration first, then all configuration options will be displayed on the screen and the new desired configuration can be chosen.*

*IMPORTANT! A factory reset of all parameters will occur when the system is set to the IDLE configuration, except current date and time that are kept with the use of a Real-Time Clock (RTC).*

### Number of Heating Stages

For all systems, the number of heating stages can be modified inside this menu. On the screen, the letters “**HS**” stands for **Heating Stages**. Possible values are 1 heating stage, 2 heating stages. Press the **Done** icon to move on to the next menu. Values will not be saved until the last configuration menu is reached.



*Number of Heating Stages is Set to 2 (Unsaved)*

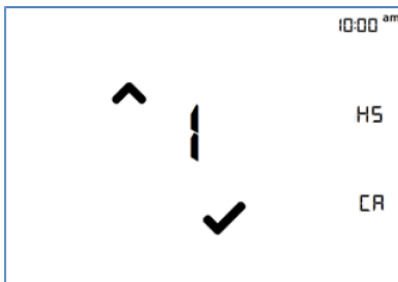

*Number of Heating Stages is Set to 1 (Unsaved)*

### Number of Cooling Stages

For all systems, the number of cooling stages can be modified inside this menu. On the screen, the letters “**CS**” stands for **Cooling Stages**. Possible values are 1 cooling stages, 2 cooling stages. Press the **Done** icon to move on to the next menu. Values will not be saved until the last configuration menu is reached.

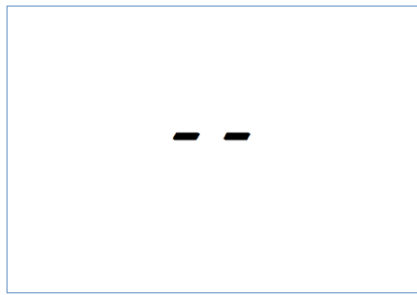

*Thermostat Display When Restarting Occurs (Rebooting)*



*System Configuration Menu (New System Configuration Mode After Idle)*

### Full Segments Display Test

The fourth configuration menu allows users to test the full display segments. This allows a complete review of the display segments and to inform the user of all possible segments in the current Emerson Programmable Touchscreen Thermostat revision. Press the check icon to go to the next parameter.

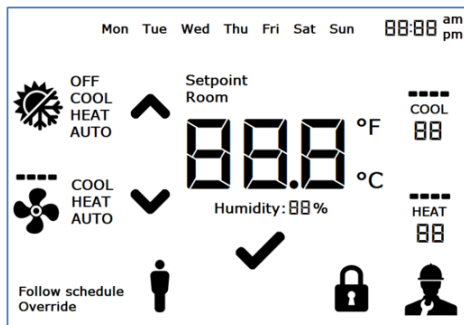

*Full Segments Display Test*

### System Revision Display

The fifth and last configuration menu provides the current system revision number. This number is shown with three digits. Note that there is no decimal after the first digit, but the revision number contains a decimal. For example, revision number 100 on the display = 1.00. The software revision will be updated for the latest official release, and will likely be higher than 1.00. Touch the letters “CA” to cancel any previous changes and go back to the normal display without saving. Press the check icon to terminate the configuration menus.



System Revision Display

*IMPORTANT! If at least one of those parameters has been changed, the thermostat will reboot: Thermostat system configuration, number of Heating stages or number of Cooling stages.*

Prior to device restart, the display will show “- -” to indicate that the device is about to reboot. When the device is rebooting, the display will turn off for approximately a few seconds until reboot operation has completed.

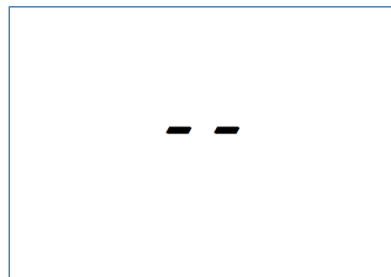

Thermostat Display Before Reboot

## E2

### New Installation and Uploading of Touch\_TStat Description File to E2

The Programmable Touchscreen Thermostat (P/N 810-1600) requires adding a description file (P/N 527-0729) to E2. Contact Customer Service to obtain this information: [Solutions.CustomerService@Emerson.com](mailto:Solutions.CustomerService@Emerson.com)

NOTE:  Software must be installed to perform a description file upload.

1. Connect to E2 using UltraSite32 (refer to the *UltraSite32 Manual P/N 026-1002*).
2. Launch the UltraSite program and log in.
3. Double-click to UltraSite to view **Directory Level** and **Site Level**.
4. Right-click on **Site Level** and click **Connect**.
5. Double-click on **Site Level** and locate the E2 Unit where the **Touch T-Stat.dsc** will be installed.
6. Right-click on the unit and select **Upload Description File**.
7. Click **Browse** and select the appropriate description (\*.dsc) file for **Touch T-Stat.dsc** from the computer and click **Open**.
8. Click **Upload**. A window will display that the description file was successfully imported. Click **OK**. The description (\*.dsc) file should appear in the list.
9. Once completed, disconnect from the E2 and reboot the E2 controller - either manually with the toggle switch or remotely through Terminal Mode.

*NOTE: DO NOT omit the step of rebooting the controller.*

# Device and COM Port Setup in E2

## Modbus Device Setup

The RS-485 line of the transmitter is isolated from the power supply. A separate ground reference terminal (GND) is provided for the RS-485 connection.

If you are using the shielded cable, the Shld terminal can be used to hold the exposed part of the shield. Note that the Shld terminal is floating (not electrically connected).

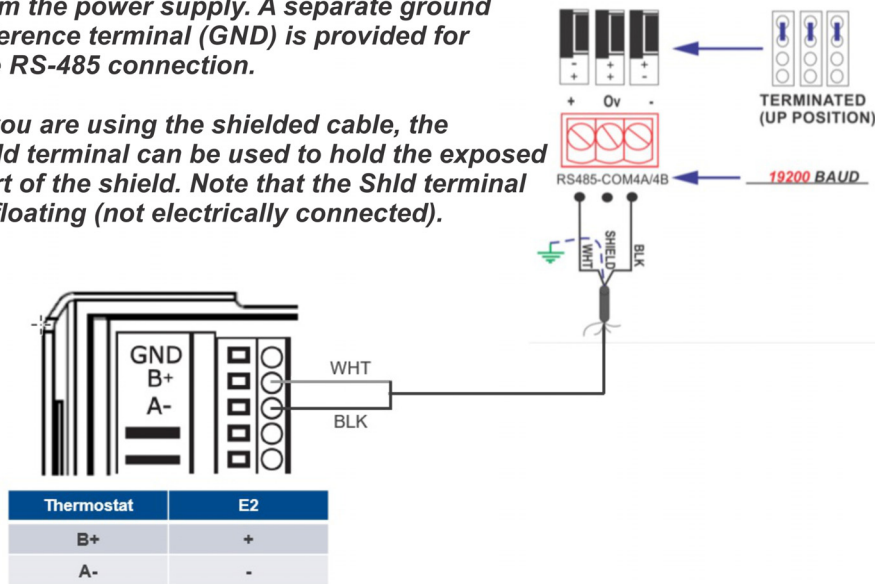

## E2 COM Port Setup

1. Log into the E2 by pressing
2. Press then , and to access General controller Info.
3. Press twice to move to **C3: Serial** tab.
4. Press the to select the Com Port that the device is wired to (**COM2**, **COM4** or **COM6**).
5. Press for **LOOK UP** and select **MODBUS-1**, **MODBUS-2** or **MODBUS-3**.
6. Press to set configuration.
7. Set the MODBUS connection as follows:
  - Press to select options and press to set the configuration.
    - > **Com Baud:** 19.2 Kbaud
    - > **Com Data Size:** 8
    - > **Com Parity:** None
    - > **Com Port Stop Bits:** 1
  - Press to set the configuration.
8. Press to save changes.
9. Press to return to the **Home** screen.



## Installing the Thermostat in E2

### Installing the Thermostat Application

1. Press **Menu**, **7**, **7**, **2** to enter **Connected I/O Boards and Controllers**.
2. Press **F2** once to move to **C3: ECT** tab. Highlight the application **Tch T-Stat** and enter the desired number of devices under **Quantity** up to **6**.

### Commissioning the Thermostat

1. Press **Menu**, **7**, **7**, **1** to enter the **Network Summary** screen.
2. Highlight the **Tch T-Stat001** to be commissioned by pressing the down arrow and then **F4**.
3. A window with **Select Network** appears on the screen, select the Modbus number where you configured the device and press **Enter**.
4. Select the address for the device and press **Enter**. Default for the device is **1**.
5. A window will appear. Press **Enter** and a confirmation will show **MODBUS Device Address is set**.

## Site Supervisor

### Device and COM Port Setup in Site Supervisor

#### Modbus Device Setup

The RS-485 line of the transmitter is isolated from the power supply. A separate ground reference terminal (GND) is provided for the RS-485 connection.

If you are using the shielded cable, the Shld terminal can be used to hold the exposed part of the shield. Note that the Shld terminal is floating (not electrically connected).

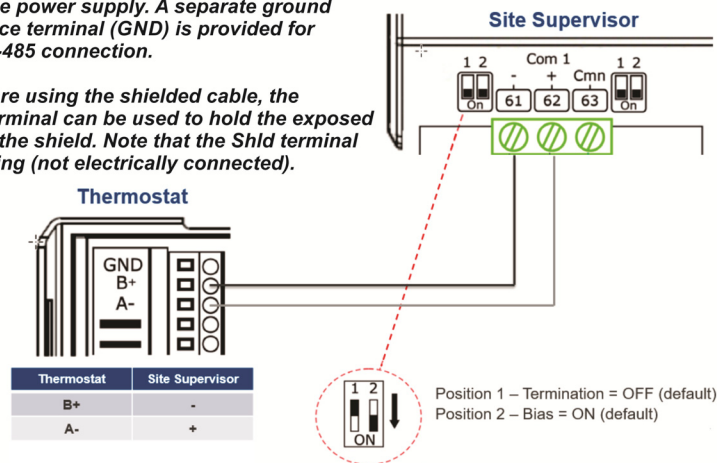

**NOTE:** The polarity of the MODBUS connection between Site Supervisor and Touchscreen Thermostat is reversed.

#### Site Supervisor COM Port Setup

1. Click the Settings icon (the gear) and select **General System Properties**.
2. Select the Com Port the device is wired to (**Com Port 1 - 4**).
3. Select the available Modbus (**Modbus-01 - Modbus-04**).
4. Set the Modbus connection as follows:
  - > **Com Port Baud:** 19.2 Kbaud
  - > **Com Port data size:** 8
  - > **Com Port Parity:** None
  - > **Com Port Stop Bits:** 1
5. Click **Save** to save the changes

# Installing the Thermostat in Site Supervisor

## Installing the Thermostat Application

1. Click the **Control Inventory** icon (the box) 
2. Expand the **HVAC** category and go to the **Add Control** drop-down list and select **Touch T-Stat**.

## Commissioning the Thermostat

1. Click the **Port ID** drop-down list to select Modbus assigned to the Com Port selected.
2. Click the **Address** drop-down list to select the Modbus Address (default address is 1).
3. Click the **Association** drop-down list to select the **HVACZone** to associate with the thermostat.
4. Click **Update** to save settings.
5. Wait a few seconds and the device should appear **Online**.
6. Click the name of the application to view the Status Screen.

Scan the QR code to download the full user manual P/N 026-1739



*This document may be photocopied for personal use.*

*Visit our website at <http://www.climate.emerson.com> for the latest technical documentation and updates.*

*Join Emerson Technical Support on Facebook <http://on.fb.me/WUQRnt>*

*For Technical Support call 770-425-2724 or email [ColdChain.TechnicalServices@Emerson.com](mailto:ColdChain.TechnicalServices@Emerson.com)*

The contents of this publication are presented for informational purposes only and they are not to be construed as warranties or guarantees, express or implied, regarding the products or services described herein or their use or applicability. Emerson Climate Technologies Retail Solutions, Inc. and/or its affiliates (collectively "Emerson"), reserves the right to modify the designs or specifications of such products at any time without notice. Emerson does not assume responsibility for the selection, use or maintenance of any product. Responsibility for proper selection, use and maintenance of any product remains solely with the purchaser and end-user.

Emerson is a trademark of Emerson Electric Co. ©2020 Emerson Climate Technologies Retail Solutions, Inc. All rights reserved.