



60Hz Water cooled semi-hermetic condensing units

Product catalogue

COPELAND™

EMERSON™

Water-cooled condensing units

General information

The WH range of water cooled condensing units are suitable for medium and low temperature refrigeration applications:

Medium Temperature	R134a
Low Temperature	R404a

The high side heat exchangers are specifically designed for chilled water loops.

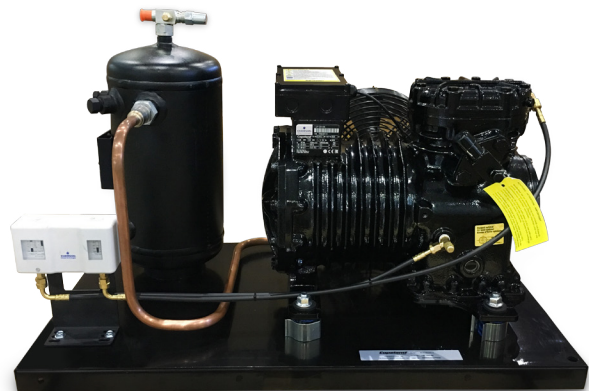

Features

Copeland semi-hermetic compressor

- Suction and discharge valves
- Oil sight Glass
- Mounting springs
- Motor protection by INT69 thermistor module
- Discharge vibration eliminator
- Side mounted compressor fan for optimal compressor cooling
- POE Oil
- Internal oil pump for enhanced lubrication
- External oil pump and OPS for 2D model

Compressor cooling fan, K and L model

- External rotor, axial fan with guard grill (Form V)
- 230V single phase
- Power / Current Input: 67 W / 0.46 A
- Fan pre-wired to compressor terminal box

Tube in Shell Hermetic Condenser

- Shell and connections : carbon steel
- Tube : copper
- Built in receiver
- Refrigerant side connections : rotalock type
- 1/2" NPT provision for safety relief valve
- Compliant to PED 97/23/EC Directive
- Maximum Pressure Limits
: Refrigerant side 30 bar
: Water side 10 bar

Accessories

- HP/LP dual pressure safety switch, auto reset

Capacity Data

- Units are rated at 30 °C Condensing, 3K Sub Cooling, 20°C Suction Gas Return, 7 °C Water Inlet Temperature

Nomenclature

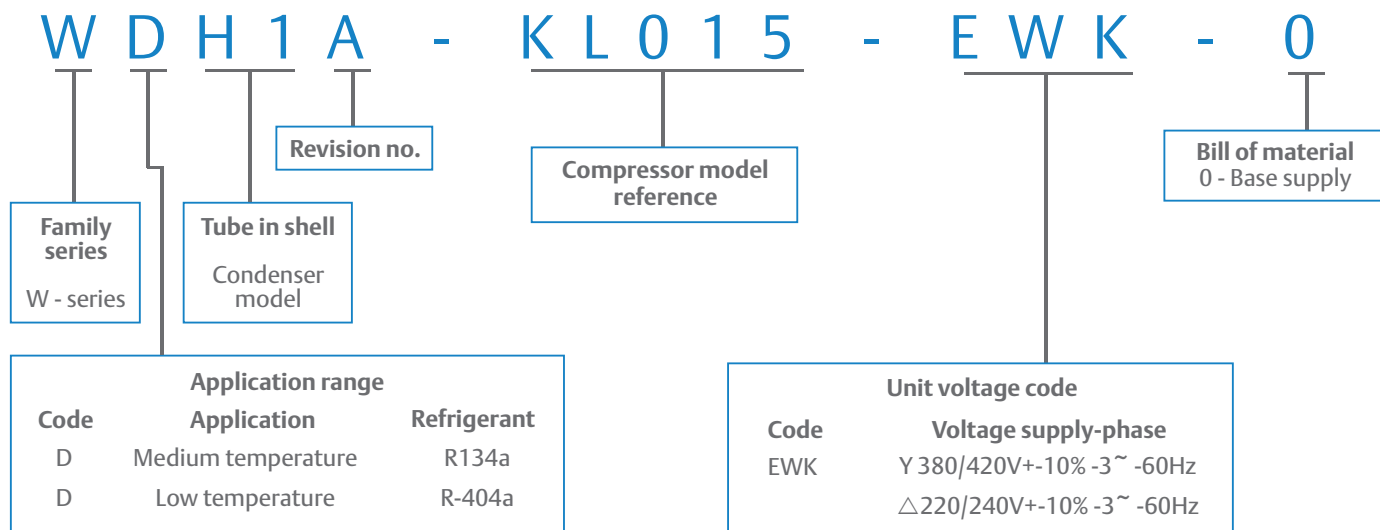

Performance data

Condensing Unit Model		R404a					R134a				
		Evaporating Temperature (°C)									
		-40	-35	-30	-25	-20	-15	-10	-5	0	5
WDH1A-KJ007-EWK	Capacity (kW)	0.88	1.21	1.60	2.07	2.61	1.76	2.25	2.82	3.48	4.26
	Power Input (kW)	0.78	0.86	0.94	1.01	1.08	0.69	0.73	0.77	0.79	0.79
	Flowrate (l/s)	0.03	0.04	0.05	0.06	0.07	0.04	0.06	0.07	0.09	0.11
	Pressure Drop (kPa)	0.14	0.22	0.37	0.56	0.93	0.33	0.51	0.86	1.38	2.12
WDH1A-SJ010-EWK	Capacity (kW)	1.18	1.59	2.07	2.63	3.29	2.15	2.73	3.41	4.20	5.13
	Power Input (kW)	1.00	1.11	1.21	1.32	1.42	0.84	0.90	0.95	0.97	0.98
	Flowrate (l/s)	0.04	0.05	0.06	0.08	0.10	0.06	0.07	0.09	0.12	0.15
	Pressure Drop (kPa)	0.22	0.37	0.62	1.07	1.73	0.51	0.86	1.38	2.22	3.62
WDH1A-KL015-EWK	Capacity (kW)	1.38	1.84	2.39	3.04	3.80	2.50	3.17	3.95	4.87	5.94
	Power Input (kW)	1.09	1.21	1.34	1.46	1.57	1.03	1.10	1.16	1.20	1.22
	Flowrate (l/s)	0.04	0.06	0.07	0.10	0.12	0.07	0.09	0.11	0.14	0.19
	Pressure Drop (kPa)	0.30	0.51	0.86	1.56	2.54	0.73	1.22	2.02	3.36	5.64
WDH2A-SL020-EWK	Capacity (kW)	1.70	2.29	2.99	3.82	4.80	3.17	4.02	5.03	6.21	7.59
	Power Input (kW)	1.25	1.45	1.66	1.86	2.06	1.26	1.37	1.47	1.54	1.59
	Flowrate (l/s)	0.04	0.06	0.08	0.10	0.13	0.07	0.09	0.12	0.16	0.20
	Pressure Drop (kPa)	0.41	0.70	1.24	2.15	3.56	1.07	1.71	2.87	4.79	7.95
WDH3A-LF020-EWK	Capacity (kW)	1.80	2.64	3.63	4.79	6.16	4.24	5.44	6.86	8.53	10.45
	Power Input (kW)	1.37	1.66	1.95	2.24	2.53	1.55	1.69	1.80	1.88	1.92
	Flowrate (l/s)	0.04	0.06	0.08	0.11	0.15	0.09	0.11	0.15	0.19	0.26
	Pressure Drop (kPa)	0.43	0.84	1.71	3.00	5.34	1.82	2.99	5.15	8.52	14.72
WDH3A-LJ020-EWK	Capacity (kW)	2.15	3.17	4.38	5.81	7.49	4.83	6.14	7.69	9.50	11.60
	Power Input (kW)	1.60	1.95	2.29	2.63	2.96	1.96	2.10	2.21	2.29	2.35
	Flowrate (l/s)	0.05	0.07	0.10	0.14	0.20	0.10	0.13	0.17	0.23	0.31
	Pressure Drop (kPa)	0.61	1.29	2.57	4.97	9.50	2.44	4.09	6.95	11.84	20.63
WDH4A-LL030-EWK	Capacity (kW)	2.97	4.26	5.78	7.58	9.68	6.09	7.83	9.88	12.25	15.05
	Power Input (kW)	2.04	2.46	2.87	3.28	3.68	2.35	2.55	2.73	2.87	2.97
	Flowrate (l/s)	0.06	0.09	0.12	0.16	0.22	0.11	0.14	0.19	0.24	0.32
	Pressure Drop (kPa)	1.25	2.47	4.66	8.26	14.49	3.86	6.46	10.85	18.17	30.54
WDH4A-DL040-EWK	Capacity (kW)	4.19	5.72	7.58	9.80	12.40	7.86	10.20	12.95	16.15	
	Power Input (kW)	2.73	3.20	3.66	4.10	4.52	2.83	3.04	3.19	3.28	
	Flowrate (l/s)	0.10	0.13	0.18	0.26	0.36	0.16	0.22	0.30	0.41	
	Pressure Drop (kPa)	3.40	6.30	11.20	20.70	38.80	8.90	15.30	27.30	49.40	
WDH5A-DB050-EWK	Capacity (kW)	5.10	6.93	9.20	11.95	15.15	9.84	12.65	16.00	19.90	24.50
	Power Input (kW)	3.19	3.75	4.34	4.91	5.44	3.25	3.52	3.72	3.84	3.87
	Flowrate (l/s)	0.11	0.15	0.20	0.27	0.36	0.19	0.24	0.32	0.42	0.55
	Pressure Drop (kPa)	1.20	2.10	3.60	6.30	10.70	3.20	5.20	8.50	14.00	23.10

Mechanical data

Condensing Unit Model	Compressor Model	Receiver Capacity (l)	Width/Depth [W/D] (mm)	Base Mounting Ø [b x t] (mm)	Height [H] (mm)	Suction Ø [SL] (")	Liquid Ø [LL] (")	Water Inlet (")	Water Outlet (")	Net Weight (kg)	Gross Weight (kg)
WDH1A-KJ007-EWK	KJ-7X-EWK	4.6	680/450	645 x 415 (14)	417	5/8	1/2	G 1/2	G 1/2	61	76
WDH1A-SJ010-EWK	KSJ-10X-EWK	4.6	680/450	645 x 415 (14)	417	5/8	1/2	G 1/2	G 1/2	61	76
WDH1A-KL015-EWK	KL-15X-EWK	4.6	680/450	645 x 415 (14)	417	5/8	1/2	G 1/2	G 1/2	61	76
WDH2A-SL020-EWK	KSL-20X-EWK	4.6	680/450	645 x 415 (14)	417	5/8	1/2	G 1/2	G 1/2	61	76
WDH3A-LF020-EWK	LF-20X-EWK	8.1	820/506	785 x 415 (14)	527	7/8	1/2	G 1/2	G 1/2	108	123
WDH3A-LJ020-EWK	LJ-20X-EWK	8.1	820/506	785 x 415 (14)	527	7/8	1/2	G 1/2	G 1/2	108	123
WDH4A-LL030-EWK	LL-30X-EWK	8.1	820/506	785 x 415 (14)	527	1 1/8	1/2	G 1/2	G 1/2	115	130
WDH4A-DL040-EWK	2DL-40X-EWK	8.1	1000/510	965 x 475 (14)	527	1 3/8	5/8	G 1/2	G 1/2	161	176
WDH5A-DB050-EWK	2DB-50X-EWK	19.0	1000/510	965 x 475 (14)	562	1 3/8	5/8	G 1 1/2	G 1 1/2	170	185

Electrical data

Condensing Unit Model	Compressor Model	Compressor Maximum Operating Current (A)	Compressor Locked Rotor Current (A)
WDH1A-KJ007-EWK	KJ-7X-EWK	2.9	16.7
WDH1A-SJ010-EWK	KSJ-10X-EWK	3.6	23.3
WDH1A-KL015-EWK	KL-15X-EWK	4.1	25.6
WDH2A-SL020-EWK	KSL-20X-EWK	5.6	26.7
WDH3A-LF020-EWK	LF-20X-EWK	6.6	48.5
WDH3A-LJ020-EWK	LJ-20X-EWK	6.7	48.5
WDH4A-LL030-EWK	LL-30X-EWK	8.8	69.5
WDH4A-DL040-EWK	2DL-40X-EWK	13.3	76.0
WDH5A-DB050-EWK	2DB-50X-EWK	16.1	76.0

Data valid for 380/420-3~60 Hz, Y connected compressor
 For 220/240-3~60 Hz, Δ connected compressor, multiply above values by 1.75

Dimensional drawing

WDH1, WDH2

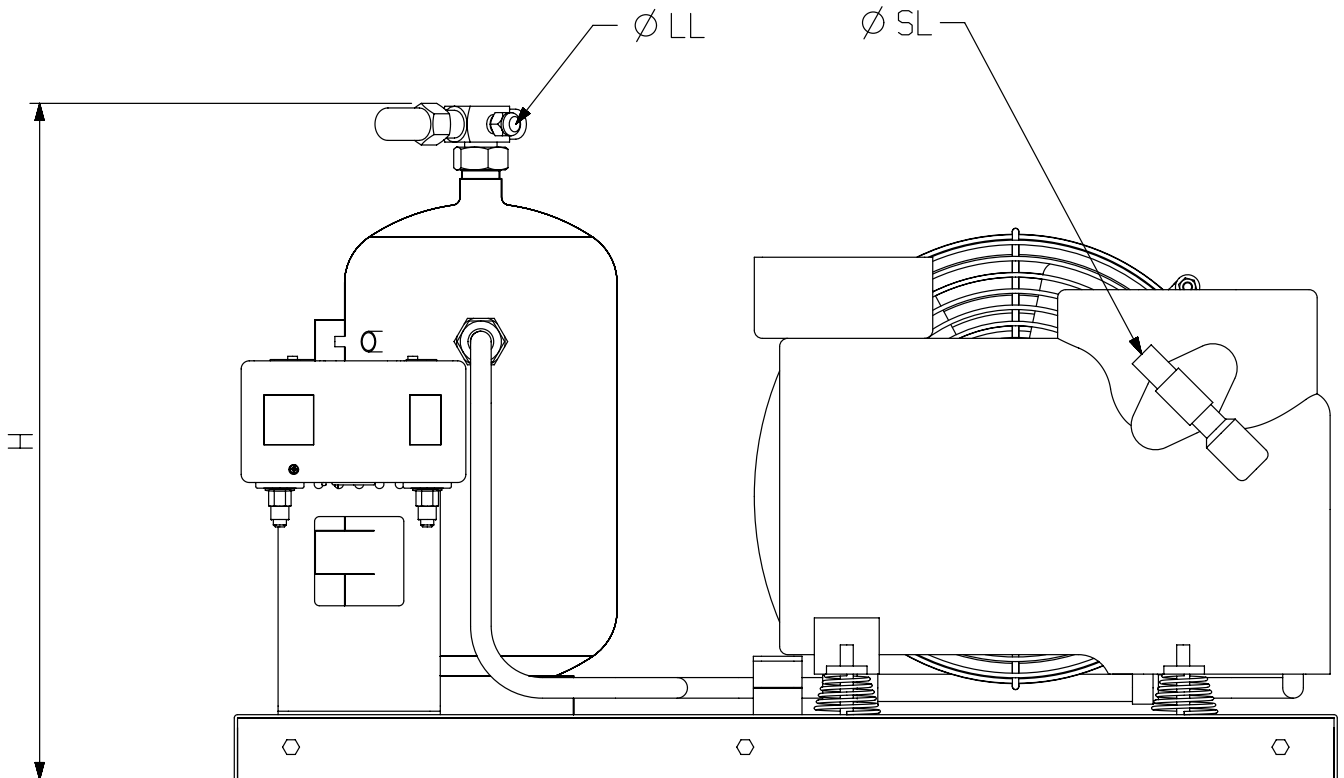
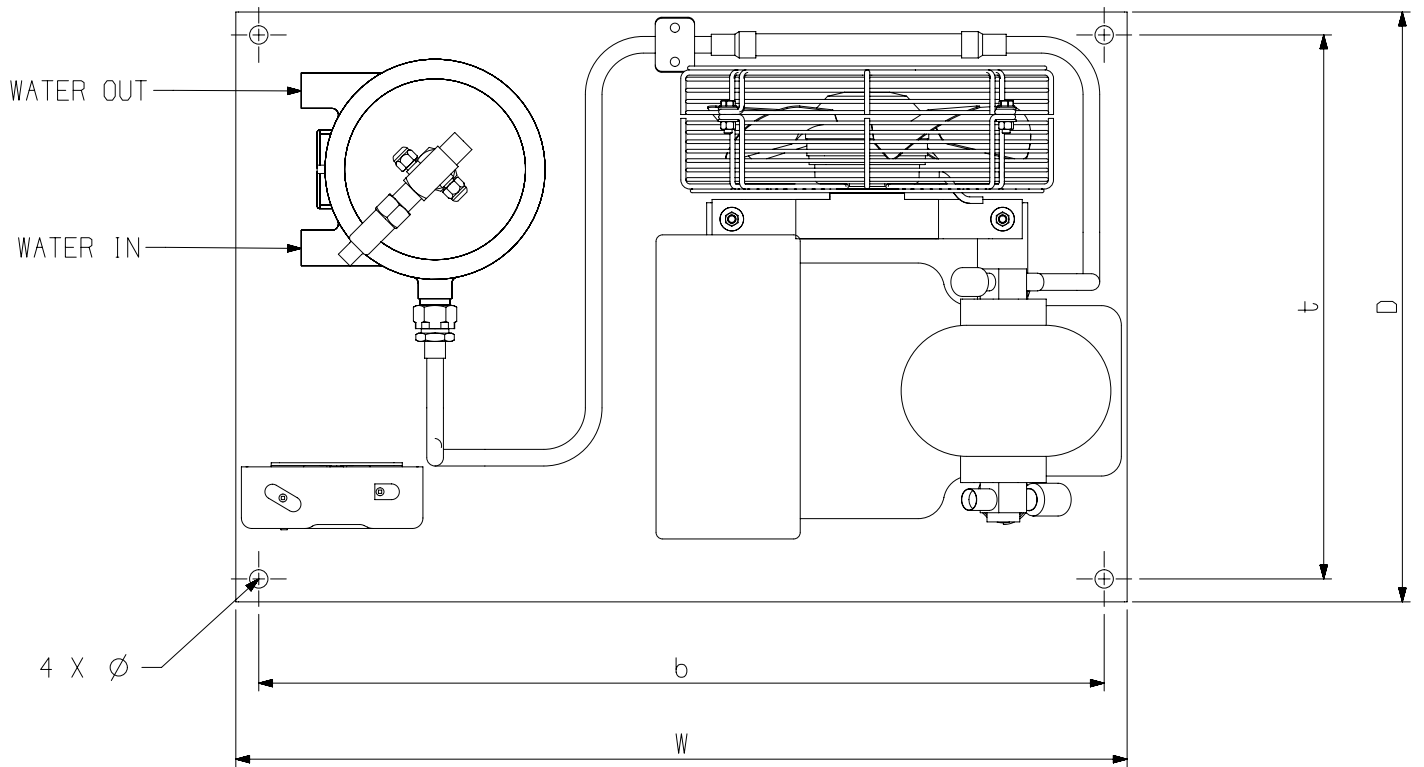

Dimensional drawing

WDH3, WDH4

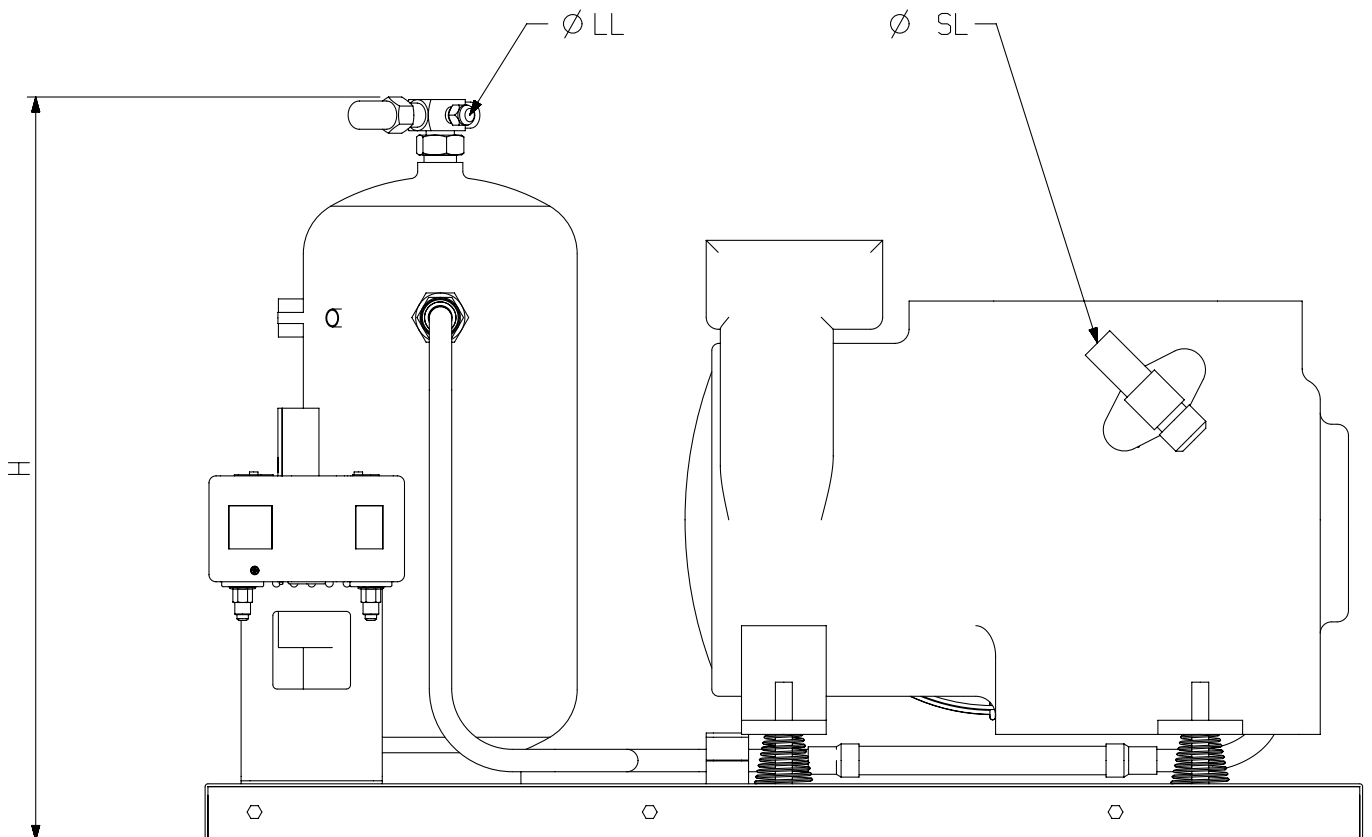
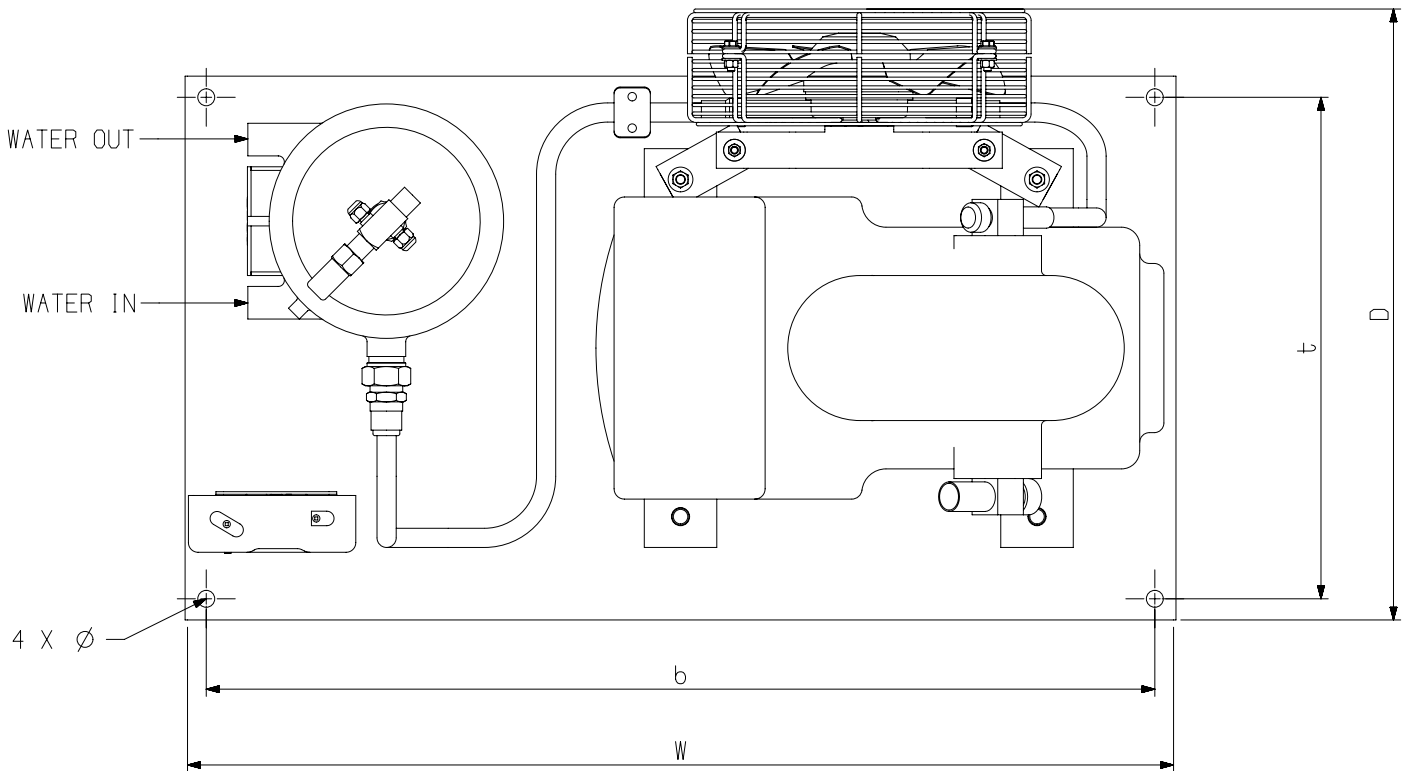

Dimensional drawing

WDH4-DL, WDH5

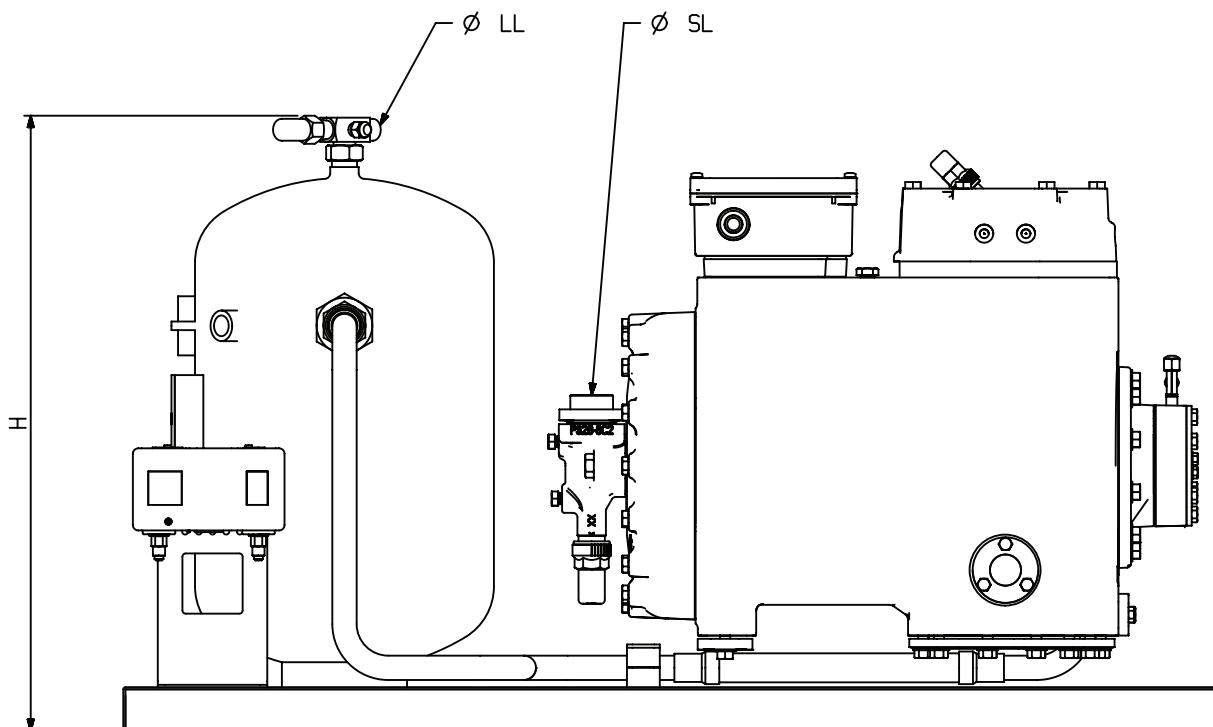
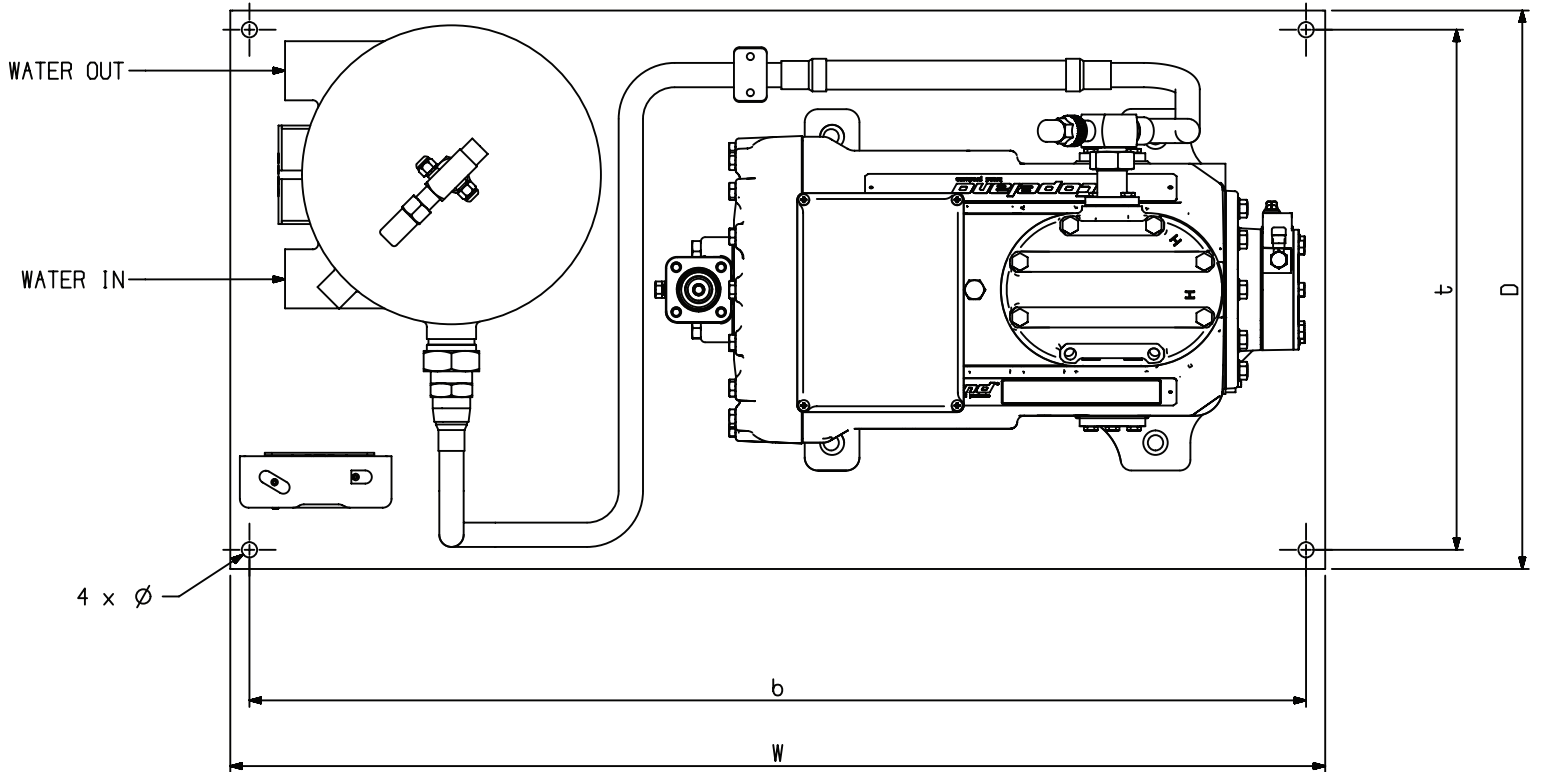

About Emerson

Emerson (NYSE: EMR), headquartered in St. Louis, Missouri (USA), is a global technology and engineering company providing innovative solutions for customers in industrial, commercial, and residential markets. Emerson Commercial and Residential Solutions business helps ensure human comfort and health, protect food quality and safety, advance energy efficiency, and create sustainable infrastructure. For more information visit www.Emerson.com.

Contact us

United Arab Emirates

Jebel Ali Free Zone
P.O. Box 26382, Dubai
United Arab Emirates
Toll Free: 8000 441 3428
Tel: +971 4 8118100
Fax: +971 4 8865465

Saudi Arabia

P.O. Box 34332 - 3620
2nd Industrial City, 67 St.
Dammam, Saudi Arabia
Toll Free: 8008 443 426
Tel: +966 3 8147560
Fax: +966 3 8147570

South Africa

11 Quark Crescent
Linbro Business Park
Sandton 2065, South Africa
Toll Free: 0800 980 3711
Tel: +27 11 451 3700
Fax: +27 11 451 3800

Egypt

P.O.Box 11799
11 & 12 / 1138 Mustafa
Refaat Street Sheraton,
Heliopolis Cairo, Egypt
Tel: +20 2 226 5854