

XR75CX

Digital Controller

For Medium-Low Temperature Refrigeration Applications



Copeland
1065 Big Shanty Road NW, Suite 100
Kennesaw, GA 30144 USA
770-425-2724 • 1-800-829-2724
www.copeland.com
Email: ColdChain.TechnicalServices@copeland.com

1 INTRODUCTION..... 1

1.1 General Warning..... 1

2 OVERVIEW..... 1

2.1 General Description..... 1

2.2 Ordering Code 1

3 CONTROLLING LOADS..... 2

3.1 Compressor..... 2

3.2 Defrost..... 2

3.3 Control of Evaporator Fans 2

 3.3.1 Forced Activation of Fans..... 2

 3.3.2 Cyclical Activation of the Fans With Compressor Off..... 2

3.4 Light Relay Configuration (PAR oA2; Terminals 1-2)..... 3

 3.4.1 Light Relay..... 3

 3.4.2 Auxiliary Relay - oA2=AUS..... 3

 3.4.3 On/Off Relay (oA2=onF) 3

 3.4.4 Neutral Zone Regulation..... 3

 3.4.5 Alarm Relay 3

 3.4.6 Night Blind Management During Energy Saving Cycles 3

4 FRONT PANEL COMMANDS..... 4

4.1 Keys and Functions 4

4.2 Use of LEDS 4

5 MAX AND MIN TEMPERATURE MEMORIZATION 5

5.1 How to See the MIN Temperature..... 5

5.2 How to See the MAX Temperature 5

5.3 How to Reset the Max and Min Temperature Recorded 5

6 MAIN FUNCTIONS..... 6

6.1 How to See the Setpoint..... 6

6.2 How to Change the Setpoint 6

6.3 How to Start a Manual Defrost 6

6.4 How to Change a Parameter Value..... 6

6.5 The Hidden Menu 6

 6.5.1 How to Enter the Hidden Menu 6

 6.5.2 How to Move a Parameter From the Hidden Menu To the First Level and Vice Versa 6

6.6 How to Assign a MODBUS Address..... 7

6.7 How to Lock the Keyboard..... 7

6.8 To Unlock the Keyboard 7

6.9 The Continuous Cycle 7

6.10 The ON/OFF Function 7

7 PARAMETERS 8

8 DIGITAL INPUTS..... 13

8.1 Generic Alarm (i2F=EAL)..... 13

8.2 Serious Alarm Mode (i2F=bAL) 13

8.3 Pressure Switch (i2F=PAL) 13

8.4 Door Switch Input (i1F or i2F=dor) 13

8.5 Start Defrost (i1F or i2F=dEF) 13

8.6 Switch the Auxiliary Relay (i2F=AUS)..... 13

8.7 Inversion of the Kind of Action: Heating - Cooling (i2F=Htr) 13

8.8 Energy Saving (i2F=ES) 13

8.9 ON - OFF Function (i2F=onF) 13

8.10 Digital Inputs Polarity 13

9 RS485 SERIAL LINE (FOR MONITORING SYSTEMS)..... 14

10 X-REP OUTPUT (OPTIONAL)..... 14

11 INSTALLATION AND MOUNTING 14

12 ELECTRICAL CONNECTIONS 15

12.1 Probe Connection..... 15

13 HOW TO USE THE HOT KEY 15

13.1 How to Program a Hot Key From the Controller (Upload) 15

13.2 How to Program the Controller Using a Hot Key (Download) 15

14 ALARM SIGNALS 16

14.1 Silencing Buzzer/Alarm Relay Output 16

14.2 Alarm Recovery..... 16

14.3 Other Messages..... 16

15 SPECIFICATIONS 17

16 CONNECTIONS..... 18

17 E2 MODBUS NETWORK WIRING..... 19

18 ECT MODBUS NETWORKING TO E2S 20

18.1 COM Port Associations - E2 Versions 3.xx and Below 20

18.2 COM Port Associations - E2 Versions 4.2 and Above 20

18.3 E2 Setup of Devices..... 21

 18.3.1 Set Up Network Ports..... 21

 18.3.2 Add and Connect the Device 21

18.4 Wiring Types..... 22

18.5 MODBUS Termination Blocks 23

19 DEFAULT SETTING VALUES 24

**APPENDIX A - ALTERNATE MODBUS COM WIRING METHOD FOR E2, XR, XM,
AND XEV DEVICES..... 28**

1 Introduction

1.1 General Warning

Please read the following safety precautions and warnings before using this product:

CAUTION

- This manual is part of the product and should be kept near the controller for easy and quick reference.
- The controller should not be used for purposes different from those described in this manual. It cannot be used as a safety device.
- Check the application limits before proceeding.

WARNING

- Check that the supply voltage is correct before connecting the controller.
- Do not expose to water or moisture: use the controller only within the operating limits and avoid sudden temperature changes with high atmospheric humidity to prevent condensation from forming.
- Warning! Disconnect all electrical connections before performing any kind of maintenance.
- Fit the probe where it is not accessible by the end user. The controller must not be opened.
- In case of failure or faulty operation, send the controller back to the distributor or to Copeland (see address) with a detailed description of the fault.
- Verify the maximum current that can be applied to each relay (see Section 15, Specifications).
- Ensure that the wires for probes, loads, and the power supply are separated and far enough from each other, without crossing or intertwining.
- In case of applications in industrial environments, the use of main filters (our mod. FT1) in parallel with inductive loads could be useful.

2 Overview

2.1 General Description

Model XR75CX (32 mm x 74 mm) is a microprocessor based controller, suitable for applications on medium or low temperature ventilated refrigeration units. It has four (4) relay outputs to control compressor, fan, and defrost, which can be either electrical or reverse cycle (hot gas) and light (configurable).

It can also have up to four (4) NTC (EU or US type) probe inputs. The first probe is used for temperature control. The second probe is used to control the defrost termination temperature at the evaporator. One of the two (2) digital inputs can operate as a third temperature probe. The fourth probe is used to control the condenser temperature (for condenser alarm management) or to display a temperature value. Set the **PbC** parameter to **CtC** to support standard CPC temperature sensors (factory default).

The RS-485 serial output enables the unit to be connected to a network line that is MODBUS-RTU compatible, such as the monitoring units of XWEB family. The Hot Key receptacle allows the controller to be programmed by means of the Hot Key programming keyboard.

The controller is fully configurable through special parameters that can be easily programmed through the keyboard.

2.2 Ordering Code

Table 2-1 - Product Ordering Code

Device Name	Code	Copeland Code
XR75CX - 110VAC	XR75CX-4C6F3B - X0LG3OEUB4NA-000	318-6030
XR75CX - 230VAC	XR75CX-5C6F3B - X0LG3OEUB5NA-000	318-6031

3 Controlling Loads

3.1 Compressor

The regulation is performed according to the temperature measured by the thermostat probe with a positive differential (**HY**) from the setpoint: if the temperature increases and reaches setpoint plus the differential, the compressor is started and then turned OFF when the temperature reaches the setpoint value again.

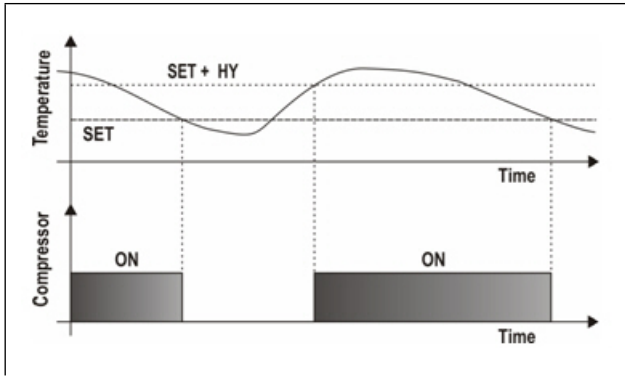

Figure 3-1 - Compressor Temperature Regulation

In case of a fault in the thermostat probe, the start and stop of the compressor are timed through parameters **Con** and **CoF**.

3.2 Defrost

Two defrost modes are available through the **tdF** parameter: defrost through electrical heater (**tdF=EL**) and hot gas defrost (**tdF=in**).

- **EdF=in**, the defrost is made every **idF** time (the standard method for the controller)

Other parameters are used to control defrost cycles: its maximum duration (**MdF**) and two defrost modes: timed or controlled by the evaporator's probe (**P2P**).

At the end of defrost dripping time is started, its duration is set in the **Fdt** parameter. With **Fdt=0**, the dripping time is disabled.

3.3 Control of Evaporator Fans

The fan control mode is selected by means of the **FnC** parameter:

- **FnC = C_n**: fans will switch ON and OFF with the compressor and not run during defrost.
- **FnC = O_n**: fans will run even if the compressor is OFF, and not run during defrost.

After defrost, there is a timed fan delay allowing for drip time, set by means of the **Fnd** parameter.

- **FnC = C_y**: fans will switch ON and OFF with the compressor and run during defrost.
- **FnC = O_y**: fans will run continuously during defrost also.

An additional parameter called **FSt** provides the setting of temperature, detected by the evaporator probe, above which the fans are always OFF. This is used to make sure that air is circulated only if this temperature is lower than set in **FSt**.

3.3.1 Forced Activation of Fans

Managed by the **Fct** parameter, this function is designed to avoid short cycles of fans that could occur when the controller is switched ON or after a defrost, when the room air warms the evaporator.

How it works: If the temperature difference between the evaporator probe and the room probe is higher than the **Fct** parameter value, the fans will be switched ON. When **Fct = 0**, the function will be disabled.

3.3.2 Cyclical Activation of the Fans With Compressor Off

When **FnC = C-n** or **C-y** (fans are working in parallel with the compressor), by means of the **Fon** and **FoF** parameters, the fans can carry out ON and OFF cycles even if the compressor is switched OFF. When the compressor is stopped, the fans will continue to work for the **Fon** time. With **Fon = 0**, the fans always remain OFF when the compressor is OFF.

3.4 Light Relay Configuration (PAR oA2; Terminals 1-2)

The functioning of the auxiliary relay (terminals 1-2) can be set by the **oA2** parameter, according to the kind of application needed. Possible settings are as follows:

3.4.1 Light Relay

When **oA2 = Lig**, the relay 1-2 operates as a light.

3.4.2 Auxiliary Relay – oA2=AUS

a. Relay Activation By Digital Input 2 (oA2 = AUS, i2F = AUS)

When **oA2 = AUS** and **i2F = AUS**, the relay 1-2 is switched ON and OFF by the digital input.

b. Auxiliary Thermostat

An anti-condensing heater with the possibility of switching it ON and OFF with the keyboard.

Parameters Involved

- **ACH** - The kind of regulation for the auxiliary relay. **Ht**: heating; **CL**: cooling
- **SAA** - Setpoint for auxiliary relay
- **SHY** - Differential for auxiliary relay
- **ArP** - Probe for auxiliary relay
- **Sdd** - Auxiliary output OFF during defrost

The differential is set by the **SHY** parameter.

NOTE

Set **oA2 = AUS** and **ArP = nP** (no probe for auxiliary output). In this case, the relay 1-2 can be activated only by the digital input with **i1F** or **i2F = AUS**.

3.4.3 On/Off Relay (oA2=onF)

When **oA2 = onF**, the relay is activated when the controller is turned ON and de-activated when the controller is turned OFF.

3.4.4 Neutral Zone Regulation

When **oA2 = db**, the relay 1-2 can control a heater element to perform a neutral zone action.

- **oA2** cut in = **SET-HY**
- **oA2** cut out = **SET**

3.4.5 Alarm Relay

When **oA2 = ALr**, the relay 1-2 operates as an alarm relay. It is activated every time an alarm occurs. Its status depends on the **tbA** parameter: if **tbA = y**, the relay is silenced by pressing any key. If **tbA = n**, the alarm relay remains ON until the alarm condition recovers.

3.4.6 Night Blind Management During Energy Saving Cycles

With **oA2 = HES**, the relay 1-2 operates to manage the night blind: the relay is powered when the energy saving cycle is activated by a digital input, front panel button.

4 Front Panel Commands



Figure 4-1 - XR75CX Front Panel

4.1 Keys and Functions

Table 4-1 shows the keys that are found on the front panel of the XR75CX controller and their corresponding functions:

Table 4-1 - XR75CX Front Panel Keys and Functions

Key	Function
SET	Press to display target setpoint, to select a parameter in programming mode, or to confirm an operation
	Starts a manual defrost
	Press the UP arrow key to see the MAX stored temperature, to browse the parameter codes in programming mode, or to increase the displayed temperature value.
	Press the DOWN arrow key to see the MIN temperature, to browse the parameter codes in programming mode, or to decrease the displayed temperature value.
	Switches the device ON and OFF, if oNF = oFF
	Switches the light ON and OFF, if oA1 = Lig
	Locks/Unlocks the keyboard
SET +	To enter programming mode
SET +	Returns to room temperature display

4.2 Use of LEDS

Each LED function is described in Table 4-2:

Table 4-2 - LEDS

LED	Mode	Function
	ON	Compressor enabled
	Flashing	Anti-short cycle delay enabled
	ON	Defrost enabled
	Flashing	Drip time in progress
	ON	Fans enabled
	Flashing	Fans delay after defrost in progress.
	ON	An alarm is occurring
	ON	Continuous cycle is running
	ON	Energy saving enabled
	ON	Light ON
AUX	ON	Auxiliary relay ON
°C,°F	ON	Measurement unit
	Flashing	Programming phase

5 *Max and Min Temperature Memorization*

5.1 How to See the MIN Temperature

1. Press and release the **DOWN** button.
2. The **Lo** message will be displayed followed by the minimum temperature recorded.
3. By pressing the **DOWN** button again or by waiting five seconds, the normal display will be restored.

5.2 How to See the MAX Temperature

1. Press and release the **UP** button.
2. The **Hi** message will be displayed followed by the maximum temperature recorded.
3. By pressing the **UP** button again or by waiting 5 seconds, the normal display will be restored.

5.3 How to Reset the Max and Min Temperature Recorded

1. Press and hold the **SET** button for more than 3 seconds while the max or min temperature is displayed (**rSt** message will be displayed).
2. After confirming the operation, the **rSt** message will start blinking and then the normal temperature will be displayed.

6 Main Functions

6.1 How to See the Setpoint

1. Press and immediately release the **SET** key; the display will show the setpoint value.
2. Press and immediately release the **SET** key or wait for 5 seconds to display the probe value again.



6.2 How to Change the Setpoint

1. Press and hold the **SET** button for more than 2 seconds to change the setpoint value.
2. The value of the setpoint will be displayed and the °C or °F LED will start blinking.
3. To change the setpoint value, press the **UP** or **DOWN** buttons within 10 seconds.
4. To memorize the new setpoint value, press the **SET** key again or wait 10 seconds.

6.3 How to Start a Manual Defrost

Press and hold the **DEF** key for more than 2 seconds and a manual defrost will start.



6.4 How to Change a Parameter Value

To change a parameter value, follow these steps:

1. Enter the Programming mode by pressing the **SET + DOWN** buttons for 3 seconds (the °C or °F LED will start blinking).
2. Select the required parameter. Press the **SET** button to display its value.
3. Use the **UP** or **DOWN** buttons to change its value.
4. Press **SET** to store the new value and move to the next parameter.

To exit: Press the **SET + UP** buttons or wait 15 seconds without pressing a key.

NOTE

The set value is stored even when the time-out expires and ends the procedure.

6.5 The Hidden Menu

The hidden menu includes all the parameters of the controller.

6.5.1 How to Enter the Hidden Menu

1. Enter the Programming mode by pressing the **SET + DOWN** buttons for three (3) seconds (the °C or °F LED will start blinking).
2. Release the buttons and then push the **SET + DOWN** buttons for more than seven (7) seconds. The **Pr2** label will be displayed immediately followed by the **HY** parameter: *You can now browse the Hidden Menu.*
3. Select the required parameter.
4. Press the **SET** button to display its value.
5. Use the **UP** or **DOWN** buttons to change its value.
6. Press **SET** to store the new value and move to the next parameter.

To exit: Press **SET + DOWN** or wait 15 seconds without pressing a key.

NOTE

If no parameter is present in Pr1 menu, after three (3) seconds the noP message is displayed. Keep the keys pressed until the Pr2 message is displayed.

NOTE

The set value is stored even when the time-out expires and ends the procedure.

6.5.2 How to Move a Parameter From the Hidden Menu To the First Level and Vice Versa

Each parameter present in the **Hidden Menu (Pr2)** can be moved into the user level (**Pr1**) by pressing **SET + DOWN** buttons. If a parameter is part of the user level, when it appears in the **Hidden Menu**, the decimal point will be illuminated.

6.6 How to Assign a MODBUS Address

1. Follow steps 1 and 2 of **Section 6.5.1, How to Enter the Hidden Menu** to access the Hidden Menu.
2. Select the **Adr** parameter.
3. Press **SET** to select.
4. Choose the address number using the buttons and press **SET** again to save.
5. Press **SET** and **UP** buttons to exit.

Note that devices cannot have duplicate addresses on the network. Assigning MODBUS addresses prior to terminating the network and leaving the address of device 1 as unused until the network is connected can prevent duplicate addressing network issues.

6.7 How to Lock the Keyboard

1. Keep the **UP + DOWN** buttons pressed for more than 3 seconds.
2. The **PoF** message will be displayed and the keyboard will be locked. At this point it will be possible to see the setpoint or the MAX or Min temperature stored only.
3. If a button is pressed for more than 3 seconds the **PoF** message will be displayed.

6.8 To Unlock the Keyboard

Press and hold the **UP** and **DOWN** buttons for more than 3 seconds until the **Pon** message displays.

6.9 The Continuous Cycle

When a defrost is not in progress, it can be activated by pressing and holding the **UP** button for about 3 seconds. The compressor operates to maintain the **CCS** setpoint for the time set through the **CCt** parameter. The cycle can be terminated before the end of the set time using the same activation button (UP button for 3 seconds).

6.10 The ON/OFF Function

When **onF = oFF**, pressing the **ON/OFF** key will switch OFF the controller. The **OFF** message is displayed. In this configuration, the regulation is disabled.

To switch the controller ON, press the **ON/OFF** key again.



WARNING Loads connected to the normally closed contacts of the relays are always supplied and under voltage (powered up), even if the device is in stand-by mode

7 Parameters

Table 7-1 - List of Parameters

Code	Parameter	Function
REGULATION		
HY	Differential	(0.1 to 25.5°C; 1 to 45°F) Intervention differential for setpoint. Compressor Cut IN is Set Point + differential (HY). Compressor Cut OUT is when the temperature reaches the setpoint.
LS	Minimum setpoint	(-50°C to SET; -58°F to SET) Sets the minimum value for the setpoint.
US	Maximum setpoint	(SET to 110°C; SET to 230°F) Sets the maximum value for setpoint.
ot	Thermostat probe calibration	(-12.0 to 12.0°C; -21 to 21°F) Allows to adjust possible offset of the thermostat probe.
P2P	Evaporator probe presence	(n; Y) n = not present, the defrost stops by time; Y = present, the defrost stops by temperature.
oE	Evaporator probe calibration	(-12.0 to 12.0°C; -21 to 21°F) Allows to adjust possible offset of the evaporator probe.
P3P	Third probe presence (P3)	(n; Y) n = not present, the terminals 18-20 operate as digital input; Y = present, the terminals 18-20 operate as third probe.
o3	Third probe calibration (P3)	(-12.0 to 12.0°C; -21 to 21°F) Allows to adjust possible offset of the third probe.
P4P	Fourth probe presence	(n; Y) n = Not present; Y = present
o4	Fourth probe calibration	(-12.0 to 12.0°C; -21 to 21°F) Allows to adjust possible offset of the fourth probe.
odS	Outputs activation delay at start up	(0 to 255min) This function is enabled at the initial start up of the instrument and inhibits any output activation for the period of time set in the parameter.
AC	Anti-short cycle delay	(0 to 50min) Minimum interval between the compressor stop and the following restart.
rtr	Percentage of the second and first probe for regulation	(0 to 100; 100=P1, 0=P2) Allows to set the regulation according to the percentage of the first and second probe, as for the following formula ($rtr(P1 - P2) / 100 + P2$).
CCt	Compressor ON time during continuous cycle	(0.0 to 24h00min, res. 10min) Allows to set the length of the continuous cycle. Compressor stays ON without interruption during CCt time. This is useful, for instance, when the room is filled with new products.
CCS	Setpoint for continuous cycle	(-50 to 110°C; (-58 to 230°F) Sets the setpoint used during the continuous cycle.
Con	Compressor ON time with faulty probe	(0 to 255min) Time during which the compressor is active in case of faulty thermostat probe. With Con=0 compressor is always OFF.
CoF	Compressor OFF time with faulty probe	(0 to 255min) Time during which the compressor is OFF in case of faulty thermostat probe. With CoF=0 compressor is always active.

Table 7-1 - List of Parameters

Code	Parameter	Function
DISPLAY		
CF	Temperature measurement unit	(°C; °F) °C = Celsius; °F = Fahrenheit. CAUTION: When the measurement unit is changed the SET point and the values of the parameters HY, LS, US, ot, ALU and ALL have to be checked and modified (if necessary).
rES	Resolution (for °C)	(in=1°C; dE=0.1°C) Allows decimal point display.
Lod	Instrument display	(P1; P2, P3, P4, SET, dtr) Selects which probe is displayed by the instrument. P1 = Thermostat probe; P2 = Evaporator probe; P3 = Third probe (only for model with this option enabled); P4 = Fourth probe, SET = setpoint; dtr = percentage of visualization.
rEd	X-REP display (optional)	(P1; P2, P3, P4, SET, dtr) Selects which probe is displayed by X- REP. P1 = Thermostat probe; P2 = Evaporator probe; P3 = Third probe (only for model with this option enabled); P4 = Fourth probe, SET = setpoint; dtr = percentage of visualization.
dLY	Display delay	(0 to 20min00s; res. 10s) When the temperature increases, the display is updated of 1°C or 1°F after this time.
dtr	Percentage of the second and first probe for visualization when Lod=dtr	(0 to 99; 100=P1, 0=P2) If Lod=dtr , it allows to set the visualization according to the percentage of the first and second probe, as for the following formula $(dtr(P1-P2)/100 + P2)$.
DEFROST		
tdF	Defrost type	(EL; in) EL = electrical heater; in = hot gas
dFP	Probe selection for defrost termination	(nP; P1; P2; P3; P4) nP = no probe; P1 = thermostat probe; P2 = evaporator probe; P3 = configurable probe; P4 = Probe on Hot Key plug
dtE	Defrost termination temperature	(-50 to 50°C; -58 to 122°F) (enabled only when EdF=Pb) Sets the temperature measured by the evaporator probe, which causes the end of defrost.
idF	Interval between defrost cycles	(0 to 120hours) Determines the interval of time between two defrost cycles.
MdF	(Maximum) length for defrost	(0 to 255min) When P2P=n , (not evaporator probe: timed defrost) it sets the defrost duration. When P2P=Y (defrost end based on temperature) it sets the maximum length for defrost.
dSd	Start defrost delay	(0 to 99min) This is useful when different defrost start times are necessary to avoid overloading the plant.
dFd	Temperature displayed during defrost	(rt; it; SEt; dEF) rt = real temperature; it = temperature at defrost start; SEt = setpoint; dEF = "dEF" label.
dAd	MAX display delay after defrost	(0 to 255min) Sets the maximum time between the end of defrost and the restarting of the real room temperature display.
Fdt	Drip time	(0 to 120min) Time interval between reaching defrost termination temperature and the restoring of the control's normal operation. This time allows the evaporator to eliminate water drops that might have formed due to defrost.
dPo	First defrost after start-up	(n; Y) n = after the idF time, Y = immediately
dAF	Defrost delay after continuous cycle	(0.0 to 24h00min, res. 10min) Time interval between the end of the fast freezing cycle and the following defrost related to it.

Table 7-1 - List of Parameters

Code	Parameter	Function
FANS		
FnC	Fans operating mode	(C-n; o-n; C-Y; o-Y) C-n = runs with the compressor, OFF during defrost; o-n = continuous mode, OFF during defrost; C-Y = runs with the compressor, ON during defrost; o-Y = continuous mode, ON during defrost.
Fnd	Fans delay after defrost	(0 to 255min) Interval between end of defrost and evaporator fans start.
Fct	Temperature differential to avoid fan short cycles	(0 to 59°C; 0 to 90°F) (N.B.: if Fct=0 function disabled) If the difference of temperature between the evaporator and the room probes is higher than Fct value, the fans will be switched ON.
FSt	Fans stop temperature	(-50 to 50°C; -58 to 122°F) Setting of temperature, detected by evaporator probe, above which fans are always OFF.
Fon	Fan ON time	(0 to 15min) With FnC=C_n or C_Y , (fan activated in parallel with compressor) it sets the evaporator fan ON cycling time when the compressor is OFF. With Fon=0 and FoF≠0 the fan are always OFF, with Fon=0 and FoF=0 the fan are always OFF.
FoF	Fan OFF time	(0 to 15min) With FnC=C_n or C_Y , (fan activated in parallel with compressor) it sets the evaporator fan OFF cycling time when the compressor is OFF. With Fon=0 and FoF≠0 the fan are always OFF, with Fon=0 and FoF=0 the fan are always OFF.
FAP	Probe selection for fan management	(nP; P1; P2; P3; P4) nP = no probe; P1 = thermostat probe; P2 = evaporator probe; P3 =configurable probe; P4 = Probe on Hot Key plug.
AUXILIARY THERMOSTAT CONFIGURATION (terms. 1-2) - oA2 = AUS		
ACH	Kind of regulation for auxiliary relay	(Ht; CL) Ht = heating; CL = cooling
SAA	Set Point for auxiliary relay	(-50 to 110.0°C; -58 to 230°F) It defines the room temperature setpoint to switch auxiliary relay.
SHY	Differential for auxiliary output	(0.1 to 25.5°C; 1 to 45°F) Intervention differential for auxiliary output setpoint. ACH=CL , AUX Cut in is [SAA+SHY]; AUX Cut out is SAA . ACH=Ht , AUX Cut in is [SAA-SHY]; AUX Cut out is SAA .
ArP	Probe selection for auxiliary	(nP; P1; P2; P3; P4) nP = no probe, the auxiliary relay is switched only by the digital input; P1 = Probe 1 (Thermostat probe); P2 = Probe 2 (evaporator probe); P3 = Probe 3 (display probe); P4 = Probe 4
Sdd	Auxiliary relay OFF during defrost	(n; Y) n = the auxiliary relay operates during defrost; Y = the auxiliary relay is switched OFF during defrost
ALARMS		
ALP	Probe selection for alarm	(nP; P1; P2; P3; P4) nP = no probe, the temperature alarms are disabled; P1 = Probe 1 (Thermostat probe); P2 = Probe 2 (evaporator probe); P3 = Probe 3 (display probe); P4 = Fourth probe
ALC	Temperature alarms configuration	(Ab; rE) Ab = absolute temperature, alarm temperature is given by the ALL or ALU values. rE = temperature alarms are referred to the setpoint. Temperature alarm is enabled when the temperature exceeds the [SET+ALU] or [SET-ALL] values.
ALU	MAXIMUM temperature alarm	(ALL to 110°C; ALL to 230°F) When this temperature is reached the alarm is enabled, after the ALd delay time.

Table 7-1 - List of Parameters

Code	Parameter	Function
ALL	Minimum temperature alarm	(-50°C to ALU; -58 to ALU) When this temperature is reached the alarm is enabled, after the ALd delay time.
AFH	Differential for temperature alarm recovery	(0.1 to 25.5°C; 1 to 45°F) Intervention differential for recovery of temperature alarm
ALd	Temperature alarm delay	(0 to 255 min) Time interval between the detection of an alarm condition and alarm signaling.
dAo	Exclusion of temperature alarm at start-up	(0.0 to 24h00min, res. 10min) Time interval between the detection of the temperature alarm condition after instrument power ON and alarm signaling.
CONDENSER TEMPERATURE ALARM		
AP2	Probe selection for temperature alarm of condenser	(nP; P1; P2; P3; P4) nP = no probe; P1 = thermostat probe; P2 = evaporator probe; P3 =configurable probe; P4 = Probe on Hot Key plug
AL2	Low temperature alarm of condenser	(-50 to 110°C; -58 to 230°F) When this temperature is reached the LA2 alarm is signalled, possibly after the Ad2 delay.
Au2	High temperature alarm of condenser	(-50 to 110°C; -58 to 230°F) When this temperature is reached the HA2 alarm is signalled, possibly after the Ad2 delay.
AH2	Differential for temperature condenser alarm recovery	(0.1 to 25.5°C; 1 to 45°F)
Ad2	Condenser temperature alarm delay	(0 to 255 min) Time interval between the detection of the condenser alarm condition and alarm signaling.
dA2	Condenser temperature alarm exclusion at start up	(0.0 to 24h00min, res. 10min)
bLL	Compressor OFF with low temperature alarm of condenser	(n; Y) n = no: compressor keeps on working; Y = yes, compressor is switched OFF until the alarm is present, in any case regulation restarts after AC time at minimum.
AC2	Compressor OFF with high temperature alarm of condenser	(n; Y) n = no: compressor keeps on working; Y = yes, compressor is switched OFF until the alarm is present, in any case regulation restarts after AC time at minimum.
AUXILIARY RELAY		
tbA	Alarm relay silencing (with oA2 =ALr)	(n; Y) n = silencing disabled: alarm relay stays ON until alarm condition lasts; Y =silencing enabled: alarm relay is switched OFF by pressing a key during an alarm.
oA2	Second relay configuration (1-2)	(dEF; FAn; ALr; LiG; AUS; onF; db; CP2; dEF2; HES) dEF = defrost; FAn = do not select it; ALr = alarm; LiG = light; AUS = Auxiliary relay; onF = always ON with instrument ON; db = neutral zone; CP2 = do not select it; dEF2 = do not select it; HES = night blind
AoP	Alarm relay polarity	(CL; oP) it set if the alarm relay is open or closed when an alarm occurs. CL = terminals 1-2 closed during an alarm; oP = terminals 1-2 open during an alarm.
DIGITAL INPUTS		
i1P	Digital input polarity (18-20)	(oP; CL) oP = the digital input is activated by opening the contact; CL = the digital input is activated by closing the contact

Table 7-1 - List of Parameters

Code	Parameter	Function
i1F	Digital input configuration (18-20)	(dor; dEF) dor = door switch function; dEF = activation of a defrost cycle
i2P	Second digital input polarity (18-19)	(oP; CL) oP = the digital input is activated by opening the contact; CL = the digital input is activated by closing the contact
i2F	Second digital input configuration (18-19)	(EAL; bAL; PAL; dor; dEF; ES; AUS; Htr; FAn; HdF; onF) EAL = external alarm: "EA" message is displayed; bAL = serious alarm "CA" message is displayed; PAL = pressure switch alarm, "CA" message is displayed; dor = door switch function; dEF = activation of a defrost cycle; ES = energy saving; AUS = auxiliary relay activation with oA2=AUS ; Htr = type of inverting action (cooling or heating); FAn = fan; onF = to switch the controller OFF
did	Digital input alarm delay (18-20) when i2F=EAL or i2F=bAL	(0 to 255 min) Delay between the detection of the external alarm condition and its signaling. When i2F= PAL , it is the interval of time to calculate the number of pressure switch activation
doA	Door open signaling delay	(0 to 255 min)
nPS	Number of pressure switch activation	(0 to 15) Number of activation, during the did interval, before signaling an alarm event (i2F=PAL). If the nPS activation during did time is reached, switch OFF and ON the instrument to restart normal regulation.
odc	Fan/compressor status when door open	(no; FAn; CP;F_C;) - no = normal; FAn = fan OFF; CP = compressor OFF, F_C = fan and compressor OFF
rrd	Outputs restart after doA alarm	(n; Y) n = outputs not affected by the doA alarm; Y = outputs restart with the doA alarm
HES	Delta temperature during an Energy Saving cycle	(-30.0 to 30.0°C; -54 to 54°F) Sets the increasing value of the setpoint [SET+HES] during the Energy Saving cycle.
OTHER		
Adr	Serial address	(1 to 247) Identifies the instrument address when connected to a MODBUS compatible monitoring system.
PbC	Type of probe	(ntC, CtC) It allows to set the kind of probe used by the instrument: ntC = NTC-EU probe, CtC = NTC-US probe. Set this PbC parameter to CtC to support standard CPC temp sensors - factory default.
onF	ON/OFF key enabling	(nU; oFF; ES) nU = disabled; oFF = enabled; ES = not set it
dP1	Thermostat probe display	
dP2	Evaporator probe display	
dP3	Third probe display (optional)	
dP4	Fourth probe display	
rSE	Real setpoint	Shows the setpoint used during the energy saving cycle or during the continuous cycle.
rEL	Software release for internal use	
Ptb	Parameter table code	Read only

8 Digital Inputs

The first digital input 18-20 is enabled with **P3P = n**. With **P3P = n** and **i1F = i2F**, the second digital input is disabled. The free voltage digital inputs are programmable by the **i1F** and **i2F** parameters.

8.1 Generic Alarm (i2F=EAL)

As soon as the digital input is activated the unit will wait for **did** time delay before signaling the **EAL** alarm message. The outputs status don't change. The alarm stops just after the digital input is de-activated.

8.2 Serious Alarm Mode (i2F=bAL)

When the digital input is activated, the unit will wait for **did** delay before signaling the **CA** alarm message. The relay outputs are switched OFF. The alarm will stop as soon as the digital input is deactivated.

8.3 Pressure Switch (i2F=PAL)

If the pressure switch has reached the number of activations (cycles) of the **nPS** parameter during the interval time set by the **did** parameter, the **CA** pressure alarm message will be displayed. The compressor and the regulation are stopped. When the digital input is ON the compressor is always OFF.

*If the **nPS** activation in the **did** time is reached, switch the controller OFF and ON to restart normal regulation.*

8.4 Door Switch Input (i1F or i2F=dor)

This input signals the door status and the corresponding relay output status through the **odc** parameter: **no** = normal (any change); **Fan** = Fan OFF; **CPr** = Compressor OFF; **F_C** = Compressor and fan OFF. Since the door is opened, after the delay time set through parameter **doA**, the door alarm is enabled, the display shows the message **dA**, and the regulation restarts is **rtr=Y**. The alarm stops as soon as the external digital input is disabled again. With the door open, the high and low temperature alarms are disabled.

8.5 Start Defrost (i1F or i2F=dEF)

A defrost will start if the right conditions exist. After the defrost is finished, normal regulation will restart only if the digital input is disabled; otherwise, the controller will wait until the **MdF** safety time is expired.

8.6 Switch the Auxiliary Relay (i2F=AUS)

When **oA2 = AUS**, the digital input switches the status of the auxiliary relay.

8.7 Inversion of the Kind of Action: Heating - Cooling (i2F=Htr)

This function allows to invert the regulation of the controller: from cooling to heating and vice versa.

8.8 Energy Saving (i2F=ES)

The Energy Saving function allows the setpoint value to be changed as the result of the **[SET+ HES]** (parameter) sum. This function is enabled until the digital input is activated.

8.9 ON - OFF Function (i2F=onF)

Switches the controller ON and OFF.

8.10 Digital Inputs Polarity

The digital input polarity depends on the **i1P** and **i2P** parameters.

- **i1P or i2P = CL**: the input is activated by closing the contact.
- **i1P or i2P = OP**: the input is activated by opening the contact

9 RS485 Serial Line (For Monitoring Systems)

The RS485 serial line allows the controller to connect to a monitoring system (MODBUS-RTU compatible) such as the X-WEB500/3000/300.

10 X-REP Output (Optional)

Optionally, an X-REP can be connected to the controller through the dedicated connector.

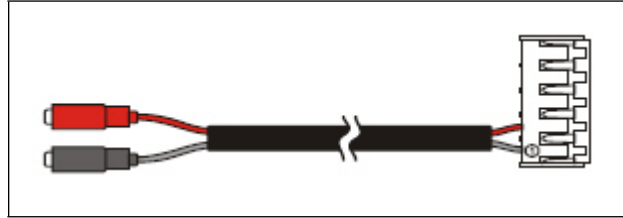

Figure 10-1 - X-REP Output

To connect the X-REP to the controller, the following connectors must be used: CAB-51F(1m), CAB-52F (2m), CAB-55F (5m).

11 Installation and Mounting

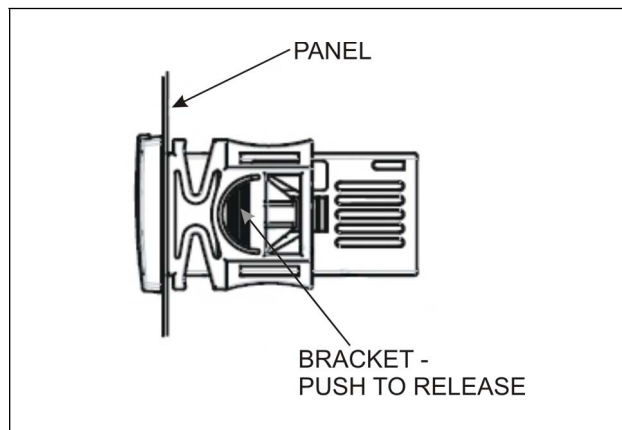

Figure 11-1 - Installation and Mounting of XR75CX

The XR75CX controller should be mounted on a vertical panel, in a 29 mm x71 mm hole, and secured using the special bracket supplied.

The temperature range allowed for correct operation is 0 to 60°C. Avoid places subject to strong vibrations, corrosive gases, excessive dirt, or humidity. The same recommendations apply to probes. Allow air to circulate through the cooling holes.

12 Electrical Connections

The device is provided with screw terminal block to connect cables with a cross section up to 2.5 mm². Before connecting cables verify that the power supply complies with the device's requirements. Separate the probe cables from the power supply cables, from the outputs and the power connections. Do not exceed the maximum current allowed on each relay, in case of heavier loads use a suitable external relay.

12.1 Probe Connection

The probes should be mounted with the bulb upwards to prevent damages due to casual liquid infiltration. It is recommended the thermostat probe be placed away from air streams to measure the average room temperature correctly. Place the defrost termination probe among the evaporator fans in the coldest place, (where most ice is formed) and far from heaters or from the warmest place during defrost to prevent premature defrost termination.

13 How to Use the Hot Key

13.1 How to Program a Hot Key From the Controller (Upload)

1. Program one controller using the front keypad.
2. When the controller is **ON**, insert the Hot Key into the 5-pin receptacle and push the up arrow button; the **uPL** message appears followed by a flashing **End** LED.
3. Push the **SET** button and **End** will stop flashing to indicate the upload has been successful.
4. Turn **OFF** the controller, remove the Hot Key, then turn it **ON** again

NOTE

The Err message is displayed in case of an error or failure in programming. In this case, push the UP button again if you want to restart the upload or remove the Hot Key to abort the operation.

13.2 How to Program the Controller Using a Hot Key (Download)

1. Turn **OFF** the controller by pressing the on/off button  for 5 seconds. **OFF** will display.
2. Insert a programmed Hot Key into the 5-pin receptacle and then turn the Controller **ON** by pressing the on/off button again for 5 seconds. The normal temperature value will display to indicate the controller is **ON**.
3. Automatically, the parameter list of the Hot Key is downloaded into the controller memory; the **doL** message will display followed by **End** at the end of the data transfer phase if the controller is programmed correctly.
4. After 10 seconds the controller will restart and work with the new parameters.
5. Remove the Hot Key.

NOTE

The Err message is displayed in case of an error or failure in programming. In this case turn the unit **OFF** and then **ON** if you want to restart the download again or remove the Hot Key to abort the operation.

14 Alarm Signals

Table 14-1 - Alarm Signals

Message	Cause	Outputs
P1	Room probe failure	Compressor output acc. to par. Con and CoF
P2	Evaporator probe failure	Defrost end is timed
P3	Third probe failure	Outputs unchanged
P4	Fourth probe failure	Outputs unchanged
HA	Maximum temperature alarm	Outputs unchanged.
LA	Minimum temperature alarm	Outputs unchanged.
HA2	Condenser high temperature	It depends on the AC2 parameter
LA2	Condenser low temperature	It depends on the bLL parameter
dA	Door open	Compressor restarts
EA	External alarm	Output unchanged.
CA	Serious external alarm (i2F=bAL)	All outputs OFF.
CA	Pressure switch alarm (i2F=PAL)	All outputs OFF
rtF	Real time clock board failure	Alarm output ON; Other outputs unchanged; Defrosts according to par. idF . Contact the service.

14.1 Silencing Buzzer/Alarm Relay Output

If **tbA = Y**, the buzzer and the relay are silenced by pressing any key.

If **tbA = n**, only the buzzer is silenced while the alarm relay is ON until the alarm condition recovers.

14.2 Alarm Recovery

Probe alarms **P1**, **P2**, **P3**, and **P4** start some seconds after the fault in the related probe; they automatically stop some seconds after the probe restarts normal operation. Check connections before replacing the probe.

Temperature alarms **HA**, **LA**, **HA2**, and **LA2** automatically stop as soon as the temperature returns to normal values.

Alarms **EA** and **CA** (with **i1F = bAL**) recover as soon as the digital input is disabled.

Alarm **CA** (with **i1F = PAL**) recovers only by switching OFF and ON the device.

14.3 Other Messages

Table 14-2 - Additional Display Messages

Message	Output
Pon	Keyboard unlocked
PoF	Keyboard locked
noP	In programming mode: No parameter is present
	On the display or in dP2, dP3, dP4: The selected probe is not enabled

15 Specifications

Table 15-1 - XR75CX Technical Data

Dimensions	Case: Front: 32 mm x 74 mm Depth: 60 mm Panel Mount: 71 mm x 29 mm panel cut-out	
Housing	Self extinguishing ABS	
Protection	IP 20	
Frontal Protection	IP65	
Connections	Screw terminal block $\leq 2.5 \text{ mm}^2$ wiring	
Power Supply (depending on the model)	24VAC $\pm 10\%$ 230VAC $\pm 10\%$, 50/60Hz 110VAC $\pm 10\%$, 50/60Hz	
Power Absorption	3VA max	
Display	3 digits, red LED, 14.2 mm high	
Inputs	Up to four (4) NTC-EU or NTC-US probes Digital: free voltage contact	
Relay Outputs UL Ratings	Evaporator Fan: 120/240 V, 50/60 Hz, 1/4 HP, 30k cycles 125 V, 50/60 Hz, 1/3 HP, 6k cycles 250 V, 50/60 Hz, 1/2 HP, 30k cycles	Terminals 4 and 1
	Compressor: 120 V, 50/60 Hz, 1/4 HP, 30k cycles 240 V, 50/60 Hz, 1/2 HP, 30k cycles	Terminals 3 and 1
	AUX/Light: 120/240 V, 50/60 Hz, 5 A General Purpose, 6k cycles	Terminals 2 and 1
	Defrost N. O.: 120/240 V, 50/60 Hz, 10 A, Resistive, 30k cycles 120/240 V, 50/60 Hz, C300, Pilot Duty, 30k cycles	Terminals 7 and 1
	Defrost N.C.: 120/240 V, 50/60 Hz, 10 A, Resistive, 30k cycles 120/240 V, 50/60 Hz, C300, Pilot Duty, 30k cycles	Terminals 8 and 1
Data Storing	On the non-volatile memory (EEPROM)	
Internal Clock Back-up	24 hours	
Kind of Action	1B	
Pollution Degree	2	
Software Class	A	
Rated Impulsive Voltage	2500V	
Overvoltage Category	II	

Table 15-1 - XR75CX Technical Data

Temperatures	Operating: 0 to 55°C (32 to 131°F)
	Storage: -30 to 85°C (-22 to 185°F)
Relative Humidity	20 to 85% (no condensing)
Measuring and Regulation Range	NTC-EU probe (10k ± 1%, β=3435): -40 to 110°C (-40 to 230°F)
	NTC-US probe (xxk ± y%, β=????): -40 to 110°C (-40 to 230°F)
Resolution	0.1°C or 1°C or 1°F (selectable)
Accuracy (ambient temperature 25°C)	±0.7°C ± 1 digit

16 Connections

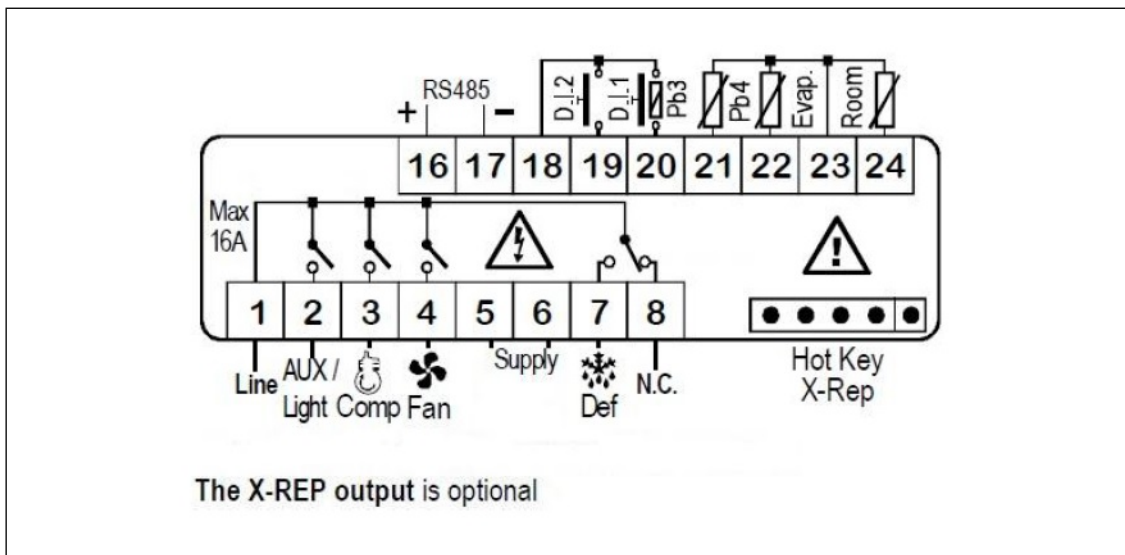

Figure 16-1 - XR75CX Connections

17 E2 MODBUS Network Wiring

- Connect the MODBUS Network to the RS485 Connector on the E2 PIB board (Belden 8641 recommended).
- Note to wire the RS485 +/- polarity at the E2 in the reverse of the XR75CX devices.
- Position the three termination jumpers to the UP (terminated) position to provide RS485 termination at the E2.
- Do not connect the shield of the MODBUS network to the E2 PIB center terminal. Instead, use a 100 ohm 1/2 watt resistor to connect the MODBUS cable shield to earth ground.
- At each XR75CX device, wire the MODBUS cable to the RS485 +/- terminals and connect the MODBUS shield to the pin **18** terminal.
- Terminate the end of the MODBUS network at the last XR75CX device on the daisy chain with the MODBUS termination block (P/N 535-2711), or by connecting a 150 ohm resistor between the MODBUS +/- terminals.

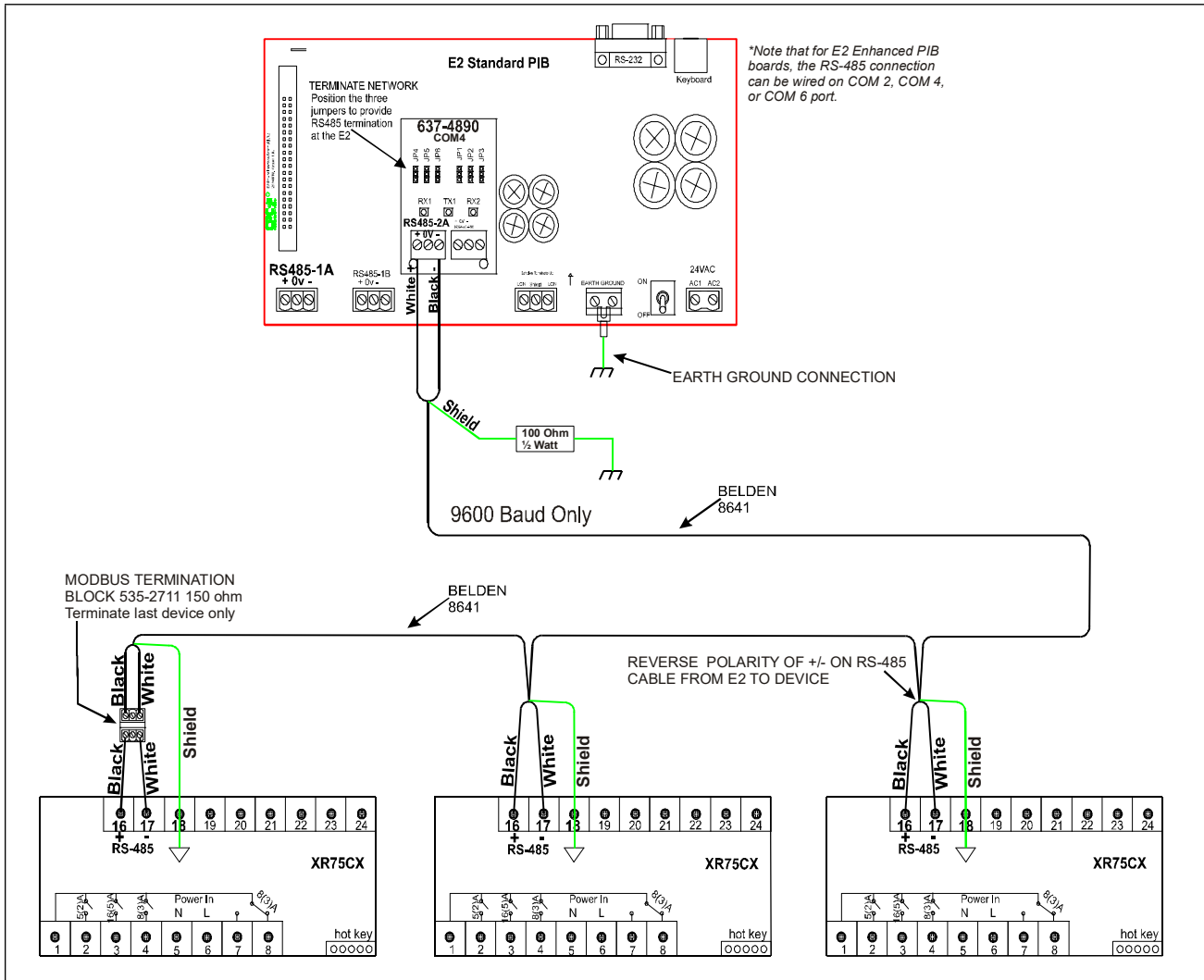

Figure 17-1 - XR75CX to E2 MODBUS Network Wiring

Refer to Appendix A - Alternate MODBUS COM Wiring Method for E2, XR, XM, and XEV Devices (Technical Bulletin P/N 026-4148).

18 ECT MODBUS Networking to E2s

18.1 COM Port Associations - E2 Versions 3.xx and Below

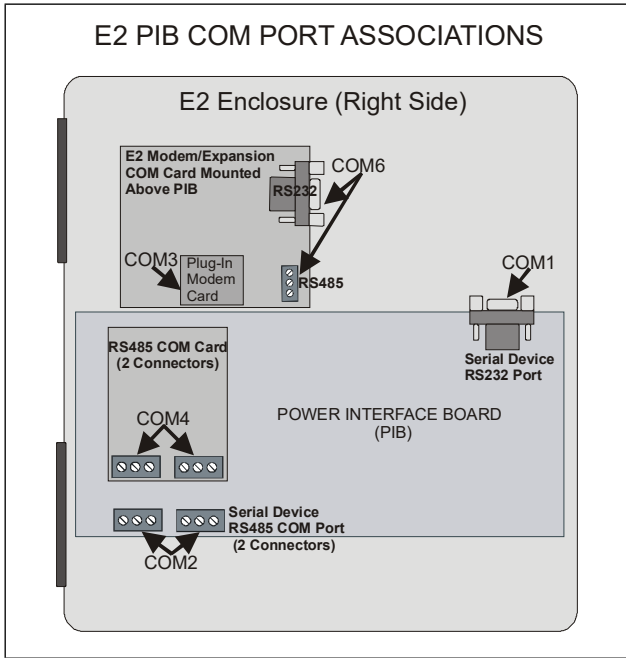

Figure 18-1 - Location of E2 COM Ports (E2 versions 3.xx and Below)

Connecting an XR75CX controller to an E2 requires the E2 to be version 2.84 or above. Contact Copeland for upgrade information if the controller is a version before 2.84.

An E2 has up to three COM ports that can be assigned for MODBUS communication: COM2, an RS485 port on the E2 power interface board, and COM4 and COM6, which are optional ports requiring expansion cards. COM4 is recommended for MODBUS connection of XR75CX units.

COM ports can only be used for one function; in other words, if COM2 is set up as the I/O network, you cannot connect MODBUS devices to COM2. Ensure your E2 is equipped with an RS485 COM Card (P/N 637-4890) and configured in E2 General Services (Menu **7 3 1**, **Serial** tab) to enable COM4 or an E2 Expansion COM Card (P/N 637-4871) to enable COM6.

Connect the MODBUS network cable to the three-terminal connector on the COM port you wish to assign as MODBUS. Reverse polarity of +/- on RS485 cable from E2 to the device.

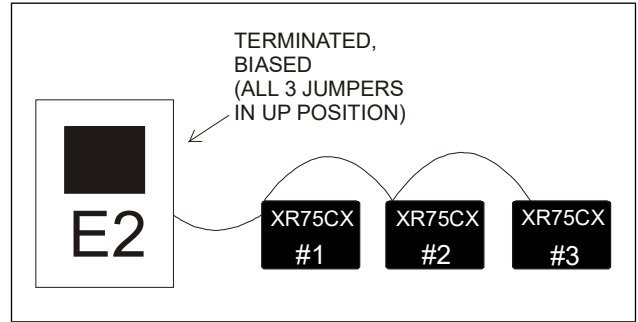

Figure 18-2 - MODBUS Networking

18.2 COM Port Associations - E2 Versions 4.2 and Above

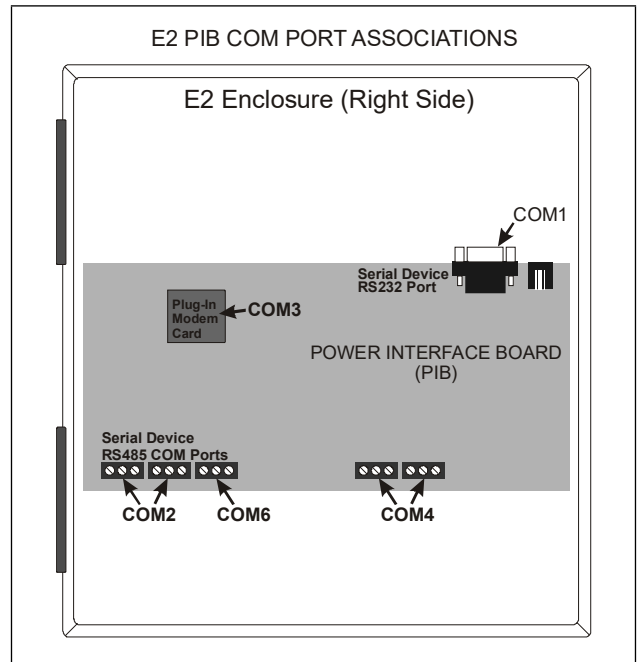

Figure 18-3 - Location of E2 COM Ports - E2 PIB Board (E2 versions 4.2 and above)

An E2 has three COM ports that can be assigned for MODBUS communication (COM2). COM ports can only be used for one function; in other words, if COM2 is set up as the I/O network, you cannot connect MODBUS devices to COM2. Ensure your E2 is configured in E2 General Services (Menu **7 3 1**, **Serial** tab) to enable COM4 or COM6.

18.3 E2 Setup of Devices

18.3.1 Set Up Network Ports

Before setting up a device, the port on the E2 that has the MODBUS cable connected must be set up as a MODBUS port.

1. Log in to the E2 with Level 4 access.
2. Press followed by - **General Controller Info**.
3. Press + to open the **Serial** tab of the General Controller Info setup screens:

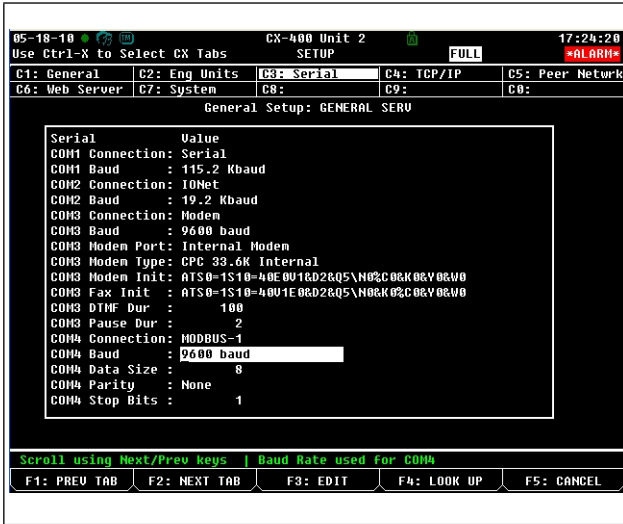

Figure 18-4 - Serial Communications Manager Screen

4. This screen will have a "Connection" field for all COM ports on the E2. Highlight the COM port connection field that will be used for the device, and press - **LOOK UP**. From the list of network types, select **MODBUS**.
5. Four fields will become visible underneath the COM port connection field, which pertain to the way the device communicates:

- **Baud** - Default setting is **19.2k**. The baud rate setting should be set to match the baud rate of the XR75CX device (9600). (All devices connected to the same COM port should be set to the same baud rate.)
- **Data Size** - Leave this field at the default value (**8**).
- **Parity** - Leave this field at the default value (**None**).
- **Stop Bits** - Leave this field at the default value (**1**).

6. Press to save changes and exit.

18.3.2 Add and Connect the Device

To enable communications between E2 and the XR75CX units, the devices must be added and addressed in E2.

1. Log in to the E2 with Level 4 access.
2. Press - **Connected I/O Boards and Controllers**.

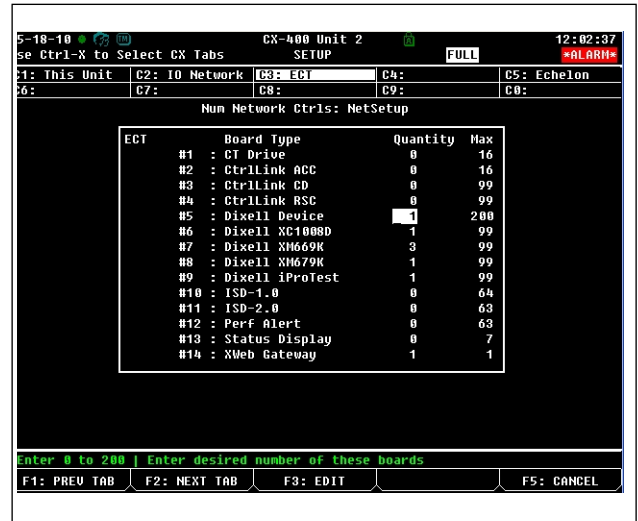

Figure 18-5 - Num NetworkCtrls: NetSetup Screen

3. In the **Num NetworkCtrls: NetSetup** screen, under the **ECT** tab, enter the number of devices in the **Quantity** field. (**Max** shows the maximum number of devices allowed on the network.)
4. Press to return to the **Network Setup** menu, then select - **Network Summary**.
5. Locate the units you added to the network list (press and to scroll through the list). If desired, enter a new name for each device in the **Name** field.

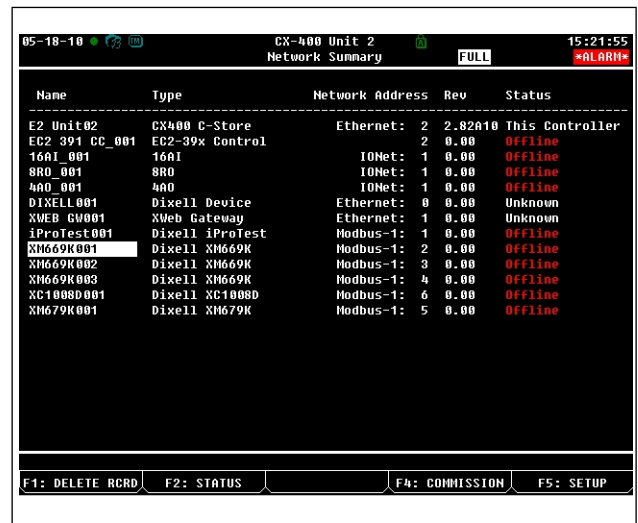

Figure 18-6 - Network Summary Screen

6. By default, each device in the network list has a board number of 0. To set the address and begin communication, choose the device and press **F4**. In the list of MODBUS devices, choose the address number corresponding to the XR75CX address set up through the front display, and press **Enter** to select it. A window will open where you can specify the address of the controller. If a network ID has already been selected, its name will be shown next to the network ID in this list. If the network ID you are trying to assign has already been used, you must set the address on this device to a different number that is not being used.

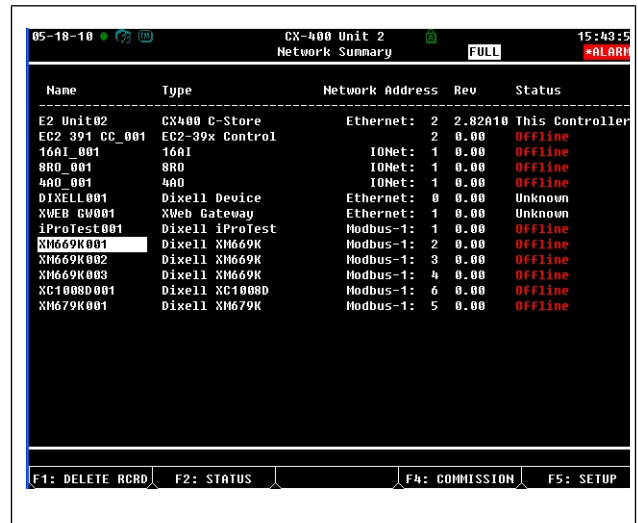

Figure 18-8 - Network Summary Screen

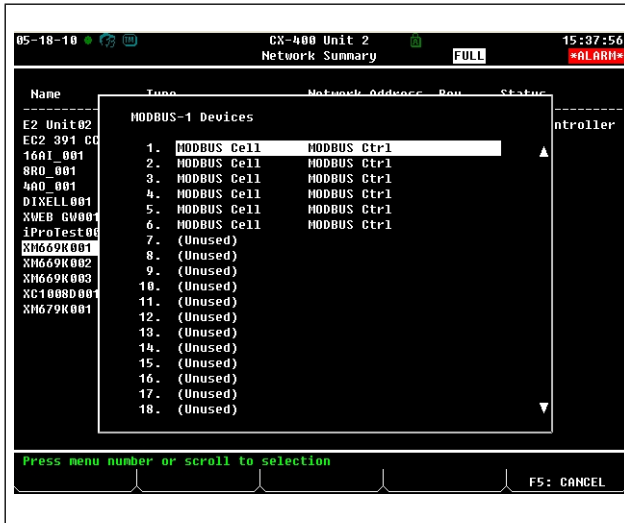

Figure 18-7 - List of MODBUS Devices

7. Repeat **Steps 5 and 6** until each device has a name and address.
8. When finished, press **ESC** to return to the **Network Setup** menu, then press **F1** - **Network Summary** (Figure 18-6). Locate the devices you set up, and look at each device's status in the **Status** field. You will see one of the following messages:
- **Online** - The device is communicating normally.
 - **Offline** - The device is not communicating, has not been commissioned, is not functional, or is not powered up. Verify the device is powered up, wired correctly, and has the proper network address, baud rate, and parity.
 - **Unknown** - The device is not communicating or has not been commissioned. Verify the device is powered up, wired correctly, and has the proper network address, baud rate, and parity.
 - **No Port** - No port is set up in the E2 Serial Configuration Manager to be a MODBUS port.
 - **Wrong FW Rev** - This message is likely caused by the device having a firmware version older than the minimum revision required by E2 for communication. Replace the device with a new one or a device that has the latest version of firmware on it.

18.4 Wiring Types

Copeland specifies Belden #8761 shielded twisted pair cables for use as MODBUS wiring (or Belden #82761 and Belden #88761 for plenum installations).

For MODBUS network wiring of XR75CX controllers to E2, Belden #8641 (P/N 135-8641) is the recommended wire type to use.

If the recommended cable is not available in your area, be sure the wiring meets or exceeds the following specs:

Shielded?	Yes
Conductor Type	Twisted Pair
Gauge	18 - 24 AWG
Capacitance between signal wires	31 pF/ft or less (9.45 m) or less
Capacitance between signal and shield	59 pF/ft or less (17.98 m) or less
Maximum Length	4000 ft/18 to 22 AWG (1219.2 m) 2500 ft/24 AWG (762 m)
Nominal Impedance	120W±50W

18.5 MODBUS Termination Blocks

Because the XR75CX device has no on-board means of termination, use the MODBUS termination block (P/N 535-2711) for termination that can be wired to the end of the cable segment using the three-pin connector. Wire the two signal wires to the outside terminals, and connect the shield to pin **18** of the device, keeping the exposed shield wire length as short as possible (3 inches ideal maximum length).

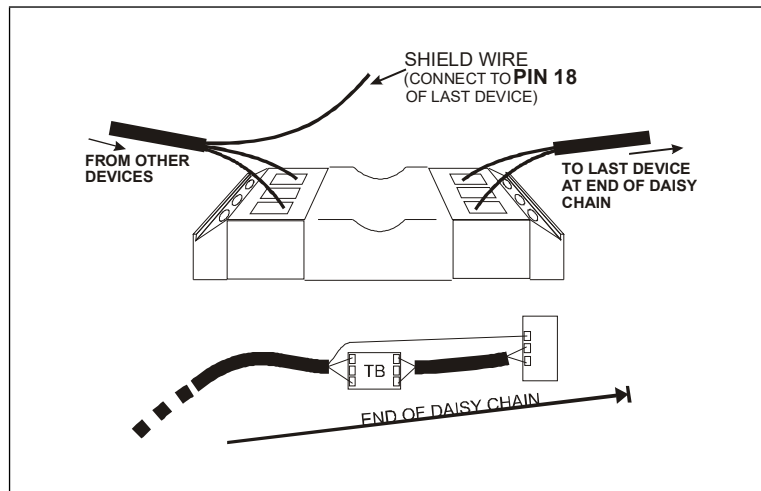

Figure 18-9 - MODBUS Termination Block (P/N 535-2711)

19 Default Setting Values

Table 19-1- XR75CX Default Setting Values (²Only for XR75CX with X-REP output)

Label	Name	Range	Value	Level
SEt	Setpoint	LS to US	[-5.0°C] [23°F]	---
HY	Differential	[0.1 to 25.5°C] [1 to 255°F]	[2.0°C] [2°F]	Pr1
LS	Minimum setpoint	[-50°C to SET] [-58°F to SET]	[-50.0°C] [-58°F]	Pr2
US	Maximum setpoint	[SET to 110°C] [SET to 230°F]	[110.0°C] [230°F]	Pr2
ot	Thermostat probe calibration	[-12 to 12°C] [-21 to 21°F]	[0.0°C] [0°F]	Pr1
P2P	Evaporator probe presence	n=not present; Y=pres.	Y	Pr1
oE	Evaporator probe calibration	[-12 to 12°C] [-21 to 21°F]	[0.0°C] [0°F]	Pr2
P3P	Third probe presence	n=not present; Y=pres.	n	Pr2
o3	Third probe calibration	[-12.0 to 12.0°C] [-21 to 21°F]	[0.0°C] [0°F]	Pr2
P4P	Fourth probe presence	n=not present; Y=pres.	n	Pr2
o4	Fourth probe calibration	[-12.0 to 12.0°C] [-21 to 21°F]	[0.0°C] [0°F]	Pr2
odS	Outputs delay at start up	0 to 255 min	0	Pr2
AC	Anti-short cycle delay	0 to 50 min	1	Pr1
rtr	P1-P2 percentage for regulation	0 to 100 (100=P1, 0=P2)	100	Pr2
CCt	Continuous cycle duration	0.0 to 24h 00min, res. 10min	0.0	Pr2
CCS	Setpoint for continuous cycle	[-50 to 110.0°C] [-58 to 230°F]	[-5°C] [23°F]	Pr2
Con	Compressor ON time with faulty probe	0 to 255 min	15	Pr2
CoF	Compressor OFF time with faulty probe	0 to 255 min	30	Pr2
CF	Temperature measurement unit	°C, °F	[°C] [°F]	Pr2
rES	Resolution	in=integer; dE= dec.point	dE	Pr1
Lod	Probe displayed	P1; P2	P1	Pr2
rEd2	X-REP display	P1; P2; P3; P4; SEt; dtr	P1	Pr2
dLY	Display temperature delay	0.0 to 20min 00s, res. 10s	0.0	Pr2
dtr	P1-P2 percentage for display	1 to 99	50	Pr2
tdF	Defrost type	EL=el. heater; in= hot gas	EL	Pr1

Table 19-1- XR75CX Default Setting Values ⁽²⁾Only for XR75CX with X-REP output)

Label	Name	Range	Value	Level
dFP	Probe selection for defrost termination	nP; P1; P2; P3; P4	P2	Pr2
dtE	Defrost termination temperature	[-50 to 50°C] [-50 to 122°F]	[8°C] [46°F]	Pr1
idF	Interval between defrost cycles	1 to 120 hours	6	Pr1
MdF	(Maximum) length for defrost	0 to 255 min	30	Pr1
dSd	Start defrost delay	0 to 99 min	0	Pr2
dFd	Displaying during defrost	rt, it, SEt, DEF	it	Pr2
dAd	MAX display delay after defrost	0 to 255 min	30	Pr2
Fdt	Draining time	0 to 120 min	0	Pr2
dPo	First defrost after start-up	n=after idF; Y=immed.	n	Pr2
dAF	Defrost delay after fast freezing	0 to 24h 00min, res. 10min	0.0	Pr2
FnC	Fan operating mode	C-n; o-n; C-Y; o-Y	o-n	Pr1
Fnd	Fan delay after defrost	0 to 255 min	10	Pr1
FCt	Differential of temperature to force fan activation	[0 to 50°C] [0 to 90°F]	[10°C] [10°F]	Pr2
FSt	Fan stop temperature	[-50 to 50°C] [-58 to 122°F]	[36°C] [23°F]	Pr1
Fon	Fan on time with compressor off	0 to 15 min	0	Pr2
FoF	Fan off time with compressor off	0 to 15 min	0	Pr2
FAP	Probe selection for fan management	nP; P1; P2; P3; P4	P2	Pr2
ACH	Kind of action for auxiliary relay	CL; Ht	CL	Pr2
SAA	Setpoint for auxiliary relay	[-50 to 110°C] [-58 to 230°F]	[0.0°C] [32°F]	Pr2
SHY	Differential for auxiliary relay	[0.1 to 25.5°C] [1 to 45°F]	[2.0°C] [2°F]	Pr2
ArP	Probe selection for auxiliary relay	nP; P1; P2; P3; P4	nP	Pr2
Sdd	Auxiliary relay operating during defrost	n; Y	n	Pr2
ALP	Alarm probe selection	nP; P1; P2; P3; P4	P1	Pr2
ALC	Temperat. alarms configuration	rE= related to set; Ab = absolute	Ab	Pr2
ALU	MAXIMUM temperature alarm	[SEt to 110.0°C] [SEt to 230°F]	[110°C] [230°F]	Pr1
ALL	Minimum temperature alarm	[-50°C to SEt] [-58°F to SEt]	[-50.0°C] [-58°F]	Pr1

Table 19-1- XR75CX Default Setting Values (²Only for XR75CX with X-REP output)

Label	Name	Range	Value	Level
AFH	Differential for temperat. alarm recovery	[0.1°C to 25.5°C] [1°F to 45°F]	[2.0°C] [2°F]	Pr2
ALd	Temperature alarm delay	0 to 255 min	15	Pr2
dAo	Delay of temperature alarm at start up	0 to 24h 00min, res. 10min	1.3	Pr2
AP2	Probe for temperat. alarm of condenser	nP; P1; P2; P3; P4	P4	Pr2
AL2	Condenser for low temperat. alarm	[-50 to 110°C] [-58 to 230°F]	[-40.0°C] [-40°F]	Pr2
AU2	Condenser for high temperat. alarm	[-50 to 110°C] [-58 to 230°F]	[110°C] [230°F]	Pr2
AH2	Differential for condenser temperature alarm recovery	[0.1°C to 25.5°C] [1°F to 45°F]	[5°C] [5°F]	Pr2
Ad2	Condenser temperature alarm delay	0 to 254 min, 255=nU	15	Pr2
dA2	Delay of cond. temper. alarm at start up	0.0 to 24h 00min, res. 10min	1.3	Pr2
bLL	Compr. off for condenser low temperature alarm	n; Y	n	Pr2
AC2	Compressor off because of condenser high temperature alarm	n; Y	n	Pr2
tbA	Alarm relay disabling	n; Y	Y	Pr2
oA2	Second relay configuration	ALr = alarm; dEF = do not select it; LiG =Light; AUS =AUX; onF=always on; FAn= do not select it; db = neutral zone; CP2 = second compressor; dF2 = do not select it; HES = night blind	LiG	Pr2
AoP	Alarm relay polarity (oA2=ALr)	oP; CL	CL	Pr2
i1P	Digital input polarity (18-20)	oP=opening; CL=closing	CL	Pr1
i1F	Digital input 1 configuration (18-20)	dor; dEF;	dor	Pr1
i2P	Digital input polarity (18-19)	oP=opening; CL=closing	CL	Pr2
i2F	Digital input configuration (18-19)	EAL; bAL; PAL; dor; dEF; ES; AUS; Htr; FAn; HdF; onF	EAL	Pr2
did	Digital input alarm delay (18-20)	0 to 255 min	15	Pr1

Table 19-1- XR75CX Default Setting Values (²Only for XR75CX with X-REP output)

Label	Name	Range	Value	Level
doA	Door open alarm delay	0 to 255 min	15	Pr1
NPS	Number of activation of pressure switch	0 to 15	15	Pr2
odC	Compress and fan status when door open	no; FAn; CP; F_C	F-C	Pr2
rrd	Regulation restart with door open alarm	n; Y	Y	Pr2
HES	Differential for Energy Saving	[-30°C to 30°C] [-54°F to 54°F]	0	Pr2
Adr	Serial address	1 to 247	1	Pr2
PbC	Kind of probe (set to CtC for standard CPC temp sensors - factory default)	ntC; CtC	ntC	Pr2
onF	on/off key enabling	nU, oFF; ES	nU	Pr2
dP1	Room probe display	--	-	Pr1
dP2	Evaporator probe display	--	-	Pr1
dP3	Third probe display	--	-	Pr1
dP4	Fourth probe display	--	-	Pr1
rSE	Real set	actual set	-	Pr2
rEL	Software release	--	5.6	Pr2
Ptb	Map code	--	-	Pr2

Appendix A - Alternate MODBUS COM Wiring Method for E2, XR, XM, and XEV Devices

Overview

To simplify MODBUS communication wiring with E2, (both Standard and Enhanced versions) XR, XM, and XEV series devices, the alternate method outlined below may be used.

Wire Type

Use Belden 8761 or equivalent cable.

Shield

DO NOT connect the shield to the device. Keep the shield continuous throughout a network segment. The shield must be twisted together and insulated with electrical tape or heatshrink at each device within a network segment. Securely connect the shield to an earth grounded chassis at each end of a network segment.

Termination

Each network segment must be biased and terminated at the E2 controller's end (all three jumpers in the MOD position for E2 Enhanced, or all three jumpers in the UP position for E2 Standard) and terminated with a 150 ohm resistor at the other end of the network segment (150 ohms between the two communication wires).

Recommended

For reliable communication on some installations, it may be necessary to connect a 100 ohm resistor between the XR, XM, or XEV device's previously identified ground terminal and earth ground.

Some E2 MODBUS COM Ports Can Support Two Network Segments

For E2 Enhanced 4.x Controller Hardware

COM2 supports two network segments: one on connector RS485-COM2A, and the second on connector RS485-COM2B.

COM4 supports two network segments: one on connector RS485-COM4A, and the second on connector RS485-COM4B.

COM6 only supports one network segment on connector RS485-COM6.

For E2 Standard 3.x Controller Hardware

COM2 supports two network segments: one on connector RS485-1A, and the second on connector RS485-1B.

For information on the maximum recommended number of XR, XM, and XEV devices for each network segment (load and bandwidth calculations), contact Copeland Technical Support at 770-425-2724.

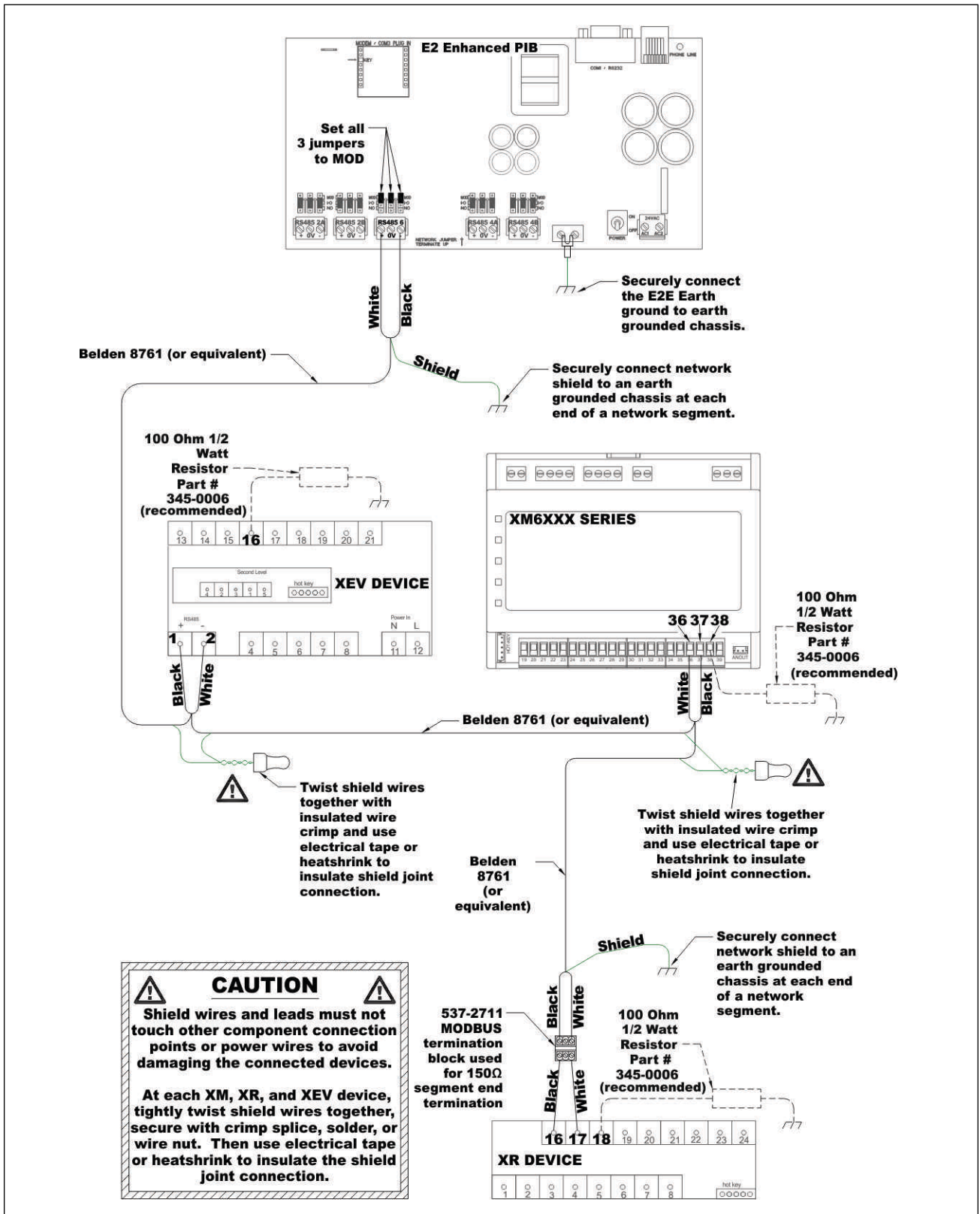

Figure A-1 - MODBUS Com Wiring Diagram

Visit our website at copeland.com/en-us/products/controls-monitoring-systems for the latest technical documentation and updates.
For Technical Support call **833-409-7505** or email **ColdChain.TechnicalServices@Copeland.com**

The contents of this publication are presented for informational purposes only and they are not to be construed as warranties or guarantees, express or implied, regarding the products or services described herein or their use or applicability. Copeland reserves the right to modify the designs or specifications of such products at any time without notice. Responsibility for proper selection, use and maintenance of any product remains solely with the purchaser and end-user.
©2024 Copeland is a trademark of Copeland LP.