

# Copeland Scroll™ Compressor

Fusion for refrigeration applications



User manual

**COPELAND™**

  
**EMERSON™**

## About Emerson Climate Technologies

Emerson Climate Technologies, a business segment of Emerson™, is the world's leading provider of heating, air-conditioning and refrigeration solutions for residential, industrial, and commercial applications. It combines best-in-class technology with proven engineering, design, distribution, educational and monitoring services to provide customized, integrated climate-control solutions for customers worldwide. Emerson Climate Technologies' innovative solutions, which include industry-leading brand Copeland Scroll™, improve human comfort, safeguard food and protect the environment. For more information, visit EmersonClimateAsia.com.

## Leading Innovation in Scroll Semi-Hermetic Technology

Emerson realized an increasing need for a versatile, reliable, quiet, lightweight, serviceable compressor for the Cold Room market and set out to develop a solution for this need. In the development process, the company brought together 70 years of semi-hermetic compressor expertise and 25 years of leadership in scroll technology. What came out of this endeavor is the newly-designed Copeland Scroll Fusion compressor which combines Emerson's revolutionary scroll technology along with the serviceability of a traditional semi-hermetic compressor.

## Our Vision:

Emerson Climate Technologies, with our partners, will provide global solutions to improve human comfort, safeguard food and protect the environment.



## Table of Contents



Safety Information	04
Features and Benefits	05
Nomenclature	05
Operating Envelopes	06
Technical Data	07
Dimensional Drawings	10
Wiring Diagram	14
Contact Lists	24

## Safety Information

Copeland™ brand products semi-hermetic compressors are manufactured according to international safety standards. Particular emphasis has been placed on the user's safety. This user manual should be retained throughout the lifetime of the compressor.

Safety instructions must be followed by all users before compressor operation. Only qualified and authorized personnel are permitted to do installation, commissioning and repairing of this compressor. Electrical connections must be made by qualified electrical personnel.

### ICON DEFINITION

 <p><b>CAUTION</b> This icon indicates instructions to avoid property damage and possible personal injury.</p>	 <p><b>WARNING</b> This icon indicates instructions to avoid personal injury and material damage.</p>	 <p><b>ELECTRICAL SHOCK</b> This icon indicates operations with a danger of electric shock.</p>
---	--	---

### Caution

- Make sure that the compressor is upright and there are no collisions or tilting during transit.
- Use only refrigerants and oils approved by Emerson.
- Make sure that the supply power, voltage, frequency and phase are exactly as per the specifications on the compressor nameplate.
- The dry air inside the compressor should be evacuated before installation. The compressor comes charged with dry air at a pressure of 2.0 bar.

### Do Not:

- Use the compressor to de-pressurize (to evacuate) a refrigeration system.
- Start the compressor when it is under vacuum.
- Conduct a test without connecting the compressor to a system.
- Start the compressor without a refrigerant charge.
- Operate a compressor beyond its approved application envelope.
- Touch the compressor or pipes when the compressor is running. High/low temperature may cause burns/frostbite.
- Release refrigerant into the environment without using appropriate refrigerant recovery unit and methods when removing refrigerant from the system.

### Warning

- When operating the compressor or checking a refrigeration system leakage, do not exceed operating pressures out of the application envelope.

- Do not run the compressor with air. When operating with air, the diesel effect may occur – i.e. the air sucked in may mix with oil and gas. Such a mixture could explode due to high temperature in the scroll discharge port and thereby destroy the compressor and cause injury or death.
- Open the discharge and suction shut-off valve before starting the compressor. It is of vital importance that the discharge shut-off valve is fully opened before the compressor is started. If the discharge valve is closed or partly-closed, an unacceptable pressure accompanied by a proportionately high temperature will develop.
- All local safety regulations must be observed.

### Electrical Shock

- Turn off electrical supply and power before servicing.
- Use this equipment only in a grounded system.
- Refer to the applicable system-wiring diagram as shown in this manual.



### Use Personal Safety Equipment

- The new compressor contains oil and dry air under a pressure of 2.0 bar. While releasing pressure before installation, the oil drain plug may pop out under pressure and oil could spurt out.
- Safety gloves, protective clothing, safety boots and protective eyewear should be worn where necessary.

## Product Description

Copeland Scroll™ Fusion was crafted specifically to adhere to the refrigeration industry's need for field serviceable solutions. In addition, it is specially designed for medium and low temperature refrigeration with the ability to handle various refrigerants.

## Features and Benefits

- Emerson's Copeland Scroll technology
- Serviceability in the field
- CoreSense™ Diagnostics
- Integrated vapor injection technology
- Wide range envelope and efficient operation
- Ability to handle various refrigerants



## Nomenclature

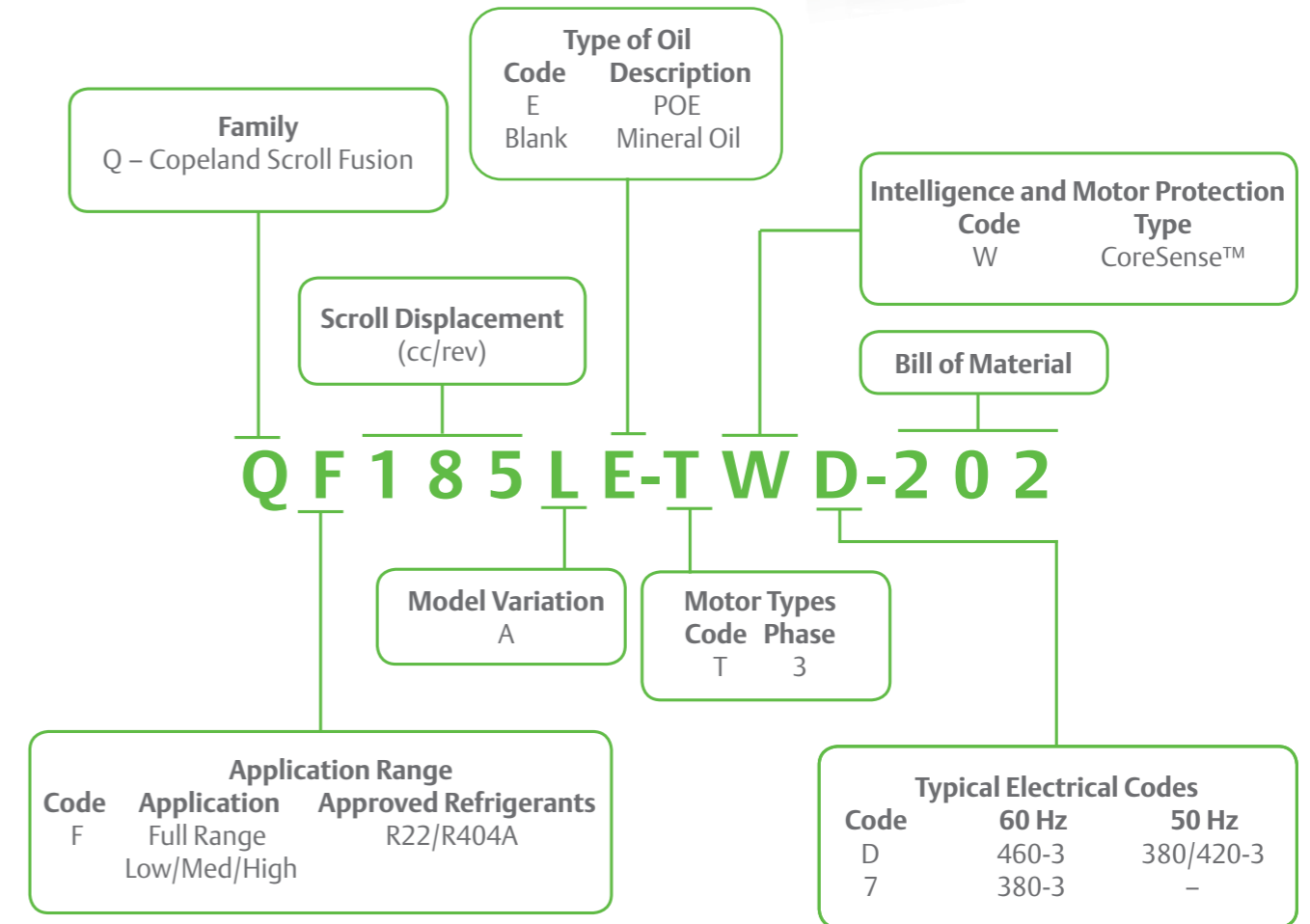

Note: QF205 has low temperature model only.

# Operating Envelopes

R22/R404A

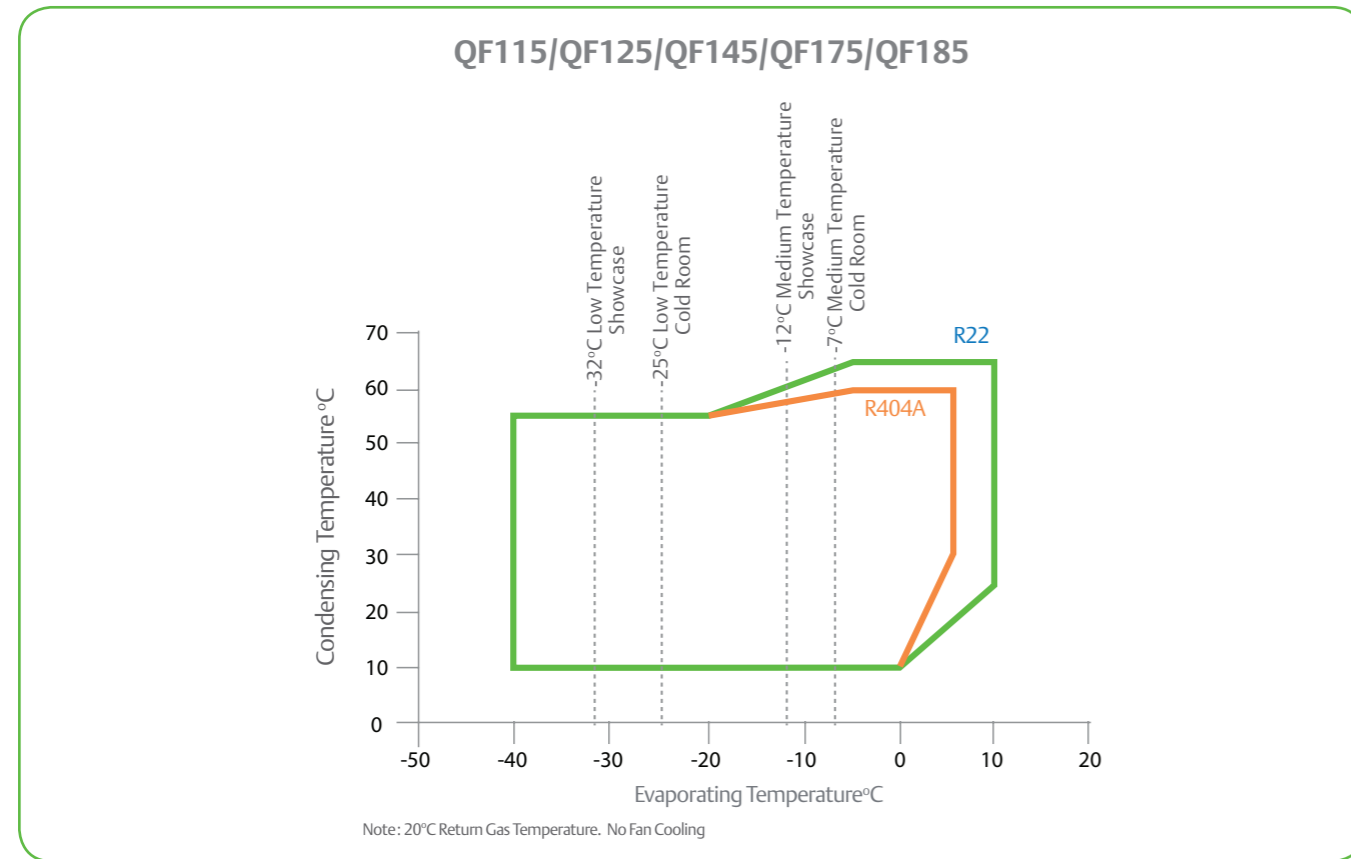

R22/R404A

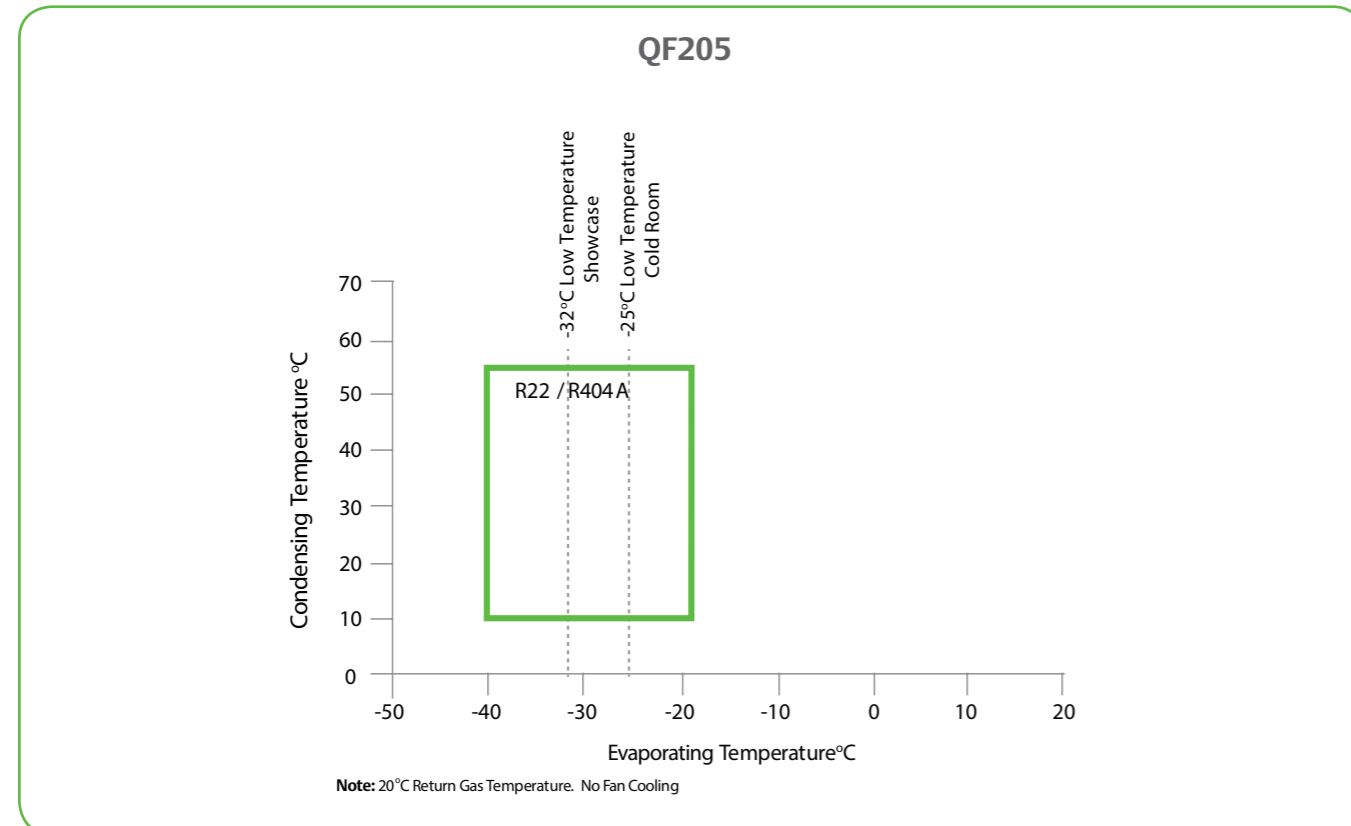

# Nameplate Information

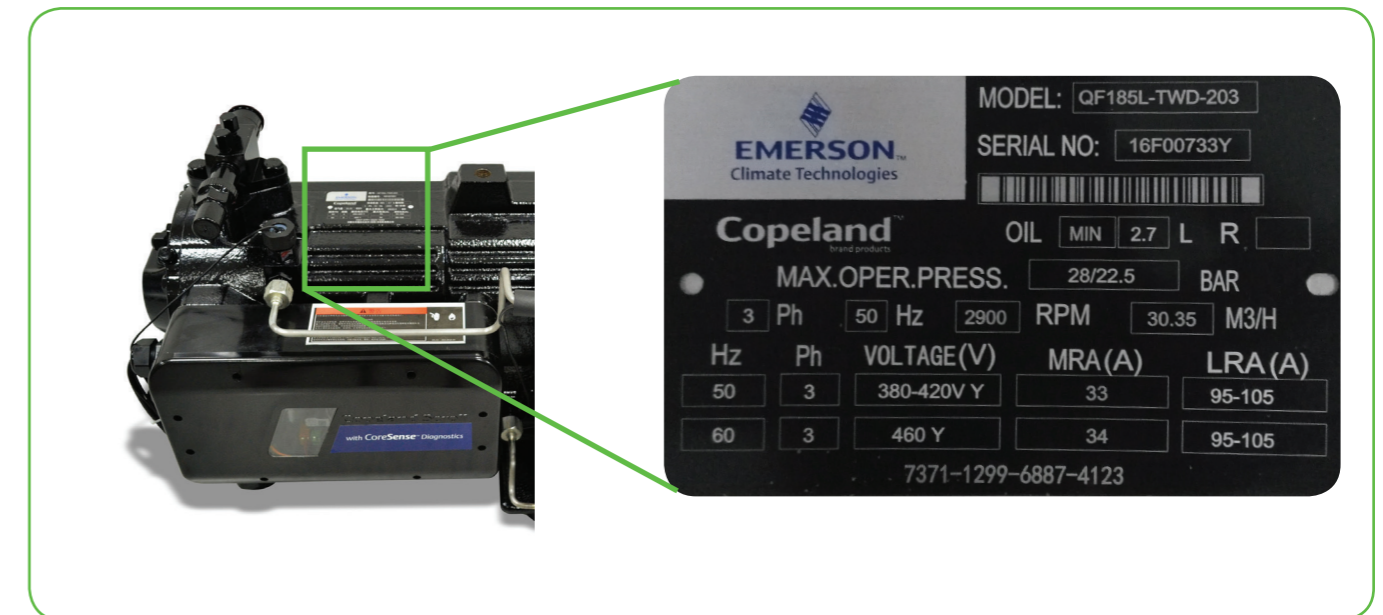

Figure 1. Nameplate and nameplate location

# Technical Data

Model		R22	QF115L	QF125L	QF145L	QF175L	QF185L	QF205L
		R404A	QF115LE	QF125LE	QF145LE	QF175LE	QF185LE	QF205LE
Displacement	TWD 50 Hz	m <sup>3</sup> /h	19.3	21.1	23.5	26.4	30.4	36.9
MOC	TWD 50 Hz	A	24	25	27	32	33	25
LRA			80	80	80	105	105	105
Motor Speed	TWD 50 Hz	rpm	2900					
Displacement	TW7 60 Hz	m <sup>3</sup> /h	23.2	25.4	28.3	31.9	36.6	43.1
MOC	TW7 60 Hz	A	30	34	32	30	34	32
LRA			94	94	94	94	94	94
Motor Speed	TW7 60 Hz	rpm	3500					
Crankcase Heater	Power	W	60					
	Voltage	V	220					
Oil Charge	Initial	L	2.66					
	Recharge		2.54					
Service Valves	Suction	in	1-1/8					
	Discharge		1					
Dimensions	Length	mm	675					
	Width		355					
	Height		389					
Base Mounting	Length	mm	350					
	Width		200					
	Bolt		M10					
Weight	Net	kg	130					
	Gross		140					

- Notes: 1. MOC: Maximum Operating Current  
 2. LRA: Locked Rotor Current  
 3. QF205LE has low temperature model only

## Maximum Operating Pressures



A high-pressure control with a maximum cut-out setting of 28 bar(g) is required. The high-pressure cut-out should have a manual reset feature for the highest level of system protection.

The low-pressure cut-out should be set as high as possible in all applications. For medium temperature applications, the normal minimum is 2.5 bar(g) which corresponds to -10°C for R22 and -16°C for R404A.

For low temperature applications the minimum cut-out setting should not be lower than 0.3 bar(g) for a compressor using R404A, and should not be lower than 0.1 bar(g) for a compressor using R22. The cut-out point of the LP switch must be calibrated using an accurate suction pressure gauge rather than the scale on the switch which is provided for rough setting only.



The Copeland Scroll™ Fusion compressor should NEVER be allowed to run in a vacuum. The low-pressure cut-out should have a manual reset feature for the highest level of system protection.



The maximum pressure for leak testing should be no higher than 22.5 bar(g).

## Approved Refrigerants and Oil

Refrigerants R404A and R22 are approved for use with Copeland Scroll Fusion. Application with other refrigerants may be possible in special cases. Please contact an Emerson Climate Technologies Application Engineer.

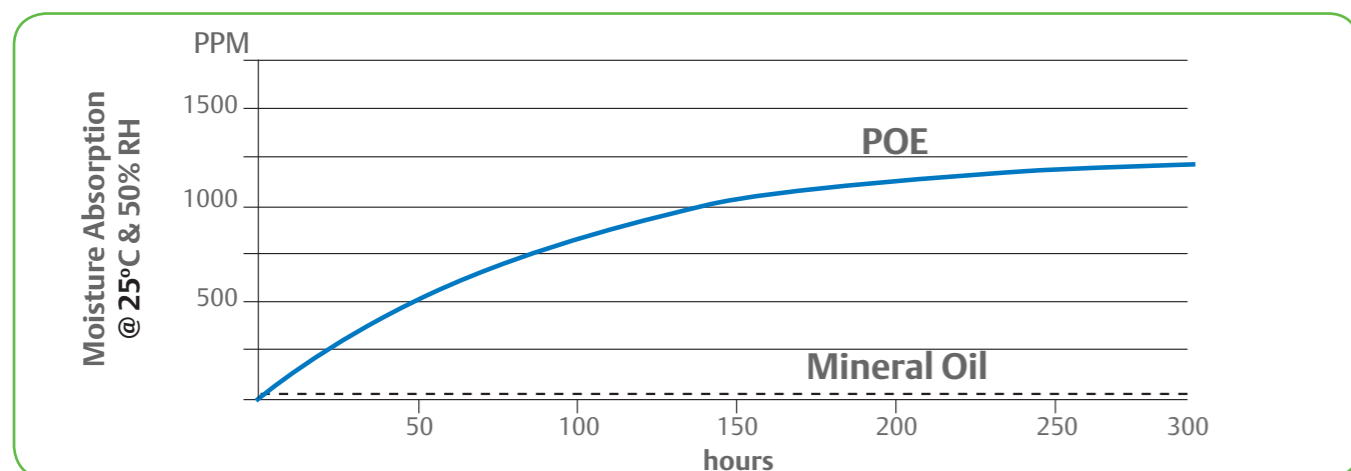

Figure 2. Absorption of moisture in ester oil in comparison to mineral oil in ppm by weight at 25°C and 50% relative humidity.

The compressor is supplied with an initial oil charge. Mineral oils are approved for R22 application, and Karamay 32BYMO is filled ex-factory. The standard oil charge for use with R404A is a polyester (POE) lubricant Emkarate RL 32-3MAF. In the field, the oil level could be topped up with Mobile EAL Arctic 22 CC if 3MAF is not available.



Do not mix ester oils with mineral oil and/or alkyl benzene when using chlorine-free (HFC) refrigerants. See nameplate for original oil charge in litres. A field recharge is from 50-100 ml less than the original charge.



Oil must be drained from both the high and low sides of the compressor whenever oil is changed.

One disadvantage of POE is that it is far more hygroscopic than mineral oil (see Figure 2). Brief exposure to ambient air causes POE to absorb sufficient moisture to make it unfit for use in a refrigeration system. Since POE holds moisture more readily than mineral oil, it is more difficult to remove it through the use of a vacuum. Compressors supplied by Emerson Climate Technologies contain oil with low moisture content, and this may rise during the system assembling process. POE oil should not be exposed to the atmosphere for longer than 15 minutes. A filter drier is installed to help maintain moisture level in the oil less than 50 ppm. If oil is charged into a system, it is recommended to use POE with a moisture content no higher than 50 ppm.

## Installation

### Compressor Handling

#### Delivery

Please check carefully for unforeseen damage. Any shortage or damage should be reported to the delivering carrier. Heavy equipment should be left on its shipping base until it is moved to the final location.

The packing list included with each shipment should be carefully checked to determine if all parts and equipment have been received. Deficiencies should be immediately reported in writing to your local Emerson Sales Office.

#### Standard delivery

- Suction and discharge shut-off valves
- Oil charge, oil sight glass
- Oil level sensor
- Oil differential pressure switch
- Oil temperature sensor
- Plate heat exchanger
- Electronic expansion valve
- Crankcase heater
- CoreSense™ Diagnostics
- Holding charge of up to 2.0 bar (dry air)
- For other accessories, please check the packing list

#### Packaging

All compressors are individually packed. Accessories may be mounted or delivered loose. Please pay attention to stacking layers. Stacking in transit should not be more than two layers and stacking in-store should not be more than three layers. The packaging must be kept dry and without damage at all times.

#### Transport

Compressors should be moved only with mechanical handling equipment appropriate for the weight involved. For safety reasons, one lifting eye should be fitted before moving a compressor (M16x2.0). Please refer to the illustrations on Figure 3 to see how to lift the compressor safely.



The compressors must not be lifted by the service valves or other accessories. Otherwise damage or refrigerant leaks may occur.

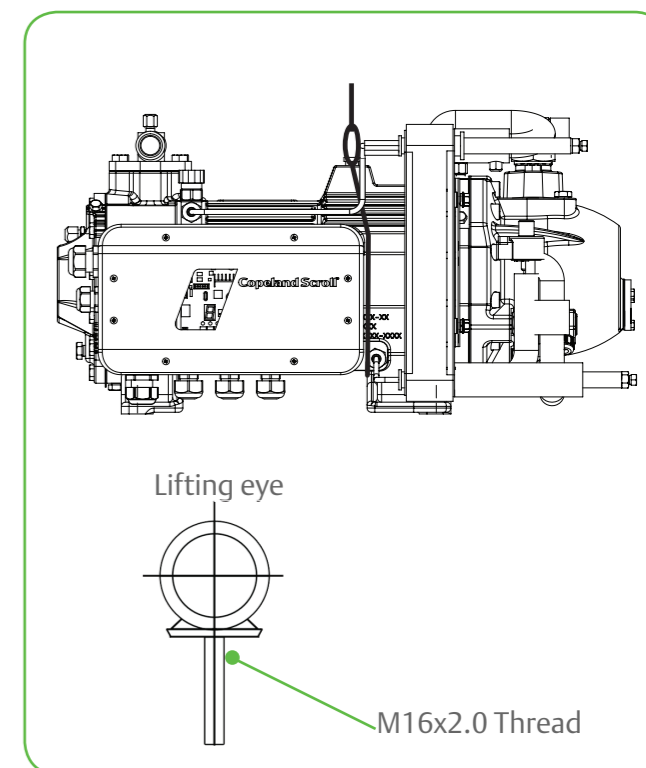

Figure 3. Compressor lifting method

### Mounting Parts



To minimize vibration and start/stop impulses, flexible mountings should be used. Because Copeland Scroll™ Fusion has scroll hermetic compressor level of vibration, grommets are delivered. A compressor may be rigidly mounted (i.e. without grommet) - in which case, more shock and vibration will be transmitted to the frame.

To ensure proper lubrication of moving parts, the compressor should be installed with four mountings in the same plane.

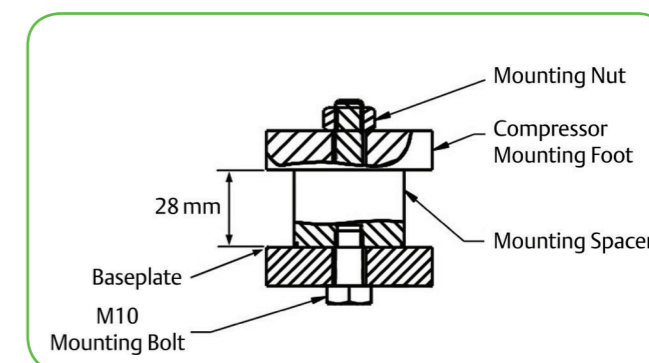

Figure 4. Mounting Kit

Mounting Kit Part Code: 027-0443-00

## Piping Connection and Compressor Installation

### Brazing

- It is important to flow nitrogen through the system while brazing all joints during the system assembly process. Nitrogen displaces the air and prevents the formation of copper oxides in the system.
- Recommended brazing materials: any material is recommended, preferably with a minimum of 45% silver.
- Be sure valves I.D. and connecting tube O.D. are clean prior to assembly. If oil film is present, wipe with denatured alcohol, Dichlorotrifluoroethane or other suitable solvent.
- Using a double-tipped torch apply heat in Area 1. As tube approaches brazing temperature, move torch flame to Area 2.
- Heat Area 2 until braze temperature is attained, moving torch up and down and rotating around tube as necessary to heat tube evenly. Add braze material to the joint while moving torch around joint to flow braze material around circumference.

- After brazing material flows around joint, move torch to heat Area 3.
- This will draw the braze material down into the joint. The time spent heating Area 3 should be minimal.
- As with any brazed joint, overheating may be detrimental to the final results.
- When welding the discharge line connection pipe to the discharge service valve, the O-ring must be replaced with a new one. Replacement O-ring can be found on the accessory bag.
- If the suction and discharge shut-off valve bolts or rotary valve joint are released while brazing the shut-off valves, replace the shut-off valve spacer or O-ring. The non-metal valve spacer and O-ring must be oiled prior to assembly.

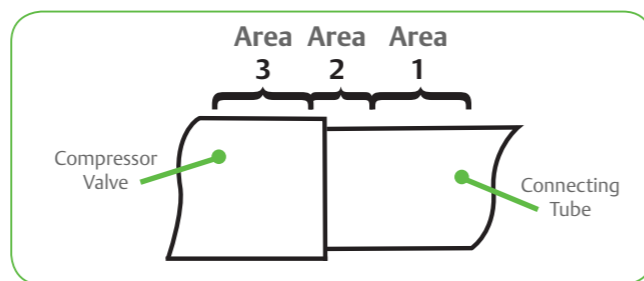

Figure 5. Brazing

### Dimensional Drawings

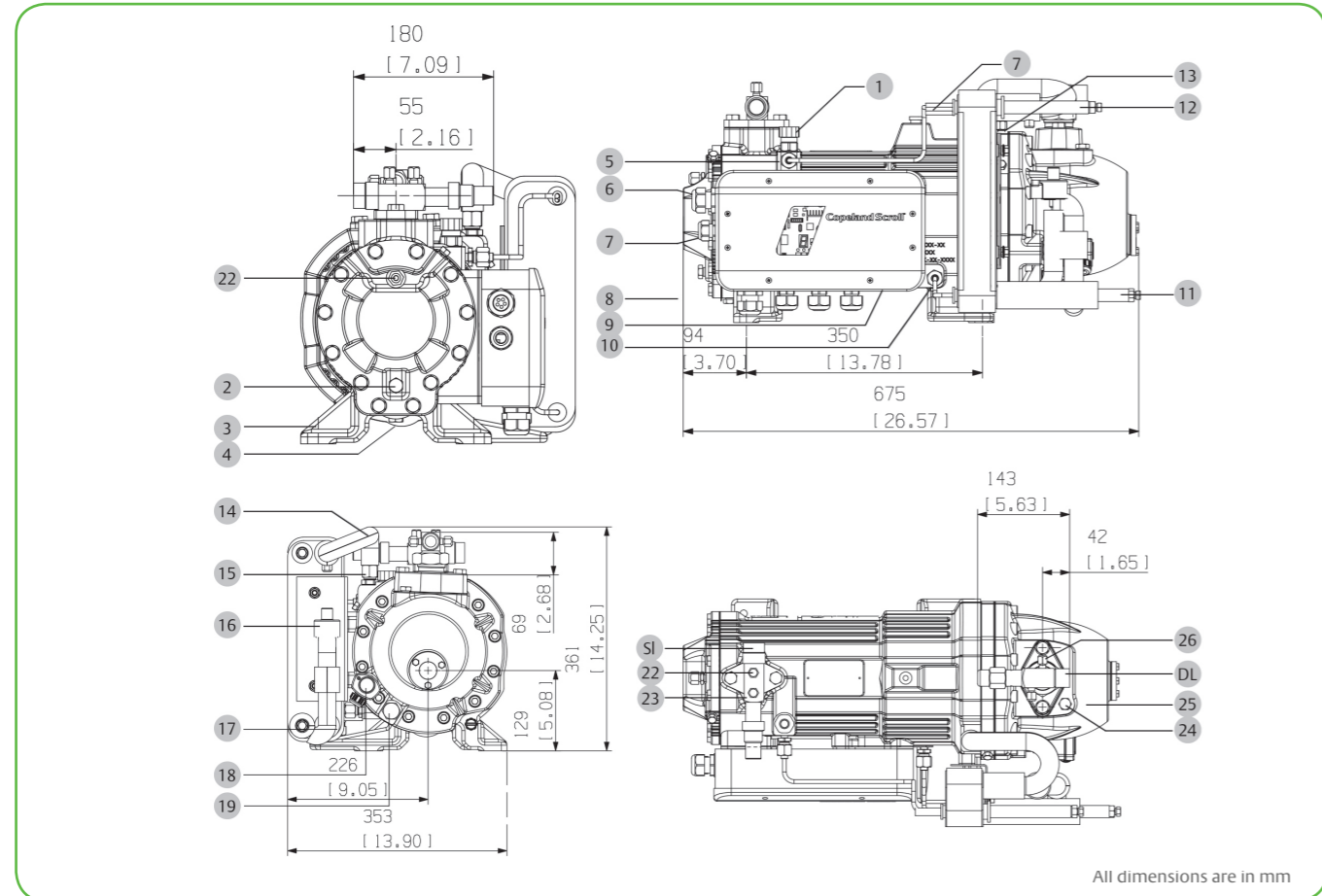

Figure 6. Compressor connection and ports. For identification refer to the Table on the next page.

No.	Connection/Port	Size	No.	Connection/Port	Size
1	DPS (differential pressure switch)	3/4"-16UNF	2	Plug low-pressure connection	1/4"-18NPTF
3	Bolt-mounting	M10	4	Plug oil drain	1/4"-18NPTF
5	Nut-oil out fitting	M16	6	Connector DLT/VIT/VOT/optical OLS/DPS	
7	Connector EXV/oil temperature sensor		8	Screw grounding	M5
9	Connector optional		10	Nut- oil in fitting	M16
11	Liquid out	3/4"	12	Liquid in	3/4"
13	DLT sensor		14	Vapor out temperature sensor	
15	Nut- EVI fitting	M20	16	EXV Coil	
17	Vapor in temperature sensor		18	Optical oil level sensor	7/8"-14UNF
19	Built-in oil screen	M20	20	Oil level sight glass	
21	Crankcase heater		22	Low pressure port	
23	Suction valve	28.7 ID	24	Plug high-pressure connection	1/4"-18NPTF
25	Discharge valve	25.7 ID	26	High pressure port	

Notes: SL: Suction Line  
DL: Discharge Line

#### To disconnect:

- Reclaim refrigerant from both the high and low side of the system. Cut tubing near compressor.

#### To reconnect:

- Recommended brazing material is one with minimum 45% silver or silver braze material with flux. Insert tubing stubs into fitting and connect to the system with tubing connectors. Follow instructions on Brazing.

### Piping Connections

Copeland Scroll™ Fusion has very low vibration characteristics, so discharge and suction vibration eliminators should not be necessary in the majority of installations. The suction, discharge and liquid pipes should all have sections running close to the compressor body in parallel with the shaft to absorb any startup or shutdown torsion. Vibration is much lower than those found in equivalent piston compressors, and discharge pulsations are negligible due to the muffling effect of the discharge cover.

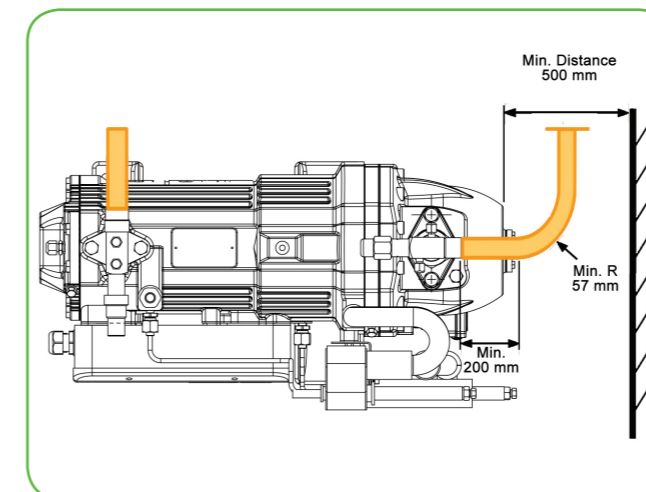

Figure 7. Piping guideline

Recommended minimum straight length from discharge valve to first bending point is 200 mm, minimum bending radius is 60 mm.

For ease of service, a minimum space of 500 mm between top cap surface to casing wall is recommended. Refer to Figure 7.

### Vapor Injection and Liquid Line Temperatures

Copeland Scroll Fusion compressor package applies vapor injection technology to improve LT operational efficiency and provides a reliable LT envelope. Vapor injection subcools the main liquid line and compressor oil using the integrated plate heat exchanger economizer. The subcooling of liquid line calls for these recommendations:

1. Liquid line pipe connecting the economizer to the evaporator expansion valve has to be well insulated separately. See Liquid Line Insulation for insulation thickness.
2. The lower liquid line temperature can increase the evaporator expansion valve capacities. Please follow valve manufacturers recommended liquid temperature correction factors for proper selection of evaporator expansion valve. Refer to catalogue or contact your local Emerson sales office for liquid line temperatures.

## Liquid Solenoid Valve

A liquid line solenoid valve is effective in keeping liquid out of the low side when the system cycles on the thermostat. The solenoid should be installed close to the expansion valve to keep the main volume of the liquid line on the high side of the system during off periods. All solenoid valves leak slightly and may not be 100% effective in keeping liquid in the high side during extended shutdown periods which can occur in cold rooms used for storing seasonal products. In most cases, opening and closing the solenoid valve when the compressor starts and stops provides adequate protection from liquid migration to the compressor crankcase.

## Liquid Line Insulation

Copeland Scroll™ Fusion compressors have many characteristics found on two-stage piston compressors, among them, a cold liquid line after the heat exchanger. The cold liquid is very important for improving the system capacity and efficiency, and any increase in liquid line temperature after the heat exchanger is a system loss. The liquid line should therefore be insulated with tightly-fitted closed cell foam. The wall thickness of the insulation should be at least 10 mm for medium temperature applications and >15 mm for low temperature applications. In some low temperature applications, an uninsulated liquid line could even cause ice formation, and in humid environments condensation will occur. The line connecting the receiver to the inlet of the heat exchanger does not require insulation.

## Pumpdown Cycle

Pumpdown cycles are widely applied in systems with reciprocating compressors. Copeland Scroll Fusion compressors have inherently superior liquid handling capability, so a pumpdown at each thermostat cycle is not recommended. A pumpdown cycle before defrost will be helpful in reducing the defrost time. Copeland Scroll Fusion compressors are fitted with a spring loaded low-leak check valve under the discharge service valve, so an external check valve should not be necessary. When pumpdown finishes, the compressor will stop and contain a very large volume of high pressure gas in the top cap area. This refrigerant will quickly leak back to suction and will cause a significant pressure rise that could reset the low pressure switch. The control circuit should not allow the compressor to restart; restart should only occur when the thermostat closes.

## High Pressure and Low Pressure Cut-out Settings

A high-pressure control with a maximum cut-out setting of 28 bar(g) is required. The high-pressure cut-out should have a manual reset feature for the highest level of system protection.

The low-pressure cut-out should be set as high as possible in all applications. For medium temperature applications the normal minimum is 2.5 bar(g) which corresponds to -10°C with R22 and -16°C with R404A. For low temperature applications the minimum cut-out setting should not be lower than 0.3 bar(g) for a compressor using R404A, and should not be lower than 0.1 bar(g) for a compressor using R22. The cut-out point of the LP switch must be set using an accurate suction pressure gauge rather than the scale on the switch which is provided for rough setting only.



Copeland Scroll Fusion compressor should NEVER be allowed to run in a vacuum.

The low-pressure cut-out should have a manual reset feature for the highest level of system protection.

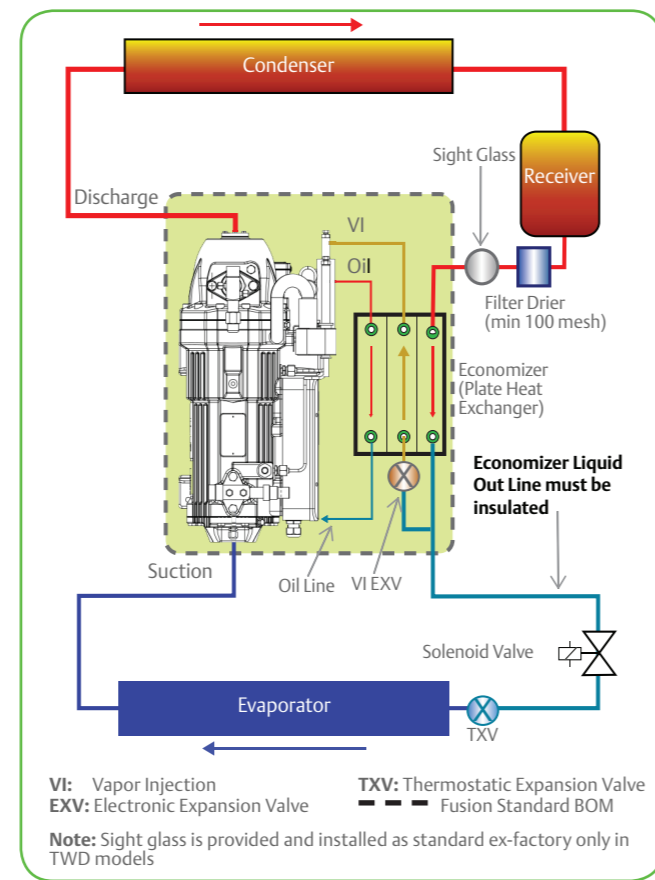

Figure 8. Schematic Diagram

## Electrical Installation

The compressor is supplied with a wiring diagram inside the terminal box cover as shown in Figure 10. Fuses and circuit breakers must be installed in accordance with local electrical regulations. The terminal box has an IP54 rating.



### Electrical Shock

Conductor Cables! Electrical Shock! Shut Off Power before High potential testing



### Warning

The compressor and accessories are tested for leakage to ground before shipping. Disconnect the control board PWR and DEMAND connections to avoid any risk of damage during high potential testing.

## Three-phase Motors

All compressors can be started direct on line only.

## Control Board Connection

The control board, which is mounted in the terminal box, monitors the compressor sensors, protects the compressor, drives the electronic expansion valve and displays useful information in a seven segment display. Three red LEDs indicate the status of the CCC (compressor contractor coil), Alarm and a relay which is connected to the black terminal block. The board is powered via a transformer with a nominal output of 16 VAC. When correctly wired and powered up the board goes through a self checking routine and displays a flashing 0. If the display is blank, check the power supply on the PWR, the transparent fuse, the transformer input and output, and the white fuse. The transparent fuse (250 V 2A) protects the transformer and other on-board electronic components. The white fuse (250 V 1A) protects the system control circuit and the on-board relays from external short circuits.

## Wiring Diagram and Wiring Instruction

The position of the 4-Bit Dip Switch in the terminal box and the recommended wiring diagrams are shown in Figures 9 and 10.

## Fusion Control Box Wiring Standard

According to Figure 11, there are 4 joints at the bottom of the control box. Each joint has dedicated wires to be assembled. Table 1 explains the function, requirement and connection method of each joint and wires inside. Wire C, D and G have been pre-wired in factory. C (Black) and D (Orange) are for compressor start/stop feedback input, connecting to “Demand” (Blue) connectors. G (Red) is wire of power input for Alarm Devices, connecting to “Alarm”

(Orange) connector. The wire size for these three pre-wirings is 18AWG.

Figure 12, on the other hand, shows the recommended wiring sequence for the control box.

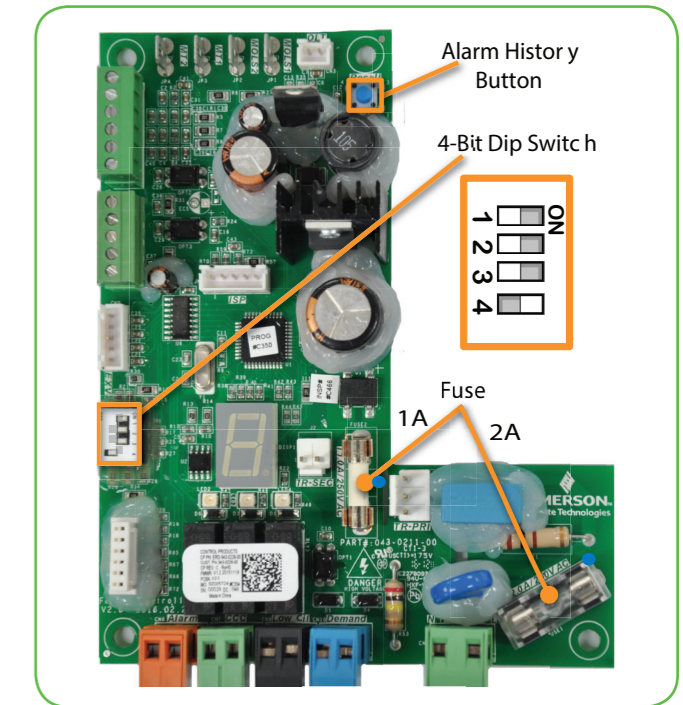

Figure 9. CoreSense™ Diagnostics Board

## CoreSense™ Diagnostics

The CoreSense Diagnostics module in the terminal box monitors several sensors and protects the compressor from the following malfunctions:

- Reverse rotation by oil differential pressure switch
- Compressor not pumping by oil differential pressure switch
- High discharge temperature by discharge port temperature sensor
- High oil temperature by oil temperature sensor
- Low oil level by optical oil level sensor
- Motor overheat by embedded four thermistors
- High pressure – cut-out to be connected by system manufacturer or installer
- Low pressure – cut-out to be connected by system manufacturer or installer

CoreSense Diagnostics module is functioned to record latest 10 alarm histories. By pushing one button on the board, the user can check the alarm codes from latest to distant in sequence on LED display. The display starts from “H” and ends with “h”. When alarm code is blank, the display will show “0” instead.



### Warning

High Pressure and Low Pressure switches must be fitted by the system manufacturer and connected to the pressure ports shown in the compressor outline drawing on Figure 6. HP and LP cut-out switches must be electrically connected as shown in the wiring diagram on Figure 10.

# Wiring Diagram

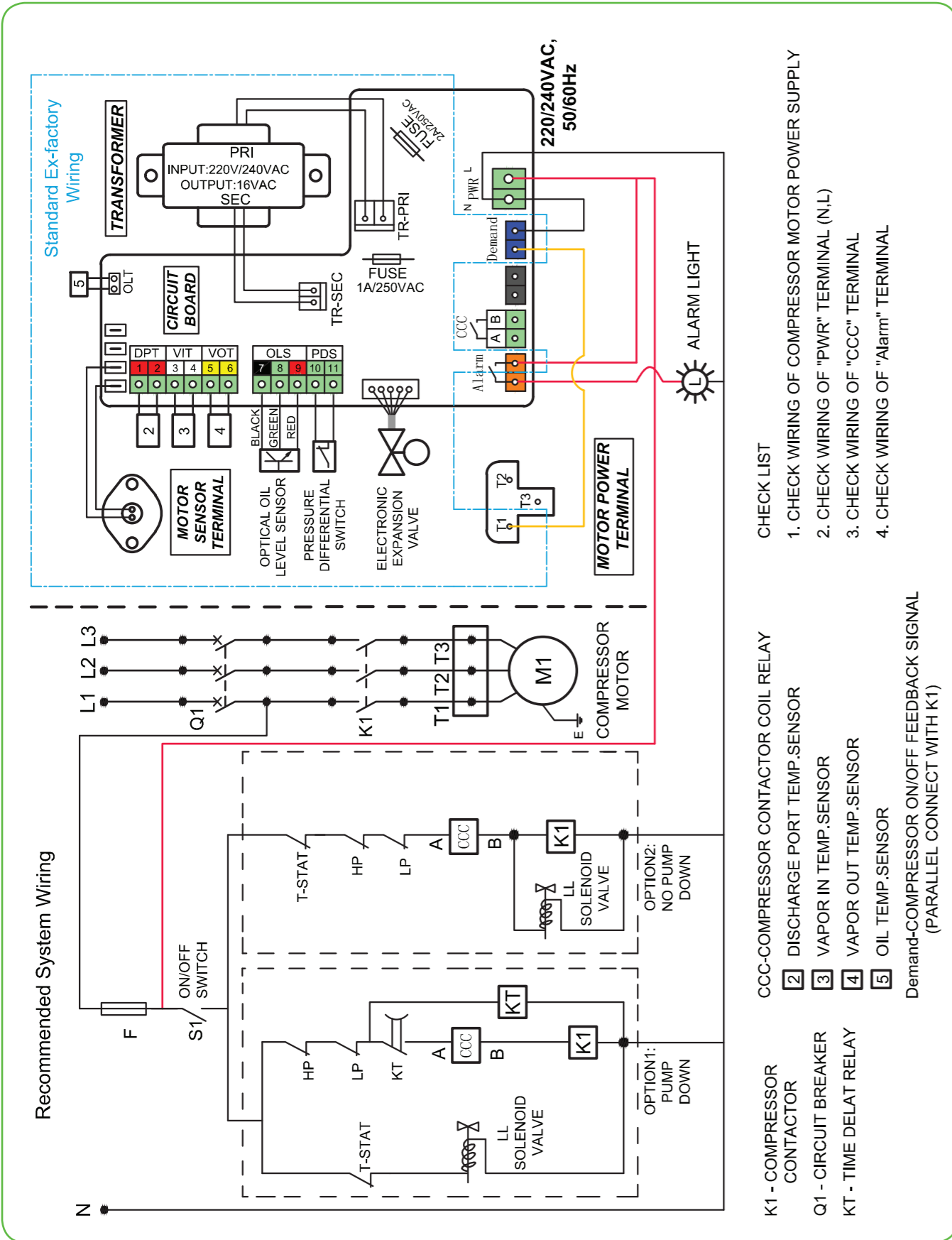

Figure 10. Wiring Diagram

# Wiring Instruction

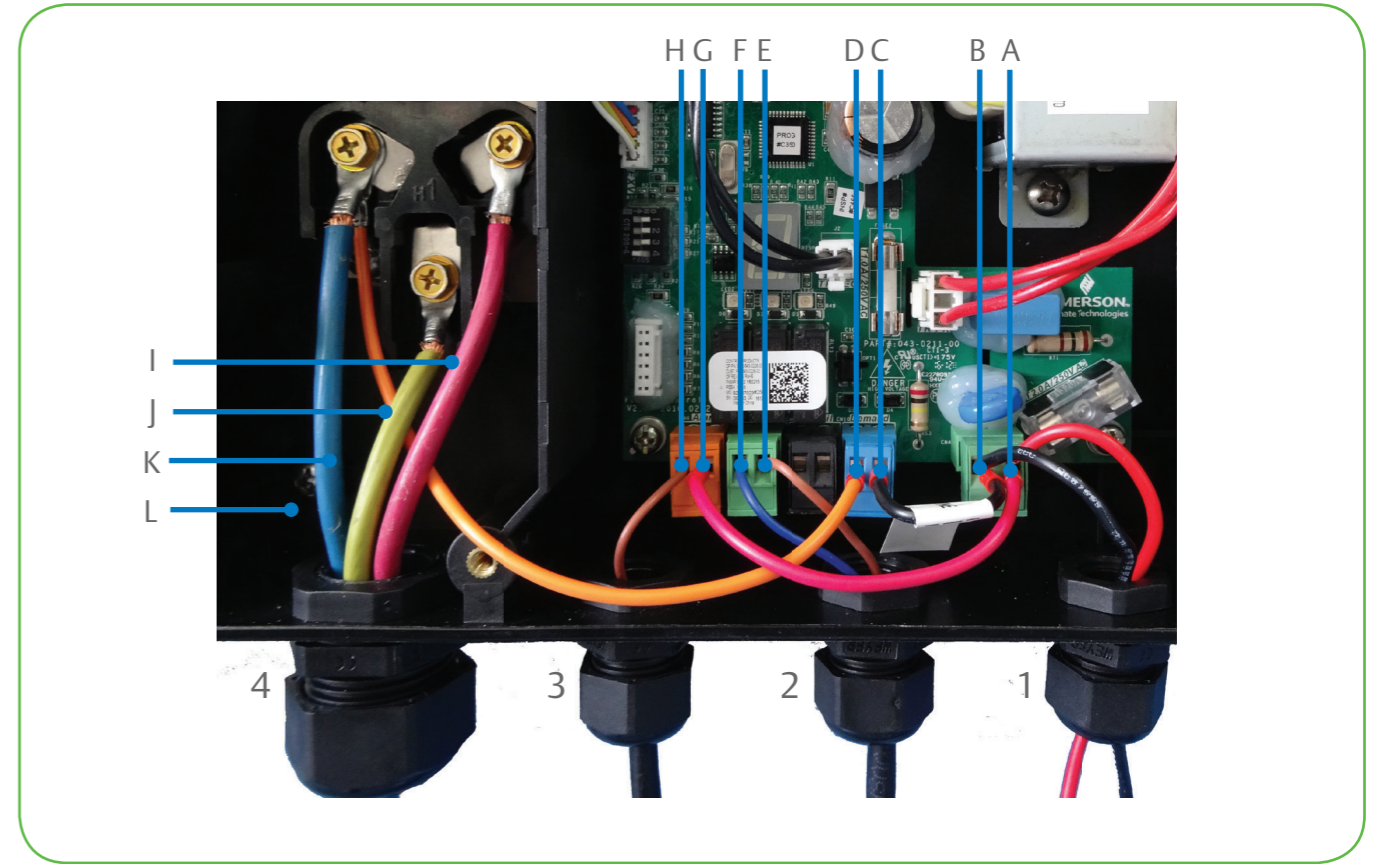

Figure 11. CoreSense™ Wiring and Joints

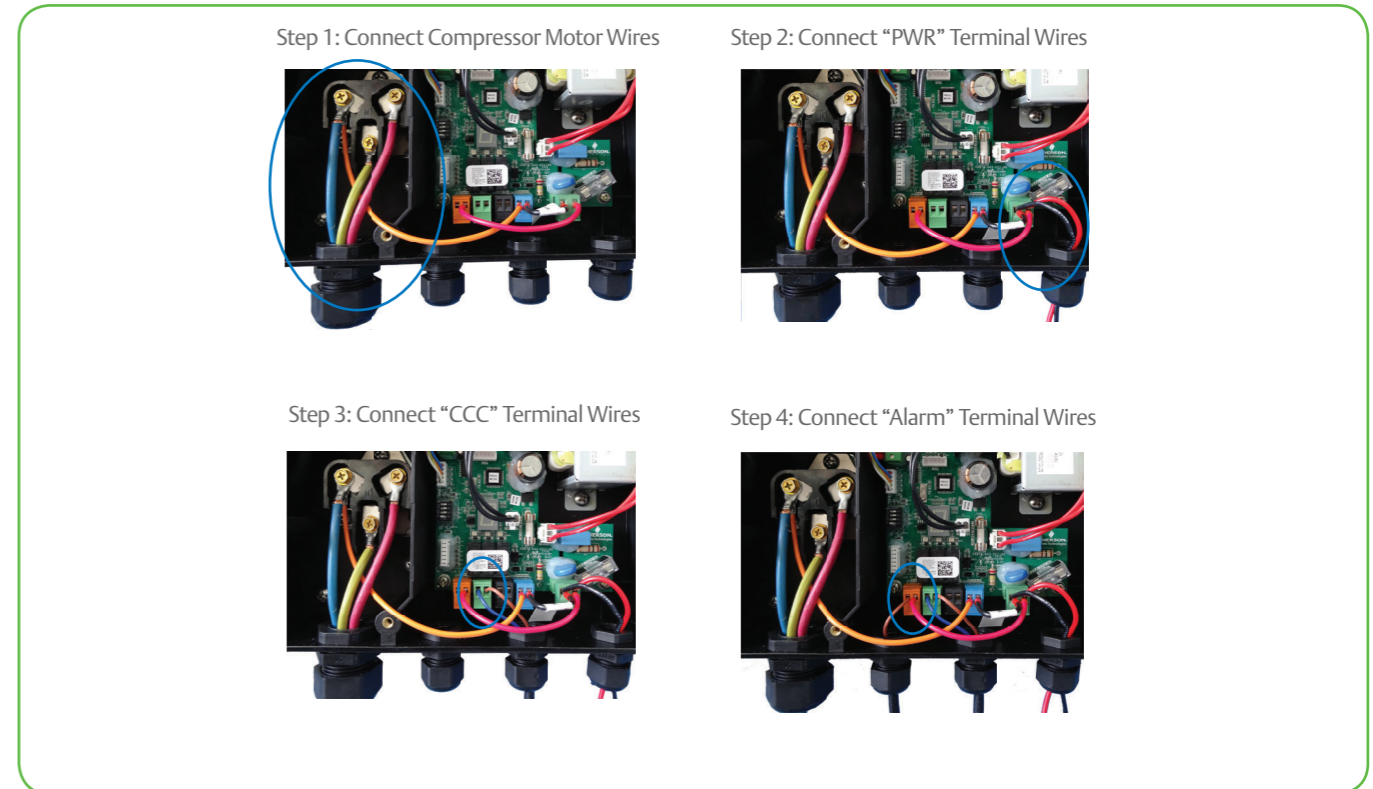

Figure 12. CoreSense™ Recommended Wiring Sequence

- CHECK LIST**
1. CHECK WIRING OF COMPRESSOR MOTOR POWER SUPPLY
  2. CHECK WIRING OF "PWR" TERMINAL (N,L)
  3. CHECK WIRING OF "CCC" TERMINAL
  4. CHECK WIRING OF "Alarm" TERMINAL

- CCC-COMPRESSOR CONTACTOR COIL RELAY**
- 2 DISCHARGE PORT TEMP.SENSOR
  - 3 VAPOR IN TEMP.SENSOR
  - 4 VAPOR OUT TEMP.SENSOR
  - 5 OIL TEMP.SENSOR
- Demand-COMPRESSOR ON/OFF FEEDBACK SIGNAL (PARALLEL CONNECT WITH K1)**



**Table 1: Glands and Wires**

Gland (Waterproof) Number	Gland 1	Gland 2	Gland 3	Gland 4
Gland Description	For "PWR" and "Demand" Connector's Wires	For "CCC" Connector's Wires	For "Alarm" Connector's Wires	For Compressor Motor Power Supply Wires
	One jacket line with two wires goes through the joint	One jacket line with two wires goes through the joint	One jacket line with two wires goes through the joint	One jacket (PVC) line with four wires goes through the joint
Wire Function	A(Red) and B(Black): Controller Power Supply Input(220-240VAC 50/60Hz)	E(Brown) and F(Blue): Compressor Diagnostic/ Protection Contact Output	H(Brown): Output For Alarm Devices	I, J, K: Compressor Motor Power Supply L: Earth Wire
	Wires A and B: "PWR" (Green) connectors	Wires E and F: "CCC" (Green) connectors	Wire H: "Alarm" (Orange) connectors	N/A
Gland Internal Diameter Range	5-10 mm	5-10 mm	5-10 mm	18-25mm
Jacket Line Requirement	Internal wire size: 18-20 AWG			Internal wire size: 8 AWG or above (4 wires in total)
	Recommended wire size: 18 AWG			
	Rated voltage: 300V/500V			Rated voltage: 600V/1000V



**Warning**

Reverse rotation and lack of pumping have the same symptoms: the discharge pressure does not rise and the suction pressure does not fall. If the control module senses that the differential pressure switch has not closed after a short time delay, the compressor will stop, an error message will be displayed on the control board, and a timer will be started. Three more attempts will be made to start and if differential pressure is not established, the compressor will be locked out. The alarm contact will close and can be used by the installer to turn on a light, sound a bell, etc. The alarm contact is voltage-free allowing maximum flexibility with regard to the type of alarm device that can be connected. The alarm relay contact is rated at 250 VAC 1A and 30 VDC 1A.



**Warning**

High discharge temperatures often occur when the system is short of refrigerant: suction temperature rises, bubbles form in the liquid line and there is insufficient liquid to feed the injection EXV properly. The control module will stop the compressor, display a fault code and close the alarm relay. After a time delay, the compressor

will restart. High discharge temperature alarms indicate a serious system problem, and corrective action must be taken to avoid long term compressor damage and possible product loss.



**Warning**

Oil stored in compressor high side oil tank keeps same pressure and temperature as discharge gas. When oil flows from oil tank to bearing, it goes through the heat exchanger in a separate passage for cooling. High oil temperature could cause to lubricating deterioration as well as bearing failure. If the oil temperature goes to its upper limitation, the control module will display an alarm code. If oil temperature continues to increase up to a setting point, compressor will be tripped, and could restart after time delay.



**Warning**

Oil level is monitored by an optical sensor in the high side oil sump. If the level falls to the minimum allowable, a timer will start and the compressor will be stopped if sufficient oil has not returned to the sump in one minute.

Two restarts will be attempted after short delays, and if the oil level does not recover, the compressor will be stopped and locked out. An alarm message will be displayed and the alarm relay will close.



**Warning**

Motor overheat may occur when the suction gas temperature is abnormally high, mass flow is low and discharge pressure is also high. Four thermistors are embedded in the windings and monitored by the control module. If the module senses that the winding temperature is high, it will stop the compressor and start a timer. A restart will be attempted when the windings have cooled and the timer has timed out. The compressor will not be locked out, but the cause of overheat must be investigated to prevent long term compressor damage. Motor overheat can be caused by a mechanical problem, which, if not rectified quickly, could cause complete compressor failure and system contamination. Common mechanical problems that lead to motor trips include worn bearings or worn scroll sets as a result of overheating.



**Caution**

Oil may not be visible when compressor is stopped. Run compressor until conditions are stable. Oil level should be between 1/4 and 3/4 sight glass.

**Checking Thermistors and Sensors**

Table 2 provides resistance values of the thermistors at several useful temperatures.



**Caution**

Use a voltage no higher than 3 VDC when testing.

An ice bath can be used at 0°C and boiling water can be used at 100°C.

**Table 2. Thermistors**

Location	Temperature		
	0°C	25°C	100°C
Discharge	326 K Ohm	100 K Ohm	7 K Ohm
Oil	326 K Ohm	100 K Ohm	7 K Ohm
Vapor In	28 K Ohm	10 K Ohm	950 Ohm
Vapor Out	28 K Ohm	10 K Ohm	950 Ohm

For the motor thermistor chain, the trip resistance is > 4.5 K Ohms and the reset resistance is < 2.75 K Ohms. Resistance at room temperature should be < 500 Ohms. If the oil level switch is not functioning correctly, the optical part can be easily changed without breaking into the system. Malfunction is also possible if the lens is coated by system contaminants. The lens will need to be removed and cleaned to restore correct operation.

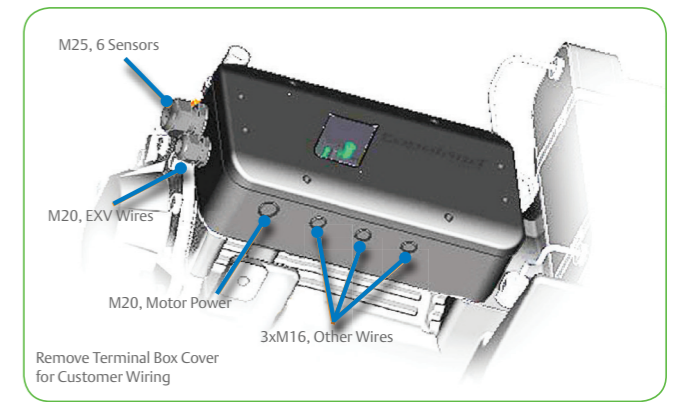

Figure 13. Terminal Box Location For Wiring

**Crankcase Heaters**

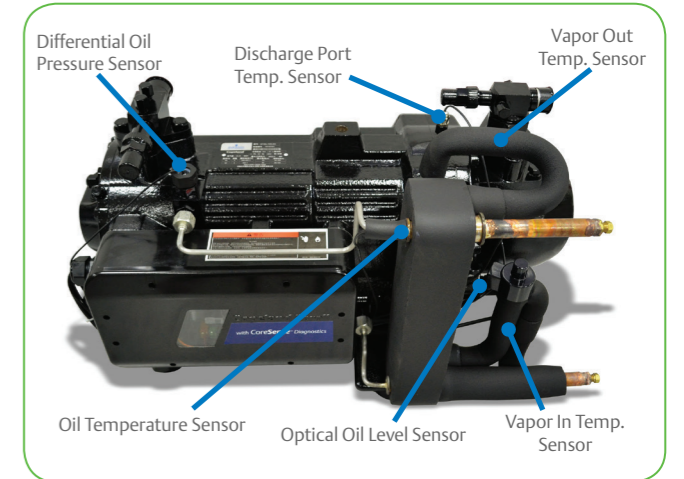

Figure 14. Sensor Location

Crankcase heaters are very effective in keeping liquid out of the compressor and are recommended for all installations. The heater should be on when the compressor is stopped.



**Caution**

At the time of initial startup, or after any extended period without power, the heater should be energized 12 hours before starting the compressor. Long off periods are common in cold stores holding seasonal products, so it is particularly important to turn on power to the unit 12 hours before restarting after a long idle period. A 220 V 60 W heater is supplied as standard equipment.

**Startup and Operation**

**Leak / Pressure Testing**

The compressor has been pressure tested in the factory. It is not necessary for the system manufacturer or installer to pressure test or leak-test the compressor again although the compressor will normally be exposed to the pressure used as part of system testing. Consider personal safety requirements and refer to nameplate test pressures prior to testing.



### Warning

The maximum pressure for leak testing should be no higher than 22.5 bar(g).

Use only dry nitrogen or dry air for system pressure testing. DO NOT USE other industrial gases.

If using dry air do not include the compressor in the pressure test – isolate it first. Never add refrigerant to the test gas (as leak indicator).

## System Evacuation and Dehydration

Before the installation is put into operation, remove the holding charge then evacuate with a vacuum pump. Proper evacuation reduces residual moisture to 50 ppm. The installation of adequately sized access valves at the furthest point from the compressor in the suction and liquid lines is advisable. To achieve undisturbed operation, the compressor valves are closed and the system is evacuated down to 0.3 mbar / 0.225 Torr. Pressure must be measured using a vacuum pressure (Torr) gauge on the access valves and not on the vacuum pump; this serves to avoid incorrect measurements resulting from the pressure gradient along the connecting lines to the pump. Then the compressor must be evacuated. Due to the factory holding charge of dry air, the compressor is under pressure (about 1-2.5 bar), this is to indicate the compressor does not leak.

## Preliminary Check

Discuss installation details with the installer. If possible, obtain drawings, wiring diagrams, etc. It is ideal to use a checklist but always check the following:

- Visual check of the electrics, wiring, fuses etc.
- Visual check of the plant for leaks, loose fittings such as TXV bulbs etc.
- Compressor oil level
- Calibration of HP and LP switches and any pressure actuated valves
- Check setting and operation of all safety features and protection devices
- All valves in the correct running position
- Pressure and compound gauges fitted
- Correctly charged with refrigerant
- Compressor electrical isolator location & position



### Warning

Never install a system in the field and leave it unattended when it has no charge, a holding charge, or with the service valves closed without securely electrically locking out the system. This will prevent unauthorized personnel from accidentally operating the system and potentially ruining the compressor by operating with no refrigerant flow.



### Warning

Do not start the compressor while the system is in a vacuum.

## Refrigerant Charging

PC Board should be powered to close EXV before charging. The system should be liquid-charged through the liquid-receiver shut-off valve or through a valve in the liquid line. The use of a filter drier in the charging line is highly recommended. Because scrolls have discharge check valves, systems should be liquid-charged on both the high and low sides simultaneously to ensure that a positive refrigerant pressure is present in the compressor before it runs.

Charging quantity can be determined by referring to system discharge and suction pressures. Another very useful parameter is the liquid line temperature which has been listed in the Fusion Catalogue. At a measured condensing temperature and an evaporating temperature, the liquid line temperature should be around Emerson's recommendation value within  $\pm 5K$  tolerance.



### Warning

The majority of the charge should be placed in the high side of the system to prevent bearing washout during first-time start on the assembly line or on site.

Do not operate with a restricted suction. Do not operate with the low-pressure cut-out bridged. Do not operate compressor without enough system charge to maintain at least 0.3 bar suction pressure. Allowing pressure to drop below 0.3 bar for more than a few seconds may overheat scrolls and cause early drive bearing damage. If the suction pressure is low on startup, and top up of the refrigerant charge is required, it is preferable to bleed liquid slowly into the suction line of a running compressor than to risk overheating by vapour charging.

The system should be liquid-charged through the liquid-receiver shut-off valve or through a valve in the liquid line. The use of a filter drier in the charging line is highly recommended. The majority of the charge should be placed in the high side of the system to prevent bearing washout during first-time start on the assembly line.

## Initial Startup



### Warning

It is important to ensure that new compressors are not subjected to liquid abuse. Turn the crankcase heater on 12 hours before starting the compressor..

# Maintenance

## Refrigerant Exchange

Qualified refrigerants and oils were indicated on page 8. It is not necessary to replace the refrigerant with a new one unless contamination due to an error such as topping up the system with an incorrect refrigerant is suspected. To verify correct refrigerant composition, a sample can be taken for chemical analysis. A check can be made during shut down by comparing the refrigerant temperature and pressure using precision measurements at a location in the system where liquid and vapor phases are present and when the temperatures have been stable.

In the event that the refrigerant needs replacing, the charge should be recovered using a suitable recovery machine.

When R22 in a system with mineral oil is to be replaced with R407C or R404A, the oil must also be changed. Please refer to Technical Information "Refrigerant changeover from HCFC to HFC Refrigerants".

## Replacing Compressor



### Warning

Rotalock valves should be re-torqued periodically to ensure that leak tightness is maintained. All gaskets and fittings should be inspected for signs of leaks and repaired if necessary. Electrical connections should be checked for tightness. All wires should be clamped securely and routed away from hot surfaces to prevent damage from vibration and heat.

Some minor repairs like sensor replacement can be done while the compressor is still under pressure. To replace components that are under pressure, shut down the compressor, wait 15 seconds, and turn off all power. Close the service valves, recover the refrigerant and change the faulty component. Evacuate the compressor only, open the service valves, and recharge the same quantity of refrigerant that was recovered.



### Warning

Change the accumulator after replacing a compressor with a burned out motor. The accumulator oil return orifice or screen may be plugged with debris or may become plugged. This will result in starvation of oil to the new compressor and a second failure.

In the case of a motor burnout, the majority of contaminated oil will be removed with the compressor. The rest of the oil is cleaned through the use of suction and liquid line filter

driers. A 100% activated alumina suction line filter drier is recommended but must be removed after 72 hours. It is highly recommended that the suction accumulator be replaced if the system contains one. This is because the accumulator oil-return orifice or screen may be plugged with debris or may become plugged shortly after a compressor failure. This will result in starvation of oil to the replacement compressor and a second failure. When a single compressor or tandem is exchanged in the field, it is possible that a major portion of the oil may still be in the system. While this may not affect the reliability of the replacement compressor, the extra oil will add to rotor drag and increase power usage.

## Lubrication and Oil Removal

Do not mix up ester oils with mineral oil and/or alkyl benzene when used with chlorine-free (HFC) refrigerants. The compressor is supplied with an initial oil charge. The standard oil charge for use with refrigerants R404A is a polyolester (POE) lubricant Emkarate RL 32 3MAF. In the field, the oil level could be topped up with Mobil EAL Arctic 22 CC if 3MAF is not available. The standard mineral oil for R22 is Karamay 32BYMO. Therefore it is recommended that a properly sized filter drier is installed in all POE systems. This will maintain the moisture level in the oil to less than 50 ppm.



### Warning

If the moisture content of the oil in a refrigeration system reaches unacceptably high levels, corrosion and copper plating may occur. The system should be evacuated down to 0.3 mbar or lower. If there is uncertainty as to the moisture content in the system, an oil sample should be taken and tested for moisture. Sight glass/moisture indicators currently available can be used with the HFC refrigerants and lubricants; however, the moisture indicator will just show the moisture content of the refrigerant. The actual moisture level of POE would be higher than what the sight glass indicates.

## Oil Additives

Although Emerson Climate Technologies cannot comment on any specific product, from our own testing and past experience, we do not recommend the use of any additives to reduce compressor bearing losses or for any other purpose. Furthermore, the long term chemical stability of any additive in the presence of refrigerant, low and high temperatures, and materials commonly found in refrigeration systems is complex and difficult to evaluate without rigorously controlled chemical laboratory testing.

The use of additives without adequate testing may result in malfunction or premature failure of components in the system and, in specific cases, in voiding the warranty on the component.

## Unbrazing System Components



### Warning

Oil-refrigerant mixtures are highly flammable. Remove all refrigerant before opening the system. Avoid working with an unshielded flame in a refrigerant charged system. Before opening up a system, it is important to remove all refrigerant from both the high and low sides of the system. If the refrigerant charge is removed from a scroll-equipped unit, it is possible for the scrolls to seal, preventing pressure equalization through the compressor. This may leave the low side shell and suction line tubing pressurized. If a brazing torch is applied to the low side while

the low side shell and suction line contain pressure, the pressurized refrigerant and oil mixture could ignite when it escapes and comes in contact with the brazing flame. To prevent this occurrence, it is important to check both the high and low sides with manifold gauges before unbrazing. Instructions should be provided in appropriate product literature and assembly (line repair) areas. If compressor removal is required, the compressor should be cut out of system instead of unbrazing.

## Dismantling and Disposal

Removing oil and refrigerant

- Do not disperse in the environment.
- Use the correct equipment and method of removal.
- Dispose of oil and refrigerant properly.
- Dispose of compressor properly.



## Appendix

### Fault Diagnostic Code

Code	Description	Status	Compressor Action
0	ON	Normal	Normal compressor operation
0	FLASH	Normal	Normal compressor standby
0	FLASH	Fault	EXV will not work so compressor must stop
1	FLASH	Fault	Compressor shutdown and automatic reset after 10 min delay
2	FLASH	Fault	Compressor shutdown and automatic reset after 10 min delay
3	FLASH	Fault	Compressor shutdown and automatic reset after 5 min delay
4	FLASH	Fault	Compressor shutdown and automatic reset after 3 min delay
5	FLASH	Fault	Compressor shutdown and automatic reset after 10 min delay
6	FLASH	Fault	Compressor shutdown and automatic reset after 5 min delay under open/short circuit failure / 10 min delay under other failure mode
7	FLASH	Fault	Compressor don't shutdown
8	FLASH	Fault	Compressor don't shutdown
9	FLASH	Fault	Compressor don't shutdown under oil temperature sensor failure, but oil temperature protection function fail . Show alarming under high oil temperature, compressor shutdown if oil temperature continue to increase and automatic reset after 10 min delay
3 and F	Alternate display	Normal	Show alarming and continue running. Give precaution
5 to 9	Number FLASH	Fault	When power on 1st time, if any sensor among motor thermistor, discharge temperature sensor, PHE inlet temperature sensor, PHE outlet temperature sensor and oil temperature sensor is wrong, immediately locked
3	Number FLASH/' on	Fault	The 4th low oil level in 1 hour, compressor shutdown and locked, manual reset (cut off power)
4	Number FLASH/' on	Fault	The 4th low differential pressure in 1 hour, compressor shutdown and locked

- Fault diagnostic code is visible through a transparent window on the cover
- The code and description can be found inside of the cover

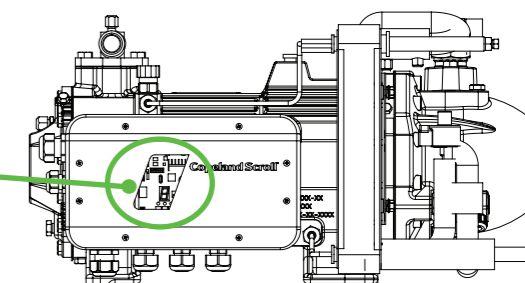

## Tool List

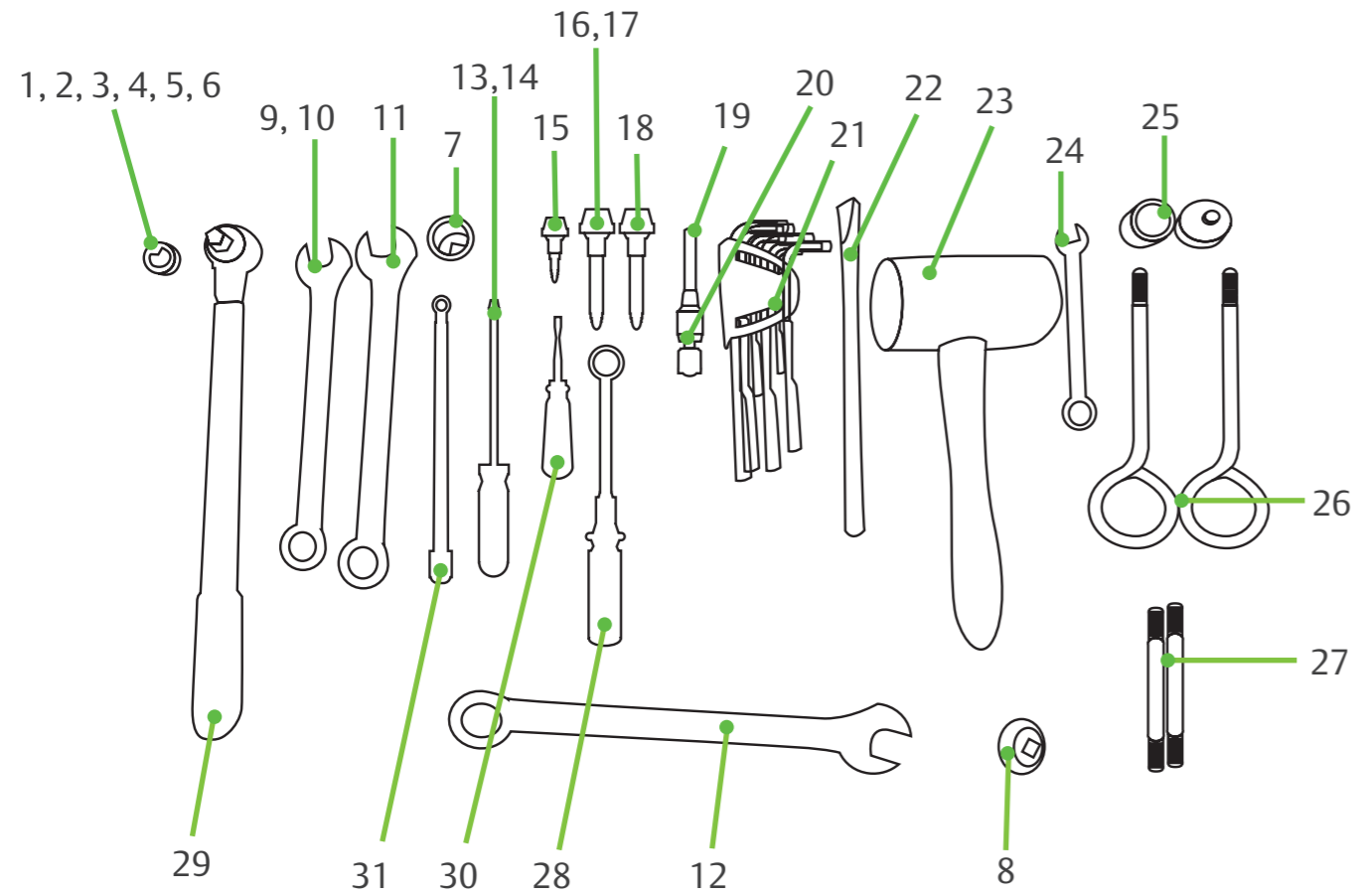

Components	Item No. on Page 11 (Table)	Tool No.	Tool Description	Tool Specification	Torque Value (N.m)
Pressure Differential Sensor (Mechanical Part, Lower Cover)	1	8, 29	Metric Hexagon Socket, Torque Wrench	1"	100–110
Three-phase Terminal Plate	–	1, 28		10 mm	12–15
PTC Thermistor	–	1, 28		10 mm	12–15
Oil Charge Fitting Plug (Lower Cover)	2	2, 29		18 mm	32–42
Oil Drain Oil Fitting Plug (Lower Cover)	4	2, 29		18 mm	32–42
Lower Cover Bolts	–	3, 29		16 mm	57–68
Check Valve Bolts	–	2, 29		18 mm	90–100
Suction Valve Bolts	–	2, 29		18 mm	90–100
Oil Drain Oil Fitting Plug (Oil screen, Top Cap)	19	4, 29		26 mm	130–140
Oil Sight Glass Bolts	20	5		10 mm	7.5–10
Oil Charge Fitting Plug (Top Cap)	24	2, 29	18 mm	32–42	

Components	Item No. on Page 11 (Table)	Tool No.	Tool Description	Tool Specification	Torque Value (N.m)
Oil Level Sensor	18	–	Opening Wrench	29 mm	130–140
Discharge Valve (Rotate)	25	–		50 mm	54–60
Rotalock Nut for Oil Out Tube	5	9		22 mm	25–30
Rotalock Nut for Oil In Tube	10	9		22 mm	25–30
Nuts of Tube-Oil Pulsation	–	9		22 mm	25–30
EVI Rotalock Nut	15	11		24 mm	40–50
Pressure Differential Sensor (Mechanical Part, Lower Cover)	1	12		1"	100–110
Terminal Box Cover Screws	–	13	Cross Screwdriver	H3/6"	1–2
Screw - CoreSense™ Connect to Terminal Box	–	14		H3/6"	1–2
CoreSense Terminal Connectors	–	30	Voltage Tester	M3	N/A
Transformer Bolts	–	15, 28	Metric Internal Hexagon Socket, Torque Wrench	3 mm	3.40–5.10
Thrust Plate Bolts	–	16, 28		4 mm	5.65–7.75
Oil Separator Bolts	–	17, 28		4 mm	5–6
Bolt - Terminal Box Connect to Body	–	18, 28		5 mm	3.40–5.10
Top Cap Bolts	–	19, 29		10 mm	80–90
Top Cap and Lower Cover	–	22	Flat Chisel	–	N/A
Top Cap and Lower Cover	–	23	Rubber Hammer	–	N/A
Top Cap	–	27	Special Bolts	M12	N/A
HVE Holder	–	25, 28	Special Socket, Torque Wrench	–	12–15
Scroll Set	–	26	Torque Wrench	M10	N/A
Screw-Upper Counterweight	–	24	Opening Wrench	13 mm	12–15
For Torque Wrench	–	20	Connecting Piece	1/2 to 3/8	N/A
For Socket	–	28	Torque Wrench	–	5–25
For Socket	–	29		–	30–150
For Torque Wrench	–	31	Extension Bars	–	N/A
—	–	21	Offset Socket Screw Key Set	1.5 to 10 mm	For Teardown Only

# Contact lists

## Emerson Commercial & Residential Solutions

### Asia Pacific Headquarters

Emerson Climate Technologies  
Suite No. 2503-8, 25/F,  
Exchange Tower, 33 Wang Chiu Road,  
Kowloon Bay, Kowloon, Hong Kong  
Tel: (852) 2866 3108  
Fax: (852) 2520 6227

### Australia

Emerson Climate Technologies  
Australia Pty Ltd  
356 Chisholm Road  
Auburn NSW 2144, Australia  
Tel: (612) 9795 2800  
Fax: (612) 9738 1699

### China - Beijing

Emerson Climate Technologies  
(Suzhou) Co. Ltd  
Beijing Sales Office  
Room 1017 JianWei Building,  
66 Nan Lishi Road, XiCheng District,  
Beijing, PRC  
Tel: (8610) 5763 0488  
Fax: (8610) 5763 0499

### China - Guangzhou

Emerson Climate Technologies  
(Suzhou) Co. Ltd  
Guangzhou Sales Office  
508-509 R&F Yinglong Plaza,  
No. 76 Huangpu Road West,  
Guangzhou, PRC  
Tel: (8620) 2886 7668  
Fax: (8620) 2886 7622

### China - Shanghai

Emerson Climate Technologies  
(Suzhou) Co. Ltd  
Shanghai Sales Office  
7F, Emerson Building, 1582 Gumei  
Rd, Shanghai, PRC  
Tel: (8621) 3338 7333

### India - Mumbai

Emerson Climate Technologies (India) Ltd  
Delphi B-Wing, 601-602, 6th Floor  
Central Avenue, Hiranandani Business Park,  
Powai, Mumbai 400076  
Tel: (9122) 6786 0793  
Fax: (9122) 6662 0500

### India - Pune

Emerson Climate Technologies (India) Ltd  
Plot No. 23, Rajiv Gandhi Infotech Park,  
Phase - II, Hinjewadi,  
Pune 411 057, Maharashtra, India  
Tel: (9120) 4200 2000  
Fax: (9120) 4200 2099

### Indonesia

PT Emerson Indonesia  
BSD Taman Tekno 8  
Jl. Tekno Widya Blok H10 No 2 & 3  
Tangerang Selatan 15314  
Indonesia  
Tel: (6221) 2966 6242  
Fax: (6221) 2966 6245

### Japan

Emerson Japan Ltd  
Shin-yokohama Tosho Building  
No. 3-9-5 Shin-Yokohama, Kohoku-ku  
Yokohama 222-0033 Japan  
Tel: (8145) 475 6371  
Fax: (8145) 475 3565

### Malaysia

Emerson Electric (Malaysia) Sdn. Bhd.  
Level M2, Blk A, Menara PKNS-PJ  
Jalan Yong Shook Lin  
46050 Petaling Jaya, Selangor, Malaysia  
Tel: (603) 7949 9222  
Fax: (603) 7949 9333

### Middle East & Africa

Emerson Climate Technologies  
PO Box 26382  
Jebel Ali Free Zone – South  
Dubai, UAE  
Tel: (9714) 811 8100  
Fax: (9714) 886 5465

### Philippines

Emerson Climate Technologies  
10/F SM Cyber West Avenue, EDSA cor. West  
Avenue, Barangay Bungad, Diliman, Quezon  
City 1105 Philippines  
Tel: (632) 689 7200

### Saudi Arabia

Emerson Arabia Inc.  
P.O Box 34332 – 3620 Building 7874  
Unit 1, 67th street 2nd Industrial City  
Dammam, Saudi Arabia  
Toll Free: 8008443426  
Tel: + 966 3 8147560  
Fax: + 966 3 8147570

### South Korea

Emerson Electric Korea Ltd.  
3F POBA Gangnam Tower  
343, Hakdong-ro, Gangnam-gu,  
Seoul 135-820, Republic of Korea  
Tel: (822) 3483 1500  
Fax: (822) 592 7883

### Taiwan

Emerson Electric (Taiwan) Co. Ltd  
3F No. 122 Lane 235,  
Pao Chiau Rd., XinDian Dist.,  
New Taipei City 23145, Taiwan ( R.O.C.)  
Tel: (8862) 8912 1360  
Fax: (8862) 8912 1890

### Thailand - Bangkok

Emerson Electric (Thailand) Ltd  
34th Floor, Interlink Tower,  
1858/133, Bangna Trad,  
Bangkok 10260, Thailand  
Tel: (662) 716 4700  
Fax: (662) 751 4241

### United Arab Emirates

Emerson Climate Technologies FZE  
Jebel Ali Free Zone  
PO Box 26382  
Dubai UAE  
Toll Free: 8004413428  
Tel: + 971 4 8118100  
Fax: + 971 4 8865465

### Vietnam

Emerson Commercial & Residential Solutions  
Level 6, Melinh Point Tower, 2 Ngo Due Ke,  
District 1, Ho Chi Minh City  
Vietnam  
Tel: (84) 908 009 189

## EmersonClimateAsia.com

Asia 02 B04 10 – R00 Issued 08/2016 – GSCAA032

Emerson, CoreSense Diagnostics and Copeland Scroll Fusion are trademarks of Emerson Electric Co. or one of its affiliated companies.  
©2013 Emerson Climate Technologies, Inc. All rights reserved.

Scan With Your  
Smartphone For  
More Information



052-6905-09